

**TECHNICAL MANUAL**

**OPERATOR'S MANUAL  
FOR**

This copy is a reprint which includes current pages from Change 1.

**EQUIPMENT DESCRIPTION 1-5**

**OPERATING INSTRUCTIONS 2-1**

**CONTROLS AND INDICATORS 2-1**

**PREVENTIVE MAINTENANCE CHECKS AND SERVICES (PMCS) 2-207**

**LANDING**

**CRAFT, UTILITY  
(LCU 2000 CLASS)  
NSN 1905-01-154-1191**

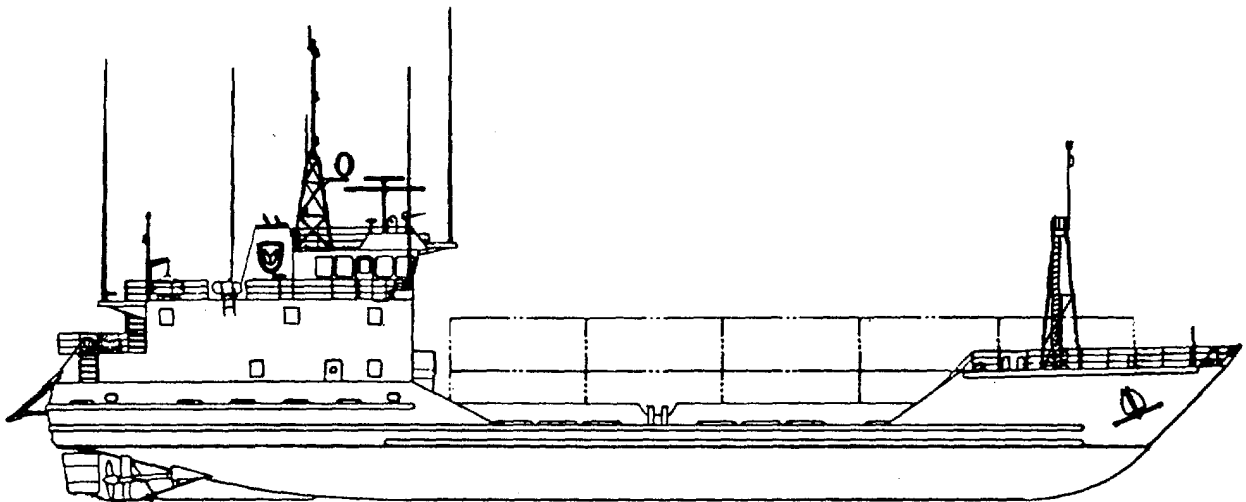

Approved for public release. Distribution is unlimited.



Insert latest changed pages. Destroy superseded data.

**LIST OF EFFECTIVE PAGES**

Note: The portion of text affected by the changes is indicated by a vertical line in the outer margins of the page. Changes to illustrations are indicated by miniature pointing hands. Changes to wiring diagrams are indicated by shaded areas.

Date of issue for original and changed pages are:

Original	0	17 January 1989
Change	1	6 April 1990
Change	2	3 April 1992
Change	3	9 November 1992
Change	4	29 October 1993
Change	5	14 March 1994
Change	6	28 February 1995
Change	7	1 July 1996
Change	8	10 October 1996
Change	9	21 February 1997
Change	10	15 March 2002

<b>Page No.</b>	<b>Change No.*</b>	<b>Page No.</b>	<b>Change No.*</b>	<b>Page No.</b>	<b>Change No.*</b>
Cover.....	0	1-54 .....	10	2-108 and 2-109.....	2
A and B.....	10	1-55 through 1-59 .....	0	2-110 and 2-111.....	0
a and b .....	2	1-60 .....	10	2-112 .....	2
i .....	10	1-61 through 1-69 .....	0	2-113 .....	0
ii .....	9	1-70 .....	2	2-114 .....	2
iii through vi .....	0	1-71/(1-72 blank).....	0	2-114.1 through 2-120 .....	0
1-1 .....	0	1-73 .....	3	2-121 .....	10
1-2 .....	10	1-74 .....	0	2-122 through 2-144 .....	0
1-3 through 1-8.....	6	1-74.1/(1.74.2 blank).....	3	2-145 through 2-148 .....	10
1-9 .....	0	1-75 .....	0	2-149 .....	0
1-10 and 1-11 .....	1	1-76 .....	10	2-150 .....	1
1-12 through 1-15.....	0	1-77 through 1-101 .....	0	2-151 through 2-160 .....	0
1-16 .....	10	1-102 .....	10	2-161 .....	1
1-17 .....	0	1-103 .....	0	2-162 through 2-206 .....	0
1-18 .....	10	1-104 .....	0	2-207 .....	6
1-19 .....	0	1-104.1 and 1-104.2.....	10	2-208 through 2-213 .....	0
1-20 .....	10	1-105 through 1-107 .....	0	2-214 .....	4
1-21 through 1-26.....	0	1-108 .....	3	2-215 through 2-225 .....	0
1-27 through 1-29.....	6	1-109 through 1-153 .....	0	2-226 through 2-226.2 .....	1
1-30 through 1-35.....	0	1-154 .....	10	2-227 through 2-230 .....	0
1-36 .....	2	1-155 through 1-181 .....	0	2-230.1/(2-230.2 blank).....	0
1-37 .....	0	1-182 through 1-184 .....	10	2-231 and 2-232.....	0
1-38 .....	2	2-1 through 2-10 .....	0	2-233 .....	4
1-39 .....	10	2-11 through 2-12.2 .....	2	2-234 through 2-241 .....	0
1-40 through 1-42.....	0	2-13 .....	0	2-242 .....	10
1-43 .....	2	2-14 and 2-14.1.....	2	2-243 through 2-246 .....	0
1-44 and 1-45.....	0	2-14.2 through 2-88 .....	0	2-247 .....	10
1-46 .....	10	2-89 .....	2	2-248 through 2-281 .....	0
1-47 .....	0	2-90 and 2-91.....	0	2-282 .....	10
1-48 .....	10	2-92 .....	2	2-283 through 2-299 .....	0
1-49 through 1-53.....	0	2-93 through 2-107 .....	0	2-300 .....	2

Page No.	Change No.*	Page No.	Change No.*	Page No.	Change No.*
2-301	1	2-530	2	B-41	2
2-302 through 2-307	0	2-531 through 2-534	0	B-42 through B-46	4
2-308	1	2-535	1	B-47 through B-55	0
2-309 through 2-3250		2-536 through 2-546	0	B-56	6
2-326	2	2-547 and 2-548	2	B-57	2
2-327	0	2-549 through 2-562	0	B-58 through B-60	0
2-328 and 2-329	2	2-563	2	B-61 and B-62	3
2-330 through 2-351	0	2-564 through 2-568	0	B-63	0
2-352 thru 2-352.2	1	2-569	2	B-64	7
2-353 through 2-359	0	2-570 through 2-591	0	B-65 and B-66	0
2-360	2	2-592	2	B-67	2
2-361 through 2-364	0	2-593 through 2-602	0	B-68 through B-70	0
2-365/(2-366 blank)	2	2-603 and 2-604	2	B-71 through B-76	4
2-367 and 2-368	0	2-605 through 2-611	0	C-1 and C-2	0
2-368.1 thru 2-368.4	2	2-612	2	D-1 through D-3	0
2-369 through 2-380	0	2-613	0	D-4 through D-8	2
2-381	2	2-614	1	D-9 and D-10	4
2-382 through 2-423	0	2-615 through 2-640	0	E-1/(E-2 blank)	0
2-424 through 2-433	2	2-641	10	F-1 through F-26	0
2-434 and 2-435	1	2-642 through 2-645	0	G-1 through G-102	8
2-436 and 2-437	0	2-646	1	Index 1 through Index-7	0
2-438	2	2-647 through 2-650.2	2	Index 8	10
2-439	0	2-651/(2-652 blank)	10	Index 9 through Index 11	0
2-440	2	2-653 through 2-665	0	Index 12 and Index 13	1
2-441 and 2-442	0	2-666	1	Index 14 through Index 17	0
2-443	10	2-667 and 2-668	0	Index 18	2
2-444 and 2-445	0	2-669	1	Index 19 through Index 22	0
2-446	10	2-670 through 2-685	0	Index 23/(Index 24 blank)	10
2-447 through 2-454	0	2-686	1		
2-455	2	2-687 through 2-705	0		
2-456 through 2-470	0	2-706 and 2-707	1		
2-471 and 2-472	1	2-708 through 2-718	0		
2-473	0	2-719 and 2-720	7		
2-474	2	2-721 through 2-746	10		
2-475 through 2-480	0	3-1/(3-2 blank)	0		
2-481 and 2-482	2	A-1 and A-2	10		
2-483	0	A-3/(A-4 blank)	6		
2-484	2	B-1 through B-7	6		
2-485	0	B-8 through B-17	9		
2-486	1	B-18 through B-20	0		
2-487	0	B-21	9		
2-488 and 2-489	1	B-22 and B-23	0		
2-490 through 2-496	0	B-24 and B-25	9		
2-497 and 2-498	2	B-26 through B-29	0		
2-499 through 2-505	0	B-30	9		
2-506	2	B-31 through B-34	0		
2-507 through 2-510	0	B-35 and B-36	9		
2-511	2	B-37	0		
2-512 through 2-517	0	B-38	9		
2-518 and 2-519	2	B-39	0		
2-520 through 2-529	0	B-40	9		

CHANGE  
NO. 10

HEADQUARTERS  
DEPARTMENT OF THE ARMY  
WASHINGTON, D.C., 15 MARCH 2002

**OPERATOR'S MANUAL  
FOR  
LANDING CRAFT UTILITY (LCU 2000 CLASS)  
NSN 1905-01-154-1191**

DISTRIBUTION STATEMENT A: Approved for public release; distribution is unlimited.

TM 55-1905-223-10, 17 January 1989, is changed as follows:

1. Remove and insert pages as indicated below. New or changed text material is indicated by a vertical bar in the margin. An illustration change is indicated by a miniature pointing hand.

Remove Pages	Insert Pages
----	A and B
i and ii	i and ii
1-1 and 1-2	1-1 and 1-2
1-15 thru 1-20	1-15 thru 1-20
1-39 and 1-40	1-39 and 1-40
1-45 thru 1-48	1-45 thru 1-48
1-53 and 1-54	1-53 and 1-54
1-59 and 1-60	1-59 and 1-60
1-75 and 1-76	1-75 and 1-76
1-101 and 1-102	1-101 and 1-102
----	1-104.1 and 1-104.2
1-153 and 1-154	1-153 and 1-154
1-181 and 1-182	1-181 thru 1-183/(1-184 blank)
2-121 and 2-122	2-121 and 2-122
2-145 thru 2-148	2-145 thru 2-148
2-241 and 2-242	2-241 and 2-242
2-247 and 2-248	2-247 and 2-248
2-281 and 2-282	2-281 and 2-282
2-443 thru 2-446	2-443 thru 2-446
2-641 and 2-642	2-641 and 2-642
2-651/(2-652 blank)	2-651/(2-652 blank)
----	2-721 thru 2-746
A-1 and A-2	A-1 and A-2
Index 7 and Index 8	Index 7 and Index 8
Index 23/(Index 24 blank)	Index 23/(Index 24 blank)
electronic 2028	electronic 2028
2028's	2028's

2. Retain this sheet in front of manual for reference purposes.

**By Order of the Secretary of the Army:**

ERIC K. SHINSEKI  
*General, United States Army*  
*Chief of Staff*

Official:

  
JOEL B. HUDSON  
*Administrative Assistant to the*  
*Secretary of the Army*  
0201508

DISTRIBUTION:

To be distributed in accordance with Initial Distribution Number (IDN) 254821, requirements for TM 55-1905-223-10.

CHANGE  
NO. 9

HEADQUARTERS  
DEPARTMENT OF THE ARMY  
WASHINGTON, D.C., 21 FEBRUARY 1997

**Operator's Manual**  
**for**  
**LANDING CRAFT UTILITY (LCU 2000 CLASS)**  
**NSN 1905-01-154-1191**

DISTRIBUTION STATEMENT A: Approved for public release; distribution is unlimited

TM 55-1905-223-10, 17 January 1989, is changed as follows:

1. Remove and insert pages as indicated below. New or changed text material is indicated by a vertical bar in the margin. An illustration change is indicated by a miniature pointing hand.

Remove pages	Insert pages
i and ii	i and ii
B-7 through B-18	B-7 through B-18
B-21 through B-26	B-21 through B-26
B-29 and B-30	B-29 and B-30
B-35 through B-40	B-35 through B-40

2. Retain this sheet in front of manual for reference purposes.

**By Order of the .secretary of the Army:**

DENNIS J. REIMER  
*General, United States Army*  
*Chief of Staff*

Official:

JOEL B. HUDSON  
*Administrative Assistant to the*  
*Secretary of the Army*  
03104

DISTRIBUTION:

To be distributed in accordance with DA Form 1 2-25-E, block no. 4821, requirements for TM 55-1905-223-10



CHANGE

NO. 8

HEADQUARTERS  
DEPARTMENT OF THE ARMY  
WASHINGTON, D.C., 10 October 1996

**Operator's Manual  
FOR  
LANDING CRAFT, UTILITY  
(LCU 2000 CLASS)  
NSN 1905-01-154-1191**

DISTRIBUTION STATEMENT A: Approved for public release; distribution is unlimited.

TM 55-1905-223-10, 17 January 1989, is changed as follows:

1. Remove and insert pages as indicated below. New or changed text material is indicated by a vertical bar in the margin. An illustration change is indicated by a miniature pointing hand.

Remove pages  
i and ii  
-----

Insert pages  
i and ii  
G-1 through G-101/(G-102 blank)

2. Retain this sheet in front of manual for reference purposes.

**By Order of the Secretary of the Army:**

DENNIS J. REIMER  
*General, United States Army  
Chief of Staff*

Official:

JOEL B. HUDSON  
*Administrative Assistant to the  
Secretary of the Army  
03038*

DISTRIBUTION:

To be distributed in accordance with DA Form 12-25-E, block no. 4821, requirements for TM 55-1905-223-10.

CHANGE  
NO.7

HEADQUARTERS  
DEPARTMENT OF THE ARMY  
WASHINGTON, D.C., 1 July 1996

OPERATOR'S MANUAL  
FOR

**LANDING CRAFT, UTILITY (LCU 2000 CLASS)**  
**NSN 1905-01-154-1191**

DISTRIBUTION STATEMENT A: Approved for public release; distribution is unlimited.

TM 55-1905-223-10, dated 17 January 1989, is changed as follows:

1. Remove and insert pages as indicated below. New or changed text material is indicated by a vertical bar in the margin. An illustration change is indicated by a miniature pointing hand.

Remove pages  
2-641 and 2-642  
2-719/(2-720 Blank)  
B-63 and B-64

Insert pages  
2-641 and 2-642  
2-719 and 2-720  
B-63 and B-64

2. Retain this sheet in front of manual for reference purposes.

**By Order of the Secretary of the Army:**

Official:

JOEL B. HUDSON  
*Administrative Assistant to the  
Secretary of the Army*  
01938

DENNIS J. REIMER  
*General, United States Army  
Chief of Staff*

**DISTRIBUTION:**

To be distributed in accordance with DA Form 12-25-E, block no. 4821, requirements for  
TM 55-1905-223-10.

CHANGE

NO. 6

HEADQUARTERS  
DEPARTMENT OF THE ARMY  
WASHINGTON, D.C., 28 February 1995

OPERATOR'S MANUAL  
FOR

**LANDING CRAFT, UTILITY (LCU 2000 CLASS)  
NSN 1905-01-154-1191**

DISTRIBUTION STATEMENT A: Approved for public release; Distribution is unlimited.

TM 55-1905-223-10, dated 17 January 1989, is changed as follows:

1. Remove and, insert pages as indicated below. New or changed text material is indicated by a vertical bar in the margin. An illustration change is indicated by a miniature pointing hand.

Remove pages	Insert pages
1-3/(1-4 blank)	1-3/(1-4 blank)
1-5 through 1-8	1-5 through 1-8
1-27 and 1-28	1-27 and 1-28
-----	1-28.1/(1-28.2 blank)
1-29 and 1-30	1-29 and 1-30
2-207 and 2-208	2-207 and 2-208
-----	2-230.1/(2-230.2 blank)
A-3/(A-4 blank)	A-3/(A-4 blank)
B-1 through B-6	B-1 through B-6
-----	B-6.1 and B-6.2
B-7 and B-8	B-7 and B-8
B-55 and B-56	B-55 and B-56

2. Retain this sheet in front of manual for reference purposes.

By Order of the Secretary of the Army:

Official:

GORDON R. SULLIVAN  
*General, United States Army*  
*Chief of Staff*

MILTON H. HAMILTON  
*Administrative Assistant to the*  
*Secretary of the Army*  
08049

DISTRIBUTION:

To be distributed in accordance with DA Form 12-25-E, block no. 4821, requirements for TM 55-1905-223-10.

CHANGE

NO. 5

HEADQUARTERS  
DEPARTMENT OF THE ARMY  
WASHINGTON, D.C., 14 March 1994

Operator's Manual  
for  
LANDING CRAFT, UTILITY  
(LCU 2000 CLASS)  
NSN 1905-01-154-1191

DISTRIBUTION STATEMENT A: Approved for public release; distribution is unlimited.

TM 55-1905-223-10, 17 January 1989, is changed as follows:

1. Remove and insert pages as indicated below. New or changed text material is indicated by a vertical bar in the margin. An illustration change is indicated by a miniature pointing hand.

Remove pages

i and ii  
B-9 and B-10

Insert pages

i and ii  
B-9 and B-10

2. Retain this sheet in front of manual for reference purposes.

By Order of the Secretary of the Army:

Official:

MILTON H. HAMILTON  
*Administrative Assistant to the  
Secretary of the Army*  
06408

GORDON R. SULLIVAN  
*General, United States Army  
Chief of Staff*

DISTRIBUTION:

To be distributed in accordance with DA Form 12-25-E, block no. 4821, requirements for  
TM 55-1905-223-10.

CHANGE

NO. 4

HEADQUARTERS  
DEPARTMENT OF THE ARMY  
WASHINGTON, D.C., 29 October 1993

Operator's Manual  
for  
LANDING CRAFT, UTILITY  
(LCU 2000 CLASS)  
NSN 1905-01-154-1191

DISTRIBUTION STATEMENT A: Approved for public release; distribution is unlimited

TM 55-1905-223-10, 17 January 1989, is changed as follows:

1. Remove and insert pages as indicated below. New or changed text material is indicated by a vertical bar in the margin. An illustration change is indicated by a miniature pointing hand.

Remove pages

1-5 and 1-6  
2-213 and 2-214  
2-233 and 2-234  
B-41 through B-46  
B-71 through B-74  
-----

Insert pages

1-5 and 1-6  
2-213 and 2-214  
2-233 and 2-234  
B-41 through B-46  
B-71 through B-75/(B-76 Blank)  
D-9 and D-10

2. Retain this sheet in front of manual for reference purposes.

By Order of the Secretary of the Army:

Official:

MILTON H. HAMILTON  
*Administrative Assistant to the  
Secretary of the Army*  
05696

GORDON R. SULLIVAN  
*General, United States Army  
Chief of Staff*

DISTRIBUTION:

To be distributed in accordance with DA Form 12-25-E, block no. 4821, requirements for  
TM 55-1905-223-10.

CHANGE

NO. 3

HEADQUARTERS  
DEPARTMENT OF THE ARMY  
WASHINGTON, D.C., 9 NOVEMBER 1992

Operator's Manual  
for

**LANDING CRAFT, UTILITY  
(LCU 2000 CLASS)  
NSN 1905-01-154-1191**

Approved for public release; Distribution is unlimited

TM 55-1905-223-10, 17 January 1989 is changed as follows:

1. Remove and insert pages as indicated below. New or changed text material is indicated by a vertical bar in the margin. An illustration change is indicated by a miniature pointing hand.

Remove pages

Insert pages

1-73 and 1-74

1-73 and 1-74

-----

1-74.1/(1-74.2 blank)

1-107 and 1-108

1-107 and 1-108

B-61 and B-62

B-61 and B-62

2. Retain this sheet in front of manual for reference purposes.

By Order of the Secretary of the Army:

GORDON R. SULLIVAN  
*General, United States Army*  
*Chief of Staff*

Official:

MILTON H. HAMILTON  
*Administrative Assistant to the*  
*Secretary of the Army*  
03003

DISTRIBUTION:

To be distributed in accordance with DA Form 12-25E, block no. .4821, requirements for  
TM 55-1905-223-1 0.

CHANGE

NO. 2

HEADQUARTERS  
DEPARTMENT OF THE ARMY  
WASHINGTON, D.C., 3 APRIL 1992

Operator's Manual  
for

**LANDING CRAFT, UTILITY  
(LCU 2000 CLASS)  
NSN 1905-01-154-1191**

Approved for public release; distribution is unlimited

TM 55-1905-223-10, 17 January 1989 is changed as follows:

1. Remove and insert pages as indicated below. New or changed text material is indicated by a vertical bar in the margin. An illustration change is indicated by a miniature pointing hand.

Remove pages

a and b  
1-35 through 1-40  
1-43 and 1-44  
1-69 and 1-70  
(2-11 blank)/2-12  
-----  
2-13 and 2-14  
-----  
2-89 through 2-92  
2-107 through 2-114  
-----  
2-299 and 2-300  
2-325 through 2-330  
2-359 and 2-360  
2-365 and 2-366  
-----  
2-381 and 2-382  
2-423 through 2-434  
2-437 through 2-440  
2-455 and 2-456  
2-473 and 2-474  
2-481 through 2-484  
2-497 and 2-498  
2-505 and 2-506  
2-511 and 2-512  
2-517 through 2-520  
2-529 and 2-530  
2-547 and 2-548  
2-563 and 2-564

Insert pages

a and b  
1-35 through 1-40  
1-43 and 1-44  
1-69 and 1-70- . . .  
(2-11 blank)/2-12  
2-12.1 and 2-12.2  
2-13 and 2-14  
2-14.1 and 2-14.2  
2-89 through 2-92  
2-107 through 2-114  
(2-114.1 blank)/2-114.2  
2-299 and 2-300  
2-325 through 2-330  
2-359 and 2-360  
2-365/(2-366 blank)  
2-368.1 through 2-368.4  
2-381 and 2-382  
2-423 through 2-434  
2-437 through 2-440  
2-455 and 2-456  
2-473 and 2-474  
2-481 through 2-484  
2-497 and 2-498  
2-505 and 2-506  
2-511 and 2-512  
2-517 through 2-520  
2-529 and 2-530  
2-547 and 2-548  
2-563 and 2-564

2-569 and 2-570  
2-591 and 2-592  
2-603 and 2-604  
2-611 and 2-612  
2-647 through 2-652  
B-41 and B-42  
B-57 and B-58  
B-67 and B-68  
D-3 through D-8  
Index-17 and Index-18

2-569 and 2-570  
2-591 and 2-592  
2-603 and 2-604  
2-611 and 2-612  
2-647 through 2-652  
B-41 and B-42  
B-57 and B-58  
B-67 and B-68  
D-3 through D-8  
Index-17 and Index-18

2. Retain this sheet in front of manual for reference purposes.

By Order of the Secretary of the Army:

Official:

MILTON H. HAMILTON  
*Administrative Assistant to the  
Secretary of the Army*  
00894

GORDON R. SULLIVAN  
*General, United States Army  
Chief of Staff*

DISTRIBUTION:

To be distributed in accordance with DA Form 12-25E, (qty rqr block no. 4821).



CHANGE

NO. 1

HEADQUARTERS  
DEPARTMENT OF THE ARMY  
WASHINGTON, D.C., 6 April 1990

Operator's Manual for  
LANDING CRAFT, UTILITY  
(LCU 2000 CLASS)  
NSN 1905-01-154-1191

Approved for public release; distribution is unlimited.

TM55-1905-223-10, 17 January 1989, is changed as follows:

1. Remove and insert pages as indicated below. New or changed text material is indicated by a vertical bar in the margin. An illustration change is indicated by a miniature pointing hand.

Remove pages

a/(b blank)  
1-9 through 1-12  
2-149 and 2-150  
2-161 and 2-162  
2-207 and 2-208  
2-225 and 2-226  
-----  
2-241 and 2-242  
2-301 and 2-302  
2-307 and 2-308  
2-351 and 2-352  
-----  
2-429 and 2-430  
2-433 through 2-436  
2-471 and 2-472  
2-483 through 2-490  
2-529 and 2-530  
2-535 and 2-536  
2-613 and 2-614  
2-645 and 2-646  
2-665 and 2-666  
2-669 and 2-670  
2-685 and 2-686  
2-705 through 2-708  
Index 11 through Index 14

Insert pages

a/(b blank)  
1-9 through 1-12  
2-149 and 2-150  
2-161 and 2-162  
2-207 and 2-208  
2-225 and 2-226  
2-226.1/2-226.2  
2-241 and 2-242  
2-301 and 2-302  
2-307 and 2-308  
2-351 and 2-352  
2-352.1/2-352.2  
2-429 and 2-430  
2-433 through 2-436  
2-471 and 2-472  
2-483 through 2-490  
2-529 and 2-530  
2-535 and 2-536  
2-613 and 2-614  
2-645 and 2-646  
2-665 and 2-666  
2-669 and 2-670  
2-685 and 2-686  
2-705 through 2-708  
Index 11 through Index 14

2. Retain this sheet in front of manual for reference purposes.

By Order of the Secretary of the Army:

**CARL E. VUONO**  
*General, United States Army*  
*Chief of Staff*

Official:

**WILLIAM J. MEEHAN, II**  
*Brigadier General, United States Army*  
*The Adjutant General*

DISTRIBUTION:

To be distributed in accordance with DA Form 12-25A, Operator Maintenance Requirements for Landing Craft, Utility, LUC-1671-1679.

**WARNING****MODIFICATION HAZARD**

Unauthorized modifications, alterations or installations of or to this equipment are prohibited and are in violation of AR 750-10. Any such unauthorized modifications, alterations or installations could result in death, injury or damage to the equipment.

**HIGH PRESSURE HYDRAULIC SYSTEM HAZARDS****Hydraulic systems can cause serious injuries if high pressure lines or equipment fail.**

Never work on hydraulic systems or equipment unless there is another person nearby who is familiar with the operation and hazards of the equipment, and who can give first aid. A second person should stand by controls to turn off hydraulic pumps in an emergency.

**MOVING MACHINERY HAZARDS**

Be very careful when operating or working near moving machinery.

Running engines, rotating shafts, and other moving machinery parts could cause personal injury or death.

**ELECTRICAL HAZARDS**

Do not be misled by the term "low voltage." Potentials as low as 50 volts may cause death under adverse conditions. Whenever the nature of the operation permits, keep one hand away from the equipment to reduce the hazard of current flowing through the body.

High pressure exists inside lamps of searchlights and certain floodlights, especially when hot, and under certain conditions could explode causing injury from flying glass and metal particles.

When performing maintenance on the RT-1600/U Receiver/Transmitter and the HF Communication Antennas, safety harness must be worn.

**FLAMMABLE LIQUID AND COMBUSTIBLE VAPOR HAZARDS**

Gasoline, fuel oil, lubricating oil, grease, paint, paint thinner, cleaning solvents and other combustible liquids present a serious fire hazard. Always store combustible liquids in approved containers and in their designated compartments or deck storage locations. Ensure exhaust and ventilation fans are operating while using cleaning solvents or paint products. Never store or charge batteries in a confined space without ventilation or near operating electrical equipment.

When refueling and defueling the vessel, ensure appropriate signs are posted in visible locations and warnings are announced over the vessel's public address system. Smoking, welding and any operation which involves open flames must be prohibited throughout the vessel.

**CAUSTIC AND CORROSIVE CHEMICAL HAZARDS**

Battery acid and water purification chemicals such as bromine and chlorine can cause serious burns to eyes or exposed areas of skin. Always wear eye protection and protective clothing when working with caustic and corrosive chemicals. If chemicals accidentally contact skin or eyes, immediately flush with large quantities of water and seek medical attention.

**COMPRESSED AIR HAZARDS**

High pressure compressed air tanks, piping systems and air operated devices possess potential for serious injury to eyes and exposed areas of skin due to escaping air pressure.

**ELECTROMAGNETIC RADIATION HAZARDS**

Electromagnetic radiation from the searchlight, radar, and radio antennas has the potential for serious radiation burns. Do not stand in the path of radiation emission.

**FIRE SUPPRESSANT HAZARDS**

Fire suppressant chemicals displace oxygen and can cause suffocation. Immediately evacuate areas where they will be used.

**For Artificial Respiration, refer to FM 21-11.**

**Change 2    b**

TECHNICAL MANUAL  
NO. 55-1905-223-10

HEADQUARTERS  
DEPARTMENT OF THE ARMY  
WASHINGTON, D.C., 17 January 1989

**OPERATOR'S MANUAL  
FOR  
LANDING CRAFT, UTILITY  
(LCU 2000 CLASS)  
NSN 1905-01-154-1191**

**REPORTING ERRORS AND RECOMMENDING IMPROVEMENTS**

You can help improve this publication. If you find any mistakes or if you know of a way to improve the procedures, please let us know. Submit your DA Form 2028 (Recommended Changes to Equipment Technical Publications and Blank Forms), through the Internet, on the Army Electronic Product Support (AEPS) website. The Internet address is <http://aeeps.ria.army.mil>. If you need a password, scroll down and click on "ACCESS REQUEST FORM". The DA Form 2028 is located in the ONLINE FORMS PROCESSING section of the AEPS. Fill out the form and click on SUBMIT. Using this form on the AEPS will enable us to respond quicker to your comments and better manage the DA Form 2028 program. You may also mail, fax or E-mail your letter or DA Form 2028 direct to: AMSTA-LC-CI/TECH PUBS, TACOM-RI, 1 Rock Island Arsenal, Rock Island, IL 61299-7630. The E-mail address is [TACOM-TECH-PUBS@ria.army.mil](mailto:TACOM-TECH-PUBS@ria.army.mil). The fax number is DSN 793-0726 or Commercial (309) 782-0726.

DISTRIBUTION STATEMENT A: Approved for public release; distribution is unlimited.

**TABLE OF CONTENTS**

	<u>PAGE</u>
HOW TO USE THIS MANUAL .....	iii
CHAPTER 1 INTRODUCTION .....	1-1
Section I General Information .....	1-1
Section II <u>Equipment Description</u> .....	1-5
Section III Technical Principles of Operation .....	1-73
CHAPTER 2 <u>OPERATING INSTRUCTIONS</u> .....	2-1
Section I <u>Description and Use of Operator's Controls and Indicators</u> .....	2-1
Section II <u>Preventive Maintenance Checks and Services (PMCS)</u> .....	2-207
Section III Operation Under Usual Conditions .....	2-283
Section IV Operation Under Unusual Conditions .....	2-641
CHAPTER 3 MAINTENANCE INSTRUCTIONS .....	3-1

**TABLE OF CONTENTS – Continued**

APPENDIX A REFERENCES..... A-1

APPENDIX B COMPONENTS OF END ITEM AND BASIC ISSUE ITEMS LIST ..... B-1

APPENDIX C ADDITIONAL AUTHORIZATION LIST ..... C-1

**I** APPENDIX D EXPENDABLE AND DURABLE ITEMS LIST..... D-1

APPENDIX E STOWAGE AND SIGN GUIDE FOR COMPONENTS OF END ITEM, BASIC  
ISSUE ITEMS AND APPLICABLE ADDITIONAL AUTHORIZATION LIST  
ITEMS ..... E-1

APPENDIX F SOUNDING TABLES ..... F-1

APPENDIX G INSPECTION CHECKLISTS FOR THE LCU-2000 ..... G-1

ALPHABETICAL INDEX ..... Index 1

## HOW TO USE THIS MANUAL

**GENERAL.** This manual contains description, technical principles of operation, and operating instructions for the Landing Craft, Utility (LCU). The manual is divided into three chapters:

CHAPTER 1, INTRODUCTION, provides general information about the vessel, identifies the major components and systems by deck and compartment, and describes how the components or systems work.

CHAPTER 2, OPERATING INSTRUCTIONS, identifies operating controls and indicators and explains how to use them. Most of the information is organized by the compartment in which it is located. This chapter covers preventive maintenance checks and services (PMCS), how to operate the vessel and its equipment during usual and unusual conditions, and how to respond to certain emergency conditions.

CHAPTER 3, MAINTENANCE INSTRUCTIONS, references the user to the applicable Department of the Army Technical Manual that explains what to do when something goes wrong with the vessel.

**WARNINGS, CAUTIONS, AND NOTES.** Information is provided throughout the manual which does not fit into a procedural step. This information is in the form of WARNINGS, CAUTIONS, and NOTES. WARNINGS are provided where injury may occur to personnel on or near the equipment. WARNING headings are boxed, as shown below:

### **WARNING**

#### RADIO FREQUENCY HAZARD

- Electromagnetic radiation has the potential for serious injury or death.
- Avoid placing your body in the path of radiation emissions.

There are also a number of general WARNINGS listed in the Warning Page which should be read before operating the vessel.

CAUTIONS are provided where equipment may be damaged but no personal injuries should result. The word CAUTION is underlined, as shown below:

### **CAUTION**

Do not hold in START position any longer than necessary to start equipment or the starter will overheat.

NOTES highlight or amplify information to operate the vessel or equipment, but no equipment damage or personnel injury is involved, as shown below:

## HOW TO USE THIS MANUAL - continued

## NOTE

Engine should start within 10 seconds.

WARNINGS, CAUTIONS, AND NOTES SHOULD NEVER BE IGNORED.

INTERNAL REFERENCING. In this manual, internal referencing is done by paragraph number. For example: Align fuel oil transfer piping system (see para. 2-9.a.).

The note (see para. 2-9.a.) refers you to Chapter 2, paragraph 9.a., of this manual. If the paragraph is less than 10 lines or 200 words, the information will be repeated and not referred to.

For quick reference to a vessel item or procedure, use the alphabetical index in the back of this manual.

Operating procedures that involve valves will contain the valve number, followed by the valve name, followed by the illustration callout number in parenthesis.

EXTERNAL REFERENCING. Referencing outside this manual will be by the military publication number. For example: Clean and lubricate (see LO 55-1905-223-12). The note (see LO 55-1905-223-12) refers you to the lubrication order for the Landing Craft, Utility (LCU) vessel.

PROBLEMS AND MALFUNCTIONS. The vessel may not work properly during operation. When malfunctions occur, the operator should go to the appropriate page of the equipment technical manual (TM 55-1905-223-24-series) and look for the problem in the symptom (malfunction) index of the troubleshooting section. This index will direct the operator to identify exactly what is wrong and correct it. The procedure may direct the operator to other sections of the manual, such as Maintenance. When the operator has done all that can be done and the problem still exists, the operator will be directed to notify higher maintenance. If there is no procedure provided in the symptom (malfunction) index to correct the problem, then the operator should notify higher maintenance.

APPENDIXES. There are six appendixes that provide additional information needed to operate the vessel. Various lists of equipment and supplies, sounding tables, and other general information are provided. The appendixes are lettered A through F.

SECTION INDEXES. Section indexes are provided for each section in chapter 2 to assist you in locating the desired information.

ALPHABETICAL INDEX. Items and operations are listed in alphabetical order by paragraph number.

LOCATION TERMS. The terms starboard (STBD), port, forward, and aft are used to describe areas of the vessel. The location terms refer to the right side (STBD), left side (PORT), front (FORWARD), or rear (AFT) standing in the pilothouse facing the bow ramp of the LCU.

















HOW TO USE THIS MANUAL - continued

ILLUSTRATIONS AND TEXT. Locator views are included wherever necessary. An arrow is used to show the general location of the equipment referred to in the text. An arrow connects the point of interest to an overall view of the equipment. Callout numbers identifying parts appear on the art and in parentheses in the text.

PIPING DIAGRAMS. Piping diagrams show the general location of valves, diverters, pumps, etc. Piping between these locations is functional and may not reflect the "as installed" piping. In small areas where a number of items are located, you will see a circle with a note (for example, SEE DETAIL A).

The detailed diagram will be found after the first sheet and will be labeled to match the note. See the table below for a legend of piping symbols used.

SYMBOL	DESCRIPTION
	VALVE providing ON-OFF CONTROL
	RELIEF VALVE
	STRAINER
	EDUCTOR
	CHECK VALVE
	PUMP
	KEEL COOLER (INLET OR OUTLET)
	HAND PUMP

SYMBOL	DESCRIPTION
	REACH ROD HAND WHEEL
	CONNECTOR (indicator vertical continuation of piping)
	CONNECTOR (indicator same-deck continuation of piping)
	CONNECTOR, provides means of tracing piping between sheets
	DIVERTER, directs flow between three pipes
	WATER HEATER
	DRAIN
	REGULATOR

CHAPTER 1  
INTRODUCTION

	<u>Page</u>
Section I. General Information .....	1-1
Section II. Equipment Description .....	1-5
Section III. Technical Principles of Operation .....	1-73

**Section I. GENERAL INFORMATION**

1-1. **Scope.** This is an operator's manual for the 2000 Class Landing Craft, Utility (LCU) (See FIGURE 1-1). The LCU is designed to transport cargo from ships offshore to shore and to transport cargo to areas that cannot be reached by ocean going vessels. The LCU can carry rolling stock (trucks, tanks, and other vehicles) and dry cargo. The vessel can operate in coastal waters and on the open ocean. It can beach and retract itself on remote coastlines and undeveloped port areas. Because of its shallow draft, the LCU can carry cargo from deep drafted ships to shore in ports or areas too shallow for larger ships. The LCU is also capable of deploying overseas under its own power.

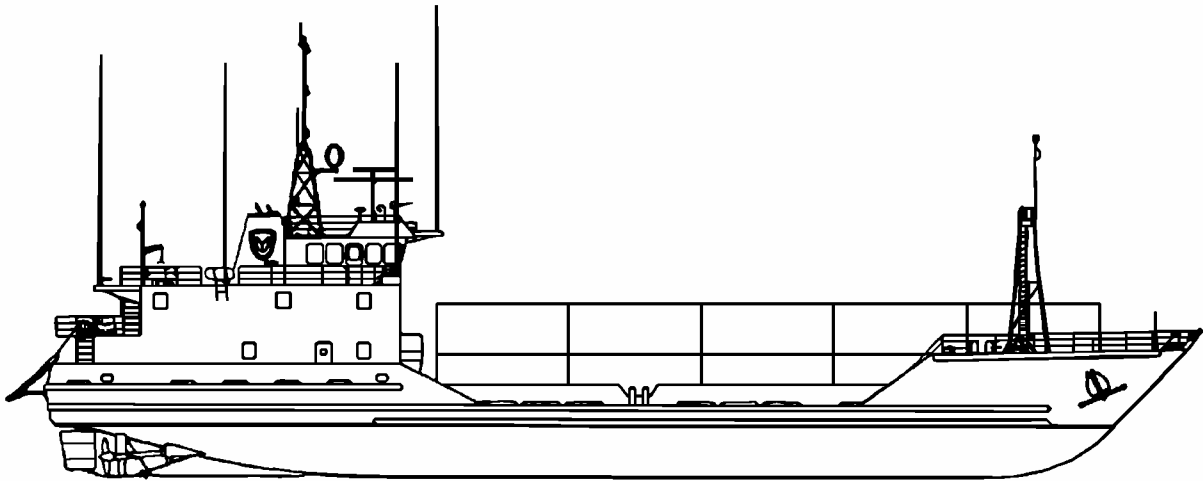

*FIGURE 1-1. Landing Craft, Utility*

1-2. **Hand Receipt (HR) Manuals.** Not applicable.

1-3. **Reporting Equipment Improvement Recommendations (EIRs).** If your LCU needs improvement, let us know. Send us an EIR. You the user are the only one who can tell what you don't like about the equipment. Let us know why you don't like the design or performance. Put it on an SF 368 (Quality Deficiency Report). Mail the SF 368 to us at Commander, US Army Tank-automotive and Armaments Command, AMSTA-LC-CIP-WT, Rock Island, IL 61299-7630. We will send you a reply.

1-4. **Warranty.** Refer to TB 55-1905-223-24, Warranty Procedures for Landing Craft Utility (LCU).

1-5. **Cross Reference List For Selected CECOM Equipment.** A cross reference list for commercial electronic equipment recently type classified is provided in Table 1-1. This list provides a cross reference from the equipment description to both official government nomenclature and commercial identification.

**Table 1-1. Cross Reference List for Selected Communications-Electronics Equipment**

NO.	DESCRIPTION	NOMENCLATURE	COMMERCIAL IDENTIFICATION
1	Radar Set (3 cm)	AN/SPS-64(V)16	AN/SPS-64
2	Radar Set (10 cm)	AN/SPS-64(V)17	AN/SPS-64
3	Radar Interswitch Unit	SA-2308/SPS-64(V)	SA 2308
4	Radio Set	AN/SRD-26	4005A
5	Sonar Sounding Set	AN/SQN-21	D600D
6	Radio Frequency Amplifier	AM-7387/URC	MSR 1020
7	Power Supply	PP-8236/URC	MSR 6212
8	Antenna Coupler	CU-2417/URC	MSR 4030
9	Facsimile Recorder Reproducer	RD-605/UXH	TR-1
10	Receiver Transmitter	RT-1600/U	6100
11	Alarm Signal Generator	SG-1319/SCN	MR 370-13A
12	Radio Receiver	R-2414/SRA	M1511
13	Telegraph Terminal	AN/SGC-14	RF3500
14	Radio Receiver	R-2408/URC	MSR 5050
15	Radio Transmitter	T-1527/URC	MSR 6700

Table 1-1. Cross Reference List for Selected  
Communications-Electronics Equipment (Continued)

NO.	DESCRIPTION	NOMENCLATURE	COMMERCIAL IDENTIFICATION
16.	Receiver-Transmitter	RT-1588/SRQ	403A
17.	Communication Modem	MD-1255/URC	1280A
18.	Interface Unit	J-4795/U	6606
19.	Electronic Equipment Installation Kit	MK-2453/G	MK-2453
20.	Sound Measuring Set	AN/SQN-20	DSL-150
21.	Radio Set	AN/PRC-129	RPX-150
22.	Satellite Signals Navigation Set	AN/WRN-6(V)2	



Section II. EQUIPMENT DESCRIPTION

1-6. Equipment Characteristics, Capabilities, and Features. These are given in the following subparagraphs.

a. Characteristics. The LCU is designed to carry 350 short tons of dry cargo on the cargo deck. Deck cargo can include:

- Standard containers
- Pallets
- Army vehicles
- M-1 Tanks
- Crane
- Container handler
- General cargo

b. Capabilities. The LCU is capable of self-delivery to overseas locations, has a maximum range of 4500 nautical miles with 25% fuel reserve, can land and retract from undeveloped coastlines under full load, and can deliver cargo to terminal areas not accessible to deep draft vessels.

c. Features. The LCU features discharge and backloading of other ships and provides roll on/roll off (RO RO) delivery for portable equipment. It is capable of carrying cargo from ship-to-shore in a minimum of four feet of water.

1-7. Location and Description of Major Components. External and internal illustrations show the location of major components and compartments of the LCU.

a. LCU Decks. Items shown on FIGURE 1-2 are described as follows:

(1) Pilothouse top. The pilothouse top (weather deck) contains radar antennas, searchlights, foam fire station, fire monitors, gyro repeater, satellite signals navigation set antenna and antenna amplifier, the binnacle compass and supports for cargo lights.

(2) 02 Level. The 02 Level includes, but is not limited to, the pilothouse and poop deck.

(3) 01 Level. The 01 Level includes, but is not limited to, crew accommodations, stern anchor winch, and the aft damage control locker.

(4) Main deck. The main deck includes, but is not limited to, the provisions storeroom, galley, mess room, recreation room, sick bay, arms control room, the air conditioning and emergency generator room, paint locker, boatswains locker, and the forward damage control locker.

(5) Forecastle deck. The forecastle deck (weather deck) is fitted with the anchor windlasses port and starboard bits, chain stopper, and roller fairlead.

(6) Below main deck. Below the main deck are the steering gear compartment, ballast, fuel, and water tanks, fire station, engine room, tunnel, bowthruster compartment, machine shop, stowage compartments, and engine operating station.

(7) DIMENSIONS

CARGO DECK	11' 6"
RAISED MAIN DECK	14' 9"
01 LEVEL DECK	22' 9"
02 LEVEL DECK	30' 9"
PILOT HOUSE TOP	38' 9"
TOP OF MAIN MAST	69' 9" (MAST HEAD LIGHT)
TOP OF HIGHEST ANTENNA (MAIN MAST)	72' 3"
TOP OF FWD MAST	55' 8" (AT NAV LIGHT)
TOP OF ANTENNA	77' 9" (FWD MAST)

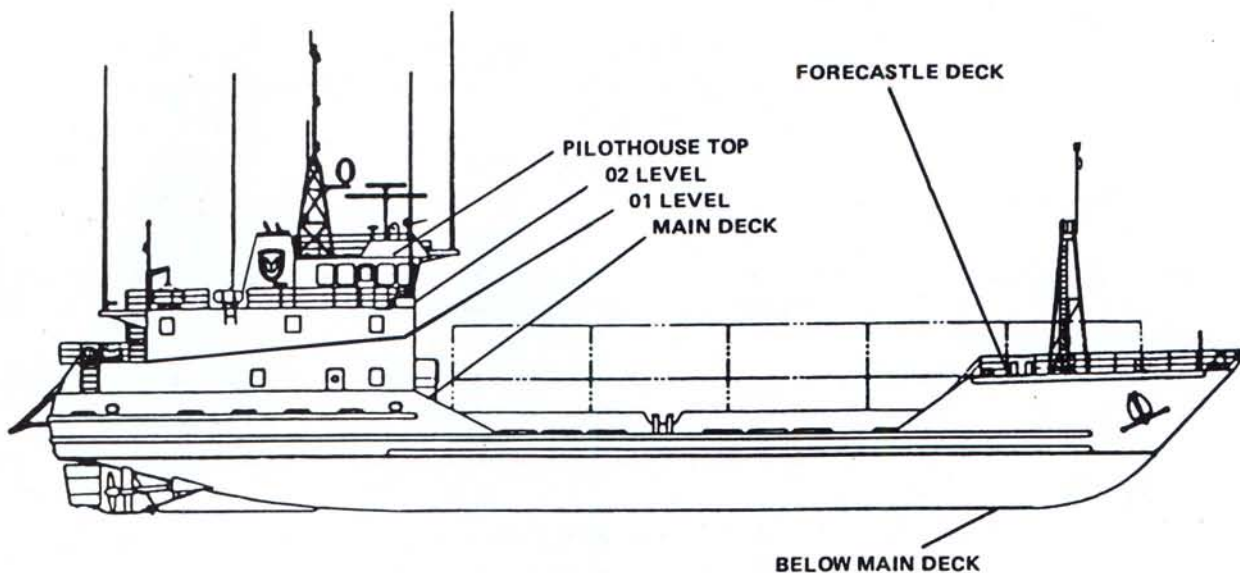

FIGURE 1-2. LCU Decks.

b. LCU External Features. FIGURE 1-3, sheets 1 through 3, shows the LCU external views. Sheet 1 shows the ship's profile to include top and starboard features. Sheet 2 displays the ship's antenna arrangement. Sheet 3 shows the countermeasure washdown system. FIGURE 1-4 shows the pilothouse deck equipment and the 02 level. FIGURE 1-5 shows the 01 level deck equipment. FIGURE 1-6 shows the main deck equipment. FIGURE 1-7 shows the equipment contained on the forecastle deck.

(1) LCU profile. Items shown on sheet 1 of FIGURE 1-3 are described as follows:

(a) Stern anchor (1). The stern anchor is a Danforth type weighing 2000 pounds with 1200 feet of galvanized wire rope. A turn buckle is provided to secure the anchor when stowed in the anchor rack.

(b) Bow anchor (port and starboard) (2). Two Danforth type, each weighing 1700 pounds are self-stowing anchors. Each anchor has a shackle and swivel. Port anchor has 6 shots of chain, starboard has 7 shots of chain.

(c) Hull (3). The hull is all steel, having continuous sealtight welding with full continuity of structural members.

(d) Propeller shaft (port and starboard) (4). Shafts of solid steel that transfer power from the reduction gear to the propellers.



(e) Rudder (port and starboard) (5). Rudders are welded steel, watertight, with drain and vent plugs for testing, preserving, and draining. The rudders are offset inboard of the propellers.

(f) Mast (6). The mast is used to support communications antennas, navigational antennas, navigation lights, and signal horn.

(g) Cargo deck (7). The cargo deck is approximately 100 feet long and 38 feet wide and is equipped with recessed cargo securing devices and has a profile suitable for (RO/RO) roll on/roll off cargo. Maximum cargo load is 350 short tons.

(h) Foremast (8). The foremast is free standing atop a support which bridges either side of the forecastle deck. It is used to support navigation lights.

(i) Bow ramp (9). The 16-foot wide, 22-foot long, 35 ton bow ramp is used to load and off-load vehicles and equipment.

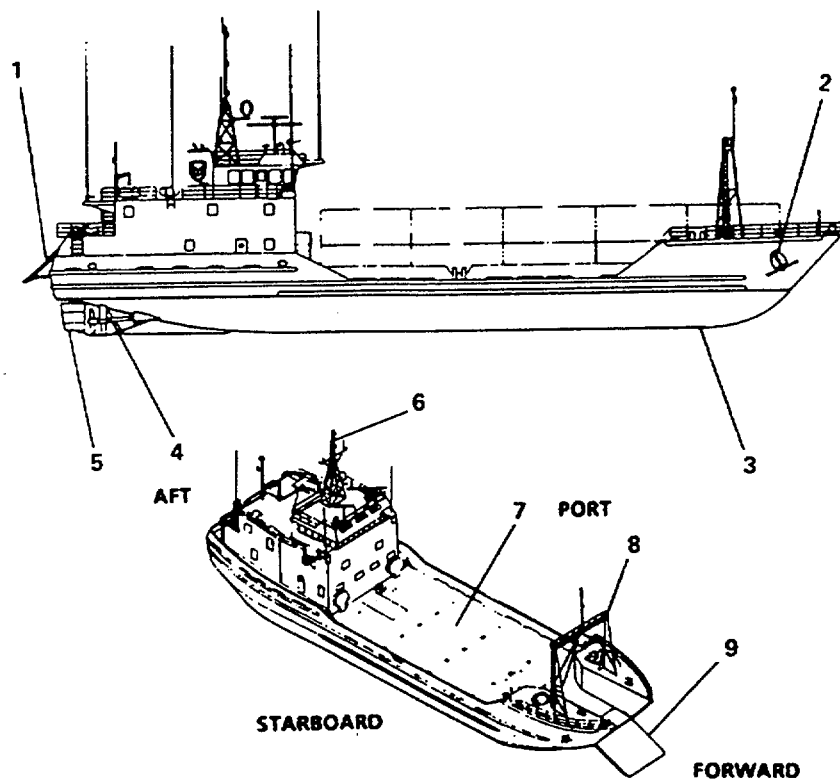

**LEGEND**

- |                                       |               |
|---------------------------------------|---------------|
| 1. STERN ANCHOR                       | 6. MAST       |
| 2. BOW ANCHOR (PORT & STARBOARD)      | 7. CARGO DECK |
| 3. HULL                               | 8. FOREMAST   |
| 4. PROPELLER SHAFT (PORT & STARBOARD) | 9. RAMP       |
| 5. RUDDER (PORT & STARBOARD)          |               |

FIGURE 1-3. LCU External Features (Sheet 1 of 3).

- (2) (LCU antenna arrangement. Sheet 2 of FIGURE 1-3 shows the location of the following antennas:
- (a) Receiver/Transmitter (RT-1600/U) (10).
  - (b) Automatic Direction Finder (ADF) sense (AN/SRD-26) (11) -
  - (c) Automatic Direction Finder (ADF cross-loop (AN/SRD-26) (12)
  - (d) IFF (Identification Friend or Foe) Transponder (AN/APX-72) (13).
  - (e) Omega Navigation Set (AN/SRN-23) (14).
  - (f) Radio Set (AN/URC-80) (15)
  - (g) Radio Set (AN/VRC-46) (16).
  - (g.1) Antenna (AS-3819/SRN) (16A).
  - (h) Receiver (R-2408/URC) (17).
  - (i) Radio Set AN/URC-92) (18).
  - (j) Radar Set (3 cm) S Band (AS-3194/SPS-64(V),16) (19).

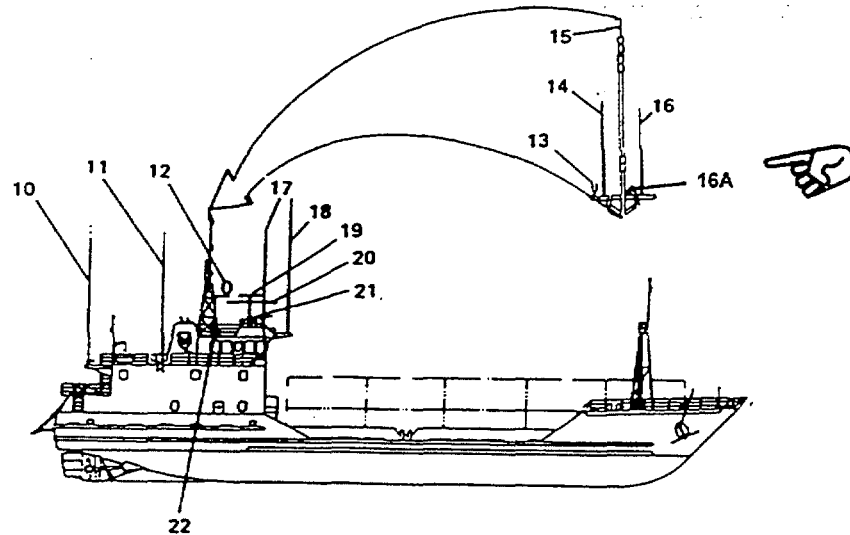

**LEGEND**

- |   |  |
|---|--|
| <ul style="list-style-type: none"> <li>10. RECEIVER/TRANSMITTER (RT-1600/U)</li> <li>11. AUTOMATIC DIRECTION FINDER (ADF) SENSE (AN/SRD-26)</li> <li>12. AUTOMATIC DIRECTION FINDER (ADF) CROSS-LOOP (AN/SRD-26)</li> <li>13. IFF (IDENTIFICATION FRIEND OR FOE) TRANSPONDER (AN/APX-72)</li> <li>14. OMEGA NAVIGATION SET (AN/SRN-23)</li> <li>15. RADIO SET (AN/URC-80)</li> <li>16. RADIO SET (AN/VRC-46)</li> </ul> | <ul style="list-style-type: none"> <li>16A. ANTENNA (AS-3819/SRN)</li> <li>17. RECEIVER (R-2408/URC)</li> <li>18. RADIO SET (AN/URC-92)</li> <li>19. RADAR SET (3 CM) S BAND (AS-3194/SPS-64(V)16)</li> <li>20. RADAR SET (10 CM) X BAND (AS-3195/SPS-64(V)17)</li> <li>21. (ENTERTAINMENT TV AND RADIO</li> <li>22. FACSIMILE RECORDER REPRODUCER (RD-605/UXH)</li> </ul> |
|---|--|

FIGURE 1-3. LCU External Features (Sheet 2 of 3).  
Change 6 1-8

- (k) Radar Set (10 cm) X Band (AS-3195/SPS-64(V)17) (20).
  - (l) Entertainment TV and Radio (21).
  - (m) Facsimile Recorder-Reproducer (RD-605/UXH) (22).
- (3) Countermeasure washdown system. Piping system to washdown the LCU superstructure, pilohouse top, and raised main deck in a nuclear, biological, or chemical (NBC) environment is shown on Sheet 3, FIGURE 1-3.

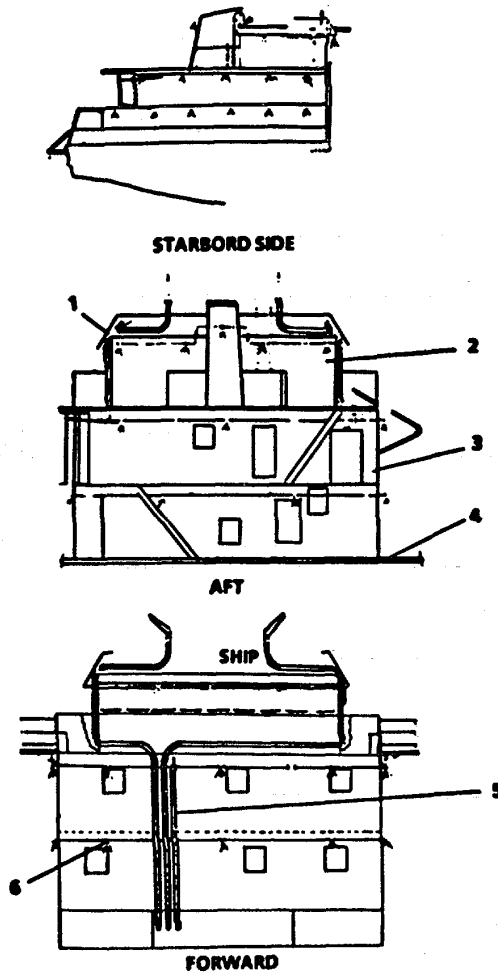

**LEGEND**

- 1. PILOTHOUSE TOP
- 2. 02 LEVEL
- 3. 01 LEVEL

- 4. MAIN DECK
- 5. WASHDOWN PIPING
- 6. SPRAY HEAD

FIGURE 1-3. LCU External Features (Sheet 3 of 3).

- (4) Pilothouse deck - 02 Level. FIGURE 1-4 shows the pilothouse top and 02 level.
- (a) Rescue/workboat crane (1). An electric winch powered crane for handling the rescue/workboat (4100 pounds capacity).
  - (b) Rescue/workboat (2). A six-person rigid bottom inflatable boat, 13 feet long, with a 40 horsepower outboard engine (29) and two 6 gallon fuel tanks.
  - (c) Adjustable flood light (3) Used for night time illumination for the rescue/workboat and surrounding area.
  - (d) starboard,(d) Liferaft (4). The LCU has three 15 - person liferafts, one port, one starboard, and one midships.
  - (e) Fire station (5). 02 Level fire fighting station using seawater having 50 feet of 1-1/2 inch hose with an all-purpose nozzle.
  - (f) Ammo locker (6). An ammunition locker is mounted near each .50 caliber gun mount, port and starboard. Capacity of locker is six .50 caliber ammo cans.
  - (g) Communications batteries (7). Waterproof container holding four, 6 volt batteries for the communications equipment.
  - (h) .50 Caliber gun mount (8). Two .50 caliber gun mounts are installed, one port and one starboard.
  - (i) Gaylord hood exhaust (9). Exhaust hood for Gaylord hood over the cooking area of the galley.
  - (j) Deck floodlight (10). Six deck floodlights are provided, three forward, two aft on the pilothouse and one aft on the 02 Level. Each floodlight has a 400W mercury vapor lamp.
  - (k) Foam fire station number 1 (11). Pilothouse top fire station that can use either seawater or foam having 75 feet of 2-1/2 inch hose and an all-purpose nozzle.
  - (l) Mast (12). Used to support navigational lights, communication antennas, ship's horn, and signal flag and ensign hoists.
  - (m) Radar antenna (13). Antenna set (AS-3195/SPS-64(V)17) provides 360 degree sweep for the S Band (10 cm) radar.
  - (n) Side light box (14). Two side light boxes are provided, each box contains two side lights, port lights (red) and starboard lights (green).
  - (o) Gyro repeater (15). Provides remote indication of the ship's heading as relayed by the ship's compass, one port, one starboard, and on pilothouse top.
  - (p) Rudder angle indicator (16). Rudder angle indicators show the position of the rudder in relation to the center line of the LCU. One port and one starboard on the bridge weather deck.

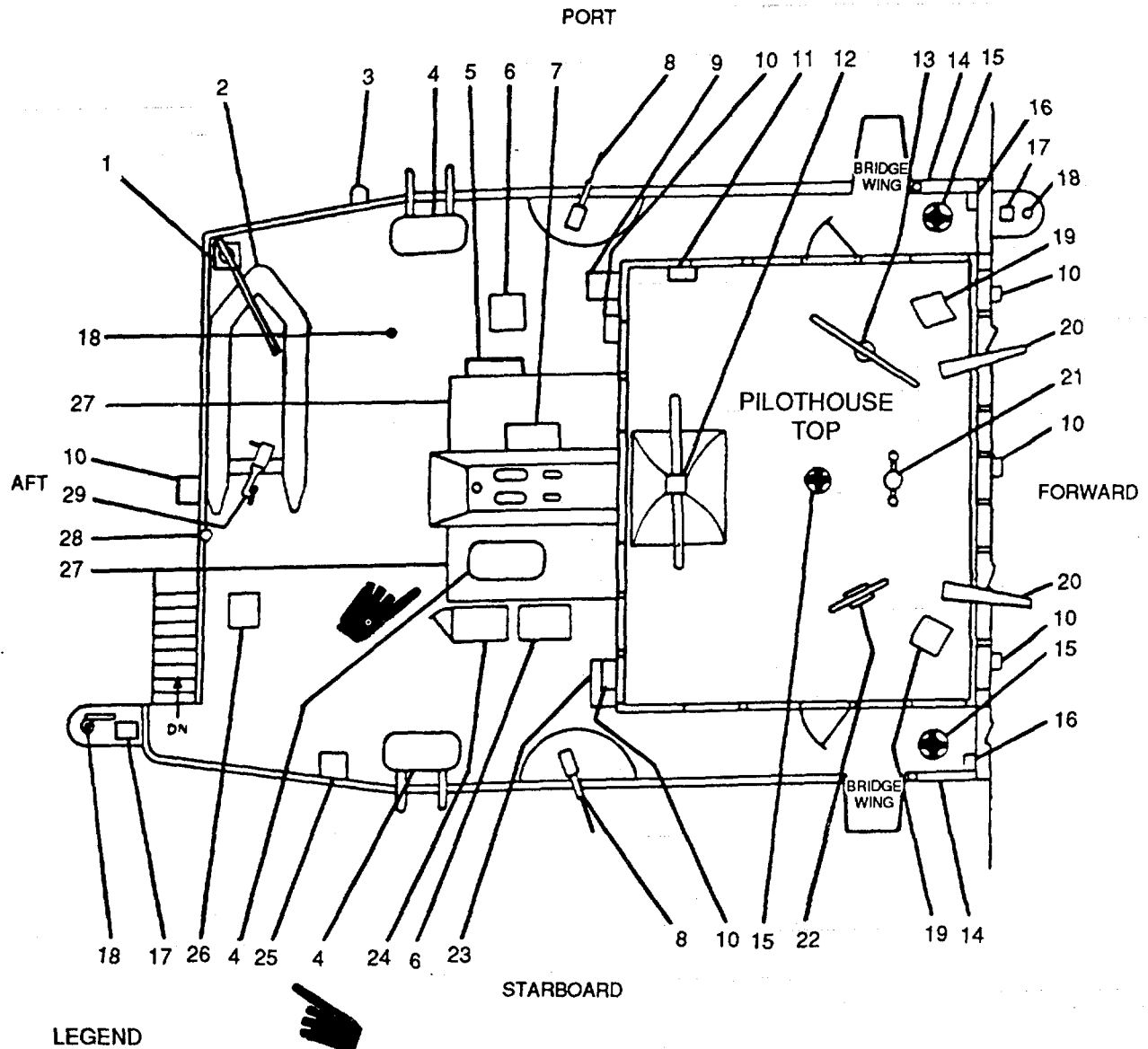

**LEGEND**

- |  |  |
|--|--|
| <ul style="list-style-type: none"> <li>1. RESCUE/WORKBOAT CRANE</li> <li>2. RESCUE/WORKBOAT</li> <li>3. ADJUSTABLE FLOODLIGHT</li> <li>4. LIFERAFT</li> <li>5. FIRE STATION</li> <li>6. AMMO LOCKER</li> <li>7. COMMUNICATION BATTERIES</li> <li>8. .50 CAL GUN MOUNT</li> <li>9. GAYLORD HOOD EXHAUST</li> <li>10. DECK FLOODLIGHT</li> <li>11. FOAM FIRE STATION</li> <li>12. MAST</li> <li>13. RADAR ANTENNAE</li> <li>14. SIDE LIGHT BOX</li> <li>15. GYRO REPEATER</li> </ul> | <ul style="list-style-type: none"> <li>16. RUDDER ANGLE INDICATOR</li> <li>17. ANTENNA COUPLER</li> <li>18. 35 FOOT WHIP ANTENNA</li> <li>19. SEARCHLIGHT</li> <li>20. FIRE MONITOR</li> <li>21. MAGNETIC COMPASS</li> <li>22. RADAR ANTENNA</li> <li>23. PYROTECHNIC SIGNAL LOCKER</li> <li>24. GRENADE-MK 3A1 LOCKER</li> <li>25. CREWS HEAD EXHAUST</li> <li>26. GRENADE FUSE M206A1 LOCKER</li> <li>27. ENGINE EXHAUST FAN</li> <li>28. STERNLIGHT MAST</li> <li>29. OUTBOARD MOTOR</li> </ul> |
|--|--|

FIGURE 1-4. Pilothouse Top and O2 Level External Features.

- (q) Antenna coupler (17). Antenna coupler (CU-2417/URC) connects selected radio sets to the whip antenna.
- (r) 35 Foot whip antenna (18). Used to send HF or VHF radio signals.
- (s) Searchlight (19). Two 500 watt Xenon searchlights are mounted on the pilothouse top, one port and one starboard, controlled from the pilothouse.
- (t) Fire monitor (20). Used to direct fire main water or foam 360 degrees onto the cargo deck or another ship.
- (u) Magnetic compass (21). Ship's magnetic compass installed on a periscope binnacle. Periscope is displayed in the pilothouse.
- (v) Radar antenna (22). Antenna set (AS-3194/SPS-64(V)16) provides 360 degree sweep for the X Band (3 cm) radar.
- (w) Pyrotechnic signal locker (23). The pyrotechnic signal locker is the storage area for ship's flares.
- (x) Grenade-MK 3A1 locker (24). Storage for the anti-personnel grenades.
- (y) Crews head exhaust (25). Exhaust hood for the fan in the crews head.
- (z) Grenade fuse M206A1 locker (26). Storage for the anti-personnel grenade fuses.
- (aa) Engine exhaust fan (27). Exhaust fans for the engine room, one port and one starboard.
- (ab) Sternlight mast (28). Mast for the LCU's sternlight.
- (ac) Outboard motor (29). Mariner 40 horsepower, manual start outboard motor for the rescue/workboat.

(5) 01 Level. The external features of the stern area of this level are shown on FIGURE 1-5.

- (a) Gangway connection brackets (1). Brackets used to support gangway when docked.
- (b) Closed chock, port and starboard (2). Used to guide mooring rope over the ship's stern.
- (c) Shore power connection box (3). Use to attach shore power cable to provide shore power to the LCU electrical system.
- (d) Telephone storage box (4). Stowage for the sound powered head set-chest set.
- (e) Double bitt, port and starboard (5). Used to secure (moor) the LCU.
- (f) Emergency generator fuel oil day tank vent (6).

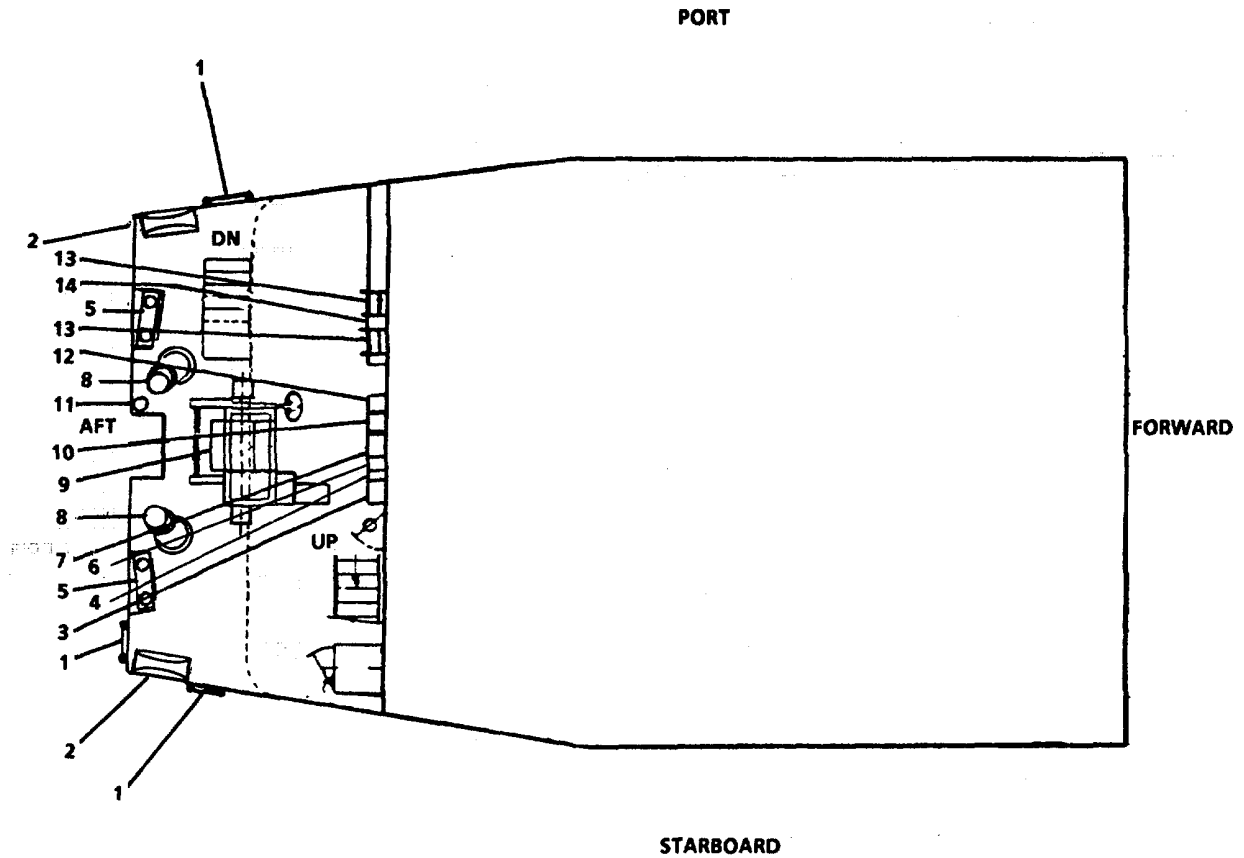

**LEGEND**

- |   |   |
|---|---|
| 1. GANGWAY CONNECTION BRACKETS                | 8. ROLLER FAIRLEAD (P/S)                |
| 2. CLOSED CHOCK (P/S)                         | 9. STERN ANCHOR WINCH                   |
| 3. SHORE POWER CONNECTION BOX                 | 10. FLOODLIGHT-400 WATT                 |
| 4. TELEPHONE STORAGE BOX                      | 11. ENSIGN STAFF                        |
| 5. DOUBLE BITT                                | 12. STERN ANCHOR WINCH MOTOR CONTROLLER |
| 6. EMERGENCY GENERATOR FUEL OIL DAY TANK VENT | 13. TOWING HAWSER REEL (2)              |
| 7. SOUND POWERED TELEPHONE                    | 14. EMERGENCY GENERATOR BATTERY BOX     |

FIGURE 1-5. 01 Level External Features.

- (g) Sound powered telephone (7). Used for internal ships communication.
- (h) Roller fairlead, port and starboard (8). Used for handling and guiding heavy lines.
- (i) Stern anchor winch (9). Used for raising and lowering the stern anchor and mooring the LCU for mooring.
- (j) Floodlight (400 watt) (10). Provides lighting for Stern Anchor Winch and surrounding deck.
- (k) Ensign staff (11). Staff to hoist while moored or at anchor.
- (l) Stern anchor winch motor controller (12). Provides electrical overload protection and control for the stern anchor winch.
- (m) Towing hauser reel (13). Provides storage for towing hausers.
- (n) Emergency generator battery box (14). Provide 24v battery back-up power to start the Emergency Generator.

(6) Main deck External features of the main deck are shown on FIGURE 1-6.

- (a) Aft section of the main deck. Sheet 1 of FIGURE 1-6 shows the external features of the aft section of the main deck.
  - 1 Exhaust from steering compartment (1). Exhaust vent to expel air from the steering compartment.
  - 2 Sea water ballast tank SW-8P access plate (2). Manhole cover for access to SW-8P.
  - 3 Emergency fuel shutdown for day tanks (port and starboard) (3). Used to shut-off fuel from day tanks in an emergency.
  - 4 Socket for portable davit (port and starboard) (4). Provides for mounting a hand operated davit for handling vessel stores.
  - 5 Fire station number 3 (5).
  - 6 Engine room equipment removal soft patch (port and starboard) (6). Watertight soft panel, can be removed to allow removal of engine room equipment.
  - 7 Dirty lube oil discharge point (port and starboard) (7). Used when emptying the dirty lube oil tank.
  - 8 Fresh water sounding tube (port and starboard) (8). Used when sounding fresh water tanks.
  - 9 Engine room supply fan (port and starboard) (9). Provides supply air to engine room.
  - 10 Fuel oil station and catchment (port and starboard) (10). Used to take-on fuel oil.



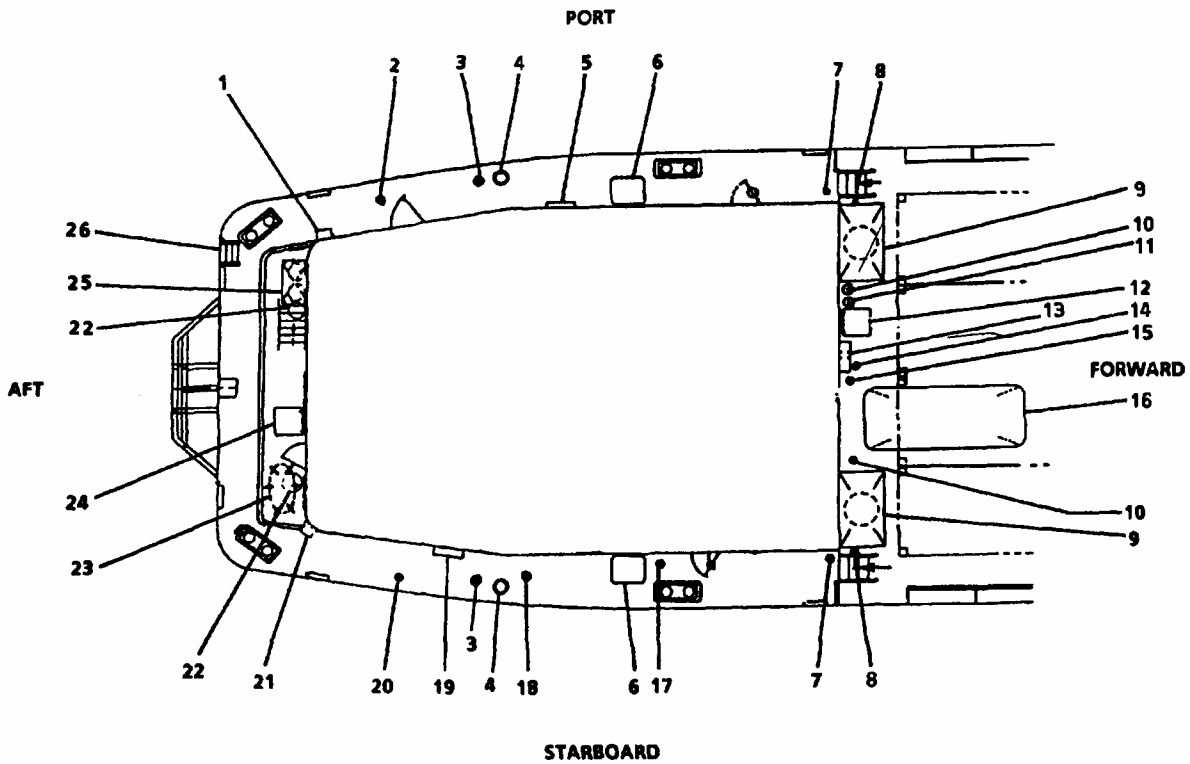

**LEGEND:**

- |  |  |
|--|--|
| 1. EXHAUST FROM STEERING GEAR COMPARTMENT          | 14. SHIP'S BELL                          |
| 2. SEA WATER BALLAST SW-8P ACCESS PLATE            | 15. FRESH WATER MAKEUP                   |
| 3. EMERGENCY FUEL SHUTDOWN FOR DAY TANKS (P/S)     | 16. ENGINE ACCESS SOFT PATCH             |
| 4. SOCKET FOR PORTABLE DAVIT (P/S)                 | 17. MARINE SANITATION DEVICE VENT        |
| 5. FIRE STATION NUMBER 3                           | 18. LUBE OIL SUPPLY POINT                |
| 6. ENGINE ROOM EQUIPMENT REMOVAL SOFT PATCH, (P/S) | 19. FIRE STATION NUMBER 4                |
| 7. DIRTY LUBE OIL DISCHARGE POINT, (P/S)           | 20. SEA WATER BALLAST SW-8S ACCESS PLATE |
| 8. FRESH WATER SOUNDING TUBES, (P/S)               | 21. INTAKE FOR STEERING COMPARTMENT      |
| 9. ENGINE ROOM SUPPLY FAN, (P/S)                   | 22. RUDDER POST ACCESS PLATE             |
| 10. FUEL OIL STATION AND CATCHMENT, (P/S)          | 23. SHORE POWER CABLE STOWAGE            |
| 11. HYDRAULIC OIL FILLING POINT AND CATCHMENT      | 24. STEERING COMPARTMENT HATCH           |
| 12. ENGINE ROOM EMERGENCY ESCAPE HATCH             | 25. TRASH CAN RACK                       |
| 13. ENGINE ROOM HALON RELEASE                      | 26. GASOLINE QUICK JETTISON STORAGE RACK |

FIGURE 1-6. Main Deck External Features (Sheet 1 of 2).

- 11 Hydraulic oil filling point and catchment (11). Used to take on hydraulic oil.
- 12 Engine room emergency escape hatch (12). Provide emergency escape and/or access to the engine room.

**NOTE**

**Not applicable to vessels with FM-200 Fire Suppressant System installed. Reference paragraph 2-46 through 2-47, for FM-200 and Water Washdown System operation. Reference TM 55-1905-243-24&P, LCU-2000, FM-200 Fire Fighting System, for maintenance and installation of FM-200 components.**

- 13 Engine room HALON release (13). Allows remote actuation of engine room HALON system.
- 14 Ship's bell (14).
- 15 Fresh water make-up (15). Used to take on fresh water.
- 16 Engine access soft patch (16). Watertight soft panel can be removed to allow removal of engine room equipment.
- 17 Marine sanitation device vent (17).
- 18 Lube oil supply point (18). Used to take on lube oil.
- 19 Fire station number 4 (19).
- 20 Sea water ballast tank SW-8S access plate (20). Manhole cover for access to SW-8S.
- 21 Intake for steering compartment (21). Intake vent to supply fresh air for the steering compartment.
- 22 Rudder post access plate (22). Plate can be removed to allow removal of rudder post.
- 23 Shore power cable stowage (23).
- 24 Steering compartment hatch (24). Entrance and exit to steering compartment.
- 25 Trash can rack (25).
- 26 Gasoline quick jettison storage rack (26). Storage for 5 gallon gasoline cans.

- (b) Forward section of the main deck. Sheet 2 of FIGURE 1-6 shows components of forward portion of the main deck.

**NOTE**

**Not applicable to vessels with FM-200 Fire Suppressant System installed. Reference paragraph 2-46 through 2-47, for FM-200 and Water Washdown System operation. Reference TM 55-1905-243-24&P, LCU-2000, FM-200 Fire Fighting System, for maintenance and installation of FM-200 components.**

- 1 Manual pull station or HALON system (26). Provides remote activation of paint locker HALON system.
- 2 Fire pull box (27). Provides remote activation of fire detection system.
- 3 Work davit, port and starboard (28). Hand operated davit for handling vessel stores.

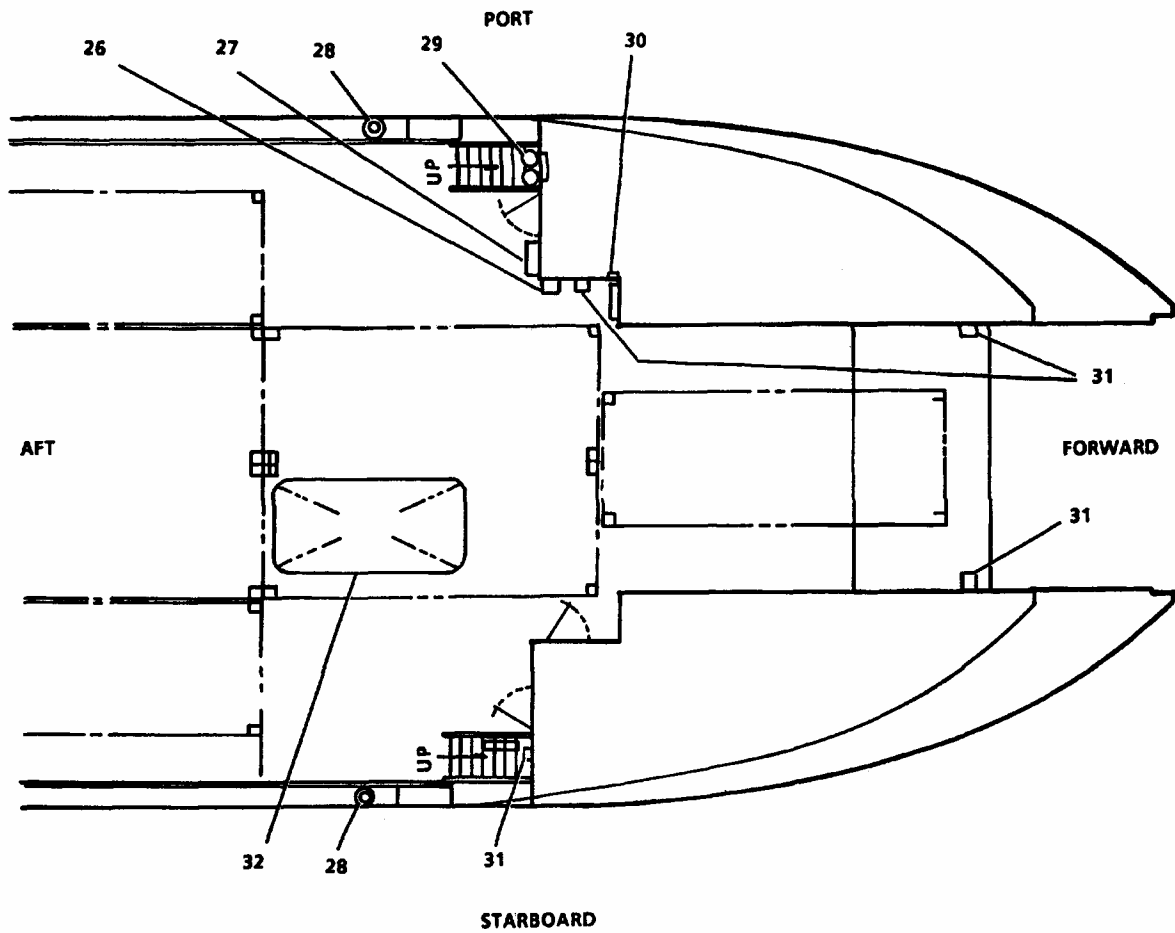

**LEGEND:**

- |  |   |
|--|---|
| 26. MANUAL PULL STATION FOR HALON SYSTEM | 30. FIRE STATION NUMBER 5                 |
| 27. FIRE PULL BOX                        | 31. VENT                                  |
| 28. WORK DAVIT (PORT AND STARBOARD)      | 32. BOWTHRUSTER COMPARTMENT<br>SOFT PATCH |
| 29. HALON BOTTLES                        |   |

FIGURE 1-6. Main Deck External Features (Sheet 2 of 2).

**NOTE**

**Not applicable to vessels with FM-200 Fire Suppressant System installed. Reference paragraph 2-46 through 2-47 for FM-200 and Water Washdown System operation. Reference TM 55-1905-243-24&P, LCU-2000, FM-200 Fire Fighting System, for maintenance and installation of FM-200 components.**

- 4 HALON bottles (29). HALON supply for paint locker HALON fire suppression system.
  - 5 Fire station number 6 (30).
  - 6 Vent (31). Provides ventilation for paint locker and boatswains locker.
  - 7 Bowthruster compartment soft patch (32). Watertight soft panel can be removed to allow removal of bowthruster compartment equipment.
- (7) Forecastle deck. Items shown on FIGURE 1-7 for the forecastle deck are as follows:
- (a) Closed chock (1). Guide for mooring line and towing bridle, two port and two starboard.
  - (b) Double bitt (2). Metal posts used for mooring the ship with lines and hawsers, two port and two starboard.
  - (c) Bow anchor windlass (3). Used to raise and lower the bow anchor. An extended shaft drives the wildcat and gypsy. A clutch assembly is provided on the inboard extended shaft to act as an emergency bow ramp winch, one port and one starboard.
  - (d) Devil's claw (4). Ratchet operated device to hold and lock the anchor chain in place.
  - (e) Fairlead roller (5). Roller used to guide lines and hawsers to desired direction, one port and one starboard.
  - (f) Chain stopper (bow anchor) (6). Locks anchor chain in place.
  - (g) Hawsepipe (7). A pipe through the deck and hull in which the bow anchor chain is guided. When bow anchor is hawsed, its shank is stored in the hawsepipe.
  - (h) Wildcat (bow ramp) (8). Used to guide the ramp chains for either raising or lowering the ramp.
  - (i) Jackstaff (9). Used to display the Union Jack when moored or at anchor.
  - (j) Bow ramp controls (10). Bow ramp controller to raise or lower the bow ramp.
  - (k) Sound powered telephone (11).
  - (l) Escape hatch (12). Escape hatch for the bowthruster compartment.
  - (m) Bow anchor windlass controller (13). Controller to raise or lower bow anchor, one port and one starboard.
  - (n) Suez Canal light control (14). Controller for Suez Canal light.
  - (o) Foremast (15). Used to support navigational lights.

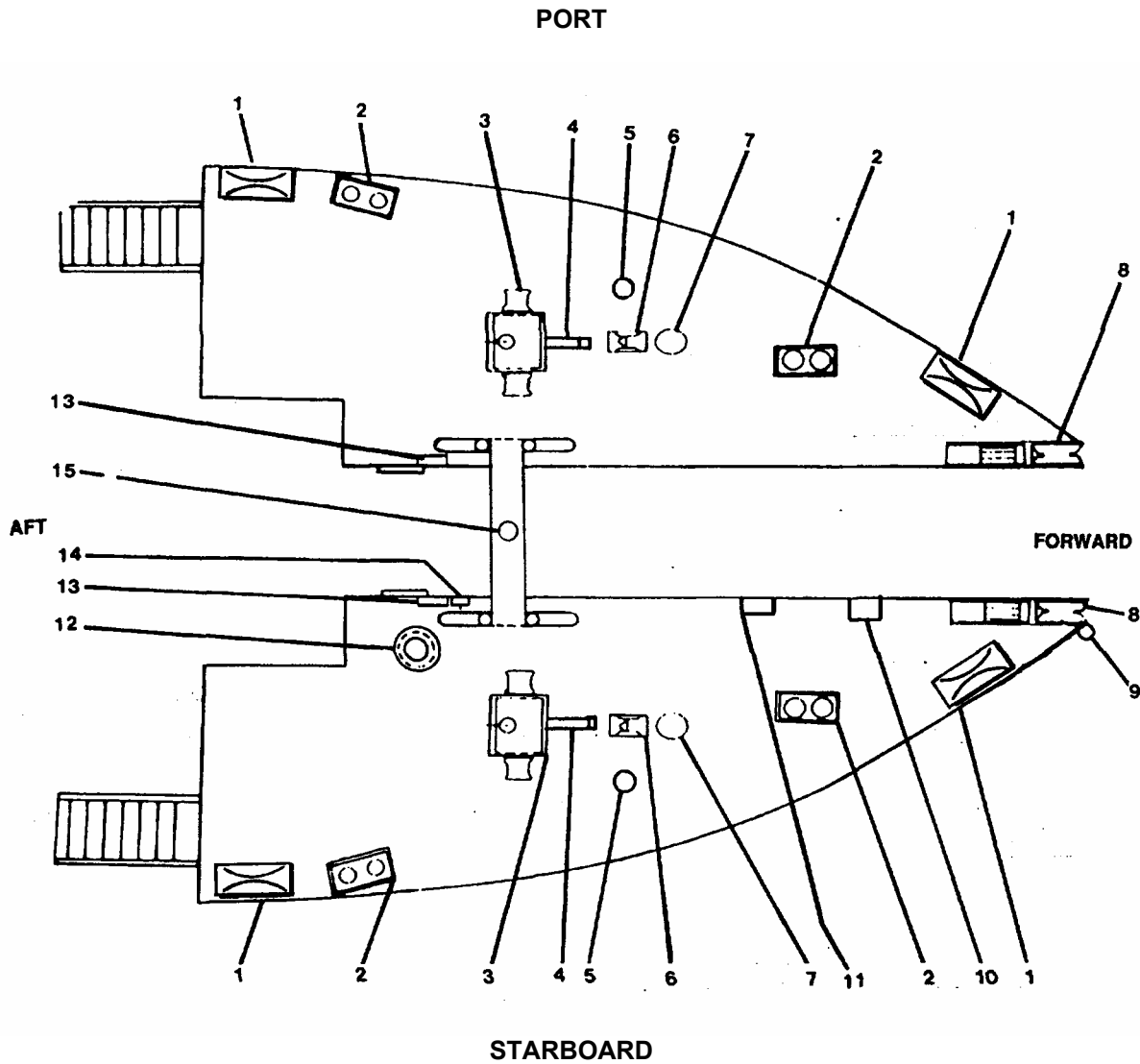

**LEGEND:**

- |  |  |
|--|--|
| <ul style="list-style-type: none"> <li>1. CLOSED CHOCK</li> <li>2. DOUBLE BITT</li> <li>3. BOW ANCHOR WINDLASS</li> <li>4. DEVIL'S CLAW</li> <li>5. FAIRLEAD ROLLER</li> <li>6. CHAIN STOPPER (BOW ANCHOR)</li> <li>7. HAWSEPIPE</li> <li>8. WILDCAT (BOW RAMP)</li> </ul> | <ul style="list-style-type: none"> <li>9. JACKSTAFF</li> <li>10. BOW RAMP CONTROLS</li> <li>11. SOUND POWERED TELEPHONE</li> <li>12. ESCAPE HATCH</li> <li>13. BOW ANCHOR WINDLASS CONTROLLER</li> <li>14. SUEZ CANAL LIGHT CONTROL</li> <li>15. FOREMAST</li> </ul> |
|--|--|

FIGURE 1-7. Forecastle Deck External Features.

c. LCU Internal Features. Refer to FIGURE 1-8 for a complete inboard profile of the LCU.

(1) Inboard profile.

- (a) 02 Level contains the pilothouse (2).
- (b) 01 Level contains crew staterooms (17), chief engineer's stateroom (3), and vessel master's stateroom (3).

**NOTE**

**Not applicable to vessels with FM-200 Fire Suppressant System installed. Reference paragraph 2-46 through 2-47, for FM-200 and Water Washdown System operation. Reference TM 55-1905-243-24&P, LCU-2000, FM-200 Fire Fighting System for maintenance and installation of FM-200 components.**

- (c) Main deck contains the mess/galley facilities (10), air conditioning and emergency generator room (15) and HALON stowage (16).
- (d) Below main deck contains seawater ballast (4), bowthruster area (5), tunnel (6), hydraulic oil tank (7), foam tank (8), dirty oil tank (9), engine operating station (11), lube oil tank (12), fuel oil day tanks (13) and steering gear compartment (14). Exhaust pipes go from the engine room up through the uptake (1) to the funnel.

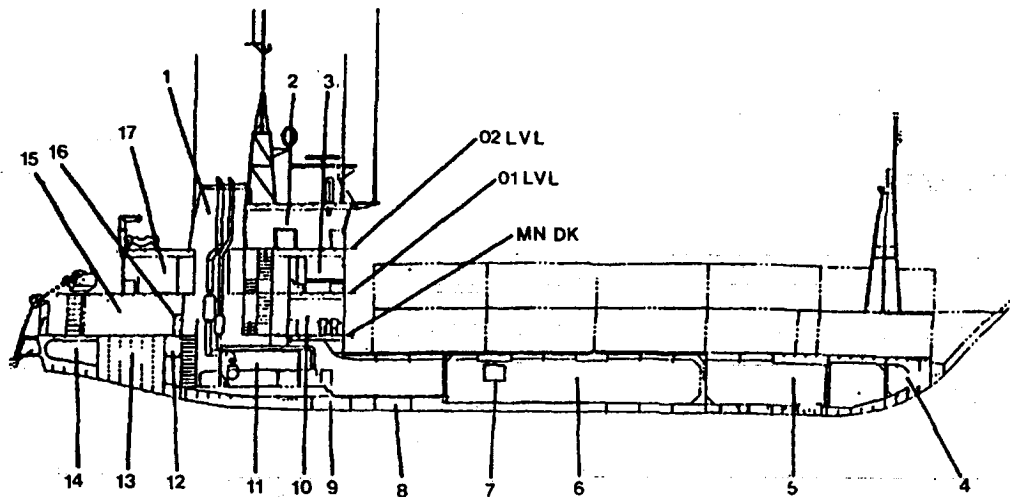

**LEGEND:**

- |   |   |
|---|---|
| <ul style="list-style-type: none"> <li>1. UPTAKESPACE</li> <li>2. PILOT HOUSE</li> <li>3. CHIEF ENGINEER'S STATEROOM (CENTERLINE)/ VESSEL MASTER'S STATEROOM (STARBOARD)</li> <li>4. SEAWATER BALLAST</li> <li>5. BOWTHRUSTER AREA</li> <li>6. TUNNEL</li> <li>7. HYDRAULIC OIL TANK</li> <li>8. FOAM TANK</li> </ul> | <ul style="list-style-type: none"> <li>9. DIRTY OIL TANK</li> <li>10. MESS/GALLEY FACILITIES</li> <li>11. ENGINE OPERATING STATION</li> <li>12. LUBE OIL TANK</li> <li>13. FUEL OIL DAY TANK</li> <li>14. STEERING GEAR COMPARTMENT</li> <li>15. AIR CONDITIONING &amp; EMERGENCY GENERATOR ROOM</li> <li>16. HALON STOWAGE</li> <li>17. CREWMEMBERSTATEROOM</li> </ul> |
|---|---|

FIGURE 1-8. LCU Inboard Profile.

(2) Pilothouse The pilothouse is the command center of the vessel.

(a) Pilothouse control console. Sheet 1, FIGURE 1-9 shows the equipment located in the control console.

- 1 Machinery plant monitor system (1). The machinery plant monitor system is a micro-computer that monitors important operating data for the main engines, main generator engines, and bowthruster engine. The system also monitors tank levels, fire main and control air pressure, ventilation fan condition, steering system, air conditioner seawater pump condition, freshwater system, lube oil system, dirty oil system, and other important conditions vital to the LCU's operation. The system provides display of operating data on a Cathode Ray Tube (CRT).
- 2 Autopilot (2). Autopilot provides automatic steering control.
- 3 Steering control panel (3). Provides means to select and indicate mode of operation and which steering pump is operating.
- 4 Bowthruster/fire pump throttle/clutch (4). Engages clutch and adjusts speed of the bowthruster diesel engine. When moved to the right, engages bow- thruster; when moved to the left, engages the fire pump.
- 5 Bowthruster control panel (5). Provides operation and directional control of the bowthruster waterjet set.
- 6 Engine order telegraph (6). The engine order telegraph (EOT) system communicates pilothouse directions to the engine room when the pilothouse is not in direct control of the main engines.
- 7 Depth finder digital display (7). The AN/SQN-21 Depth Finder Digital Display provides water depth information in feet or fathoms numerically on a four digit visual display.
- 8 Blinker light key (8). Telegraph type key used to send messages by blinker lights on the mast.
- 9 Bowthruster engine tachometer (9). Indicates revolutions per minute (RPM) of the bowthruster diesel engine.
- 10 Bow ramp control panel (10) Controls for raising and lowering the bow ramp.
- 11 Air pressure gauge (11). Air pressure gauge indicates control air pressure.
- 12 Control air valve (12). Valve to select control air from engine room (up) or give control air to engine room (down).
- 13 STBD shaft tachometer (13). Indicates RPM and direction of the starboard propeller shaft.

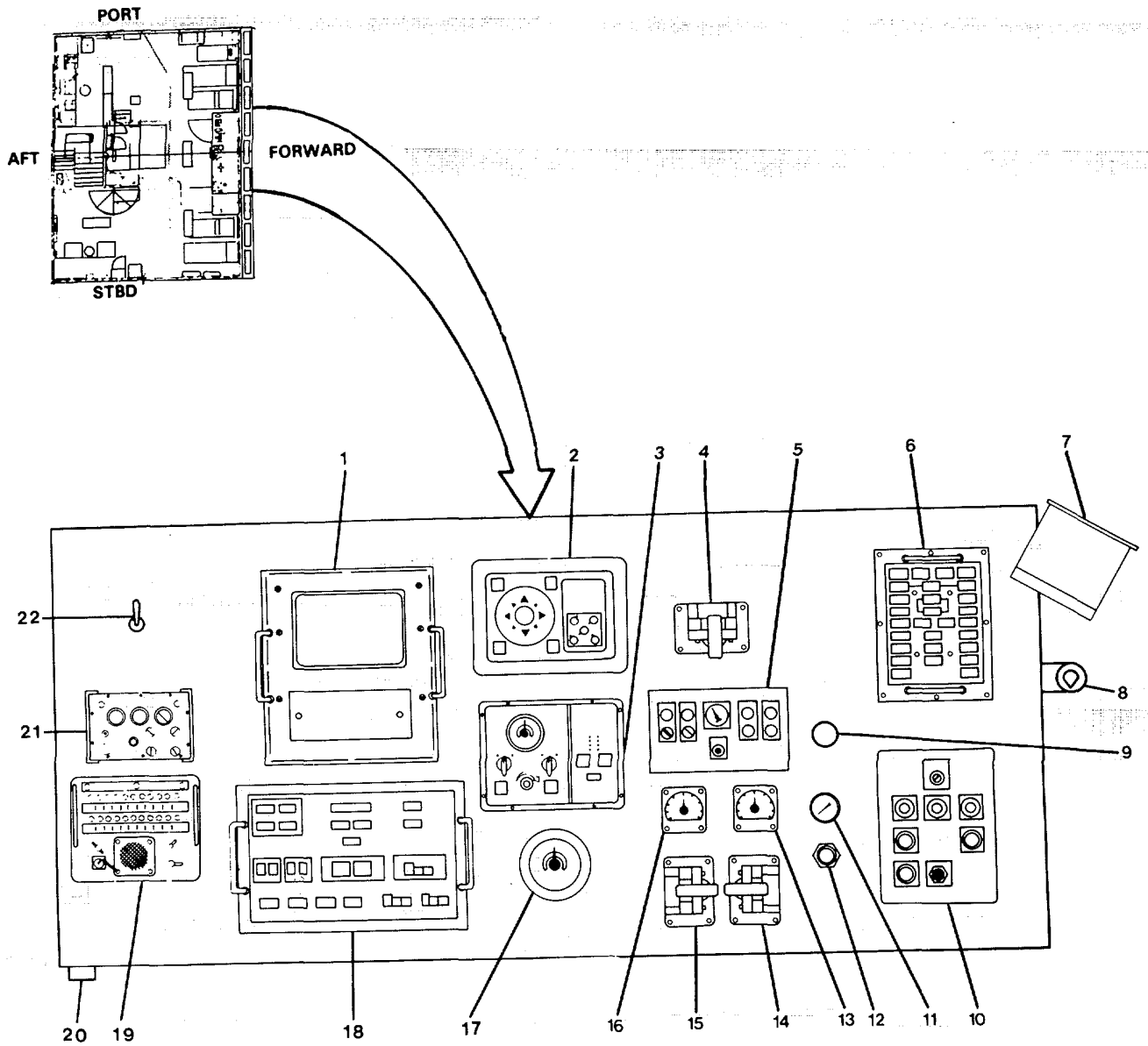

**LEGEND**

- |  |  |
|--|--|
| <ul style="list-style-type: none"> <li>1. MACHINERY PLANT MONITOR SYSTEM</li> <li>2. AUTOPILOT</li> <li>3. STEERING CONTROL PANEL</li> <li>4. BOWTHRUSTER/FIRE PUMP THROTTLE/CLUTCH</li> <li>5. BOWTHRUSTER CONTROL PANEL</li> <li>6. ENGINE ORDER TELEGRAPH</li> <li>7. DEPTH FINDER DIGITAL DISPLAY</li> <li>8. BLINKER LIGHT KEY</li> <li>9. BOWTHRUSTER ENGINE TACHOMETER</li> <li>10. BOW RAMP CONTROL PANEL</li> </ul> | <ul style="list-style-type: none"> <li>11. AIR PRESSURE GAUGE</li> <li>12. CONTROL AIR VALVE</li> <li>13. STBD SHAFT TACHOMETER</li> <li>14. STBD M.E. THROTTLE/CLUTCH</li> <li>15. PORT M.E. THROTTLE/CLUTCH</li> <li>16. PORT SHAFT TACHOMETER</li> <li>17. RUDDER ANGLE INDICATOR</li> <li>18. BRIDGE CONSOLE PANEL</li> <li>19. INTERCOM PANEL</li> <li>20. GENERAL ALARM CONTACT MAKER</li> <li>21. CONTROL UNIT FOR URC-80 RADIO</li> <li>22. POWER MODE SWITCH</li> </ul> |
|--|--|

FIGURE 1-9. Pilothouse (Sheet 1 of 9).



- 14 STBD M.E. throttle/clutch (14). Controls speed of the starboard main engine and engages the clutch of the starboard reduction gear for ahead or astern movement.
- 15 PORT M.E. throttle/clutch (15). Controls speed of the port main engine and engages the clutch of the port reduction gear for ahead or astern movement.
- 16 PORT shaft tachometer (16). Indicates RPM and direction of the port propeller shaft.
- 17 Rudder angle indicator (17). Indicator dial showing position of the rudder in relation to the center line of the LCU.
- 18 Bridge console panel (18). Control and indicator panel for steering, fire pumps, ventilation fans, heaters, air conditioners, main engines, and the CRT.
- 19 Intercom panel (19). Bridge control panel for ships intercommunications system (LS-519A/SIC(U)).
- 20 General alarm contact maker (20). Activates general alarm system.
- 21 Control unit for URC-80 radio (21). Control unit for radio set for short range ship-to-ship communications on the maritime service band telephone communication with the marine operator.
- 22 Power mode switch (22). Switch turns power ON or OFF to the URC-80 radio set.

(b) Pilothouse forward view. Sheet 2 of FIGURE 1-9 shows the equipment in including the ~~forward~~ section of the pilothouse.

- 1 Rotary window wiper (23). Heated circular clear screen rotates and the resulting centrifugal force cleans the glass to improve visibility.
- 2 Bulkhead mounting bracket with open scale steering gyro repeater (24). Contains gyro compass steering repeater. This repeater is driven by the ship's gyro compass, and has ON/OFF synchronizer control, dimmer switch, and manual synchronizer knob.
- 3 Magnetic compass periscope (25). Gives the helmsman ship's magnetic heading as displayed by the magnetic compass.
- 4 Fog horn switch (26). Three position switch controls the fog horn for automatic operation or on demand.
- 5 Depth finder digital display (27). The AN/SQN-21 Depth Finder Digit Display provides water depth information in feet or fathoms numerically on four digit visual display.
- 6 Searchlight lever/gear control (28). Twisting the handle raises or lowers the light; turning the handle from right to left directs the light in that direction. Light (Xenon 500W) is located on top of pilothouse.

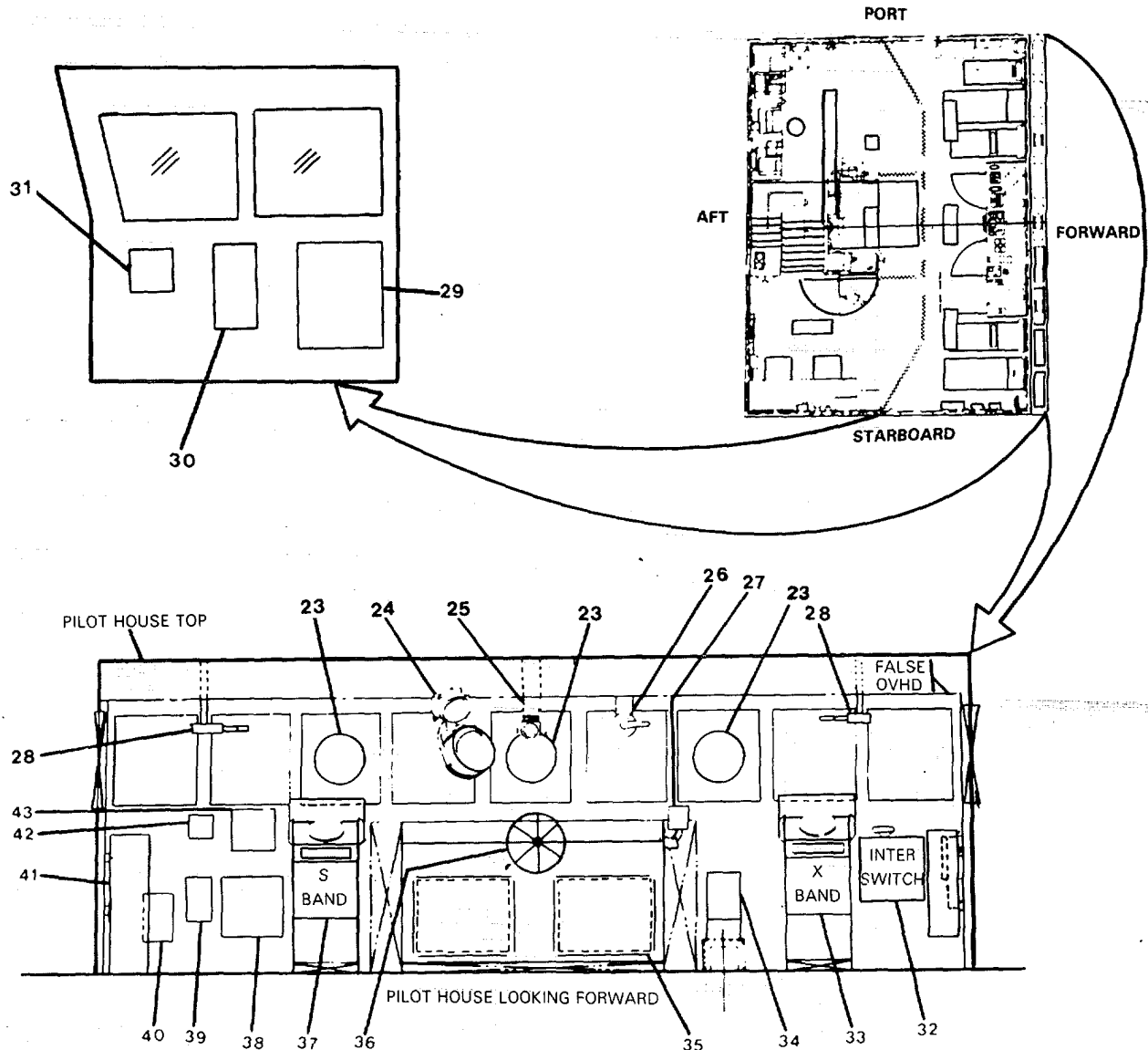

**LEGEND**

- |  |  |
|--|--|
| 23. ROTARY WINDOW WIPER  | 33. RADAR DISPLAY                      |
| 24. BULKHEAD MOUNTING BRACKET WITH OPEN SCALE STEERING GYRO REPEATER | 34. GYRO COMPASS                       |
| 25. MAGNETIC COMPASS PERISCOPE                                       | 35. PILOTHOUSE CONTROL CONSOLE CABINET |
| 26. FOG HORN SWITCH  | 36. HELM                               |
| 27. DEPTH FINDER DIGITAL DISPLAY                                     | 37. RADAR DISPLAY                      |
| 28. SEARCHLIGHT LEVER/GEAR CONTROL                                   | 38. GYRO COMPASS TRANSMISSION UNIT     |
| 29. MODULATOR TRANSMITTER/RECEIVER                                   | 39. POWER TRANSFER UNIT                |
| 30. RADAR DISTRIBUTION PANEL   | 40. EMERGENCY LIFEBOAT TRANSCEIVER     |
| 31. RADAR ISOLATION TRANSFORMER                                      | 41. MODULATOR TRANSMITTER/RECEIVER     |
| 32. RADAR INTERSWITCH  | 42. SWITCH UNIT                        |
|  | 43. POWER CONVERTER                    |

FIGURE 1-9. Pilothouse (Sheet 2 of 9).

- 7 Modulator transmitter/receiver (29). The Modulator Transmitter/Receiver (RT-1342B) transmits and receives radar signals at 50 kW in X band.
- 8 Radar distribution panel (30). Radar power distribution panel (SB- 4183/SPS-64(V)) receives power from Radar Isolation Transformer (31) and distributes to radar equipment.
- 9 Radar isolation transformer (31). The isolation/stepdown transformer unit stabilizes ship's power current to radar power supply.
- 10 Radar interswitch (32). Interswitch (SA-2308/SPS-64(V)) allows selection of either radar antenna for the 10 cm or 3 cm radar units.
- 11 Radar display (33). The Radar Display (IP-1469/SPS-64(V)16) provides azimuth range indicator with RAYPATH AUTOMATIC RADAR PILOTING AID (ARPA).
- 12 Gyro compass (34). Gyro Compass MK 27 MOD 1, located on the starboard side of pilothouse, indicates true ship's heading.
- 13 Pilothouse control console cabinet (35). Cabinet for the pilothouse console.
- 14 Helm (36). Rudder control wheel for follow-up mode steering.
- 15 Radar display (37). The Radar Display (IP-1469/SPS-64(V)17) provides azimuth range indicator with Raypath ARPA.
- 16 Gyro compass transmission unit (38). Transmission unit MK 37 MOD E provides gyro compass heading data to bearing repeaters, auto pilot, radars, omega equipment, and radio direction finding equipment.
- 17 Power transfer unit (39). Transfers 24 Vdc from power converter to gyro compass equipment. During loss of ship's service power, applies battery 24 Vdc to gyro compass equipment.
- 18 Emergency lifeboat transceiver (40). Emergency transceiver (403A) is to be utilized from a lifeboat. Transmits emergency distress signals and receives return signals. The unit is powered by a hand crank.
- 19 Modulator transmitter/receiver (41). The Modulator Transmitter/Receiver (RT-1241A) transmits and receives radar signals at 50kW in S Band.
- 20 Switch unit (42). Provides gyro compass heading data and 24 Vdc to open scale compass repeaters and the relay transmitter.
- 21 Power converter (43). Power converter MK 27 MOD 1 converts ship's service 120 Vac power to 24 Vdc and supplies the dc power to the Power Transfer Unit.

(c) Pilothouse aft view. Sheet 3 of FIGURE 1-9 shows the pilothouse looking aft.

- 1 Distress signal receiver (44). A radiotelephone distress frequency watebeiver (R-2414/SRQ) designed as an aid to safety of life at sea (SOLAS).
- 2 Pilothouse red lighting switch (45). Light switch to turn ON or OFF red lighting in the pilothouse.
- 3 Radiotelephone-alarm generator (46). The radiotelephone alarm generator (SG-1319/SCN) signals to the radiotelephone (RT-1600/U) which transmits the signals to alert listening stations of an emergency. Part of the SOLAS system.
- 4 Ship clinometer TYPE II-HEEL (47). A device (similar to a carpenter's level) that indicates by ~~m~~sea of a bubble in a tube of liquid, the amount of ship's roll or heel.
- 5 Plotting board, ship's status (48). Plotting board to display ship's status. Will be used as damage control center during exercise and at time ship has damage.
- 6 Navigation light panel (49). Controls navigation lights of the LCU.
- 7 Ship clinometer TYPE I-TRIM (50). Same as clinometer TYPE II-HEEL except that it indicates the amount of ship's pitch or trim.
- 8 Marine fire detection panel (51). Monitors selected compartments ~~fire~~ or smoke.
- 9 General alarm bell (52). Alerts pilothouse personnel when the general alarm is sounded.
- 10 Port searchlight power supply (53). Supplies required power for the port searchlight.
- 11 STBD searchlight power supply (54). Supplies required power for the starboard searchlight.
- 12 Power transformer for marine fire detection panel (55). Supplies required power for marine fire detection panel.
- 13 Fire alarm bell (56). Controlled by the fire detection panel to ring when an alarm condition is detected.
- 14 Telephone headset storage box (57). Storage container for the sound powered headset and chest set.
- 15 Alarm bell (58). Alarm bell for the arms control locker.
- 16 Alarm panel (59). Converts ac power to dc for the arms control locker alarm system.
- 17 Log table (60). Table for various record keeping.

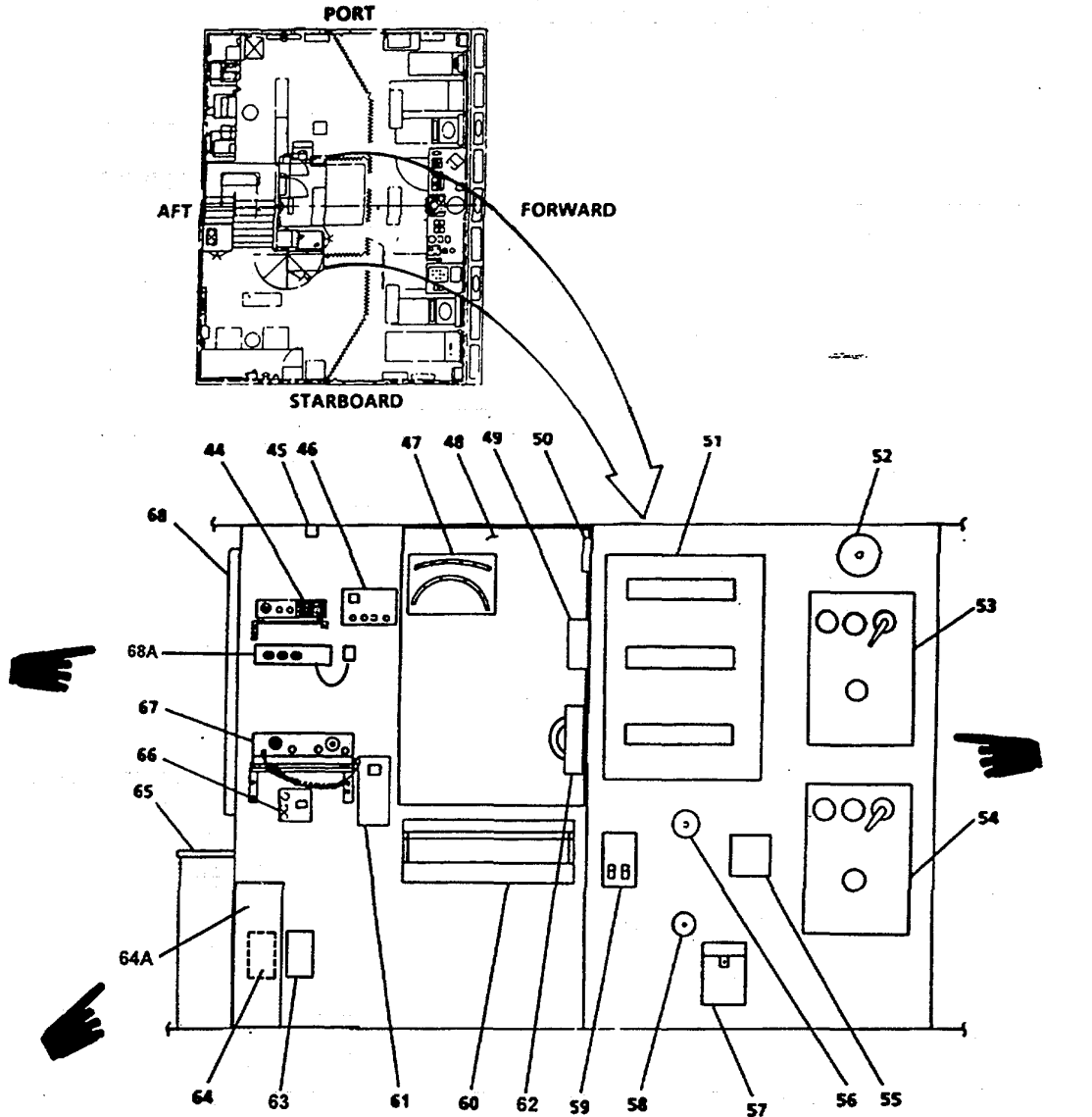

**LEGEND**

- |   |   |
|---|---|
| <ul style="list-style-type: none"> <li>44. DISTRESS SIGNAL RECEIVER</li> <li>45. PILOTHOUSE RED LIGHTING SWITCH</li> <li>46. RADIOTELEPHONE ALARM GENERATOR</li> <li>47. SHIP CLINOMETER TYPE II - HEEL</li> <li>48. PLOTTING BOARD, SHIPS STATUS</li> <li>49. NAVIGATION LIGHT PANEL</li> <li>50. SHIP CLINOMETER TYPE I - TRIM</li> <li>51. MARINE FIRE DETECTION PANEL</li> <li>52. GENERAL ALARM BELL</li> <li>53. PORT SEARCHLIGHT POWER SUPPLY</li> <li>54. STBD SEARCHLIGHT POWER SUPPLY</li> <li>55. POWER TRANSFORMER FOR MARINE FIRE DETECTION PANEL</li> <li>56. FIRE ALARM BELL</li> <li>57. TELEPHONE HEADSET STORAGE BOX</li> </ul> | <ul style="list-style-type: none"> <li>58. ALARM BELL</li> <li>59. ALARM PANEL</li> <li>60. LOG TABLE</li> <li>61. ANTENNA ARTIFICIAL ASSEMBLY</li> <li>62. SOUND POWERED TELEPHONE</li> <li>63. DC CONVERTER</li> <li>64. DC POWER SUPPLY (HIDDEN)</li> <li>64A. SIGNAL FLAG STORAGE CABINET</li> <li>65. CABINET</li> <li>66. AUTOMATIC POWER SWITCH</li> <li>67. RECEIVER/TRANSMITTER</li> <li>68. CHART CABINET</li> <li>68A. INTERCOM</li> </ul> |
|---|---|

FIGURE 1-9. Pilothouse (Sheet 3 of 9)

- 18 Antenna artificial assembly (61). Provides an artificial antenna for testing the RT-1600/U auxiliary radiotelephone.
- 19 Sound powered telephone (62). Used for ship's internal communication.
- 20 dc Converter (63). Converts ships 120 Vac to 24 Vdc and provides to the dc power supply (64)
- 21 dc Power supply (64). Receives power from dc converter (63) and provides it to the automatic power switch (66).
- 21A Signal flag storage cabinet (64A).
- 22 Cabinet (65). Cabinet for records and forms with writing area on top.
- 23 Automatic power switch (66). Panel to check the condition of the emergency battery.
- 24 Receiver/transmitter (67). Auxiliary radiotelephone (RT.-1600/U) for use in case of failure of the ship's main radio station.
- 25 Chart cabinet (68). Storage space for navigation charts.
- 26 Intercom (68A). Provides intercommunications to all areas of the craft.

(d) Pilothouse starboard aft. Sheet 4 of FIGURE 1-9 shows the pilothouse looking starboard aft.

- 1 Window (69). Five windows are on the starboard side of pilot house for visibility, with three in the starboard aft bulkhead.
- 2 Omega receiver (70). The Omega Receiver (AN/SRO-23) provides navigational information from the worldwide network of Omega transmitters.
- 3 Speed log display unit (71). Three digit display indicates speed of the LCD in knots. Two arrow-mark lamps indicate direction. Unit also has a distance counter.
- 4 Automatic direction finder (72). The automatic direction finder (AN/SRD-26) indicates the direction of received radio signals either from shore stations or other ships.
- 5 Chart table (73). Where navigator plots the LCU's course on charts.
- 6 Chronometer storage cabinet (74). Recessed cabinet with a glass top to view the ship's chronometer.
- 7 Storage cabinet (75). Contains two shelves for small item storage.
- 8 Chart storage (76). Large shallow drawers to store navigation charts flat.

- 9 Electrical Equipment Mounting Base MT-6486/SRN (77A). Provides a stable ~~platf~~ to mount the control indicator.
- 9A Indicator Control C-11702/UR (77B). Mounts in the electrical mounting base by eight quarter turn fasteners. Provides operator controls and displays.
- 9B Electrical Equipment Mounting Base MT-6586/S (77C). Provides a stable base to mount the radio receiver.
- 9C Radio Receiver R-2331/URN (77D). The radio receiver is the receiver processor for the AN/WRN-6(v). Three C-cell alkaline batteries, used to save memory contents when power is off, are located in a battery tray assembly on the front of the chassis.
- 10 Antenna coupler (78). Antenna coupler (Dymek DA 100D for the RD-605/UXH Facsimile Recorder-Reproducer.

**Change 6 1-28.1/(1-28.2 blank)**

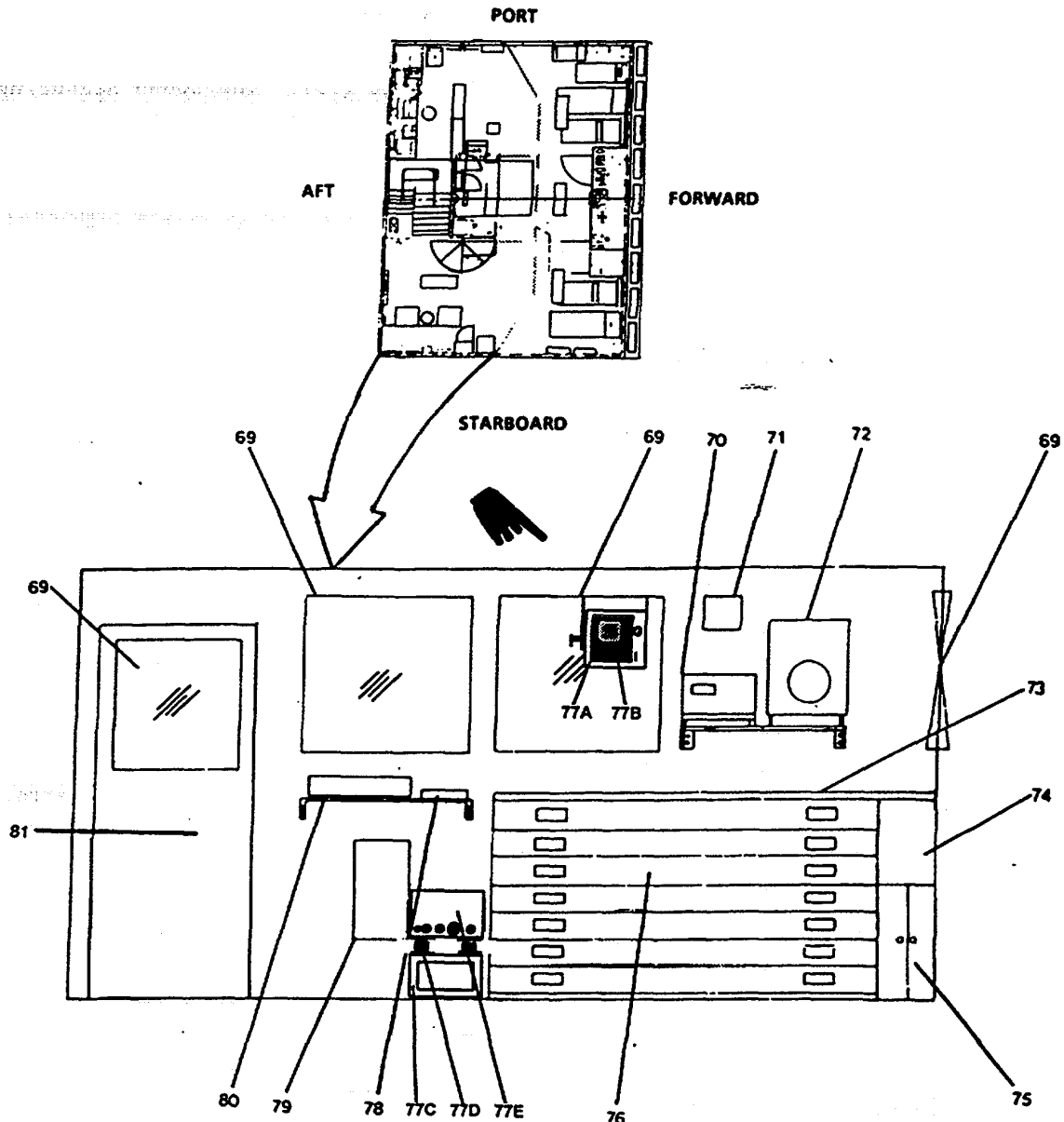

**LEGEND**

- |   |   |
|---|---|
| 69. WINDOW                              | 77B. INDICATOR CONTROL                        |
| 70. OMEGA RECEIVER                      | 77C. EQUIPMENT MOUNT                          |
| 71. SPEED LOG DISPLAY UNIT              | 77D. ELECTRICAL EQUIPMENT MOUNTING BASE       |
| 72. AUTOMATIC DIRECTION FINDER          | 77E. RADIO RECEIVER                           |
| 73. CHART TABLE                         | 78. ANTENNA COUPLER                           |
| 74. CHRONOMETER STORAGE CABINET         | 79. SOUND MEASURING SET MAIN ELECTRONICS UNIT |
| 75. STORAGE CABINET                     | 80. FACSIMILE RECORDER-REPRODUCER             |
| 76. CHART STORAGE                       | 81. DOOR                                      |
| 77A. ELECTRICAL EQUIPMENT MOUNTING BASE |   |

FIGURE 1-9. Pilothouse (Sheet 4 of 9).



- 11 Sound measuring set main electronics unit (79). The Sound Measuring Set (AN/SQN-20) generates and processes signals for the speed log display unit.
- 12 Facsimile recorder-reproducer (80). The Facsimile Recorder-Reproducer (RD-605/UXH) receives radio facsimile weather charts from 45 military and civilian transmission sites in over 25 countries.
- 13 Door (81). Starboard entrance/exit to the pilothouse.

(e) Pilothouse aft/starboard. Sheet 5 of FIGURE 1-9 shows the pilothouse looking aft/starboard.

- 1 Window (82). Three windows are on the aft of the pilothouse for visibility.
- 2 Certification displays (83). To display registration.
- 3 Fire extinguisher (84). Portable multi-use extinguisher.
- 4 Binocular storage box (85). Provides convenient storage for binoculars.
- 5 Arms control room sprinkler valve (86). Valve to turn on sprinklers located in the arms control room.
- 6 Survival suit storage (87). Storage for one survival suit.
- 7 Chart table (88). Where navigator plots the LCU's course on charts.

(f) Pilothouse looking aft/port. Sheet 6 of FIGURE 1-9 shows the pilothouse looking aft/port.

- 1 Windows (89). Two windows are on the aft of the pilothouse for visibility.
- 2 Army tactical receiver/transmitter (90). Army tactical receiver-transmitter (RT-524/VRC) for voice communications.
- 3 Interconnection box (91). The Interconnection Box (J-4243/U) provides interface between the AN/UGC-74, AN/SGC-14 Telegraph Terminal, R-2408/URC and T-1527/URC.
- 4 Two mounts and one power switch (92). Two mounts and one power switch for secure equipment.
- 5 Security container cabinet (93). Combination locked file cabinet.
- 6 Interface unit (94). The interface unit (J-4795/U) allows the AM-7387/URC HF power amplifier (99) to be driven by the radio transmitter T-1527/URC (95) or the AN/URC-92 radio set (103).
- 7 Radio receiver (95). The Radio Receiver (R-2408/URC) operates as a high frequency (HF) single side band (SSB) receiver.

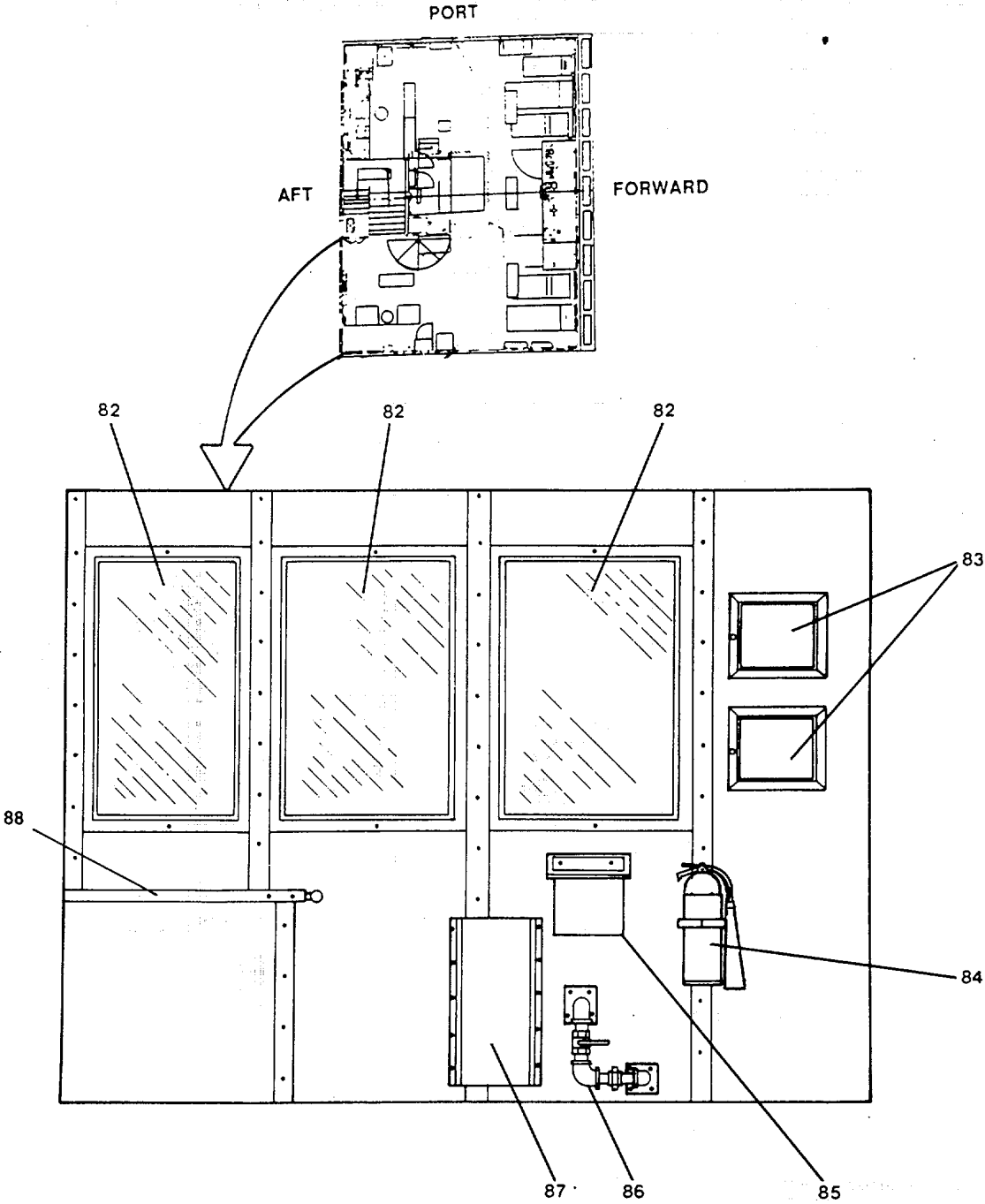

**LEGEND**

- 82. WINDOW
- 83. CERTIFICATION DISPLAY
- 84. FIRE EXTINGUISHER
- 85. BINOCULAR STORAGE BOX
- 86. ARMS CONTROL ROOM SPRINKLER VALVE
- 87. SURVIVAL SUIT STORAGE
- 88. CHART TABLE

FIGURE 1-9. Pilothouse (Sheet 5 of 9).

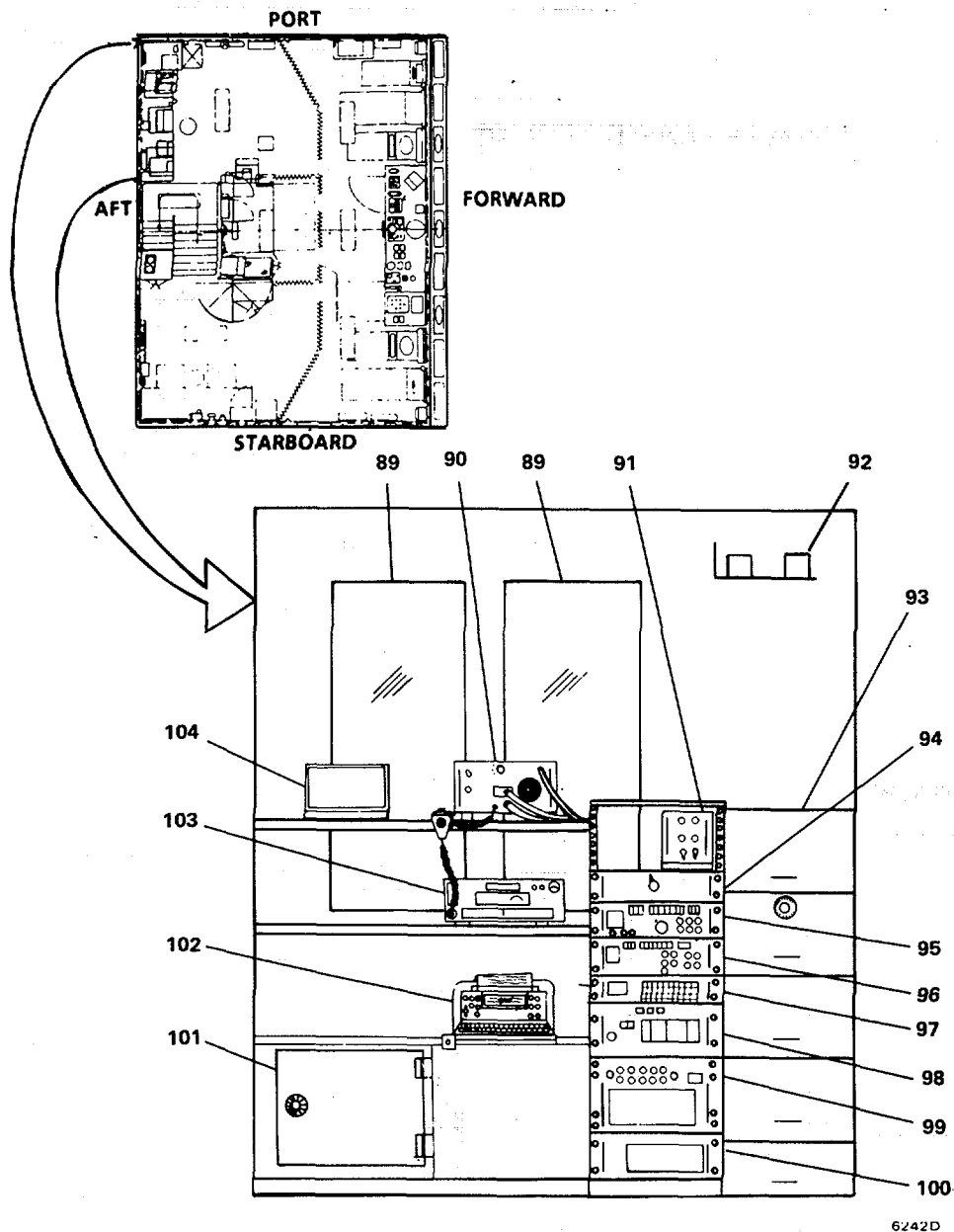

6242D

**LEGEND**

- |  |                               |
|--|-------------------------------|
| 89. WINDOW                             | 97. COMMUNICATIONS MODEM      |
| 90. ARMY TACTICAL RECEIVER/TRANSMITTER | 98. TELEGRAPH TERMINAL        |
| 91. INTERCONNECTION BOX                | 99. RADIO FREQUENCY AMPLIFIER |
| 92. 2 MOUNTS AND 1 POWER SWITCH        | 100. POWER SUPPLY             |
| 93. SECURITY CONTAINER CABINET         | 101. SAFE                     |
| 94. INTERFACE UNIT                     | 102. TELETYPE                 |
| 95. RADIO RECEIVER                     | 103. RADIO SET                |
| 96. RADIO TRANSMITTER                  | 104. RECEIVER/TRANSMITTER     |

FIGURE 1-9. Pilothouse (Sheet 6 of 9).

- 8 Radio transmitter (96). The Radio Transmitter (T-1527/URC) serves as a driver for the AM-7387/URC HF power amplifier (99).
- 9 Communications modem (97). The Communication Modem (MD-1255/URC) is a one or two channel modulator, or a one or two channel demodulator.
- 10 Telegraph terminal (98). The Telegraph Terminal (AN/SGC-14) provides direct printing telegraph service over HF radio in the Marine Mobile Service (MMS).
- 11 Radio frequency amplifier (99). The Radio Frequency Amplifier (AM-7387/URC) is used with the AN/URC-92 radio set (96) to boost the output power.
- 12 Power supply (100). The Power Supply (PP-8236/URC) for the AM-7387/URC HF power amplifier (99).
- 13 Safe (101). Combination safe for classified documents.
- 14 Teletype (102). Communications Terminal (AN/UGC-74B(V)3) is a terminal for teletype traffic.
- 15 Radio set (103). The Radio set (AN/URC-92) is used for voice communication.
- 16 Receiver/transmitter (104). The Identification Friend or Foe (IFF) transponder (AN/APX-72) operates with other IFF equipment.

(g) Pilothouse communications area looking forward. Sheet 7 of FIGURE 1-9 shows the forward bulkhead of the communications area.

- 1 EP 103 (105). Emergency power distribution for communications and electronic equipment.
- 2 L105 (106). Lighting panel for the wheelhouse.
- 3 Transformer (107). Isolation transformer for the 1 kW amplifier.
- 4 Ship's whistle power supply (108). Electrical power supply for the ship's horn.
- 5 Fog signal controller (109). Electrical control (24 Vdc) for the fog signal.
- 6 Signal timer (110). Electrical timer for the fog signal.

(h) Pilothouse communications area looking starboard. Sheet 8, FIGURE 1-9 shows the starboard bulkhead of the communications area.

- 1 EL102-(111). Emergency lighting panel for emergency lighting and required electronic equipment.
- 2 Type D-33A (112). 24V AC for the secure communication equipment rack.
- 3 Radio holder (113). Holder for recharging AN/PRC-129 radios.

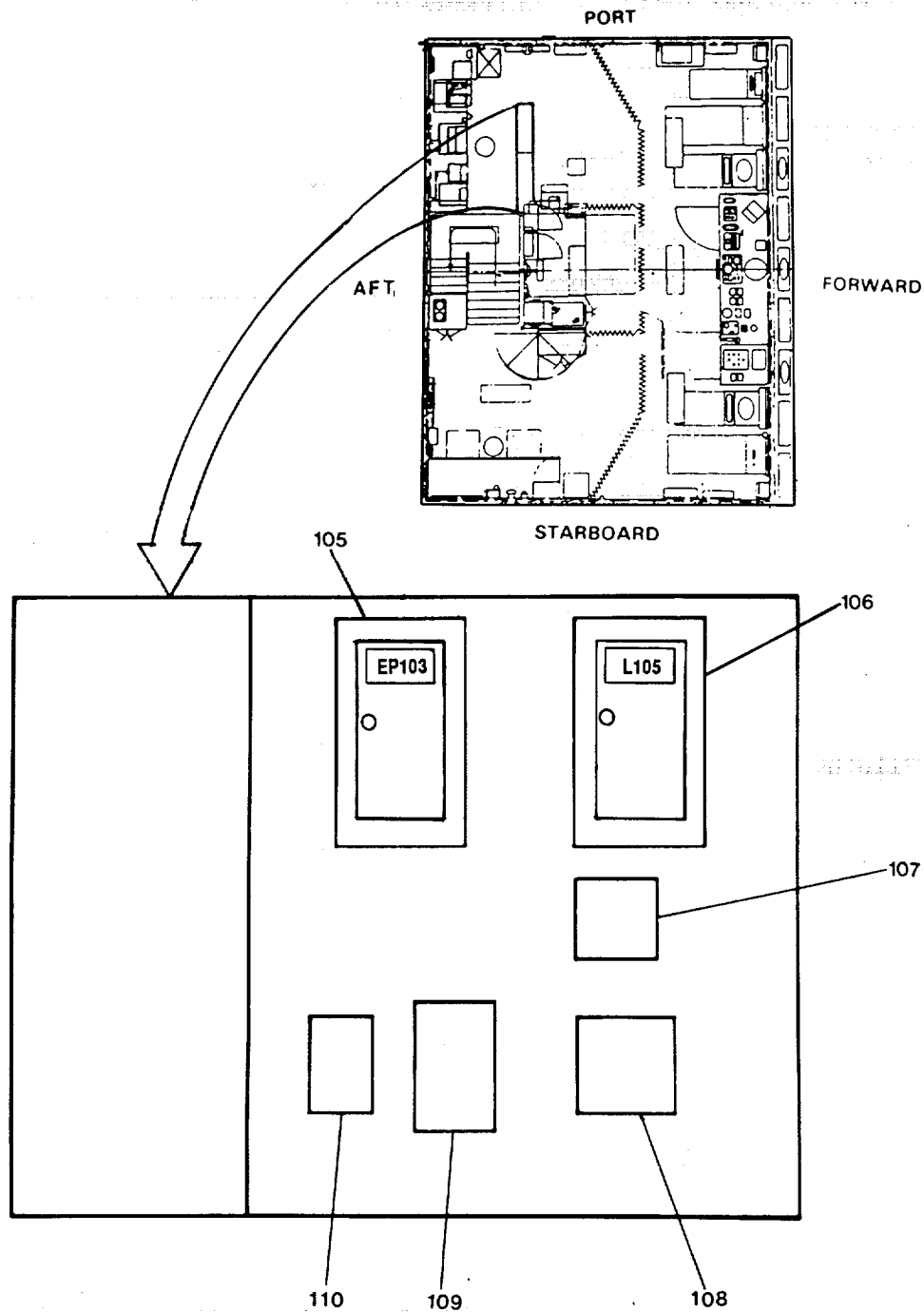

**LEGEND**

105. EP 103

106. L105

107. TRANSFORMER

108. SHIP'S WHISTLE POWER SUPPLY

109. FOG SIGNAL CONTROLLER

110. SIGNAL TIMER

FIGURE 1-9. Pilothouse (Sheet 7 of 9).

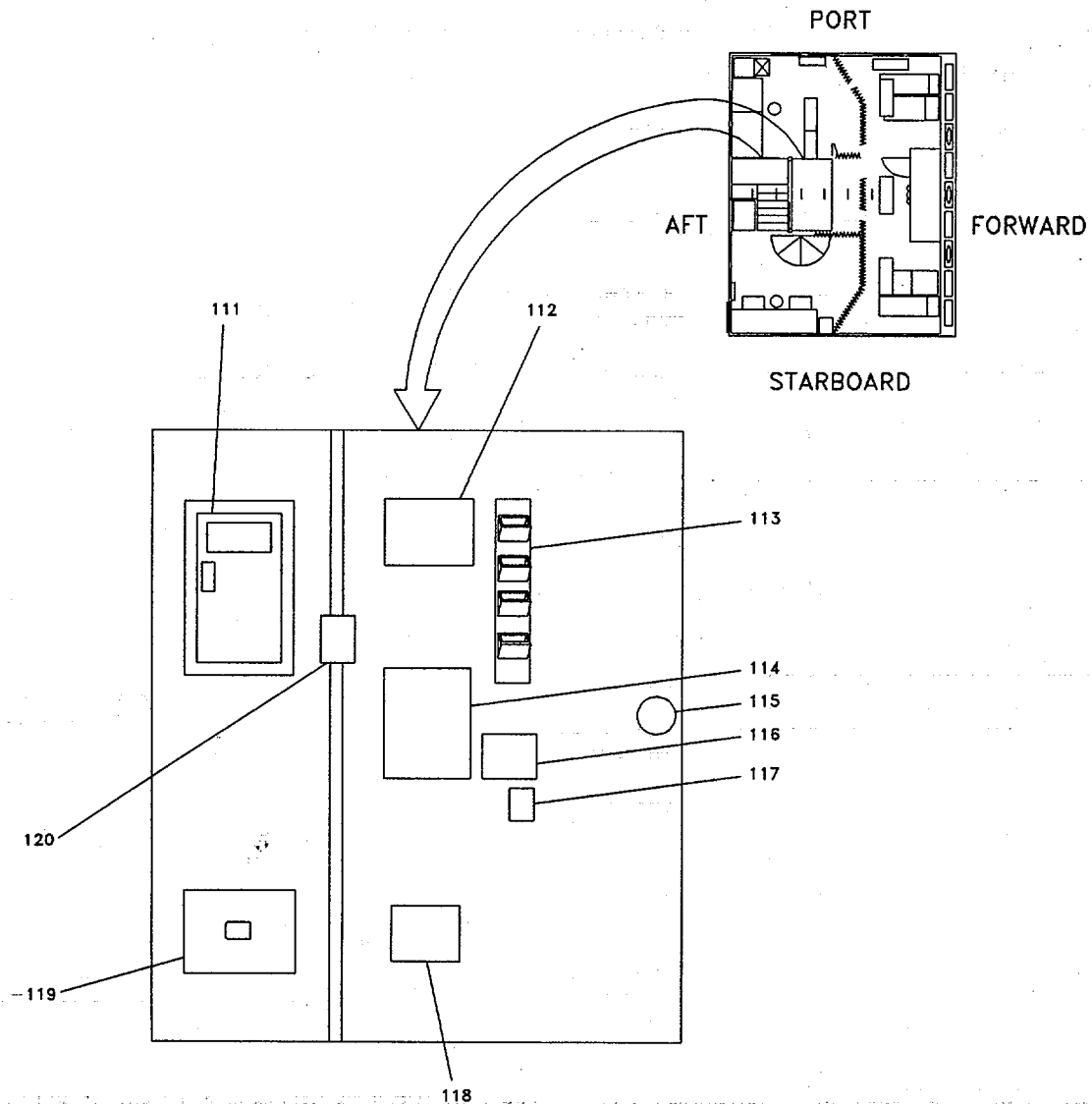

**LEGEND**

- |                          |                               |
|--------------------------|-------------------------------|
| 111. EL102               | 117. RESET SWITCH             |
| 112. TYPE D-33A          | 118. JUNCTION BOX             |
| 113. RADIO HOLDER        | 119. 24V BATTERY CHARGER      |
| 114. TYPE D-33A          | 120. SWITCH FOR SPEECH SECURE |
| 115. SWITCH              | EQUIPMENT                     |
| 116. BATTERY CHARGER FOR |                               |
| AN/PRC-129 RADIOS        |                               |

FIGURE 1-9. Pilothouse (Sheet 8 of 9).

- 4 TYPE D-33A (114). Fuse 24V distribution for secure communications rack.
- 5 Switch (115). Controls 24V power to the PP-8236/URC.
- 6 Battery Charger for AN/PRC-129 radios (116). Battery charger for the AN/PRC-129 radio holder.
- 7 Reset switch (117). Momentary switch to reset the Army tactical radio (AN/URC-46).
- 8 Junction box (118). Fused distribution box for the 24 Vdc systems.
- 9 24V Battery charger (119). 24 Vdc battery charger for the 24Vdc communications systems.
- 10 Switch for speech secure equipment (120). Switch to turn on secure speech equipment.

(i) Pilothouse communications area looking port. Sheet 9, FIGURE 1-9 shows the port bulkhead of the communications area.

- 1 Windows(121). Two windows provide visibility to the port side.
- 2 Coffee pot (122).
- 3 Water fountain (123). Provides potable water.
- 4 Storage cabinet (124).
- 5 Survival suit stowage (125). Provides storage for one survival suit.

(3)01 Level The internal features of this level include living quarters for the crew, the damage control locker, and laundry room as shown in FIGURE 1-10.

- (a) Four crew member stateroom (1). Contains living accommodations for four crew members including two double life jack containers, and four survival suit containers.
- (b) Three crew member stateroom (2) (Except LCU 2008, 9, 10, 11, 12). Contains living accommodations for crew members including one single life jack container. One double life jack container. The three survival suit containers are located on the passageway bulkhead just outside the door.
- (b.1) Four crew member stateroom (2) (LCU 2008, 9, 10, 11, 12 only). Contains living accommodations for three crew members, and an additional berth for a fourth crew member, includes two single life jacket containers, one double life jacket container. The four survival suit containers are located on the passageway bulkhead just outside the door.
- (c) Two crew member staterooms (3). Contains living accommodations for two crew members including one double life jacket container. Two survival suit containers are located on the passageway bulkhead just outside the door.
- (d) Chief Engineer's stateroom (4). Contains living accommodations for the Chief Engineer including one double life jacket container, sound powered telephone, safe, survival suit, intercom and Engineer Assistance Needed Alarm.

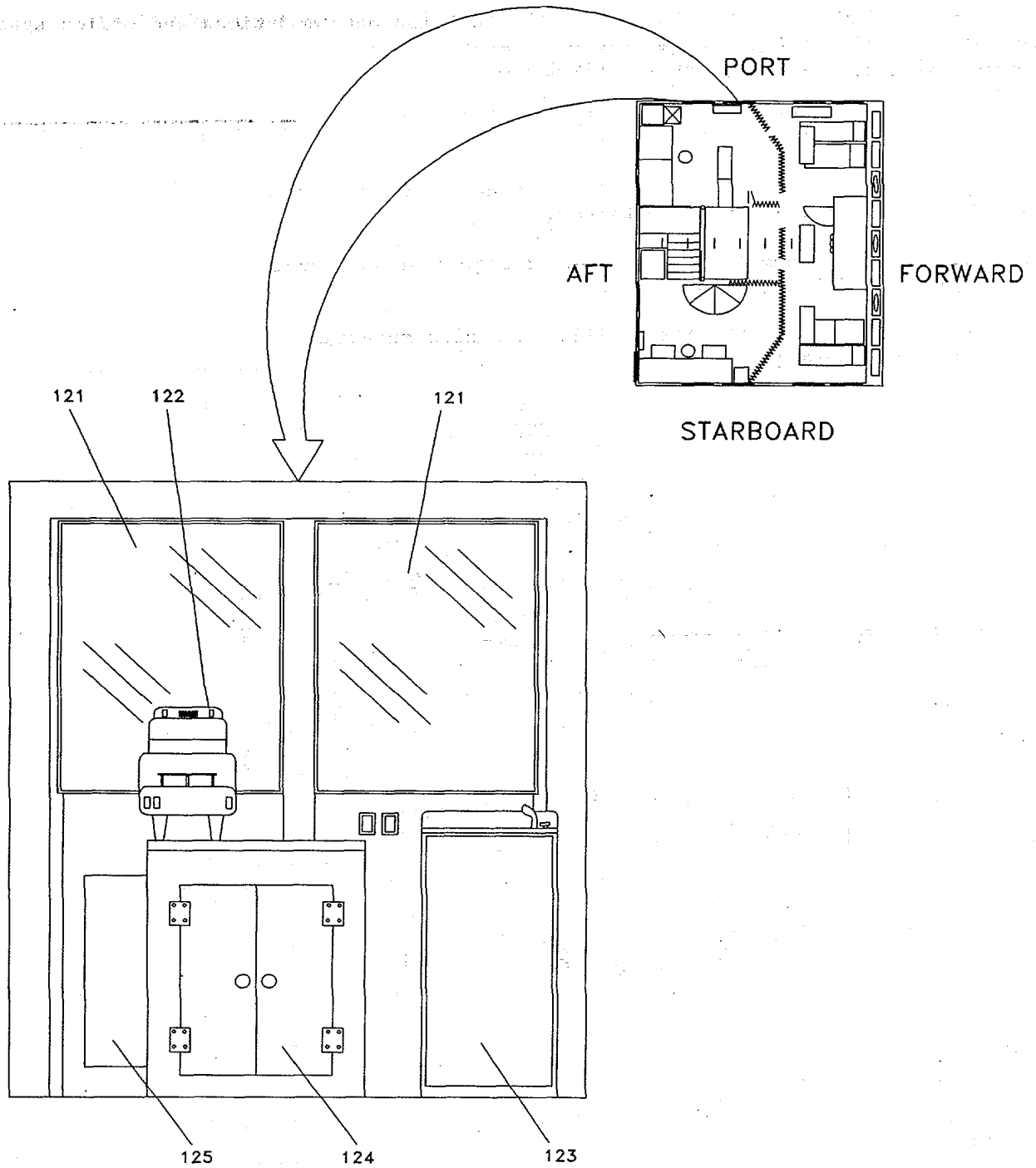

**LEGEND**

- 121. WINDOW
- 122. COFFEE POT
- 123. WATER FOUNTAIN
- 124. STORAGE CABINET
- 125. SURVIVAL SUIT STORAGE

FIGURE 1-9. Pilothouse (Sheet 9 of 9).



- (e) Officer's sanitary space (5). Contains a commode, a sink, a shower, and a space heater.
- (f) Vessel Master's stateroom (9). Contains accommodations and office space for the Vessel Master including key cabinet, sound powered telephone (6), intercom (7), telephone bell (8), safe (10), and survival suit.
- (g) Single sanitary space (12). Contains one commode, one sink, one shower, and a space heater (11).
- (h) Multiple sanitary space (13). Contains three commodes, three sinks, three showers, three urinals, and a space heater.
- (i) Laundry room (14). Contains storage cabinet, double sink, clothes washer, clothes dryer, and folding ironing board.
- (j) Damage control locker (15). Contains materials for damage repairs and a sound powered telephone (6).

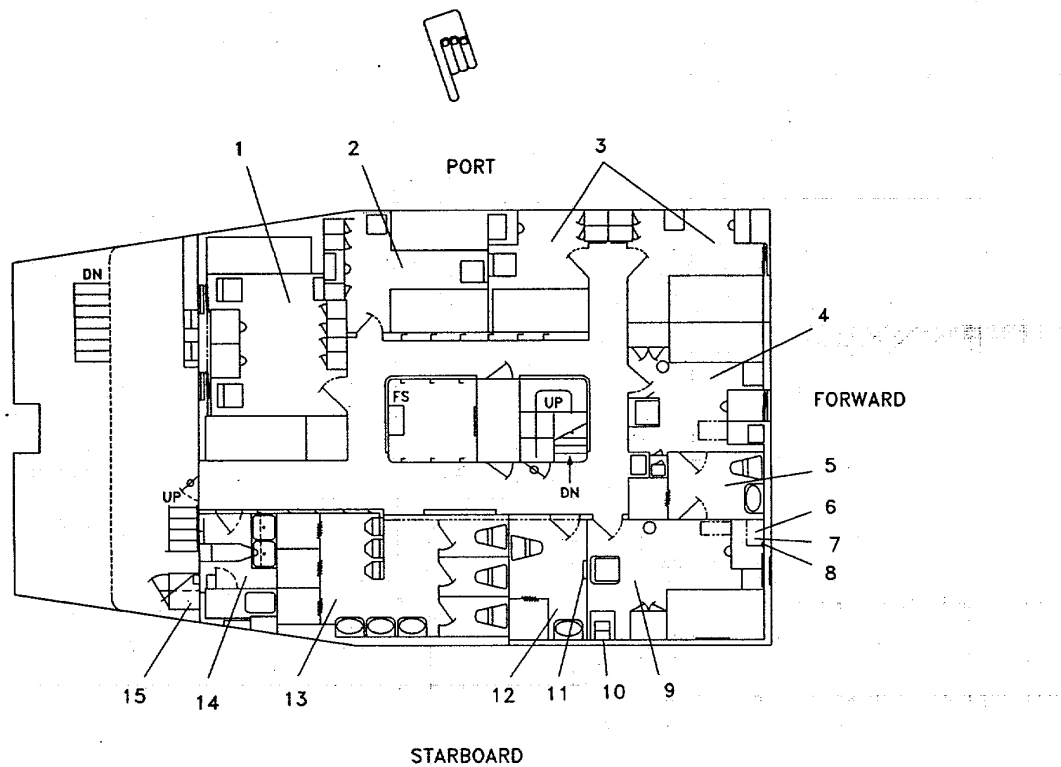

LEGEND

- |   |   |
|---|---|
| <ul style="list-style-type: none"> <li>1. (4) CREW SR</li> <li>2. (3) CREW SR *</li> <li>3. (2) CREW SR</li> <li>4. CHIEF ENGINEER SR</li> <li>5. OFFICER'S SANITARY SPACE</li> <li>6. SOUND POWERED TELEPHONE</li> <li>7. INTERCOM</li> <li>8. TELEPHONE BELL</li> <li>9. MASTER SR</li> <li>10. SAFE</li> </ul> | <ul style="list-style-type: none"> <li>11. SPACE HEATER</li> <li>12. SINGLE SANITARY SPACE</li> <li>13. MULTIPLE SANITARY SPACE</li> <li>14. LAUNDRY ROOM</li> <li>15. DAMAGE CONTROL LOCKER</li> </ul> |
|---|---|
- \* (4) CREW SR ON LCU 2008, 9 10, 11, 12 ONLY.

FIGURE 1-10. 01 Level.

(4) Main Deck. FIGURE 1-11 shows the compartments and internal features of the aft section of the main deck. Internal features include the provisions storeroom (1), galley (2), mess deck (3), recreation room (4), engine room operating station escape scuttle (5), foul weather gear locker (6) (also contains Gaylord Hodd pump, valves, booster heater and power panel), sick bay and toilet area (7), engine room HALON, fuel oil, lube oil and engine room ventilation manual controls (8), arms control room (9) and air conditioning and emergency generator room (10).

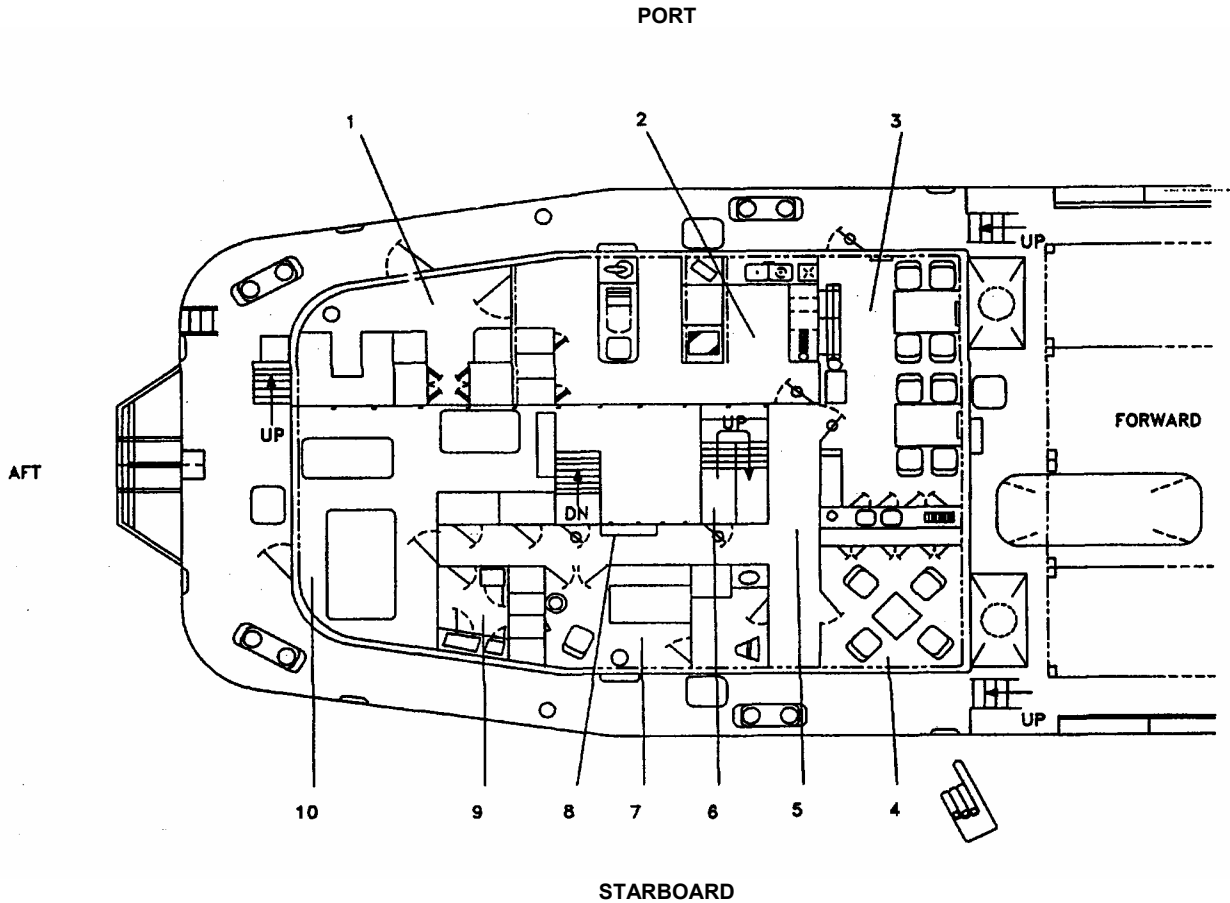

**LEGEND:**

- 1. PROVISIONS STOREROOM
- 2. GALLEY
- 3. MESS DECK
- 4. RECREATION ROOM \*
- 5. ENGINE ROOM OPERATING STATION ESCAPE SCUTTLE
- 6. FOUL WEATHER GEAR LOCKER
- 7. SICK BAY AND TOILET AREA

\*(3) CREW SR ON LCU 2008, 9, 10, 11, 12 ONLY.  
SEE FIGURE 1-15 FOR DETAIL

**NOTE**

No. 8 not applicable to vessels w/FM 200 Fire Suppressant System installed.

- 8. ENGINE ROOM HALON, FUEL OIL, AND LUBE OIL, AND ENGINE ROOM VENTILATION MANUAL CONTROLS
- 9. ARMS CONTROL ROOM
- 10. AIR CONDITIONING AND EMERGENCY GENERATOR ROOM

FIGURE 1-11. Compartments of the Aft Section of the Main Deck.

- (a) Provisions storeroom. The provisions storeroom (FIGURE 1-12) contains fire pull boy (1), watertight door (2), CO<sup>2</sup> fire extinguisher (3), duct heater controller (4), shelves (5), work table (6), shelf (7), safe (8), switch (9) (controls power for refrigerator), refrigerator (10), freezer (11), switch (12) (controls power for freezer) and bins (13).

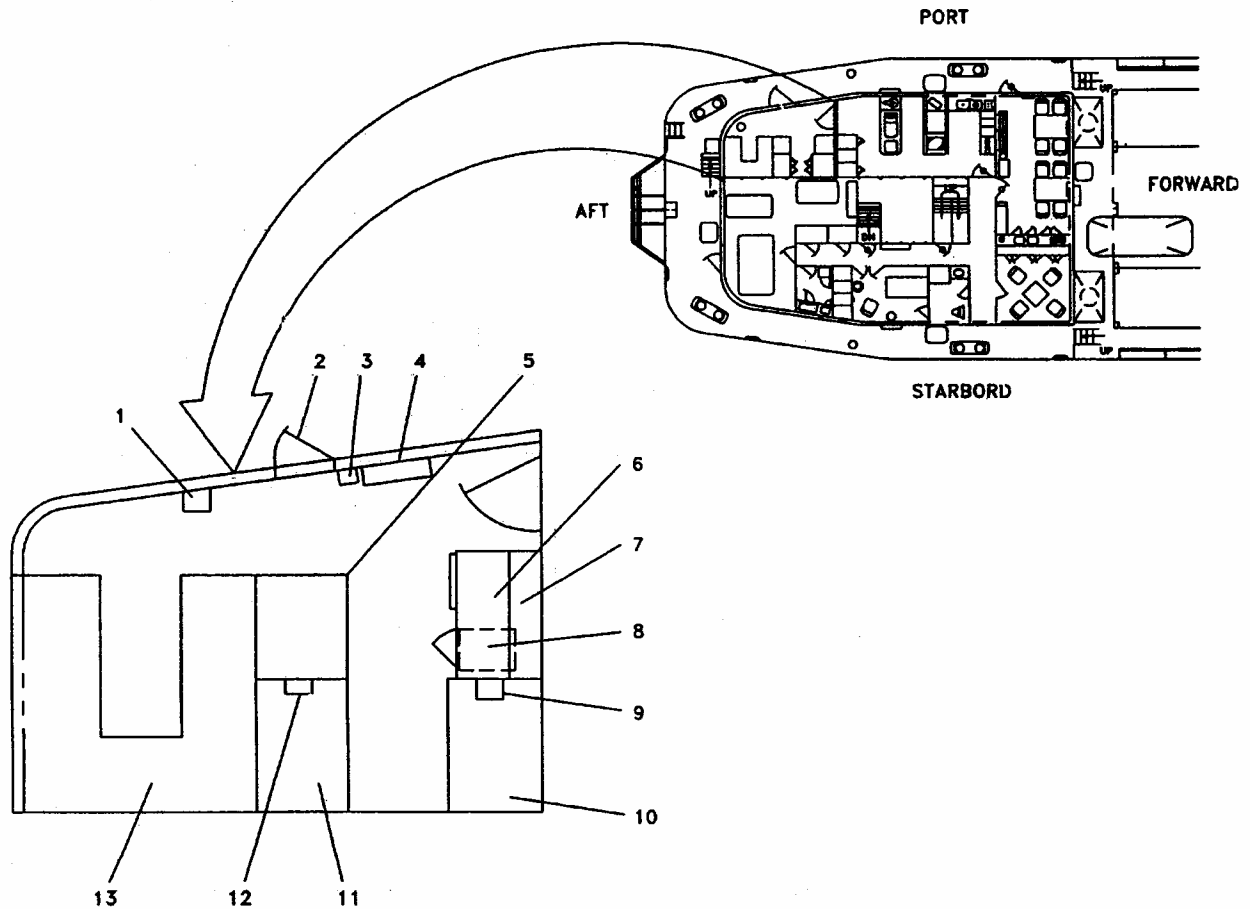

**LEGEND:**

- |                                      |                            |
|--------------------------------------|----------------------------|
| 1. FIRE PULL BOX                     | 8. SAFE (UNDER WORK TABLE) |
| 2. WATERTIGHT DOOR                   | 9. SWITCH                  |
| 3. CO <sup>2</sup> FIRE EXTINGUISHER | 10. REFRIGERATOR           |
| 4. DUCT HEATER CONTROLLER            | 11. FREEZER                |
| 5. SHELVES                           | 12. SWITCH                 |
| 6. WORK TABLE                        | 13. BINS                   |
| 7. SHELF (OVER)                      |                            |

FIGURE 1-12. Provisions Storeroom.

(b) Galley. The galley is shown in FIGURE 1-13. Equipment located in the galley includes: meat slicer (1); pot rack (2); mixer (3); knife sharpener (4); storage bins (5); knife rack (6); range (7); deep fat fryer (8); griddle (9); hood for range (10); sink (11); spray unit (12); garbage disposal (13); two pass through windows, one small (14) and one large (18); shelf with microwave oven (15); trash compactor (16); automatic dishwasher (17); toaster (19); coffee urn (20); storage cabinets (21); fire pull box (22); portable fire extinguisher (23); three motor controllers (24, 25, and 26) for ventilation fans; Gaylord control cabinet (27); sound powered telephone (28); cutting board (29); grease trap (32); refrigerator (33); work table (34); and freezer (35). Power panel P202 (30) provides 240 Vac distribution for the galley. Power panel P106 (31) provides 120 Vac distribution for the galley.

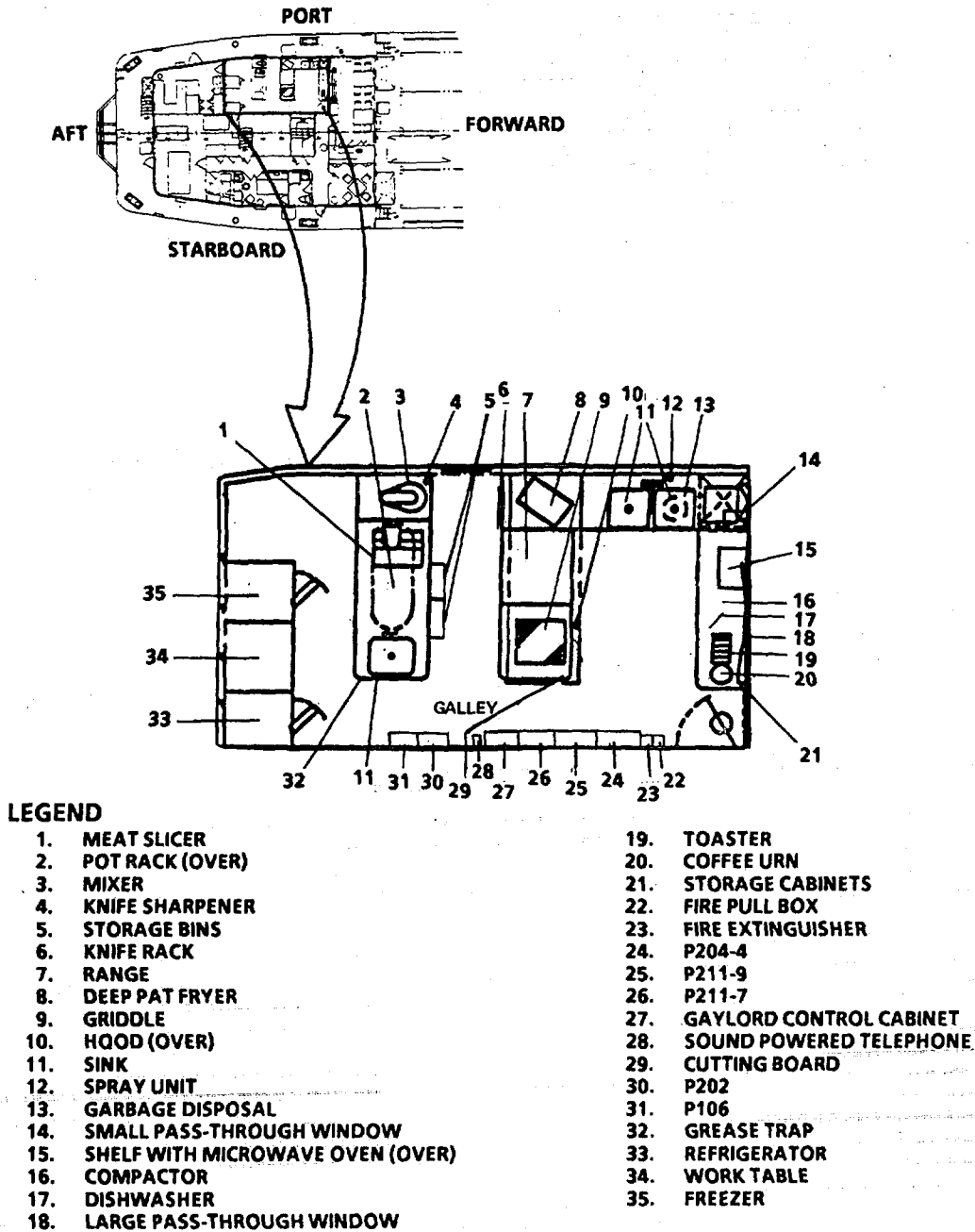
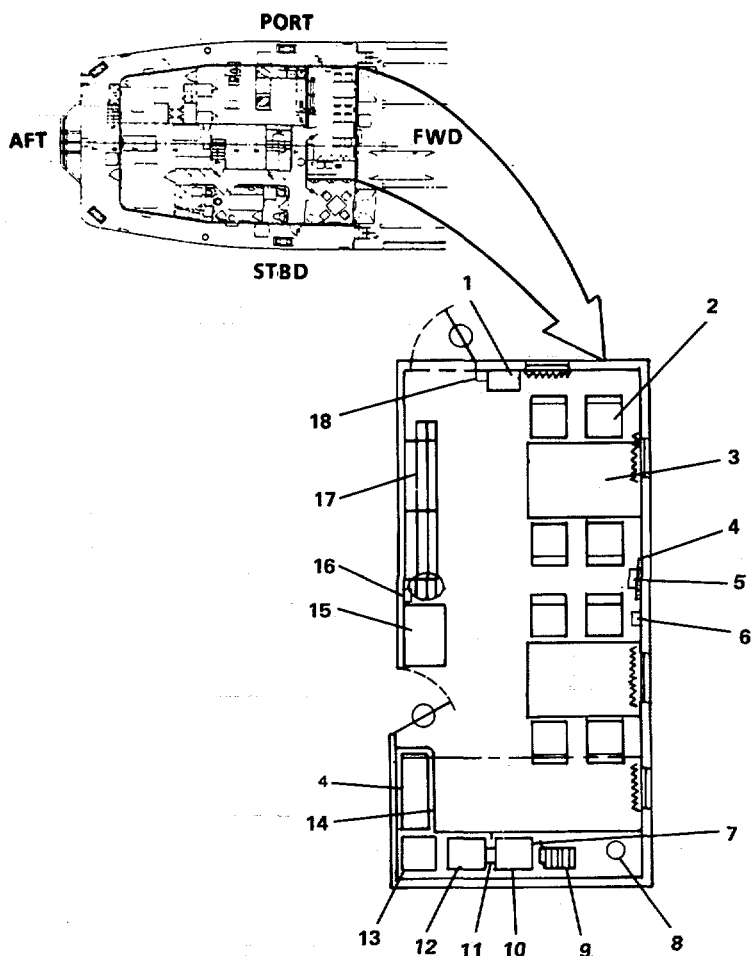

FIGURE 1-13. Galley.

(c) Mess deck. The mess deck is shown in FIGURE 1-14. The equipment in the mess deck includes water fountain (1), chairs (2), mess table (3), bulletin board (4), clock (5), intercom (6), an under-counter refrigerator (7), coffee maker (8), toaster (9), milk dispenser (10), carbonated bottle storage (11), carbonated beverage dispenser (post-mix dispenser) (12), icemaker (13), cups and glasses (14), trays and utensils storage (15), Engineer Assistance Needed Alarm (16), tray rail (17), and fire pull box (18).



**LEGEND**

- |   |  |
|---|--|
| <ul style="list-style-type: none"> <li>1. WATER FOUNTAIN</li> <li>2. CHAIRS</li> <li>3. MESS TABLE</li> <li>4. BULLETIN BOARD</li> <li>5. CLOCK</li> <li>6. INTERCOM</li> <li>7. REFRIGERATOR (UNDER)</li> <li>8. COFFEE MAKER</li> <li>9. TOASTER</li> </ul> | <ul style="list-style-type: none"> <li>10. MILK DISPENSER</li> <li>11. CARBONATED BEVERAGE STOWAGE (UNDER)</li> <li>12. CARBONATED BEVERAGE DISPENSER</li> <li>13. ICEMAKER</li> <li>14. CUPS &amp; GLASSES</li> <li>15. TRAYS &amp; UTENSILS</li> <li>16. ENGINEER ASSISTANCE NEEDED ALARM</li> <li>17. TRAY RAIL</li> <li>18. FIRE PULL BOX</li> </ul> |
|---|--|

FIGURE 1-14. Mess Deck.

(d) Recreation room. The recreation room, FIGURE 1-15, includes a bookcase (1), TV and VCR (2), chairs (3), card table (4), clock (5), waste basket (6), LS-519A Intercom (7), and bulletin board (8).

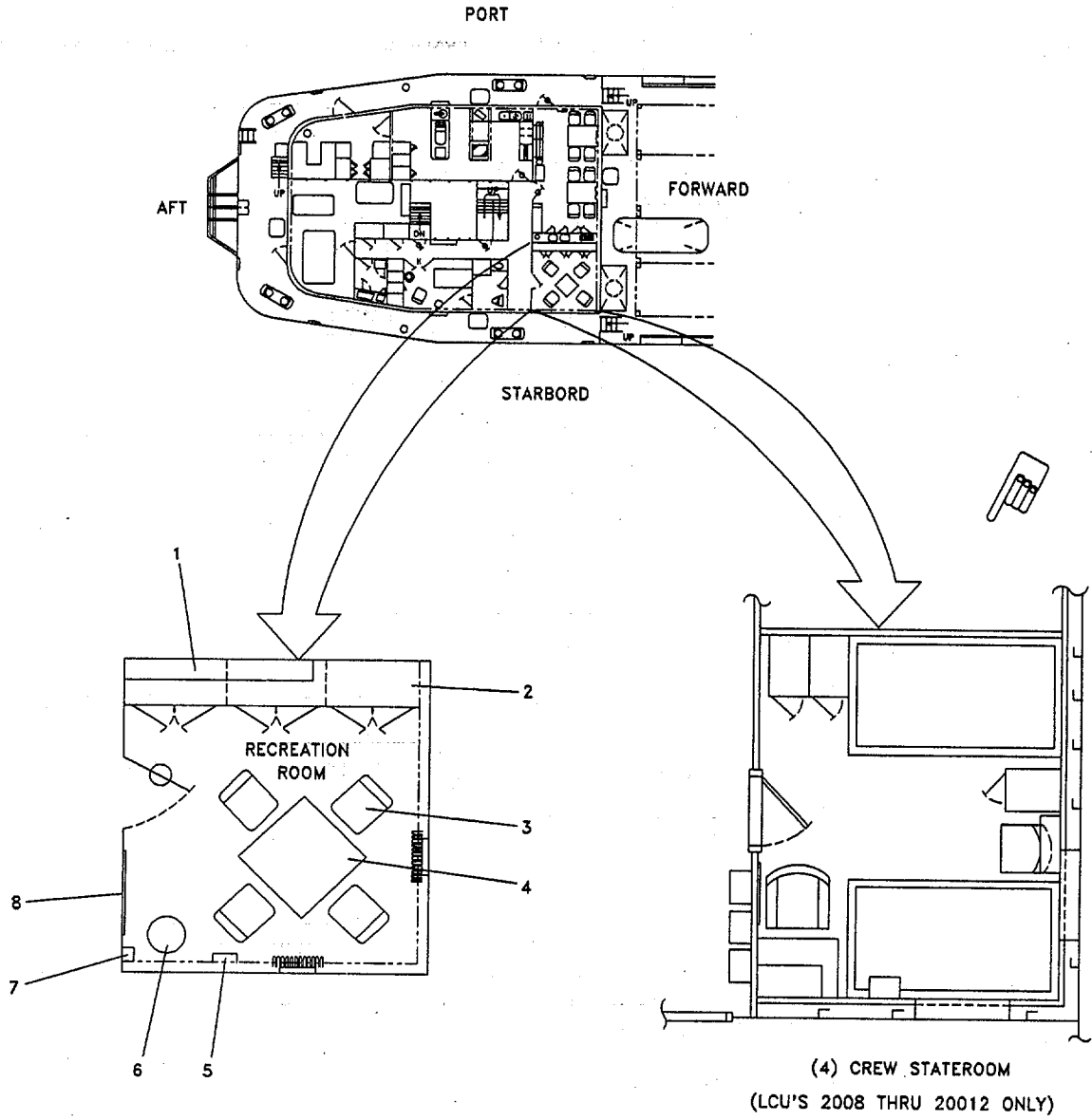

LEGEND

- 1. BOOKCASE
- 2. TV & VCR
- 3. CHAIRS
- 4. CARD TABLE
- 5. CLOCK
- 6. WASTE BASKET
- 7. INTERCOM
- 8. BULLETIN BOARD

FIGURE 1-15. Recreation Room/3 Crew Sr.

- (e) Sick bay and toilet area. FIGURE 1-16, includes a safe (1), refrigerator (2), tissue dispenser (3), Intercom LS-519A (4), night table (5), shower (6), sink (7), commode (8), single berth (9) with stokes litter, waste basket (10), clock (11), chair (12), wardrobe closet (13), medical locker (14), and desk/chest unit (15).

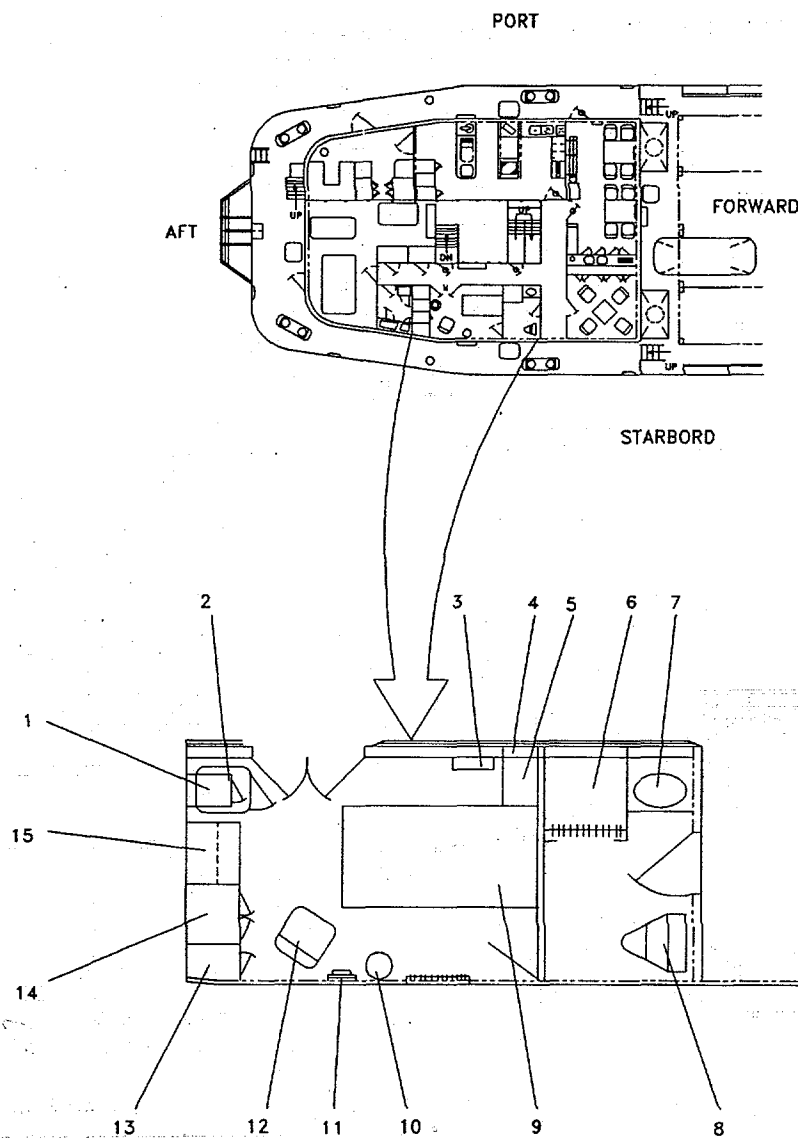

LEGEND

- |                     |                                    |
|---------------------|------------------------------------|
| 1. SAFE             | 9. SINGLE BERTH WITH STOKES LITTER |
| 2. REFRIGERATOR     | 10. WASTE BASKET                   |
| 3. TISSUE DISPENSER | 11. CLOCK                          |
| 4. INTERCOM         | 12. CHAIR                          |
| 5. NIGHT TABLE      | 13. WARDROBE CLOSET                |
| 6. SHOWER           | 14. MEDICAL LOCKER                 |
| 7. SINK             | 15. DESK/CHEST UNIT                |
| 8. COMMODOE         |                                    |

FIGURE 1-16. Sick Bay and Toilet Area.

- (f) Arms Control Room. FIGURE 1-17, contains locker (1), ammo locker (2), .50 caliber machine gun and M203 grenade launcher locker (3). Also installed is a fire detector, fire sprinkler system, and a shelf (4) for storage.

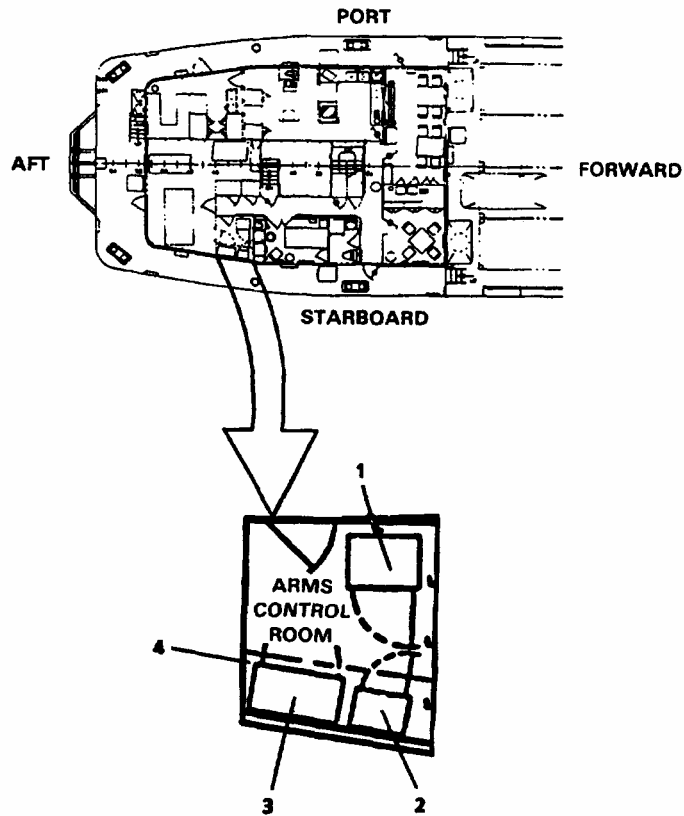

**LEGEND:**

- |                |   |
|----------------|---|
| 1. LOCKER      | 3. .50 CAL M/G M203 GRENADE LAUNCHER LOCKER |
| 2. AMMO LOCKER | 4. SHELF                                    |

FIGURE 1-17. Arms Control Room.



- (g) Air conditioning and emergency generator room. This room (FIGURE 1-18) contains battery chargers (1), emergency generator (2), fuel oil tank (3) for the emergency generator, emergency switchboard (4), HALON bottles (5), HALON stowage area (6), lube oil tank vent/overflow (7), 240/120V step down transformer for the emergency switchboard (8), 480/240V step down transformer (9), air supply fan (10), space heater (11), air conditioning unit (12), emergency access and escape for steering compartment (13), general alarm contact maker (14), fire pull box (15), sound powered phone (16) and a motor controller (17) for the supply fan (10).

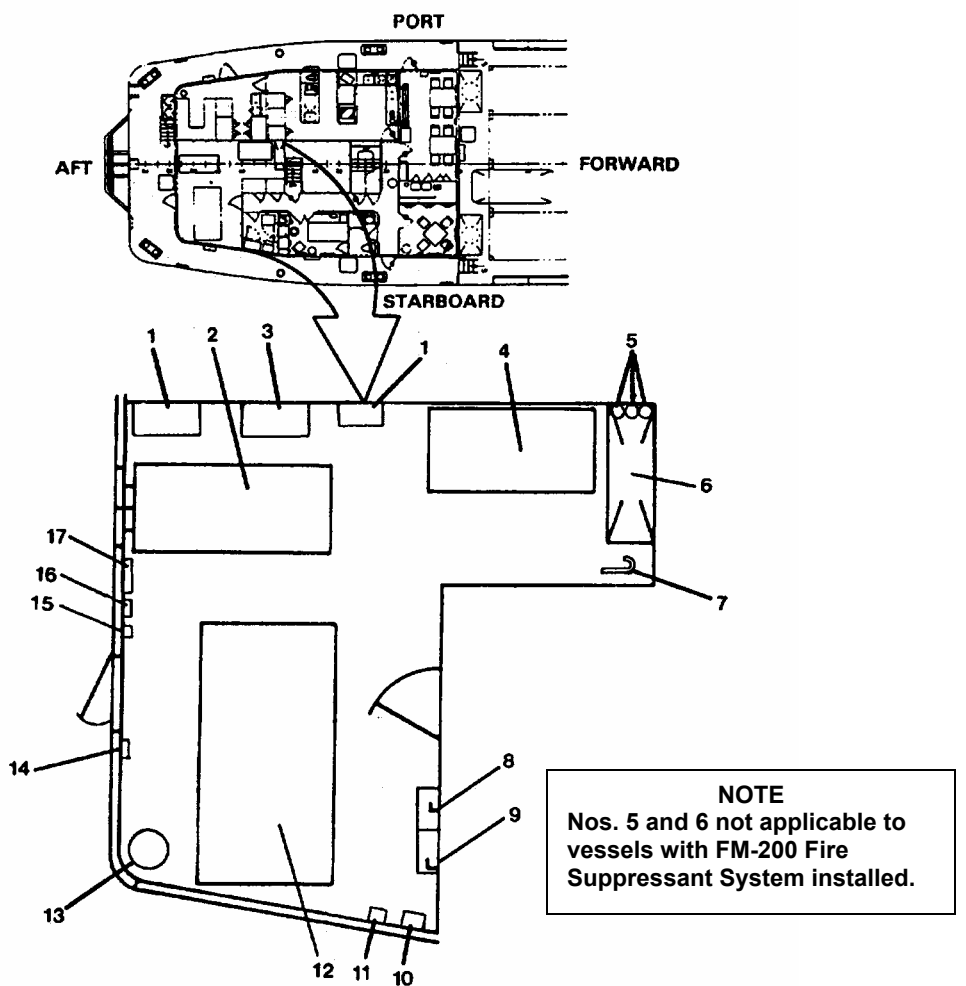

**LEGEND:**

- |   |  |
|---|--|
| 1. BATTERY CHARGER  | 10. SUPPLY FAN   |
| 2. EMERGENCY GENERATOR                                      | 11. SPACE HEATER   |
| 3. FUEL OIL TANK  | 12. AIR CONDITIONING UNIT                                    |
| 4. EMERGENCY SWITCHBOARD                                    | 13. EMERGENCY ACCESS AND ESCAPE FOR AFT STEERING COMPARTMENT |
| 5. HALON BOTTLES  | 14. GENERAL ALARM CONTACT MAKER                              |
| 6. HALON STORAGE  | 15. FIRE PULL BOX  |
| 7. LUBE OIL TANK VENT/OVERFLOW                              | 16. SOUND POWERED TELEPHONE                                  |
| 8. 240/120V STEP DOWN TRANSFORMER FOR EMERGENCY SWITCHBOARD | 17. EMERGENCY GENERATOR ROOM SUPPLY FAN MOTOR CONTROLLER     |
| 9. 480/240V STEP DOWN TRANSFORMER                           |  |

FIGURE 1-18. Air Conditioning and Emergency Generator Room.

(h) FIGURE 1-19 shows compartments of forward portion of the main deck and their contents.

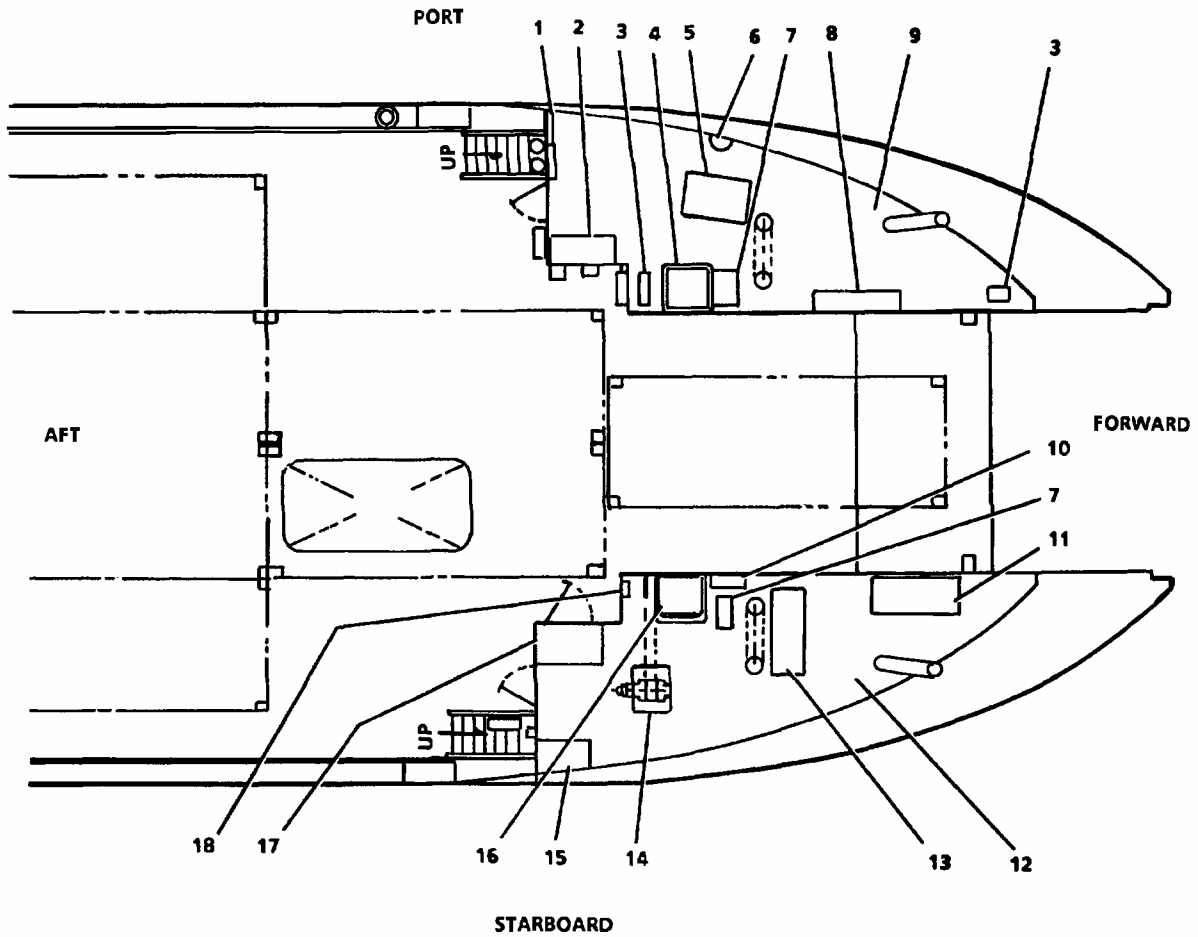

**LEGEND:**

- |  |   |
|--|---|
| 1. HALON BOTTLE ACTIVATION SYSTEM              | 10. BOW RAMP MOTOR CONTROLLER                               |
| 2. FLAMMABLES LOCKER                           | 11. BOW ANCHOR WINDLASS HYDRAULIC UNIT                      |
| 3. HEATER                                      | 12. BOATSWAIN STOWAGE                                       |
| 4. BOWTHRUSTER COMPARTMENT<br>SUPPLY FAN TRUNK | 13. BOW RAMP WINCH HYDRAULIC UNIT                           |
| 5. WORK BENCH                                  | 14. BOW RAMP WINCH  |
| 6. HALON WARNING LIGHT                         | 15. BOATSWAIN STOWAGE LOCKER                                |
| 7. STORAGE RACK                                | 16. BOWTHRUSTER COMPARTMENT ESCAPE<br>AND AIR EXHAUST TRUNK |
| 8. PAINT BRUSH CONTAINER                       | 17. MAIN DAMAGE CONTROL LOCKER                              |
| 9. PAINT LOCKER                                | 18. SOUND POWERED PHONE                                     |

FIGURE 1-19, Compartments of the Forward Section of the Main Deck,

**NOTE**

**Not applicable to vessels with FM-200 Fire Suppressant System installed. Reference paragraph 2-46 through 2-47 for FM-200 and Water Washdown System operation. Reference TM 55-1905-243-24&P, LCU 2000, FM-200 Fire Fighting System for maintenance and installation of FM-200 components.**

- 1 Paint locker (9). HALON protected area for the storage of paints and painting supplies. Contains HALON bottle activation system (1), flammable locker (2), space heater (3), workbench (5), storage rack (7), paint brush container (8) and a HALON Warning Light (6) which provides warning that the HALON system will discharge into the Paint Locker (9) in one minute.
- 2 Bowthruster compartment supply fan trunk (4). Provides forced air for the bowthruster compartment.
- 3 Bow anchor windlasses hydraulic unit (11). Provides electro-hydraulic power for the bow anchor windlasses.
- 4 Boatswains stowage (12). Storage of tie downs, chains and spare rope.
- 5 Bow ramp winch hydraulic unit (13). Provides electro-hydraulic power for the bow ramp winch operation. Controlled by bow ramp motor controller (10).
- 6 Bow ramp winch (14). A grooved drum, dual cable winch used to raise and lower the bow ramp.
- 7 Boatswains stowage locker (15). Storage of tie downs, chains and spare rope.
- 8 Bowthruster compartment escape and air exhaust trunk (16). Emergency escape route with quick acting scuttle and exhaust air ventilation for the bowthruster compartment.
- 9 Main damage control locker (17). Storage for damage control material.
- 10 Sound powered phone (18).

(5) Below Main Deck. The area below the main deck (FIGURE 1-20) includes the following compartments: steering gear compartment (1), engine room (5), engine room operating station (5), machine shop (11), tunnel (13), bowthruster compartment (17) and storeroom (20). Additionally, the following items are contained below main deck:

- Seawater Ballast SW-8 (Port and Starboard) (2)
- Fuel Tank F-7 (Port and Starboard) (3)
- Main Engine Day Tank (4)
- Sludge Tank (7)
- Dirty Oil Tank (8)
- Fresh Water FW-6 Tank (Port and Starboard) (9)
- Tool Locker (10)
- Seawater Ballast SW-5 (Port and Starboard) (12)
- Fuel Tank F-4 (Port and Starboard) (14)
- Fuel Tank F-3 (Port and Starboard) (15)
- Seawater Ballast SW-2 (Port and Starboard) (16)
- Bow Anchor Chain Lockers (Port and Starboard) (18)
- Seawater Ballast SW-1 (19)
- Main Sea Chest (21)
- Lube Oil Storage Tank (22)

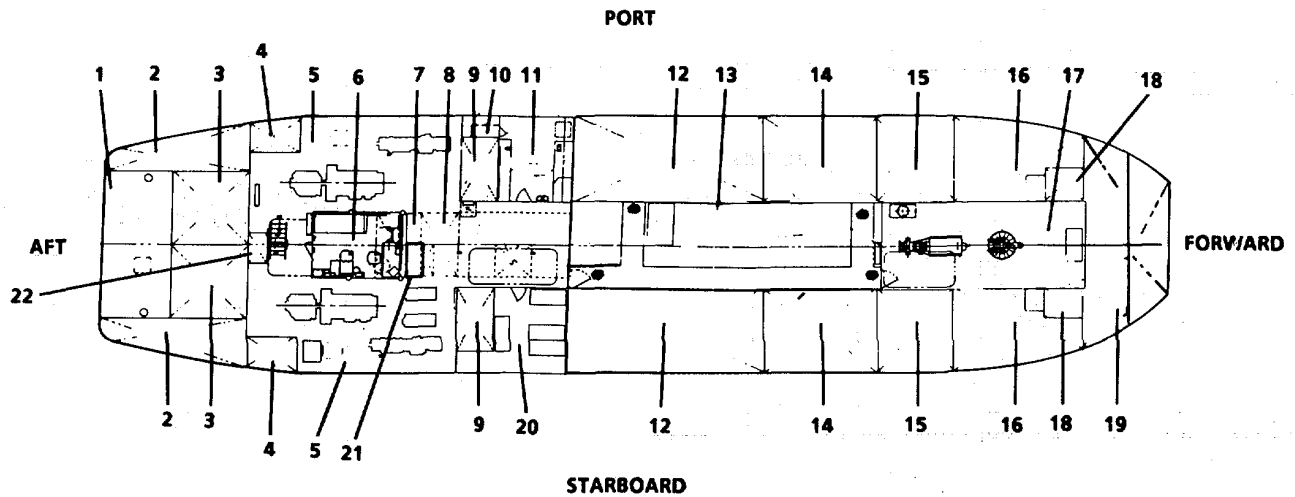

**LEGEND**

- |  |   |
|--|---|
| <ul style="list-style-type: none"> <li>1. STEERING GEAR COMPARTMENT</li> <li>2. SEA WATER BALLAST SW-8 (P/S)</li> <li>3. FUEL F-7 (P/S)</li> <li>4. MAIN ENGINE DAY TANKS (P/S)</li> <li>5. ENGINE ROOM</li> <li>6. ENGINE ROOM OPERATING STATION</li> <li>7. SLUDGE TANK</li> <li>8. DIRTY OIL TANK</li> <li>9. FRESH WATER FW-6 TANK (P/S)</li> <li>10. TOOL LOCKER</li> <li>11. MACHINE SHOP</li> </ul> | <ul style="list-style-type: none"> <li>12. SEA WATER BALLAST SW-5 (P/S)</li> <li>13. TUNNEL</li> <li>14. FUEL F-4 (P/S)</li> <li>15. FUEL F-3 (P/S)</li> <li>16. SEA WATER BALLAST SW-2 (P/S)</li> <li>17. BOWTHRUSTER COMPARTMENT</li> <li>18. BOW ANCHOR CHAIN LOCKERS (P/S)</li> <li>19. SEA WATER BALLAST SW-1</li> <li>20. STOREROOM</li> <li>21. MAIN SEA CHEST</li> <li>22. LUBE OIL STORAGE TANK</li> </ul> |
|--|---|

FIGURE 1-20. Below Main Deck.

(a) FIGURE 1-21 shows the equipment located in the steering gear compartment.

- 1 Follow up transmitter and linkage, port and starboard (1). Device that transmits to the rudder indicator the position of the rudder in reference to the center of the LCU.
- 2 Supply fan (2). Ventilation fan to steering gear compartment
- 3 Tiller, port and starboard (3). Lever used to control the direction of the rudder.
- 4 Tie bar (4). Linkage between port and starboard tillers.
- 5 Hydraulic cylinders, port and starboard (5). Hydraulic cylinders that activate the port and starboard tillers.
- 6 Steering compass repeater (6). Provides crew member in steering gear compartment compass bearing to follow pilothouse course change directions.
- 7 Steering power pack motor controllers, port and starboard (7). Separate motor controllers to control port and starboard electric motors of the steering hydraulic twin pump set.
- 8 Steering gear local control units, port and starboard (8). Unit transfers control to the pilothouse or to the local steering station in an emergency.
- 9 Intercom (9). Intercom system (LS-519A/SIC(U)) for the steering compartment.
- 10 Fire pull box (10). Pull box to activate the fire detection system.
- 11 Junction box (11). Junction box for the sound powered telephone system.
- 12 Bell (12). Bell to alert crew member in the steering gear compartment a call is coming in on the sound powered telephone.
- 13 Sound powered telephone (13). Used for ship's internal communication.
- 14 Sound powered telephone jack (14). Used to connect sound powered headset-chestset into system.
- 15 Telephone headset storage box (15). Storage container for the sound powered headset-chestset.
- 16 Stern anchor hydraulic pump motor controller (16). Motor controller to control the electric motor of the stern anchor hydraulic pump.
- 17 Rudder stock, port and starboard (17). Steel post that connects the rudder to the steering system, and directed by the tiller arm.

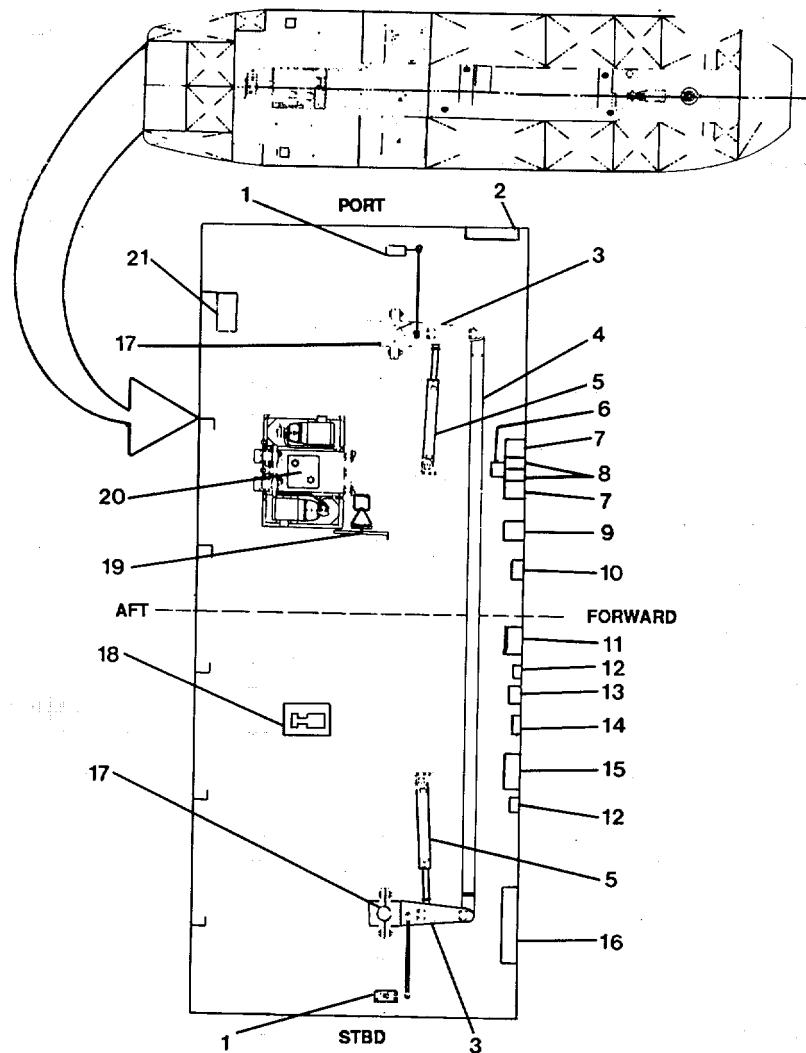

**LEGEND**

- |  |  |
|--|--|
| <ul style="list-style-type: none"> <li>1. FOLLOW UP TRANSMITTER AND LINKAGE</li> <li>2. SUPPLY FAN</li> <li>3. TILLER</li> <li>4. TIE BAR</li> <li>5. HYDRAULIC CYLINDER</li> <li>6. STEERING COMPASS REPEATER</li> <li>7. STEERING POWER PACK MOTOR CONTROLLERS</li> <li>8. STEERING GEAR LOCAL CONTROL UNIT</li> <li>9. INTERCOM</li> <li>10. FIRE PULL BOX</li> <li>11. JUNCTION BOX</li> </ul> | <ul style="list-style-type: none"> <li>12. BELL</li> <li>13. SOUND POWER TELEPHONE</li> <li>14. SOUND POWER TELEPHONE JACK</li> <li>15. TELEPHONE HEADSET STORAGE BOX</li> <li>16. STERN ANCHOR HYDRAULIC PUMP MOTOR CONTROLLER</li> <li>17. RUDDER STOCK</li> <li>18. STERN ANCHOR WINCH HYDRAULIC PUMP</li> <li>19. MANUAL HYDRAULIC PUMP</li> <li>20. STEERING HYDRAULIC DUAL PUMP SET</li> <li>21. HEATER</li> </ul> |
|--|--|

FIGURE 1-21. Steering Gear Compartment.

- 18 Stern anchor winch hydraulic pump (18). Hydraulic pump for the stern anchor winch.
- 19 Manual hydraulic pump (19). Allows the steering hydraulic pump to be manually operated when electric power is lost.
- 20 Steering hydraulic dual pump set (20). Two hydraulic pumps with a common reservoir provides hydraulic pressure for ship's steering system.
- 21 Heater (21). Heater for the steering compartment.

(b) Engine room, aft. Sheet 1, FIGURE 1-22 shows the equipment located in the aft section of the engine room.

- 1 Air compressors (1). Two air compressors stacked one above the other to supply compressed air to the storage tank.
- 2 Air dryer, (2). Dries compressed air before the storage tanks.
- 3 Port reduction gear (3). Transfers power from the port main engine to the port propeller shaft with a 4.941 to 1 reduction ratio.
- 4 Port main engine (4). Air started and fresh water cooled port main engine.
- 5 Fire extinguisher (5). Portable fire extinguisher.
- 6 Main switchboard (6). The main switchboard provides generator selection for control and power distribution for both 240 and 120 volts ac.
- 7 Starboard main engine (7). Air started and fresh water cooled starboard main engine.
- 8 Starboard reduction gear (8). Transfers power from the starboard main engine to the starboard propeller shaft with a 4.941 to 1 reduction ratio.
- 9 Marine sanitation device (9). This sewage treatment equipment is a biological aerobic (bacteria and air) system. Liquid and solid waste are removed from the water being treated by bacteria naturally contained in the sewage.
- 10 Reduction gear cooling pump pressure gauge (10). Gauge indicates the reduction gear oil pressure.
- 11 Reduction gear cooling pump (port and starboard) (11). Pump for circulating seawater to cool reduction gear oil.
- 12 P204 (12). Power panel for the engine room having the hot water booster pump circuit breaker and spare circuit breakers.
- 13 Prelube pump (13). Electric pump for prelubing the main engines.
- 14 Oil-water separator (14). 3 stage centrifugal device for removing water from lube oil.

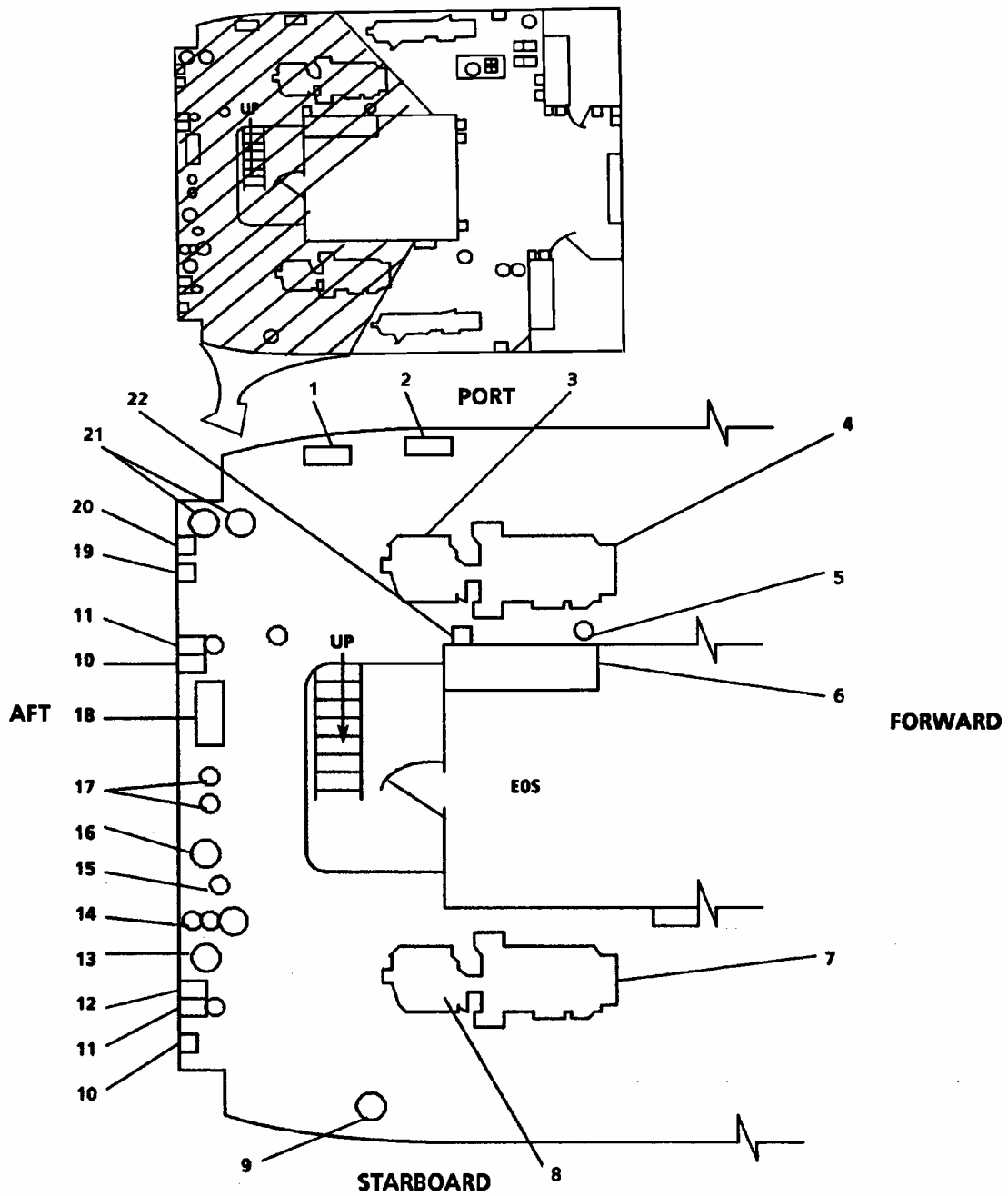

LEGEND:

- |                                       |                                 |
|---------------------------------------|---------------------------------|
| 1. AIR COMPRESSOR                     | 12. P204                        |
| 2. AIR DRYER                          | 13. PRELUBE PUMP                |
| 3. PORT REDUCTION GEAR                | 14. OIL-WATER SEPARATOR         |
| 4. PORT MAIN ENGINE                   | 15. PURIFIER PREHEATER          |
| 5. FIRE EXTINGUISHER                  | 16. LUBE OIL PURIFIER           |
| 6. MAIN SWITCHBOARD                   | 17. LUBE OIL HANDTRANSFER PUMPS |
| 7. STBD MAIN ENGINE                   | 18. FRESH WATER MAKERS          |
| 8. STBD REDUCTION GEAR                | 19. P203                        |
| 9. MARINE SANITATION DEVICE           | 20. L102                        |
| 10. REDUCTION GEAR COOLING PUMP       | 21. AIR RECEIVER                |
| PRESSURE GAUGE (P/S)                  | 22. FIRE STATION                |
| 11. REDUCTION GEAR COOLING PUMP (P/S) |                                 |

FIGURE 1-22. Engine Room (Sheet 1 of 2).



- 15 Purifier preheater (15). Heater to warm lubricating oil for efficient purification.
- 16 Lube oil purifier (16). Purifies lubricating oil for all diesel engines.
- 17 Lube oil hand transfer pumps (17). Two manual hand operated pumps to transfer lubricating oil to selected diesel engines.
- 18 Fresh water makers (2), (18). Reverse osmosis machines for removing crystals and solids for the fresh water system.
- 19 P203 (19). Electric power panel for engine room and steering gear room heaters.
- 20 L102 (20). Lighting panel for the engine room area.
- 21 Air receivers (21). Two storage tanks for the compressed air system.
- 22 Fire station No. 2 (22). Fire station for the engine room using seawater. Has 50 ft., 1 ½ in. hose with all purpose nozzle.

(c) Engine room, forward. Sheet 2, FIGURE 1-22 shows the equipment located in the forward section of the engine room.

- 1 Port ship service generator (23). Air started and fresh water cooled diesel engine for the port ship service generator.
- 2 Fuel filter/coalescer (24). Filters and removes water from the fuel.
- 3 Fuel transfer pumps (25). Two electric fuel pumps to transfer fuel oil in the fuel oil transfer system.
- 4 Fresh water pump motor controller (26, 31). Motor controllers for the fresh water pumps.

**NOTE**

**Not applicable to vessels with FM-200 Fire Suppressant System installed. Reference paragraph 2-46 through 2-47, for FM-200 and Water Washdown operation. Reference TM 55-1905-243-24&P, LCU-2000, FM-200 Fire Fighting System, for maintenance and installation of FM-200 components.**

- 5 HALON warning light (27). Amber light to warn personnel to evacuate engine room because HALON system is about to discharge (port and starboard).
- 6 Dirty lube oil pump (28). Provides pressure to move the dirty lube oil to the lube oil purifier.
- 7 Fresh water pressure tank (29). Stores potable water under pressure for the ship's potable water system.
- 8 Fresh water pumps (30). Two fresh water pumps for transferring potable water from tanks to system.
- 9 Fresh water tank (32). Ship's potable water storage tanks.
- 10 Machine shop (33). Used by engineering personnel for ship's equipment repairs and maintenance.

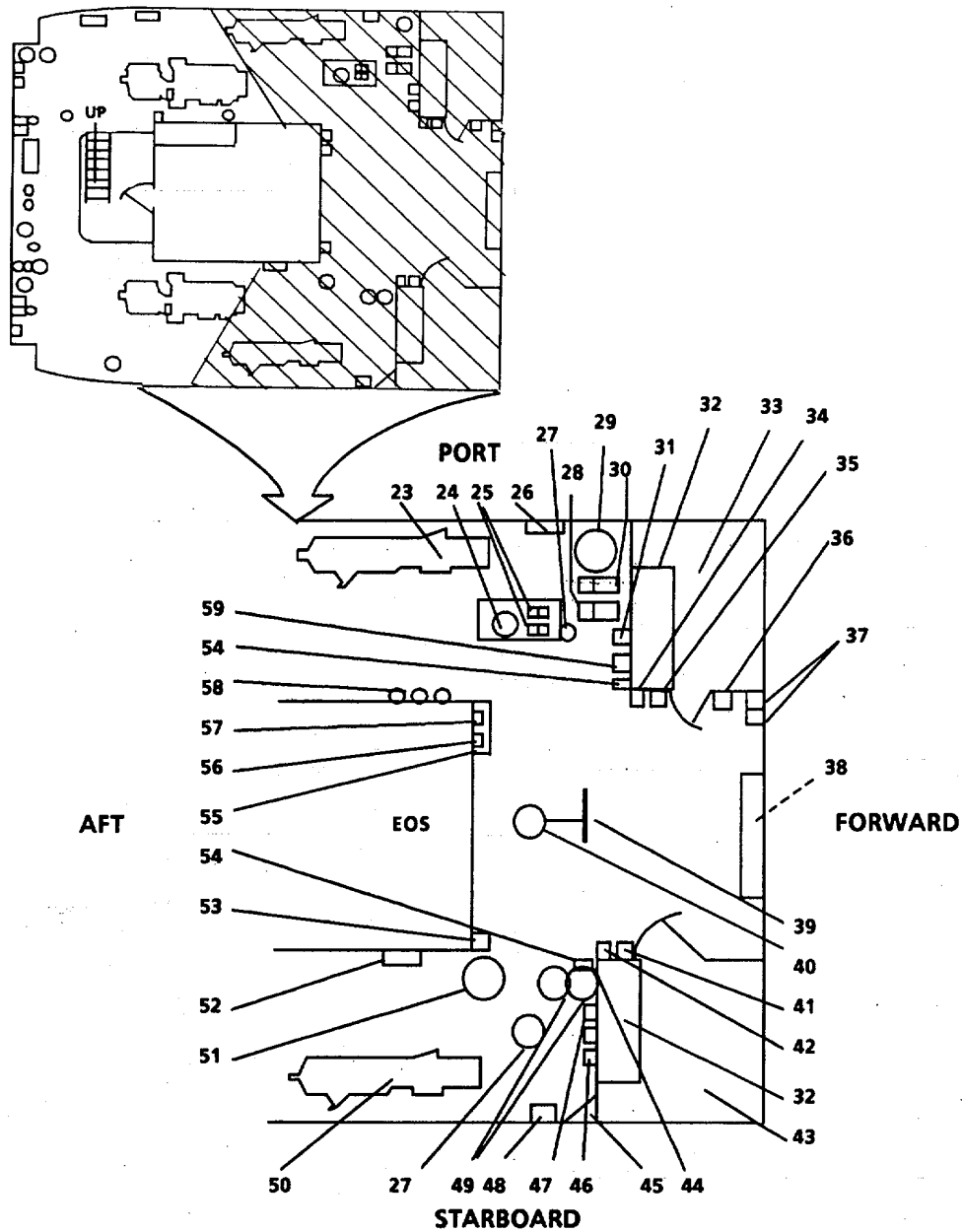

**LEGEND**

- |  |                                   |
|--|-----------------------------------|
| 23. PORT SHIP SERVICE GENERATOR        | 43. STORE ROOM                    |
| 24. FUEL FILTER/COALESCER              | 44. FIRE PUMP MOTOR SWITCH (2)    |
| 25. FUEL TRANSFER PUMPS                | 45. TANK LEVEL INDICATORS         |
| 26. NO. 2 FW PUMP MOTOR CONTROLLER     | 46. BATTERY STORAGE BOX (2)       |
| 27. HALON WARNING LIGHT (AMBER)        | 47. FIRE PUMP GAUGES              |
| 31. NO. 1 FW PUMP MOTOR CONTROLLER     | 48. BATTERY CHARGER               |
| 28. DIRTY LUBE OIL PUMP                | 49. ELECTRIC FIRE PUMPS           |
| 29. FRESH WATER PRESSURE TANK          | 50. STBD SHIP SERVICE GENERATOR   |
| 30. FRESH WATER PUMPS (2)              | 51. BILGE/BALLAST PUMP            |
| 32. FRESH WATER TANK                   | 52. SEA WATER CIRCULATING PUMP    |
| 33. MACHINE SHOP                       | 53. BILGE/BALLAST PUMP CONTROLLER |
| 34. FIRE STATION NO. 1                 | 54. TELEPHONE HEADSET STORAGE     |
| 35. TUNNEL VENT FAN CONTROLLER         | 55. BOX & SOUND POWERED TELEPHONE |
| 36. VENTILATION CONTROL CENTER         | 56. FUEL SUPPLY MANIFOLD          |
| 37. FIRE PUMP CONTROLLERS              | 57. ENGINE EFFICIENCY PANEL       |
| 38. AUXILIARY MACHINERY CONTROL CENTER | 58. TANK LEVEL INDICATORS         |
| 39. SLUDGE TANK INDICATOR              | 59. FUEL SUCTION MANIFOLD         |
| 40. GENERAL ALARM LIGHT (RED)          |                                   |
| 41. FOAM EDUCTORS                      |                                   |
| 42. FOAM FIRE STATION NO. 1            |                                   |

FIGURE 1-22. Engine Room (Sheet 2 of 2).

- 11 Fire station No. 1 (34). Fire station for the engine room using seawater. Has 50 feet of 1-1/2 inch hose with an all-purpose nozzle.
- 12 Tunnel vent fan controller (35). Motor controller for tunnel vent fan.
- 13 Ventilation control center (36). Four motor controllers for engine room ventilation.
- 14 Fire pump controllers (37). Motor controllers for the fire pump number 1 and pump number 2.
- 15 Auxiliary Machinery Controller Center (38). Central location for different motor controllers.
- 16 Sludge Tank Indicator (39). Tank level indicator for the sludge tank.
- 17 General alarm light (40). Red light provides visual indication of general alarm status.
- 18 Foam Eductors (41). Controls to the foam supply tank.
- 19 Foam Fire Station No. 1 (42). Fire station for the engine room with seawater or foam. Has 50 ft of 2-1/2 inch hose with an all-purpose nozzle.
- 20 Store room (43). Store room for spare parts.
- 21 Fire pump motor switch (44). Two STOP-START type I motor switch for the fire pumps.
- 22 Tank level indicators (45). Indicators for the fresh water tanks and the ballast tanks.
- 23 Battery storage box (46). Two battery storage boxes provide backup power to start the starboard SSDG (50).
- 24 Fire pump gauges (47). Pressure gauges for the fire pump discharge.
- 25 Battery charger (48). Battery charger for the starboard generator batteries.
- 26 Electric fire pumps (49). Seawater fire pumps to pressurize the fire main.
- 27 Starboard ship service generator (50). Battery started and fresh water cooled diesel engine for the starboard ship service generator.
- 28 Bilge/ballast pump (51). Pump to ballast the LCU and/or pump the bilges.
- 29 Seawater circulating pump (52). Pump that circulates seawater for the stern tubes, marine sanitation device, water makers, and air conditioning system.
- 30 Bilge/ballast pump controller (53). Motor controller for the bilge/ballast pump.

- 31 Telephone headset storage box and sound powered telephone (54). Used for ship's internal communication.
- 32 Fuel supply manifold (55). Manifold for the supply side of the fuel oil transfer system.
- 33 Engine efficiency panel (56). Electronic panel for monitoring the different conditions of the diesel main engines.
- 34 Tank level indicators (57). Indicators for the fuel oil tanks.
- 35 Fuel suction manifold (58). Manifold for the fuel oil tanks.
- 36 Fuel transfer pump controller (59). Motor controller for the fuel oil transfer system.

(d) The engine room operating station looking forward is shown in Sheet 1, FIGURE 1-23.

- 1 Key box (1). Secure storage for keys.
- 2 File cabinet (2). Storage of maintenance forms and records.
- 3 Engine efficiency panel (3). Contains main and field power switches, and the primary or backup selection switch for the engine efficiency monitor.
- 4 Window (4). Window to forward section of engine room.
- 5 Intercom (5). Intercom system for the engine room operating station.
- 6 Alarm bell, fire (6). Fire alarm bell.
- 7 Marine sanitation monitor panel (7). Monitors and self checks the marine sanitation device.
- 8 Engine room console (8). Central control for main engines and machinery plant monitoring systems.
- 9 Steps (9). Two steps for access to escape hatch.
- 10 120 Vac distribution transformer (10). Transformer to convert ship's 240 Vac primary power to ship's 120 Vac secondary power.

(e) The engine room operating station looking starboard is shown in Sheet 2 of FIGURE 1-23.

- 1 Window (11). Windows to starboard section of engine room.
- 2 Phone station (12). Insulated enclosure to deaden engine room noise for telephone use.
- 3 Sound powered telephone jackbox (13). Jackbox for telephone headset.
- 4 Sound powered telephone (14). Used for ship's internal communication.

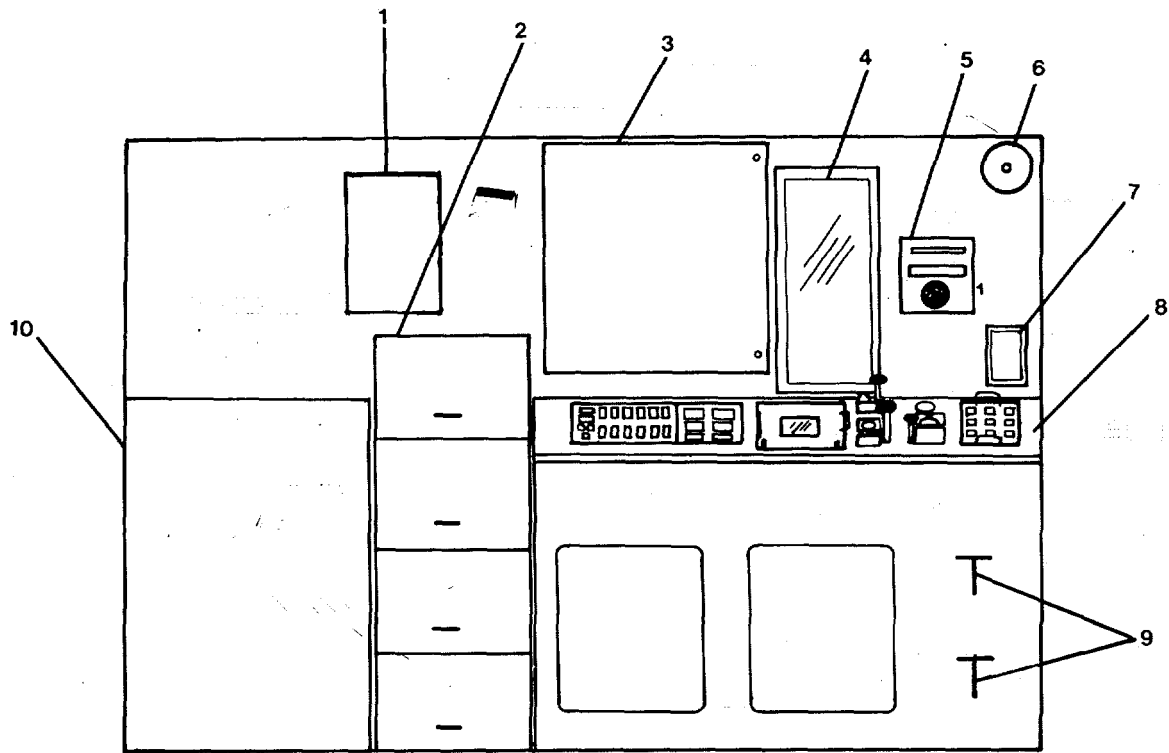

INSIDE EOS LOOKING FORWARD

**LEGEND**

- |   |  |
|---|--|
| <ul style="list-style-type: none"> <li>1. KEY BOX</li> <li>2. FILE CABINET</li> <li>3. ENGINE EFFICIENCY PANEL</li> <li>4. WINDOW</li> <li>5. INTERCOM</li> </ul> | <ul style="list-style-type: none"> <li>6. ALARM BELL, FIRE</li> <li>7. MARINE SANITATION MONITOR PANEL</li> <li>8. ENGINE ROOM CONSOLE</li> <li>9. STEPS</li> <li>10. 120V DISTRIBUTION TRANSFORMER</li> </ul> |
|---|--|

FIGURE 1-23. Engine Room Operating Station (Sheet 1 of 4).

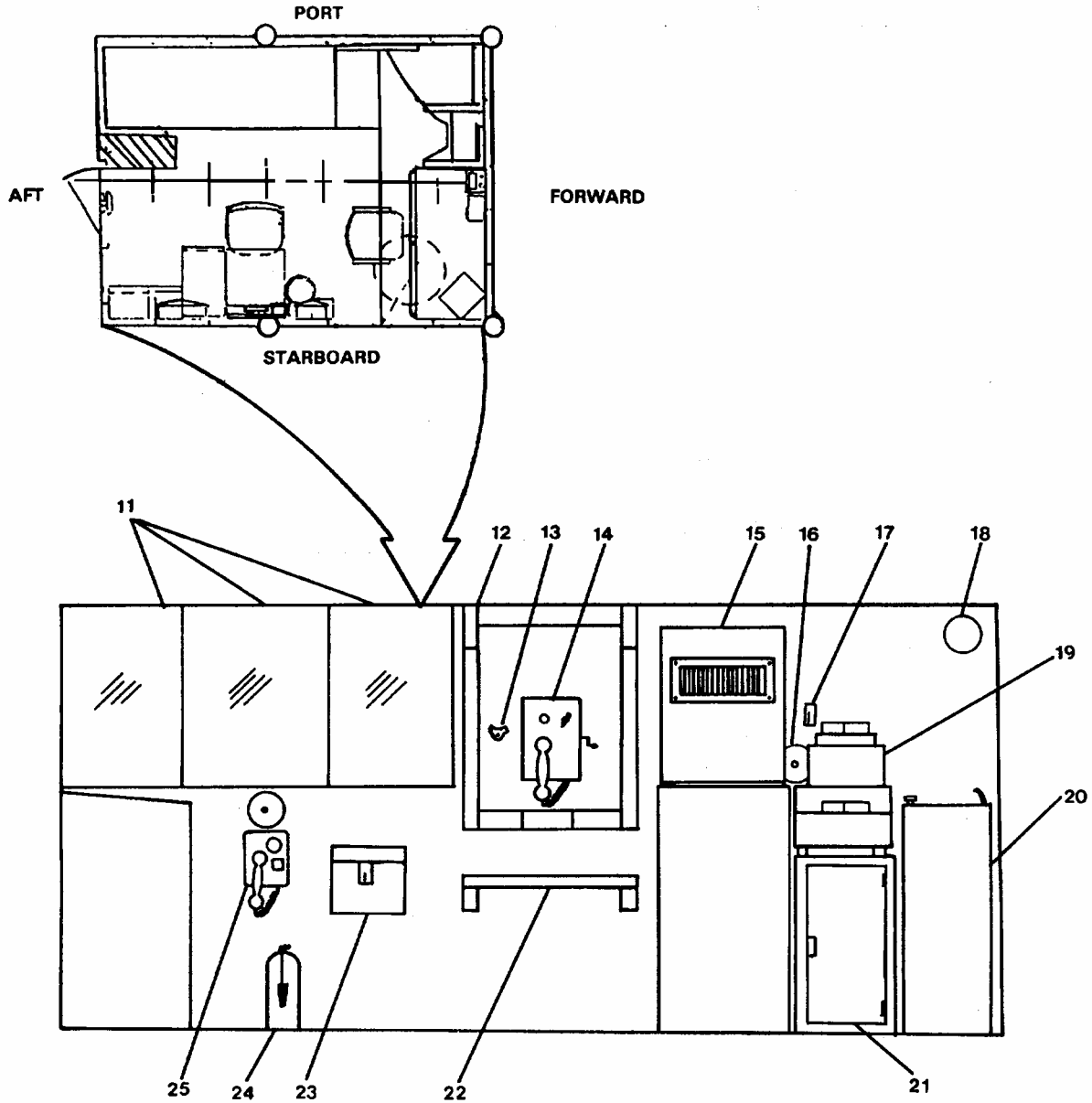

INSIDE EOS LOOKING STARBOARD

LEGEND:

- |                                      |                                   |
|--------------------------------------|-----------------------------------|
| 11. WINDOW                           | 18. HALON FIRE SYSTEM ALARM       |
| 12. PHONE STATION                    | 19. COFFEE POT                    |
| 13. SOUND POWERED TELEPHONE JUNCTION | 20. WATER FOUNTAIN                |
| 14. SOUND POWERED TELEPHONE          | 21. STORAGE CABINET               |
| 15. AIR CONDITIONING UNIT            | 22. WRITING SHELF                 |
| 16. GENERAL ALARM BELL               | 23. TELEPHONE HEADSET STORAGE BOX |
| 17. AIR CONDITIONER THERMOSTAT       | 24. FIRE EXTINGUISHER             |
|                                      | 25. SOUND POWERED TELEPHONE       |

FIGURE 1-23. Engine Room Operating Station (Sheet 2 of 4).

- 5 Air conditioning unit (15). Provides air conditioning for the engine room operating station.
- 6 General alarm bell (16).
- 7 Air conditioner thermostat (17).

**NOTE**

**Not applicable to vessels with FM-200 Fire Suppressant System installed. Reference paragraph 2-46 through 2-47 for FM-200 and Water Washdown System operation. Reference TM 55-1905-243-24&P, LCU-2000, FM-200 Fire Fighting System for maintenance and installation of FM-200 components.**

- 8 HALON fire system alarm (18).
  - 9 Coffee pot (19). Two pot coffee unit with coffee pot guards.
  - 10 Water fountain (20). Supplies chilled drinking water for personnel.
  - 11 Storage cabinet (21). Storage for engine room operating station supplies.
  - 12 Writing shelf (22). Shelf for copying telephone information and writing reports.
  - 13 Telephone headset storage box (23). Storage container for the sound powered headset and chestset.
  - 14 Fire extinguisher (24).
  - 15 Sound powered telephone (25). Used for ship's internal communication.
- (f) The engine operating station looking aft is shown in Sheet 3, FIGURE 1-23.
- 1 Window (26). Windows to aft section of engine room.
  - 2 Door (27). Door to aft section of engine room.
- (g) The engine room operating station looking to port is shown in Sheet 4, FIGURE 1-23.
- 1 Main switchboard (28). The main switchboard includes generator sections for control, paralleling and power distribution for both 240 and 120 volts ac.
  - 2 Window (29). Windows to port section of engine room.
  - 3 Survival suit stowage (30).
- (h) The machine shop is shown in FIGURE 1-24.
- 1 Workbenches (1). Sturdy bench for repair of mechanical units.
  - 2 Welding machine motor controller (2). Motor controller for the welding machine.
  - 3 Welding machine (3). Arc welding machine for ship's equipment repairs.
  - 4 Bench grinder (4). Grinder for tool sharpening and equipment repairs.

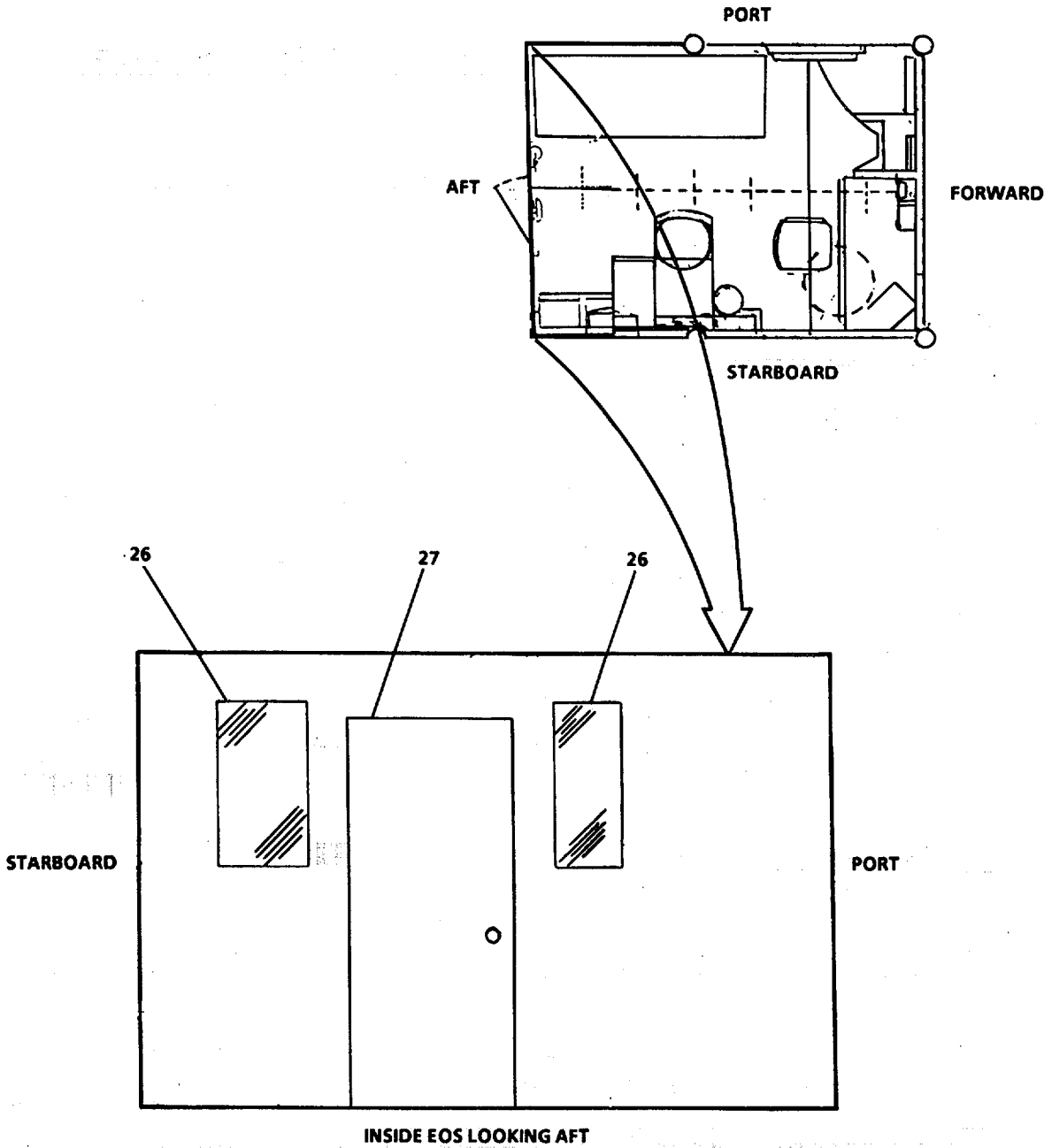

**LEGEND**  
26. WINDOW

27. DOOR

FIGURE 1-23. Engine Room Operating (Sheet 3 of 4).



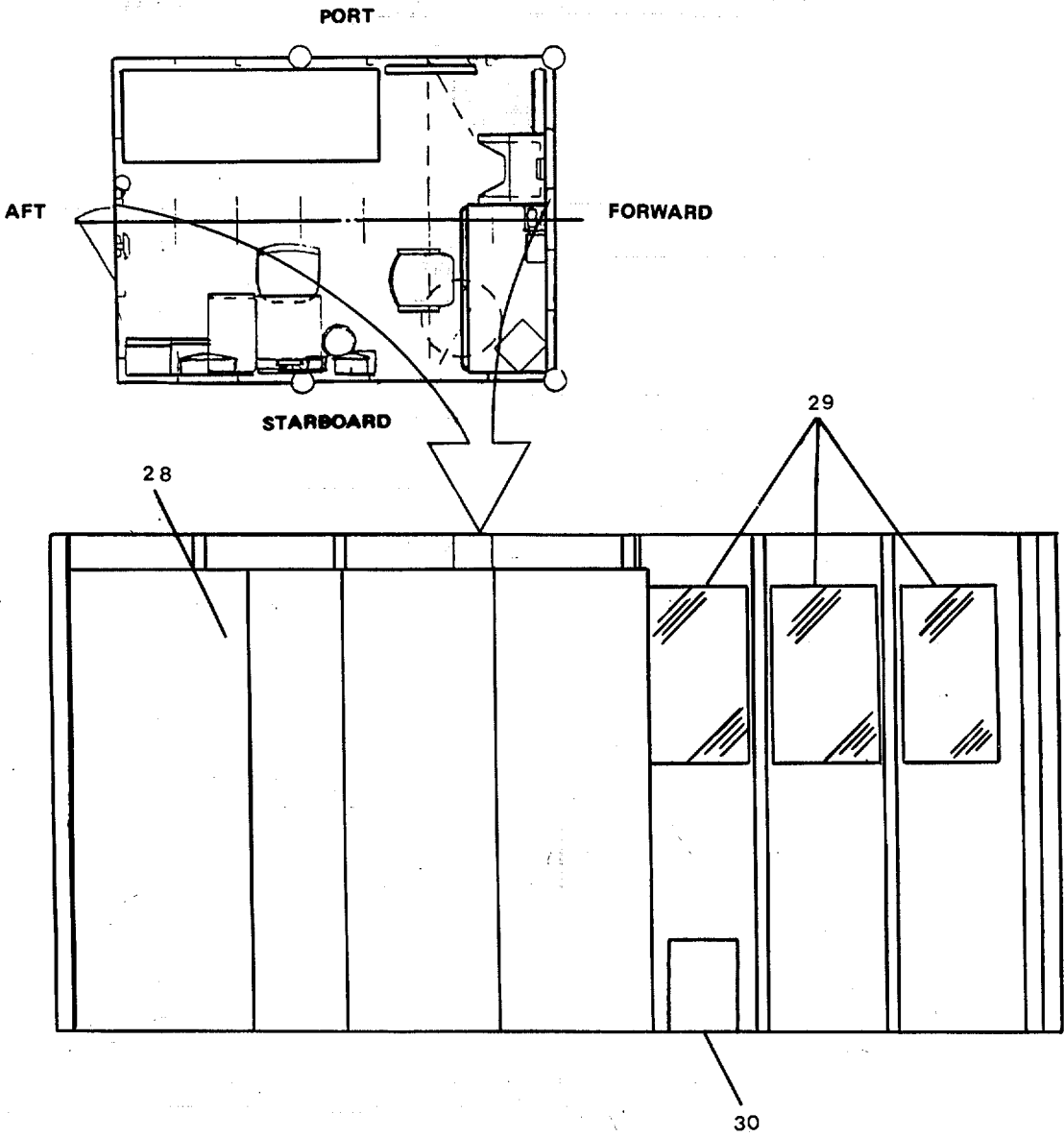

**LEGEND**  
28. MAIN SWITCHBOARD  
29. WINDOW

30. SURVIVAL SUIT STORAGE

FIGURE 1-23. Engine Room Operating Station (Sheet 4 of 4).

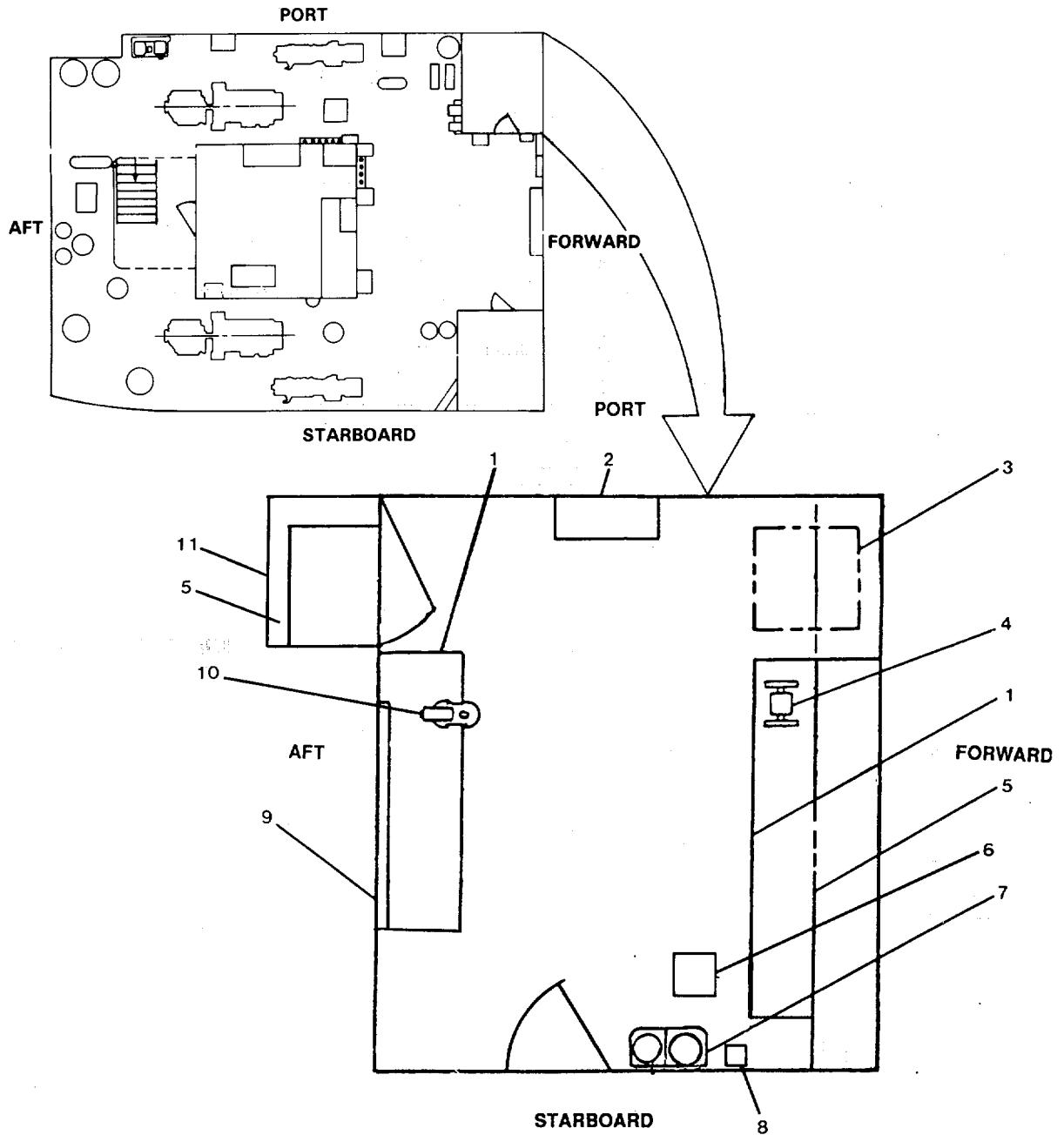

**LEGEND**

- |                                     |                              |
|-------------------------------------|------------------------------|
| 1. WORKBENCH                        | 7. ACETYLENE TANKS           |
| 2. WELDING MACHINE MOTOR CONTROLLER | 8. INTERCOM                  |
| 3. WELDING MACHINE                  | 9. TOOL BOARD                |
| 4. BENCH GRINDER                    | 10. VISE                     |
| 5. SHELF                            | 11. SECURE TOOL STORAGE ROOM |
| 6. HEATER                           |                              |

FIGURE 1-24. Machine Shop.

- 5 Shelf (5). Storage of technical manuals.
- 6 Heater (6). Space heater for the machine shop.
- 7 Acetylene torch (7). For metal cutting and shaping.
- 8 Intercom (8). Intercom system (LS-519A) for the machine shop.
- 9 Tool board (9). For display and storage of hand tools.
- 10 Vise (10). For holding equipment being worked on.
- 11 Secure tool storage room (11). Tool room with lockable hasp.

(i) Storeroom compartment is shown in FIGURE 1-25 with storage racks (1).

(j) Tunnel compartment is shown FIGURE 1-26.

- 1 Manual hand pump (1). Hand pump to transfer hydraulic fluid from storage tank.
- 2 Hydraulic fluid storage tank (2). Storage tank for ship's hydraulic fluid.
- 3 Tank level indicator (3). Indicates level of hydraulic fluid.
- 4 Spare shafts (4). Storage for two spare main shafts in case of damage.
- 5 Space heater (5). Heaters for the tunnel compartment.
- 6 Bowthruster day tank shut off (6). Shut off supply valve for fuel to the bowthruster day tank.
- 7 Air isolation valve (7). Isolation valve to the seachest, service air to the main deck, and service air to the bowthruster compartment.
- 8 P211 (8). Power panel for ventilation fans for tunnel, bowthruster compartment, paint locker, galley, emergency generator room, and sanitary spaces.
- 9 Fire pull box (9). Pull box to activate the fire detection system.
- 10 Fire station (10). Seawater fire station with 50 ft of 1-1/2 inch hose and an all purpose nozzle.
- 11 Bow windlass/bowthruster motor controller (11). Motor controller for bow windlass and bowthruster jacket water heater.
- 12 Damage Control Lumber Rack (12). Storage rack for the damage control lumber.
- 13 Walkway (13). Decking for walking in the tunnel.
- 14 Spare propeller (14). Stowage for spare propeller.

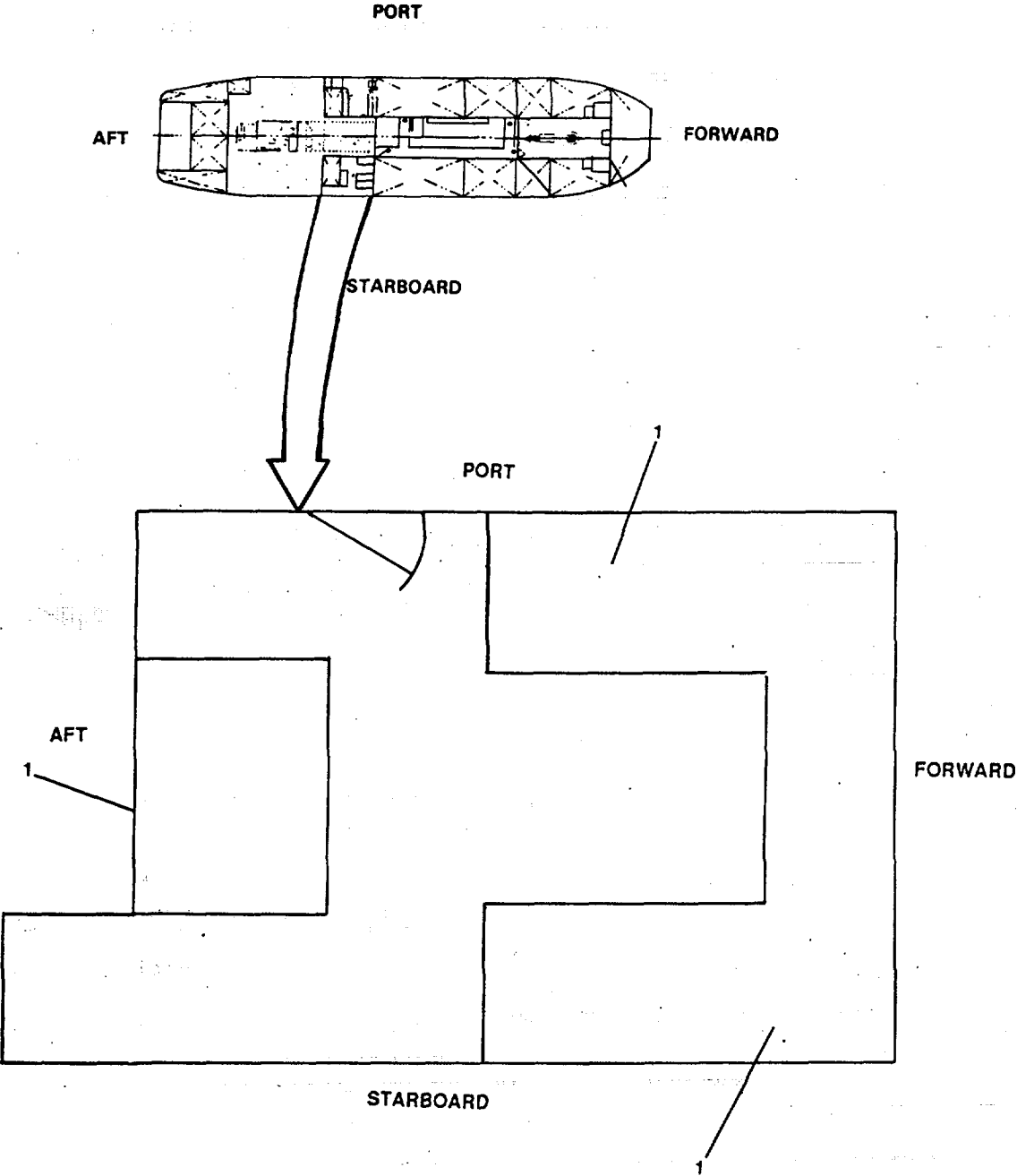

**LEGEND**  
1. STORAGE RACKS

FIGURE 1-25. Storeroom.

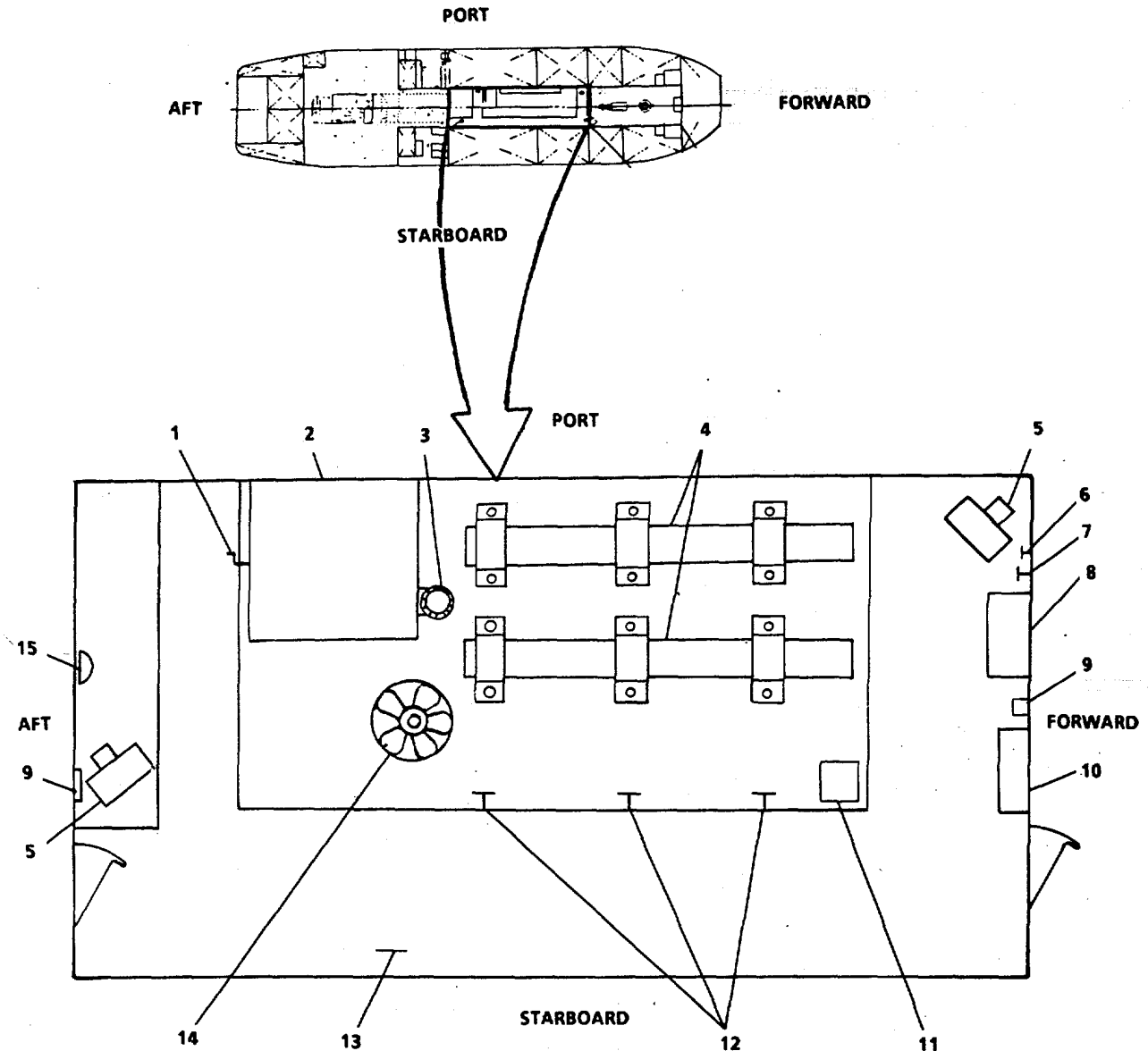

**LÉGEND**

- |                                  |                                |
|----------------------------------|--------------------------------|
| 1. MANUAL HAND PUMP              | 10. FIRE STATION               |
| 2. HYDRAULIC FLUID STORAGE TANK  | 11. BOW WINDLASS/BOWTHRUSTER   |
| 3. TANK LEVEL INDICATOR          | MOTOR CONTROLLER, BOWTHRUSTER  |
| 4. SPARE SHAFTS                  | JACKET WATER HEATER            |
| 5. SPACE HEATER                  | 12. DAMAGE CONTROL LUMBER RACK |
| 6. BOWTHRUSTER DAY TANK SHUT OFF | 13. WALKWAY                    |
| 7. AIR ISOLATION VALVE           | 14. SPARE PROPELLER            |
| 8. P211                          | 15. GENERAL ALARM              |
| 9. FIRE PULL BOX                 |                                |

FIGURE 1-26. Tunnel.

- 15 General alarm (15). Alarm bell to call personnel to their assigned station for emergency situation.
- (k) The bowthruster compartment is shown, in FIGURE 1-27.
- 1 Bowthruster day tank (1). Fuel oil storage for bowthruster engine.
- 2 Fire pump (2). Auxiliary fire pump powered by the bowthruster diesel engine.
- 3 Battery Box (3). Two battery boxes containing four 6V batteries each hooked in parallel.
- 4 Battery charger (4). Charger for bowthruster engine batteries.
- 5 Sound powered telephone (5). Used for ship's internal communication.
- 6 Sound powered telephone jack (6). Used to connect sound powered head- set-chestset into system.
- 7 Telephone headset storage box (7). Storage container for the sound powered headset and chestset.
- 8 Intercom (8). Intercom system (LS-519/A) for the bowthruster compartment.
- 9 Bowthruster waterjet set (9). A high volume jet pump driven by the bowthruster diesel engine. Twin hydraulic steering motors point the jet nozzle in the desired direction.
- 10 Ventilation supply shaft (10). Air shaft from forecastle deck with a supply fan in it.
- 11 Manual hand pumps (11). Hand pumps to drain the anchor chain compartments.
- 12 Space heater (12).
- 13 P211-4 (13). Motor controller for the paint locker exhaust fan.
- 14 P211-3 (14). Motor controller for the bowthruster room supply fan.
- 15 Start-stop motor controller (15). Local start-stop controller for the port anchor windlass hydraulic power unit.
- 16 Port anchor windlass hydraulic power unit (16). Provides electro-hydraulic power for the port anchor windlass.
- 17 P201 (17). Electric power panel for unit heaters in the tunnel, paint locker, boatswain storeroom, bowthruster compartment, and pilothouse.
- 18 Fire pull box (18). Pull box to activate the fire alarm.

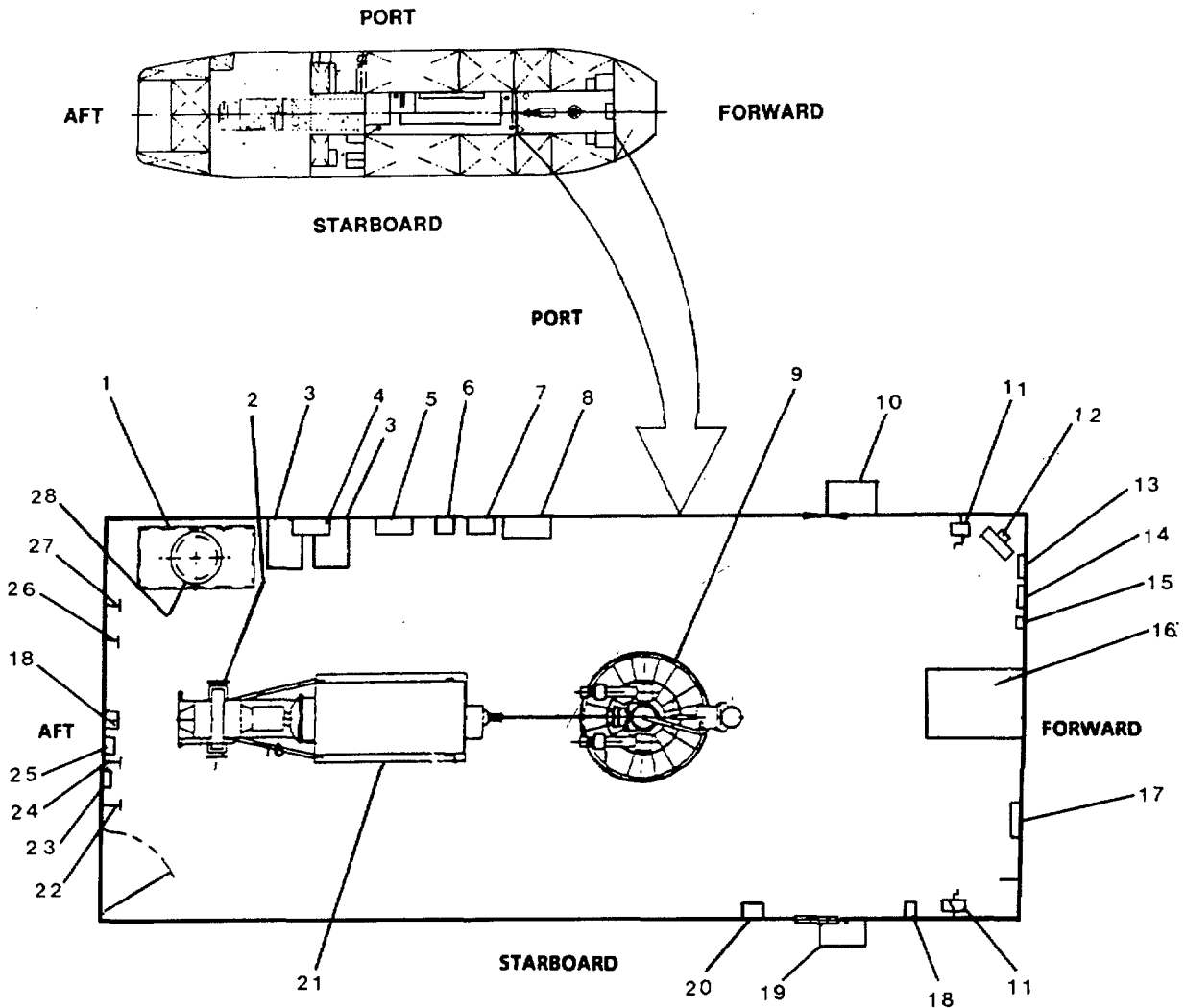

**LEGEND**

- |   |  |
|---|--|
| <ul style="list-style-type: none"> <li>1. BOWTHRUSTER DAY TANK</li> <li>2. FIRE PUMP</li> <li>3. BATTERY BOX</li> <li>4. BATTERY CHARGER</li> <li>5. SOUND POWERED TELEPHONE</li> <li>6. SOUND POWERED TELEPHONE JACK</li> <li>7. TELEPHONE HEADSET STORAGE BOX</li> <li>8. INTERCOM</li> <li>9. BOWTHRUSTER WATERJET SET</li> <li>10. VENTILATION SUPPLY SHAFT</li> <li>11. MANUAL HAND PUMPS</li> <li>12. SPACE HEATER</li> <li>13. P211-4</li> <li>14. P211-3</li> <li>15. START-STOP MOTOR CONTROLLER</li> <li>16. PORT ANCHOR WINDLASS HYDRAULIC POWER UNIT</li> </ul> | <ul style="list-style-type: none"> <li>17. P201</li> <li>18. FIRE PULL BOX</li> <li>19. EXHAUST VENTILATION/ESCAPE HATCH</li> <li>20. REMOTE BOWTHRUSTER CONTROL</li> <li>21. BOWTHRUSTER ENGINE</li> <li>22. FUEL TRANSFER ISOLATION VALVE STBD TANK 3</li> <li>23. FIRE MAIN SUCTION GAUGE</li> <li>24. FUEL TRANSFER ISOLATION VALVE STBD TANK 4</li> <li>25. FIRE MAIN DISCHARGE GAUGE</li> <li>26. FUEL TRANSFER ISOLATION VALVE PORT TANK 4</li> <li>27. FUEL TRANSFER ISOLATION VALVE PORT TANK 3</li> <li>28. SEA CHEST BLOWDOWN VENT</li> </ul> |
|---|--|

FIGURE 1-27. Bowthruster Compartment.

- 19 Exhaust ventilation/escape hatch (19). Air shaft to the forecast deck having a built in ladder for exit to the forecastle deck.
- 20 Remote bowthruster control (20). Bulkhead mounted control to direct the bowthruster waterjet set.
- 21 Bowthruster engine (21). Electric start diesel engine that powers the bowthruster waterjet set or the fire pump.
- 22 Fuel transfer isolation valve STBD tank 3 (22). Valve to open or close the starboard fuel tank number 3 for fuel transfer.
- 23 Fire main suction gauge (23). Gauge to show suction pressure of the fire main.
- 24 Fuel transfer isolation valves STBD tank 4 (24). Valve to open or close the starboard fuel tank number 4 for fuel transfer.
- 25 Fire main discharge gauge (25). Gauge to show discharge pressure of the fire main.
- 26 Fuel transfer isolation valve port tank 4 (26). Valve to open or close the port fuel tank number 4 for fuel transfer.
- 27 Fuel transfer isolation valve port tank 3 (27). Valve to open or close the port fuel tank number 3 for fuel transfer.
- 28 Sea chest blowdown vent (28). Provides ventilation to the sea chest for ballast/deballast operations.

1-8. Equipment Data.

Length overall	174.00 feet
Length between perpendiculars	156.00 feet
Beam, maximum molded	42.00 feet
Depth, maximum molded	11.50 feet
Draft, maximum molded (maximum load)	8.85 feet
Lightship (approximately)	575 long tons
Full load displacement (approximately)	1,087 long tons
Ship brake horsepower	2,500 bhp
Speed, full load condition	10 knots (MCR)
Speed, deployment condition	12 knots
Minimum cruising radius	4,500 nautical miles



Cargo deck area		100 feet by 38 feet
Maximum cargo load		350 short tons
Total Fuel Oil Capacity		92,243.9
F-3P	13,279	
F-3S	13,279	
F-4P	20,568	
F-4S	20,568	
F-7P	10,065	
F-7S	10,065	
F-DAY-12P	2,056	
F-DAY-12S	2,056	
Bowthruster	234.6	
Emergency generator	73.3	
Total potable water capacity		4,618 gallons
FW6P	2,309	
FW6S	2,309	
Foam concentrate capacity		695 gallons
Sludge oil capacity		1,343 gallons
Dirty oil capacity		1,197 gallons
Lube oil capacity		444 gallons
Hydraulic oil capacity		790 gallons
Total salt water capacity		123,171 gallons
SW-1CL	11,649	
SW-2P	14,148	
SW-2S	14,148	
SW-5P	34,303	
SW-5S	34,303	
SW-8P	7,310	
SW-8S	7,310	
Crew (except LCU 2008, 9, 10, 11, 12)	2 officers, 1 enlisted	
Crew (LCU 2008, 9, 10, 11, 12 only)	2 officers, 14 enlisted, 1 corpsman	

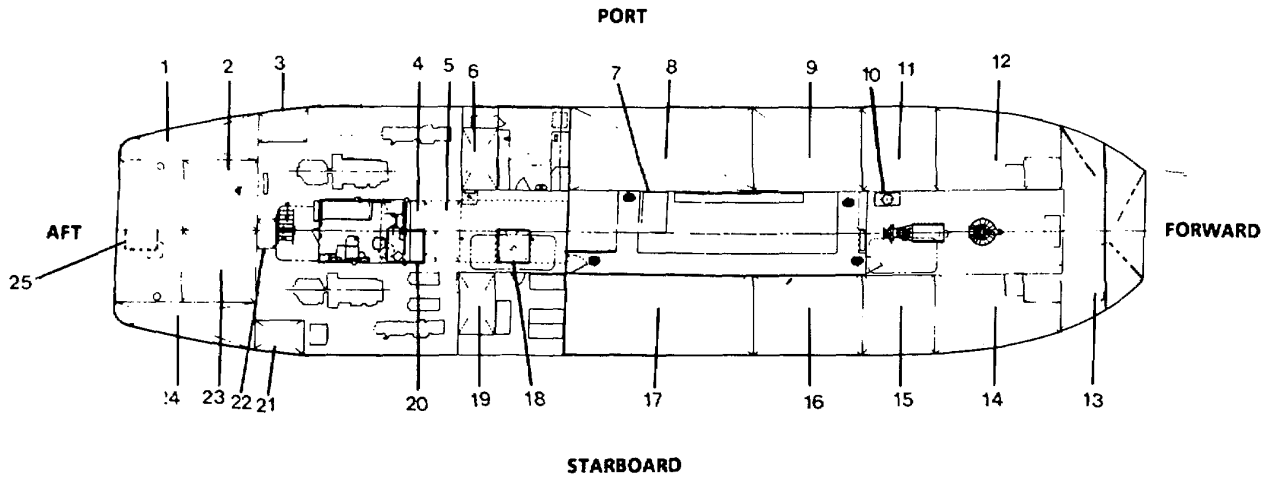

**LEGEND**

- |  |   |
|--|---|
| <ul style="list-style-type: none"> <li>1. SEA WATER BALLAST SW-8P</li> <li>2. FUEL F-7P</li> <li>3. MN ENG DAY TANK F DAY 12P</li> <li>4. SLUDGE</li> <li>5. DIRTY OIL</li> <li>6. FRESHWATER FW-6P</li> <li>7. HYDRAULIC OIL</li> <li>8. SEA WATER BALLAST SW-5P</li> <li>9. FUEL F-4P</li> <li>10. BOWTHRUSTER DAY TANK</li> <li>11. FUEL F-3P</li> <li>12. SEA WATER BALLAST SW-2P</li> <li>13. SEA WATER BALLAST SW-1CL</li> </ul> | <ul style="list-style-type: none"> <li>14. SEA WATER BALLAST SW-2S</li> <li>15. FUEL F-3S</li> <li>16. FUEL F-4S</li> <li>17. SEA WATER BALLAST SW-5S</li> <li>18. FOAM</li> <li>19. FRESH WATER FW-6S</li> <li>20. SEA CHEST</li> <li>21. MN ENG DAY TANK F DAY-12S</li> <li>22. LUBE OIL LO-13</li> <li>23. FUEL F-7S</li> <li>24. SEA WATER BALLAST SW-8S</li> <li>25. EMERGENCY GEN DAY TANK</li> </ul> |
|--|---|

FIGURE 1-28. Tank Locations.

1-71/(1-72 blank)

### Section III. TECHNICAL PRINCIPLES OF OPERATION

1-9. **General.** The following paragraphs provide technical principles of operation of the LCU systems.

1-10 **Power Generation System** The power generation system provides the LCU with primary (240 Vac, 3-phase, 60Hz 250kW) and emergency (240 Vac, 3-phase, 60Hz, 40kW) electrical power (FIGURE 1-29). Primary power is generated by one of two ship's service diesel generator (SSDG) sets, which supply the main switchboard and the emergency switchboard through a bus tie from the main switchboard. Emergency power is generated by an emergency diesel generator set, which supplies the emergency switchboard for continued operation of vital systems and equipment during loss of primary power. In port, the LCU is capable of receiving shore power (480/240 Vac) through a shore power cable terminating at a two-connection shore power box. If available shore power is 480 Vac, the power is selected at the main switchboard through a circuit breaker and stepped down to 240 Vac by three shore power transformers, prior to main switchboard entry. Shore power of 240 Vac is selected at the main switchboard by circuit breaker, and bypasses the 480 Vac transformers. Automatic bus transfer equipment, located in the emergency switchboard, isolates the emergency switchboard from the main switchboard upon loss of primary power and allows emergency power to be supplied through the emergency switchboard.

a. Ship's Service Diesel Generator Engine Two diesel generator set engines power individual ship's service generators, which provide primary electrical power throughout the LCU. The port ship's service diesel generator engine (No. 2) is air started; the starboard ship's service diesel generator engine (No. 1) is electrically started. Engine control and monitoring are provided from the engine room soncole and at the individual engine control panel.

b. Ship's Service Generator Two 250kW brushless exciter generators provide 240 Vac, three-phase, 60 Hz primary ship's service power. The output leads on the generator are in the low "Y" configuration, (see FIGURE 1-29A). A center ground lead is not used. Each generator is capable of providing 110 percent of the necessary at sea load for the propulsion and safety of the ship under normal conditions. The generators may be operated in parallel; however, normal operation has one generator on line and the other in reserve.

c. Main Switchboard The main switchboard (FIGURE 1-30), located in the engine room operating station, provides generator selection, shore power selection, and power distribution for ship's service 240 Vac and 120 Vac power. Distribution of 120 Vac is accomplished by ship's service 120 Vac isolation transformer located in the engine room operation station. The emergency switchboard bus tie provides 240 Vac to the emergency switchboard. Power selection is provided by closing circuit breakers on the switchboard. Power monitoring is provided by ammeters, voltmeters, frequency meters, and synchronization meters. Controls are provided for manual and automatic generator voltage regulation and generator engine speed regulation. The switchboard bus tie also serves as an emergency 240 Vac power feedback source for the main switchboard from the emergency switchboard, to power selected equipment systems during emergency power conditions. An interlock system is incorporated into the switchboard to prevent shore power from being applied to the switchboard while generator power is applied. The interlock system also prevents the emergency switchboard emergency generator circuit breaker from being closed.

d. Emergency Switchboard The emergency switchboard (FIGURE 1-31), located in the emergency generator room, normally receives 240 Vac primary power from the main

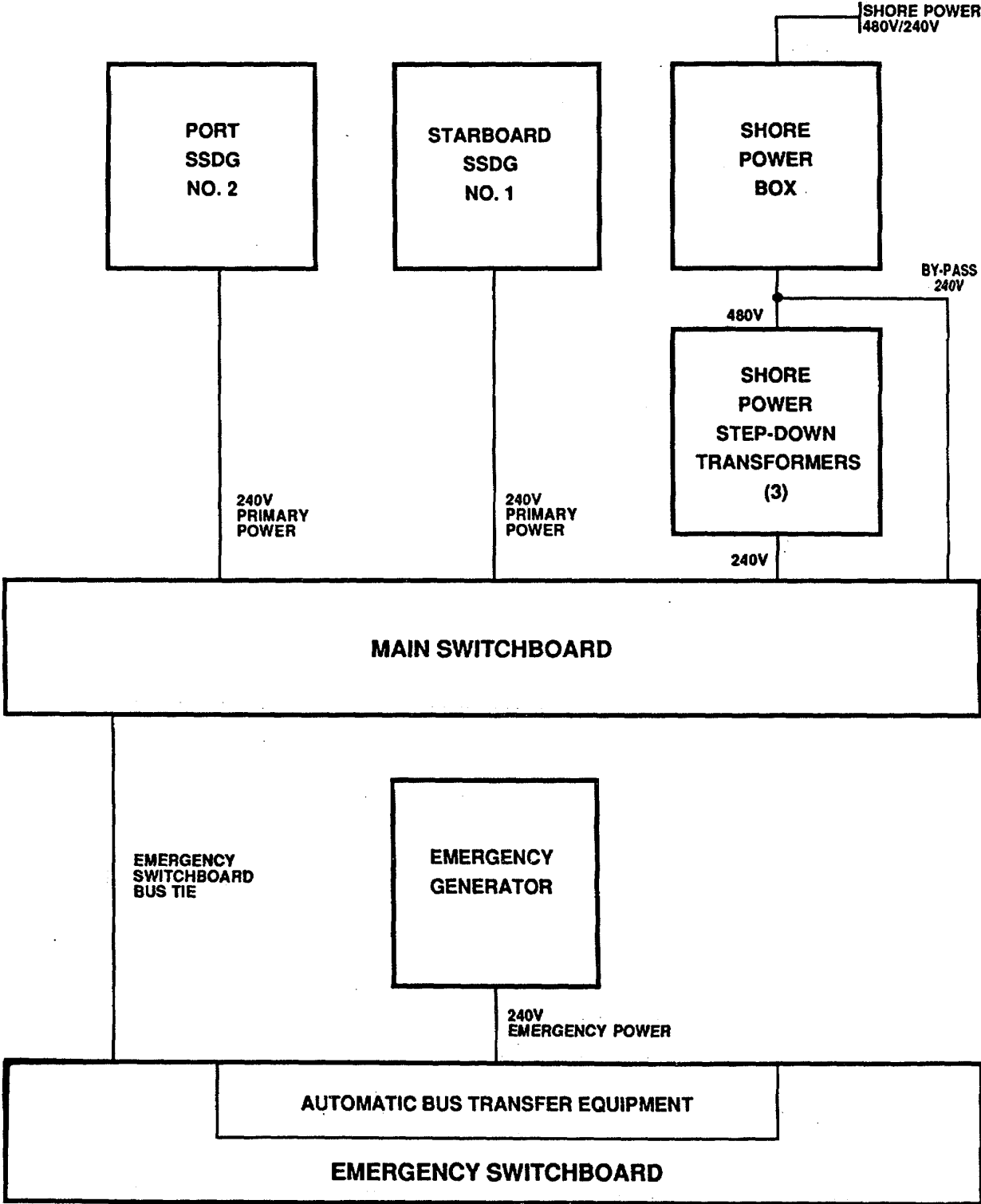

FIGURE 1-29. Power Generation System.

Low Y Output Voltage Adjustment range:  
60 Hz: 190A -240, volt

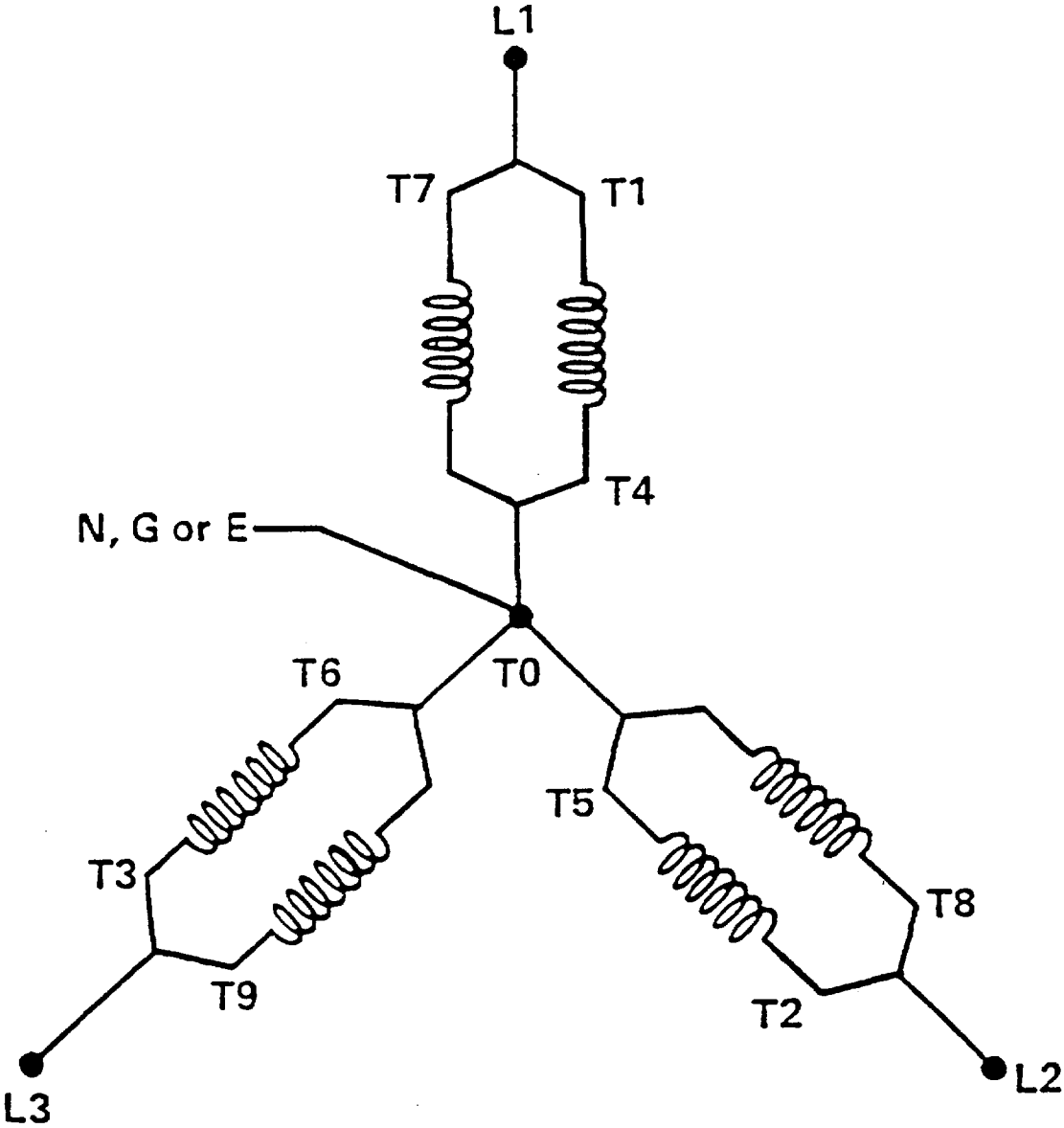

FIGURE 1-29A. OUTPUT LEADS ON THE SHIPS SERVICE GENERATOR IN THE LOW Y POSITION.

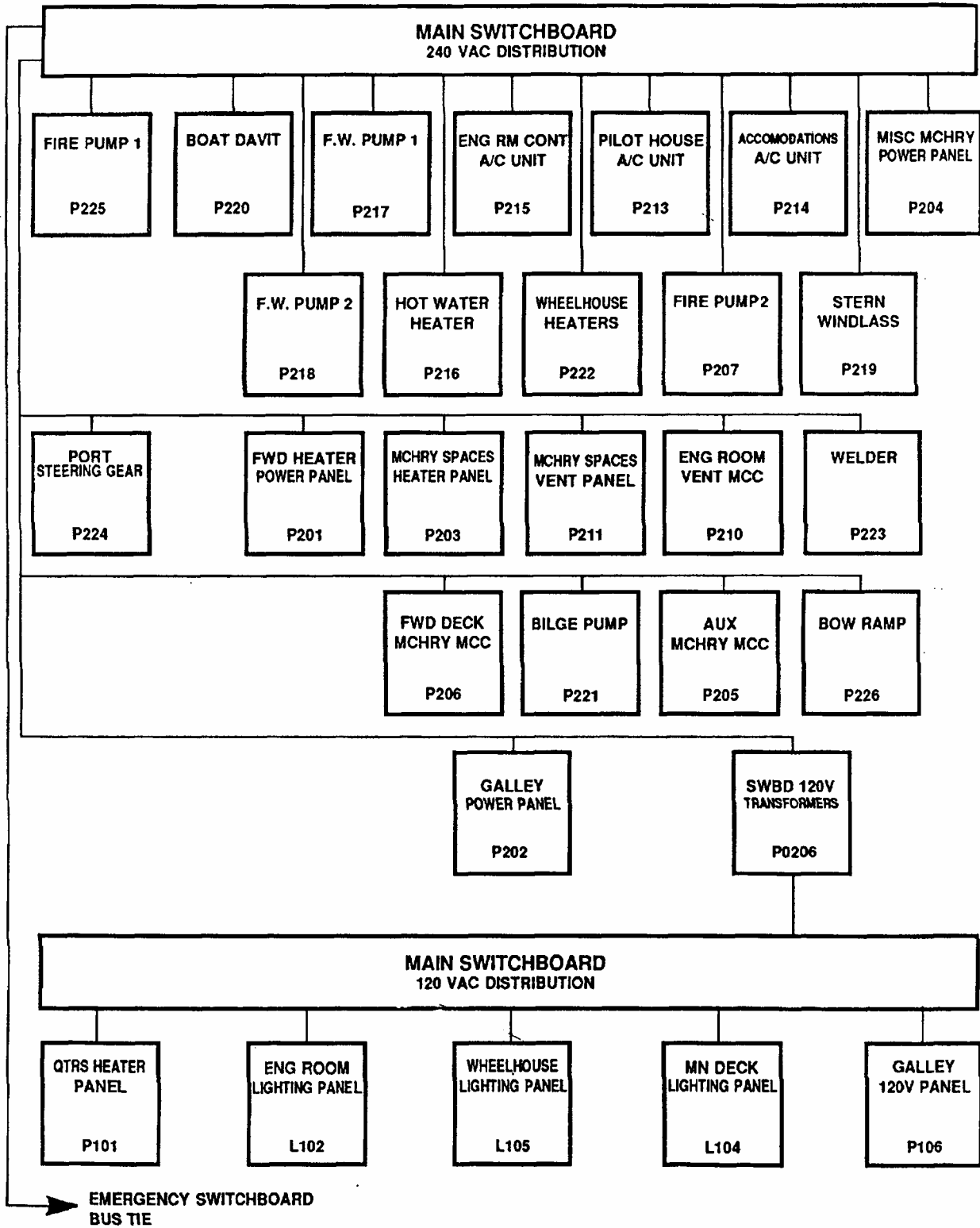

FIGURE 1-30. Main Switchboard

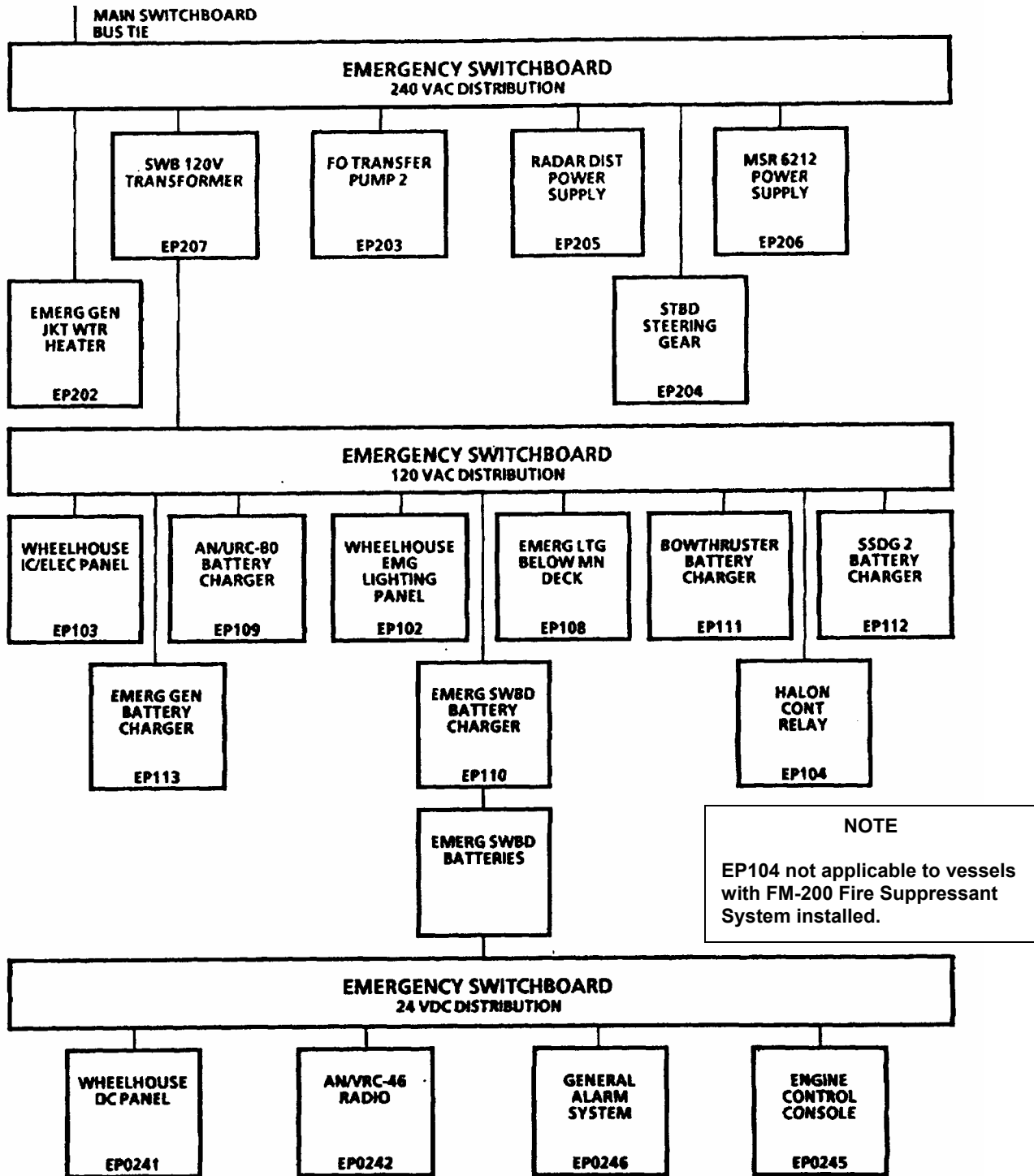

FIGURE 1-31. Emergency Switchboard

switchboard through the bus tie. Upon loss of ship's service power from the main switchboard, automatic bus transfer equipment within the emergency switchboard isolates the emergency switchboard and provides for automatic or manual starting of the emergency generator. Power monitoring of the emergency generator is provided by a voltmeter, ammeter, watt meter, and frequency meter. A voltage adjustment control for the emergency generator output is also provided. A main switchboard bus tie circuit breaker and bus tie bypass switch permit distribution of emergency power (240 Vac) to the main switchboard. The emergency generator circuit breaker is prevented from being closed by an interlock system when primary power is being provided through the bus tie. Power distribution is accomplished through circuit breakers on the switchboard 240 Vac, 120 Vac, and 24 Vdc distribution panels. A step-down transformer provides 120 Vac back to the switchboard, and a 24 Vdc battery charger and switchboard batteries provide 24 Vdc back to the switchboard for distribution.

e. Emergency Diesel Generator Engine The emergency diesel generator set engine powers the emergency generator. The engine is completely independent, and has its own lubrication oil and cooling systems. The engine is electrically started. Switchboard automatic bus transfer equipment automatically starts the engine upon failure of the ship's service systems.

f. Emergency Generator The emergency generator provides power to the emergency switchboard within 45 seconds of a ship's service power systems failure. One 40 kW generator provides emergency power.

g. Shore Power Box The shore power box is located on the 01 level, aft exterior bulkhead. The two-connection shore power box provides a cable connection for shore power and another cable connection for providing shore power to another vessel in tandem.

1-11. **Environmental Control System** This system provides the LCU living compartments and specified work spaces with air conditioning and heating. Other work spaces and storage spaces are provided with forced air ventilation and heating and natural supply and exhaust ventilation.

a. Pilothouse Deck (02 Level).The pilothouse deck contains the following heating, ventilation, and air conditioning (HVAC) equipment (FIGURE 1-32, Sheet 1):

(1) Engine room exhaust fan EF-1 (1) An axial fan with electric motor direct drive that provides forced air ventilation for the engine room port side by drawing up through the stack.

(2) Galley exhaust fan EF-6 (2). A centrifugal fan with electric motor V-belt drive that provides forced air ventilation for the galley. Air is drawn up from the galley hood.

(3) Pilothouse duct heater DH-2 (3) A duct mounted, flanged type, electric heater that provides heat for the pilothouse. The thermostat for the pilothouse duct heater is located on the overhead in the stairway.

(4) Pilothouse air conditioning unit AC-2 (4) A self-contained, 3-ton capacity air conditioner that provides air conditioning to the pilothouse.



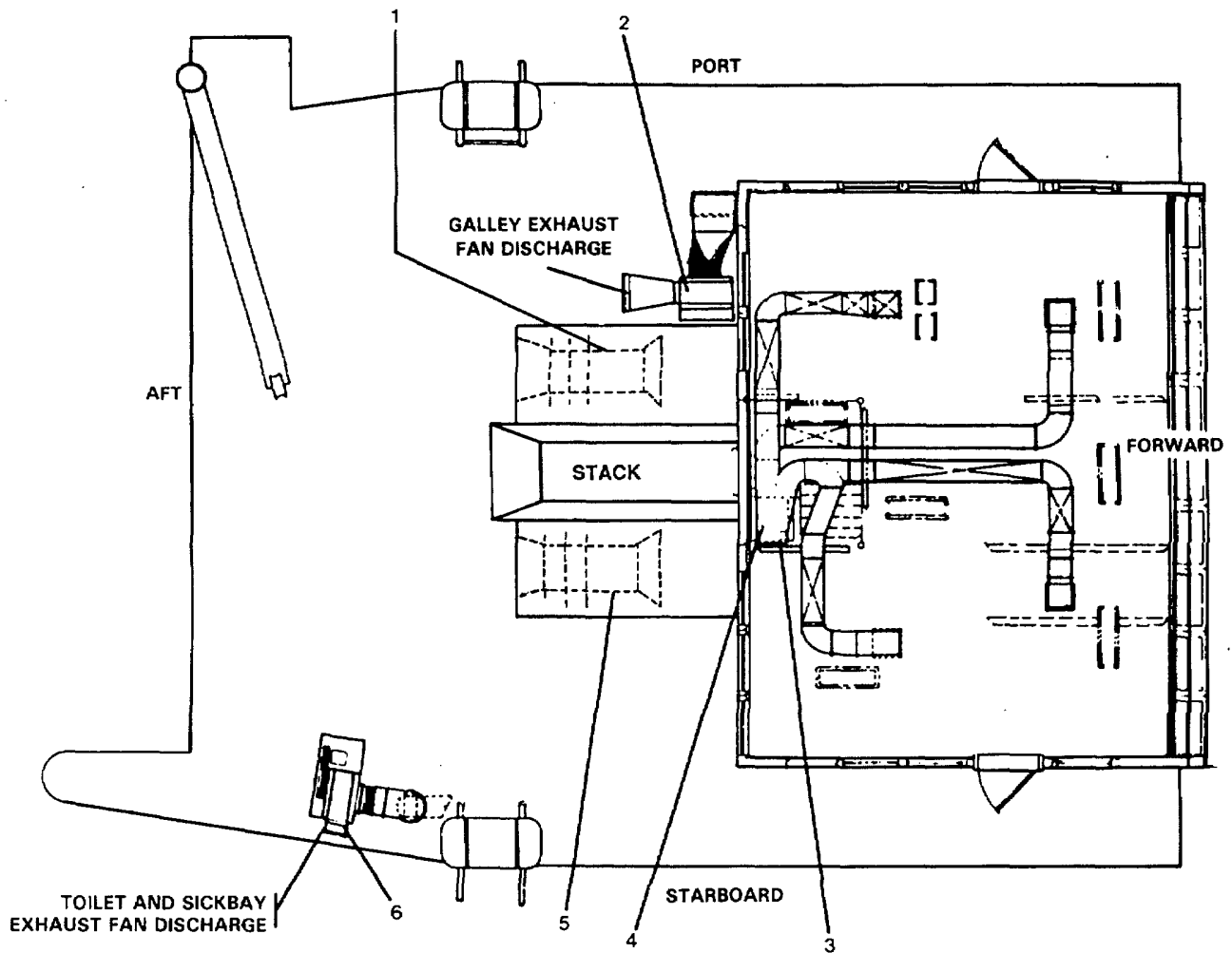

**LEGEND**

- |                                 |  |
|---------------------------------|--|
| 1. ENGINE ROOM EXHAUST FAN EF-1 | 4. PILOTHOUSE AIR CONDITIONING UNIT AC-2 |
| 2. GALLEY EXHAUST FAN EF-6      | 5. ENGINE ROOM EXHAUST FAN EF-2          |
| 3. PILOTHOUSE DUCT HEATER DH-2  | 6. TOILET AND SICKBAY EXHAUST FAN EF-4   |

FIGURE 1-32. Pilothouse Deck (02 Level) HVAC Equipment (Sheet 1 of 6).

(5) Engine room exhaust fan EF-2 (5) An axial fan with electric motor direct drive that provides forced air ventilation for the engine room starboard side by drawing up through the stack.

(6) Toilet and sick bay exhaust fan EF-4 (6) A centrifugal fan with electric motor V-belt drive that provides forced air ventilation for the main deck sick bay and toilet.

b. Accommodation Deck (01 Level). The accommodation deck contains the following HVAC equipment (FIGURE 1-32, Sheet 2):

(1) Duct heaters The duct heaters are duct mounted, flanged type, electric heaters. Duct heater DH-8 (7) provides heating for the aft port four-crew stateroom. Duct heater DH-7 (8) provides heating for the port three-crew stateroom. Duct heater DH-6 (9) provides heating for the port two-crew stateroom. Duct heater DH-5 (10) provides heating for the port forward two-crew stateroom. Duct heater DH-4 (11) provides heating for the chief engineer's stateroom. Duct heater DH-10 (13) provides heating for the master's stateroom. Duct heater DH-9 (16) provides heating for the laundry room. A thermostat for each duct heater is located in the compartment served.

(2) Convection heaters The convection heaters are convection type electric space heaters. Convection heater CH-3 (12) provides heating for the master and chief engineer's toilet. Convection heater CH-2 (14) provides heating to the forward crew toilet. Convection heater CH-1 (15) provides heating to the aft crew toilet. A thermostat for each convection heater is located on the unit.

(3) Natural ventilation Ventilation louvers installed in doors provide natural exhaust ventilation for each compartment on the accommodation deck.

(4) Air conditioning Air conditioning is furnished by a 17-ton capacity air conditioner assembly. Air conditioning for the accommodation deck is provided by air conditioning unit AC-1 located in the emergency generator room. Conditioned air is forced through ducting to all compartments.

c. Main Deck Aft. The main deck aft contains the following HVAC equipment (FIGURE 1-32, Sheet 3):

(1) Galley makeup air supply fan SF-6 (17) The galley makeup air supply fan SF-6 is an axial fan with electric motor V-belt drive. The fan provides forced inlet makeup air for the galley.

(2) Galley makeup air duct heater DH-3 (18) The galley makeup air duct heater DH-3 is a duct mounted, flanged type, individually fused, electric heater which provides heating for galley makeup air. A control panel for the heater is located on the forward port bulkhead of the provisions storeroom.

(3) Provisions storeroom duct heater DH-13 (19) Duct heater DH-13 is a duct mounted, flanged type, electric heater which provides heating for the provisions storeroom.

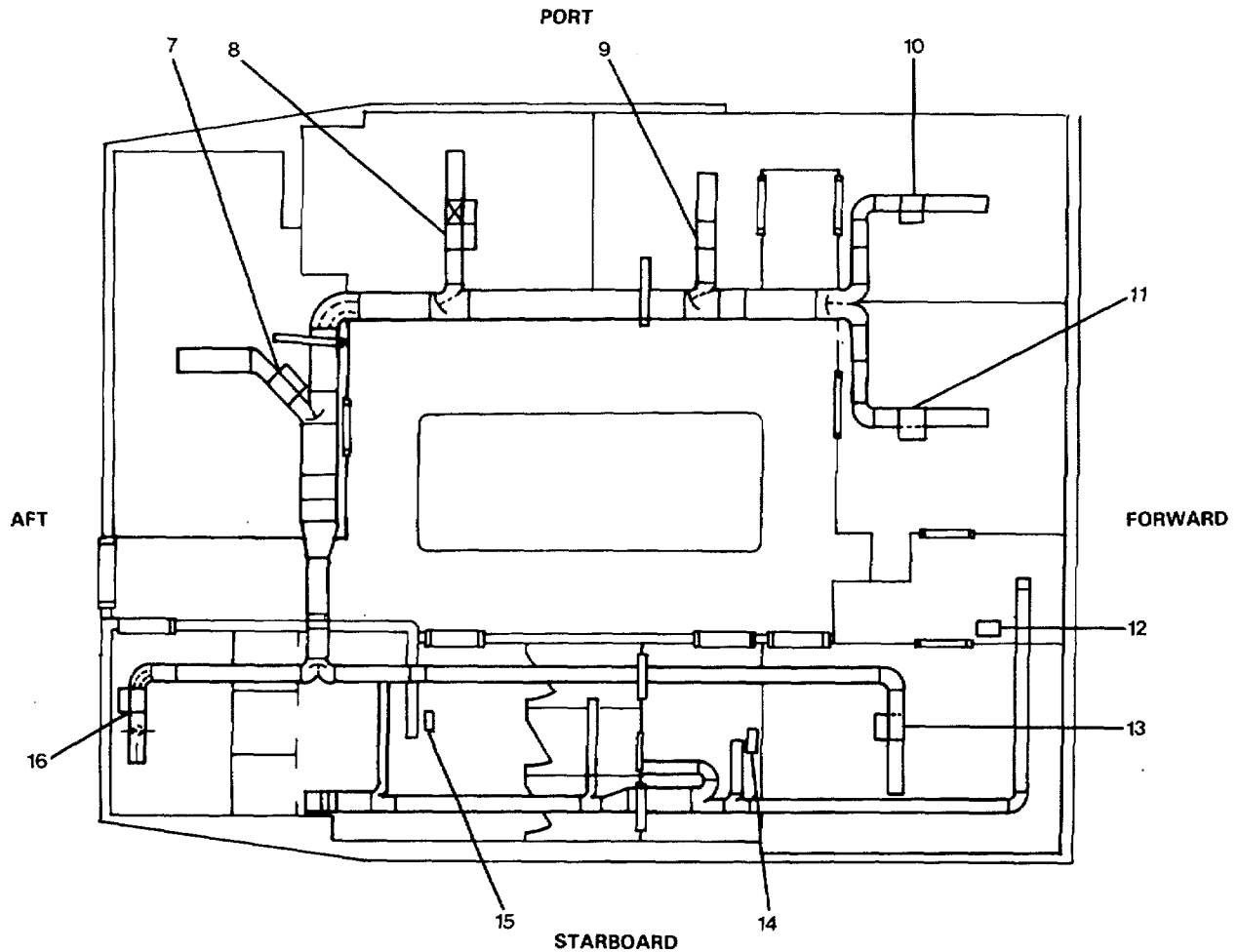

**LEGEND**

- |   |  |
|---|--|
| 7. CREW STATEROOM DUCT HEATER DH-8                                | 13. MASTER STATEROOM DUCT HEATER DH-10       |
| 8. CREW STATEROOM DUCT HEATER DH-7                                | 14. CREW WATER CLOSET CONVECTION HEATER CH-2 |
| 9. CREW STATEROOM DUCT HEATER DH-6                                | 15. CREW WATER CLOSET CONVECTION HEATER CH-1 |
| 10. CREW STATEROOM DUCT HEATER DH-5                               | 16. LAUNDRY DUCT HEATER DH-9                 |
| 11. CHIEF ENGINEER'S STATEROOM DUCT HEATER DH-4                   |  |
| 12. MASTER & CHIEF ENGINEER'S WATER CLOSET CONVECTION HEATER CH-3 |  |

FIGURE 1-32. Accommodations Deck (01 Level) HVAC Equipment (Sheet 2 of 6).

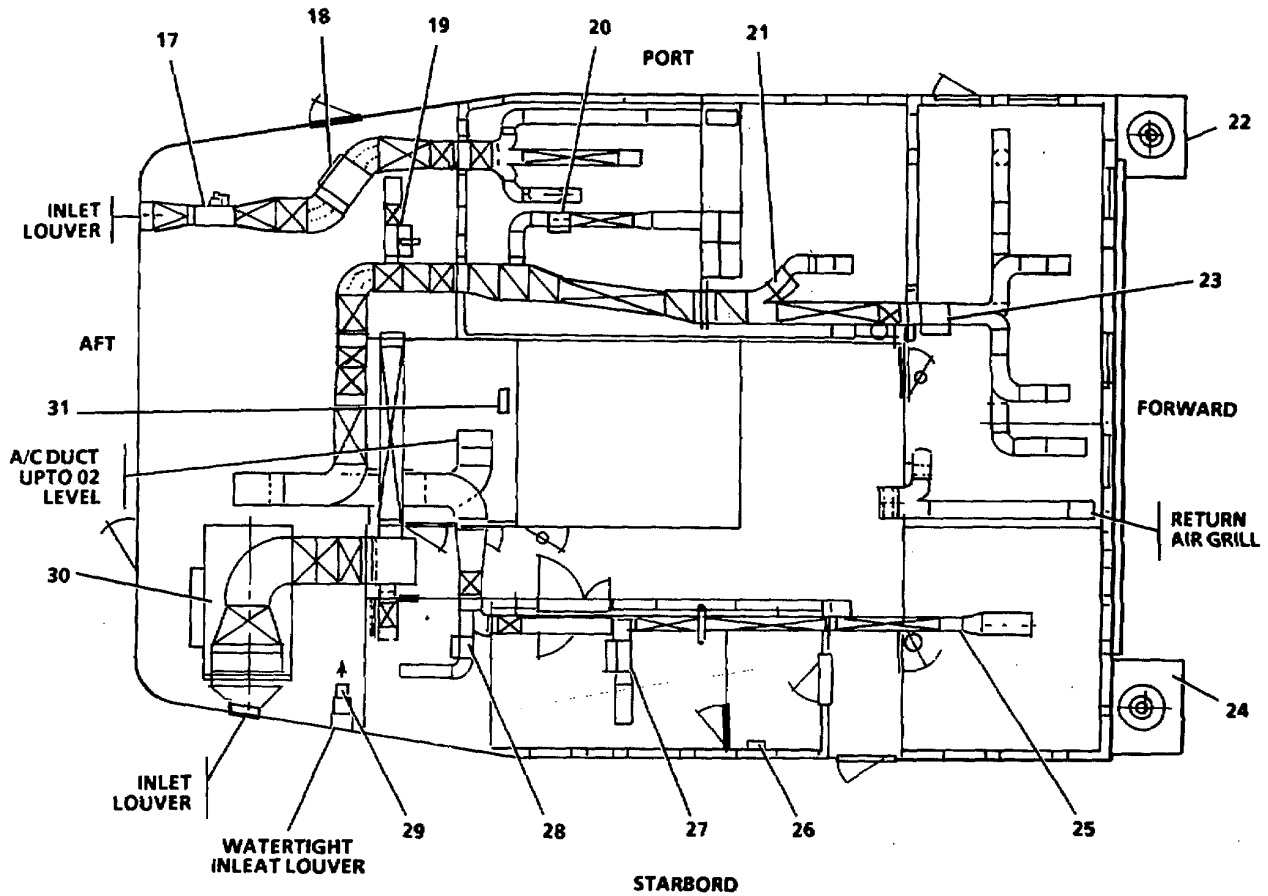

**LEGEND**

- |  |   |
|--|---|
| 17. GALLEY MAKE UP AIR SUPPLY FAN SF-6     | 25. RECREATION ROOM DUCAT HEATER DH-16            |
| 18. GALLEY MAKE UP AIR DUCT HEATER DH-3    | 26. DECK/SICK BAY WATER CONVECTION HEATER CH-14   |
| 19. PROVISIONS STOREROOM DUCT HEATER DH-13 | 27. SICK BAY DUCT HEATER DH-15                    |
| 20. GALLEY DUCT HEATER DH-12A              | 28. ARMS CONTROL ROOM DUCT HEATER DH-14           |
| 21. GALLEY DUCT HEATER DH-12               | 29. EMERGENCY GENERATOR ROOM SUPPLY FAN SF-5      |
| 22. ENGINE ROOM SUPPLY FAN SF-1            | 30. MAIN ACCOMMODATION AIR CONDITIONING UNIT AC-1 |
| 23. MESS ROOM DUCT HEATER DH-11            | 31. EMERGENCY GENERATOR ROOM UNIT HEATER UH-6     |
| 24. ENGINE ROOM SUPPLY FAN SF-2            |   |

FIGURE 1-32. Main Deck Aft HVAC Equipment (Sheet 3 of 6).

- (4) Galley duct heater DH-12A (20).Galley duct heater DH-12A is a duct mounted, flanged type, electric heater which provides heating for the aft galley area.
- (5) Galley duct heater DH-12 (21).Galley duct heater DH-12 is a duct mounted, flanged type, electric heater which provides heating for the forward galley area.
- (6) Engine room supply fan SF-1 (22)Engine room supply fan SF-1 is an axial fan with electric motor direct drive which provides forced supply air for the engine room port side. The fan is enclosed in a watertight enclosure on the lower main weather deck port side.
- (7) Mess room duct heater DH-11 (23).Mess room duct heater DH-11 is a duct mounted, flanged type, electric heater which provides heating for the mess room.
- (8) Engine room supply fan SF-2 (24)Engine room supply fan SF-2 is an axial fan with electric motor direct drive which provides forced supply air for the engine room starboard side. The fan is enclosed in a watertight enclosure on the lower weather main deck starboard side.
- (9) Recreation room duct heater DH-16 (25).The recreation room duct heater DH-16 is a duct mounted, flanged type, electric heater which provides heating for the recreation room.
- (10) Deck/sick bay toilet convection heater CH-14 (26).The deck/sick bay toilet convection heater CH-14 is a convection type electric space heater provides heating for the main deck/sick bay toilet.
- (11) Sick bay duct heater DH-15 (27).The sick bay duct heater DH-15 is a duct mounted, flanged type, electric heater which provides heating for the sick bay.
- (12) Arms control room duct heater DH-14 (28).The arms control room duct heater DH-14 is a duct mounted, flanged type, electric heater which provides heating for the arms control room.
- (13) Emergency generator room supply fan SF-5 (29)The emergency generator room supply fan SF-5 is a panel fan with electric motor direct drive provides forced supply air to the emergency generator room, drawn in from a watertight, bolted-on inlet louver on the starboard bulkhead.
- (14) Main accommodation air conditioning unit AC-1 (30)The accommodation air conditioning unit AC-1 is a 16-ton capacity air conditioner assembly located in the emergency generator room. The unit provides conditioned air to all accommodations rooms on the 01 level (FIGURE 1-32, Sheet 2) as well as those rooms indicated on the main deck (FIGURE 1-32, Sheet 3).
- (15) Emergency generator room unit heater UH-6 (31)Unit heater UH-6 is a forced air, electric space heater which provides heating for the emergency generator room.

(16) Ventilation Forced ventilation for the deck/sick bay toilet is provided by ducting up to the pilothouse deck toilet and sick bay exhaust fan EF-4 (FIGURE 1-32, Sheet 1). Natural inlet ventilation is provided by through-door louvers on the deck/sick bay and galley passageway doors. Natural exhaust ventilation is provided by through-door louvers on the remaining passageway doors.

d. Main Deck Forward The forward main deck space contains the following heating and ventilation equipment (FIGURE 1-32, Sheet 4):

(1) Paint locker exhaust fan EF-7 (32) Exhaust fan EF-7 is a centrifugal fan with an "explosion proof" electric motor V-belt drive which provides forced air exhaust for the paint locker room.

(2) Paint locker unit heaters UH-8 (33) and UH-8A (34) Unit heaters UH-8 and UH-8A are forced air, electric space heaters with "explosion proof" motors that provide heating to the paint locker room.

(3) Boatswain storeroom unit heater UH-7 (35) Unit heater UH-7 is a forced air, electric space heater that provides heating to the boatswain storeroom.

(4) Ventilation. Ventilation of the paint locker room is provided by screened and watertight inlet and exhaust louvers on the forward and aft inboard bulkhead. Ventilation of the boatswain storeroom is provided by screened and watertight inlet and exhaust louvers on the forward inboard bulkhead and aft bulkhead, respectively.

e. Below Main Deck Aft Spaces situated below the main deck aft are equipped with the following HVAC equipment (FIGURE 1-32, Sheet 5):

(1) Steering gear room unit heater UH-3 (36) Unit heater UH-3 is a forced air electric space heater that provides heating to the steering gear room.

(2) Steering gear room exhaust fan EF-3 (37) Exhaust fan EF-3 is an axial fan with electric motor direct drive that provides forced air exhaust ventilation for the steering gear room.

(3) Engine room operating station duct heater DH-17 (38) Duct heater DH-17 is a duct mounted, flanged type, electric heater that provides heating for the engine room operating station.

(4) Engine room unit heater UH-2 (39) Unit heater UH-2 is a forced air electric space heater that provides heating to the engine room port side.

(5) Machine shop supply air fan SF-1 (40) Supply air fan SF-1 is an axial fan with electric motor direct drive that provides forced supply air from a gooseneck ventilator located on the main deck. Forced supply air is provided through ducting to the machine shop, tool locker, tunnel, storeroom, and engine room operating station.

(6) Machine shop unit heater UH-9 (41) Unit heater UH-9 is a forced air electric space heater that provides heating to the machine shop and tool room.

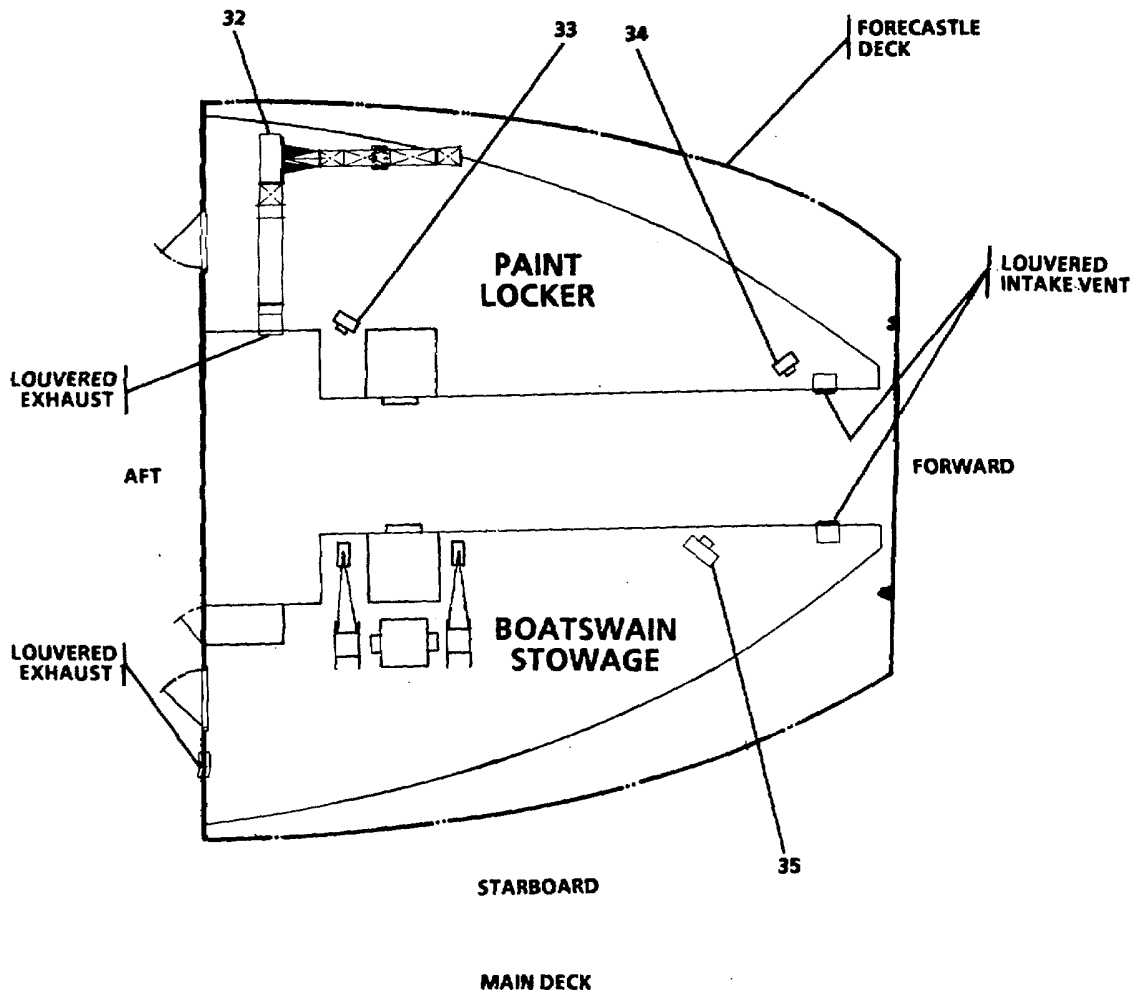

**LEGEND**

- 32. PAINT LOCKER EXHAUST FAN EF-7
- 33. PAINT LOCKER UNIT HEATER UH-8

- 34. PAINT LOCKER UNIT HEATER UH-8A
- 35. BOATSWAIN STOREROOM UNIT HEATER UH-7

FIGURE 1-32. Main Deck Forward HVAC Equipment (Sheet 4 of 6).

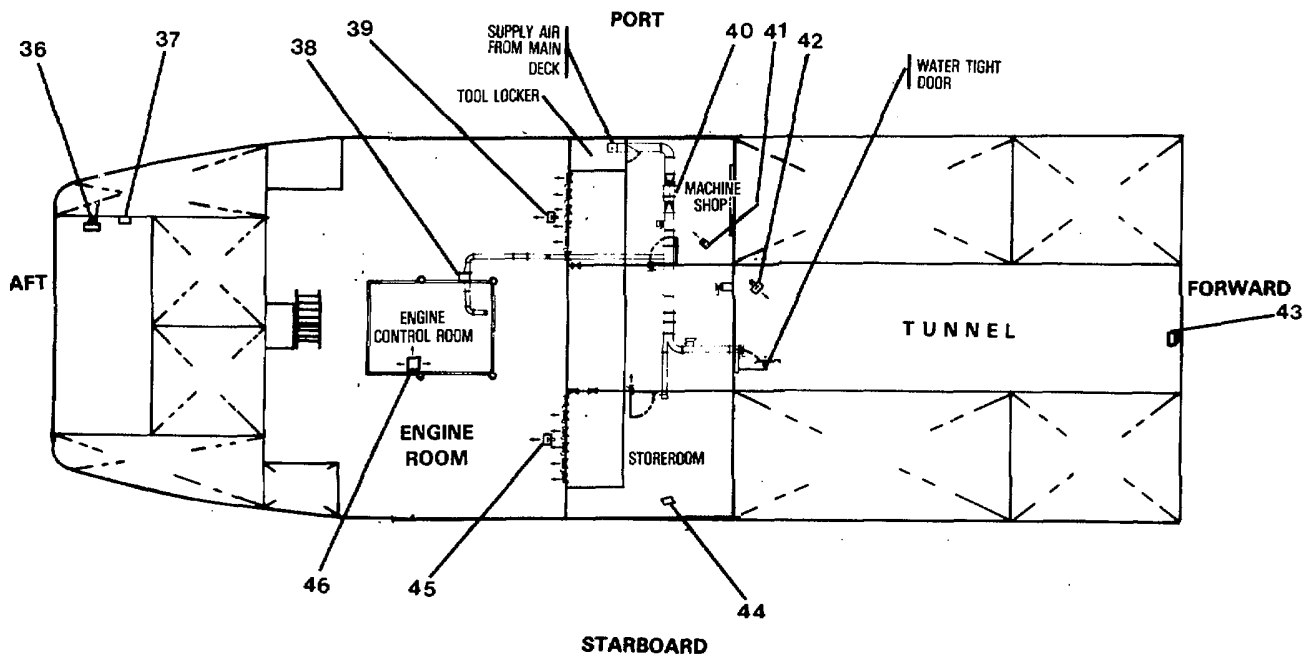

**LEGEND**

- |   |  |
|---|--|
| 36. STEERING GEAR ROOM UNIT HEATER UH-3   | 42. TUNNEL UNIT HEATER UH-10                       |
| 37. STEERING GEAR ROOM EXHAUST FAN EF-3   | 43. TUNNEL UNIT HEATER UH-4                        |
| 38. ENGINE CONTROL ROOM DUCT HEATER DH-17 | 44. STOREROOM UNIT HEATER UH-11                    |
| 39. ENGINE ROOM UNIT HEATER UH-2          | 45. ENGINE ROOM UNIT HEATER UH-1                   |
| 40. MACHINE SHOP SUPPLY AIR FAN SF-1      | 46. ENGINE CONTROL ROOM AIR CONDITIONING UNIT AC-3 |
| 41. MACHINE SHOP UNIT HEATER UH-9         |  |

FIGURE 1-32. Below Main Deck Aft HVAC Equipment (Sheet 5 of 6).



(7) Tunnel unit heaters UH-10 (42) and UH-4 (43)Unit heaters UH-10 are forced air electric space heaters that provide heating to the aft and forward areas of the tunnel, respectively.

(8) Storeroom unit heater UH-11 (44).Unit heater UH-11 is a forced air electric space heater that provides heating to the storeroom.

(9) Engine room unit heater UH-1 (45).Unit heater UH-1 is a forced air electric space heater that provides heating to the starboard side of the engine room.

(10) Engine room operating station air conditioning unit AC-3 (46)Air conditioning unit AC-3 is a self-contained, 3-ton capacity air conditioner that provides conditioned air to the engine room operating station only. Supply air for the self contained unit is provided through overhead ducting.

(11) Ventilation. Ventilation for the engine room is provided by the stack uptake. Engine room supply air is provided by supply fans SF-1 and SF-2 located on the main weather deck. Exhaust ventilation for the storeroom, tunnel, and machine shop is provided by watertight through-bulkhead vents with wire screens and shutoff dampers. Inlet ventilation for the tunnel is provided by a through-bulkhead vent with wire screen and shutoff damper.

f. Below Main Deck Forward The bowthruster room is located below the main deck forward and is provided with the following heating and ventilation equipment (FIGURE 1-32, Sheet 6):

(1) Bowthruster room unit heater UH-5 (48).Unit heater UH-5 is a forced air electric space heater that provides heating to the bowthruster room.

(2) Bowthruster room supply fan SF-4 (47)Supply fan SF-4 is an axial fan with electric motor V-belt drive that draws air in from the forecastle deck to the bowthruster room.

(3) Ventilation Ventilation for the bowthruster room is by natural exhaust ventilation through the boatswains storeroom door vent on the main weather deck.

g. Heating Three types of heating units are used on the LCU: duct heaters, unit heaters, and convection heaters.

(1) Duct heaters Duct heaters are flange type, installed in the ducting serving the pilothouse, 01 level, main deck, and engine room operating station.

(a) Duct heater DH-1. This heater is a Model TFZU, 19.1 kW type measuring 49.125 inches in width, and 23.875 inches in height. DH-1 is located inside the main accommodation air conditioning unit AC-1. The unit provides pre-heating for accommodation spaces on the 01 level and main deck. Outlet air from AC-1 flows over finned tubular electric heating elements aligned across the ducting leaving the air conditioning unit. The heater will not energize without fan air flowing across the heating elements. Setting the thermostat to a temperature above ambient will turn the air conditioner fan and duct heater on. The duct heater cannot be energized while in the air conditioning (cooling) mode of operation.

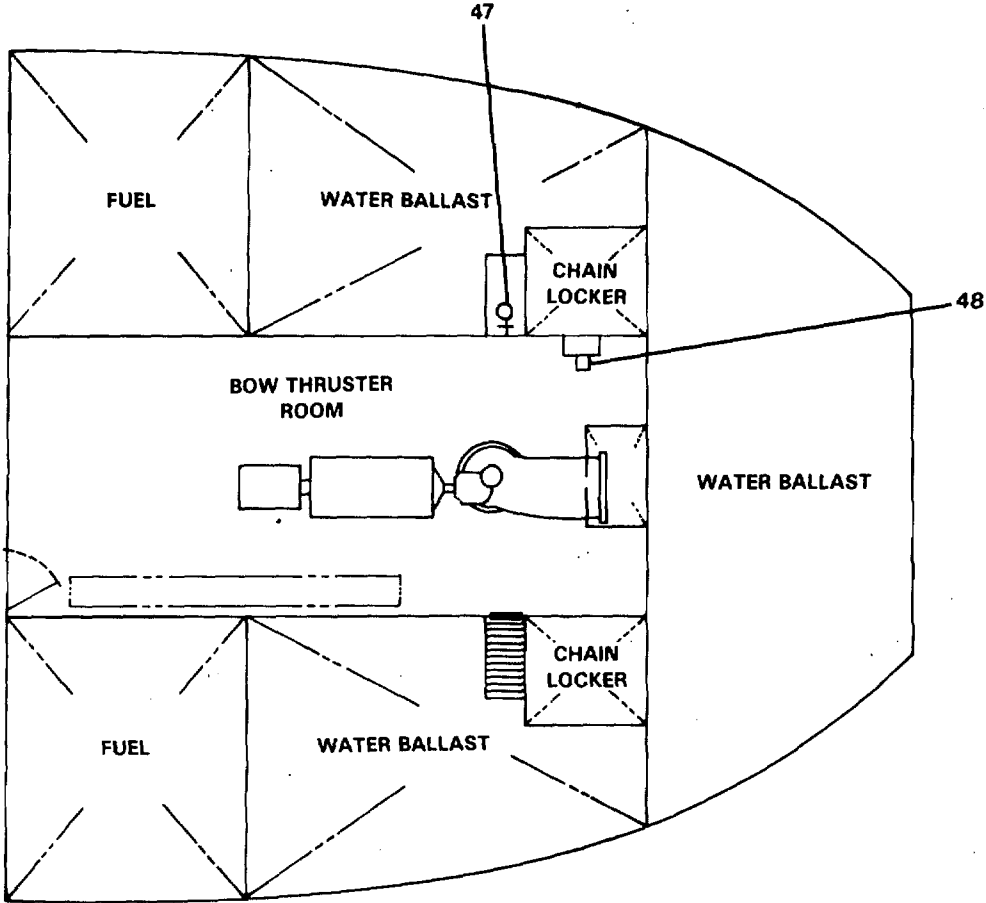

**LEGEND**  
48. BOWTHRUSTER ROOM UNIT HEATER UH-5  
47. BOWTHRUSTER ROOM SUPPLY FAN SF-4

FIGURE 1-32. Below Main Deck Forward HVAC Equipment (Sheet 6 of 6).

(b) Duct heater DH-2. DH-2 is a Model CHMS-3-F, flanged metal sheath element type utilizing fins for heat transfer. DH-2 is located in the ducting just above air conditioning unit AC-2 in the pilot house. Fan air from the air conditioning unit flows over the heating elements which heat the air. This unit provides heating to the pilot house. Air must be forced over the heating elements before they can be energized. The thermostat for DH-2 is located overhead in the stairway. A metal door on the unit can be opened to provide access to controls.

(c) Duct heater DH-3. This unit is a Model CHMS-3-F, three stage type. Three stages of heating elements, each controlled by a separate thermostat mounted in the provisions storeroom, control temperature of this heater. DH-3 serves as a preheater for the galley areas and provisions storeroom.

(d) Duct heaters DH-4 through DH-17. Each of these duct heaters is a Model CHMS-3-F. Wattage ratings vary from heater to heater. Heaters are installed in the ducting according to FIGURE 1-12, and are controlled by thermostats located in the space they serve.

(2) Unit heaters. Three types of unit heaters are utilized on the LCU: horizontal, waterproof horizontal, and explosion proof horizontal.

(a) Horizontal model LUH-B-15-23-34-40. UH-1 and UH-2 are 15 kW units mounted overhead and forward in the engine room. These are flameless fan-forced types with a spiral metal sheath fintube electric heating element with built-in overheat protection. Individual adjustable discharge louvers direct air flow. These units are temperature controlled from separately mounted thermostats.

(b) Horizontal model LUH-B-10-23-34-40. UH-4 and UH-10 are 10 kW units located in the tunnel. Each unit is identical to UH-1 and UH-2 except for wattage rating.

(c) Horizontal model LUH-B-5-23-34-40. UH-9 and UH-11 provide heat to the machine shop and engineer's storeroom and are 5 kW models. These heaters contain controls for on/off, LO and HI settings for temperature on the front panel. The LO setting is approximately 40°F and the HI setting is approximately 90°F.

(d) Waterproof horizontal model 234-U11N-0100K-3090. UH-3 and UH-5 are 10 kW types used in areas where moisture is present (steering gear room and bowthrustrer room). These units are overhead mounted and contain temperature and on/off controls. Adjustable louvered outlet grills may be rotated 90" to direct air flow up, down, left, or right. An adjustable temperature knob provides a 40°-100°F temperature range. A three-position control switch provides for heater on, heater standby, and fan only operation. A red indicator lamp labeled HEATER ON will light when heating elements are energized. UH-6 is the same type except it is a Model 234-UIIN-0050K-3092, 5 kW type.

(e) Explosion proof horizontal model 236-F015-0052K-4087. UH-8 and UH-8A (paint locker) are explosion proof 5 kW types. These units are overhead mounted, operable in areas where maximum ambient temperature is 80°F. Each heater is controlled by a single externally mounted thermostat. A built-in time delay relay allows the fan to continue to run for about 1 minute after the heater elements are switched off, in order to cool the elements.

(3) Convection heaters One 1 kW convection heater (CH-1) and three 0.5 kW convection heaters (CH-2, CH-3, and CH-4) are installed on the LCU. CH-1 is a Model DFM 11.0-1 and CH-2 through CH-4 are Model DFM 10.5-1. Each is a reflecting type bulkhead mounted heating unit. Each unit is equipped with an on/off switch, a temperature controlling thermostat knob, and a manual high limit reset pushbutton switch. The high limit thermostat is set to open at 350°F and close at 190°F when reset.

h. Ventilation In addition to forced supply air provided to accommodation compartments by the fan in air conditioning unit AC-1 and ducting, specified areas of the LCU are provided with forced air ventilation. The LCU compartments provided with only forced air ventilation are:

(1) 01 Level The 01 level main toilet and sick bay rooms are provided exhaust ventilation by toilet and sick bay exhaust fan EF-4 located on the pilothouse deck (02 level).

(2) Main deck The paint locker room is ventilated by exhaust fan EF-7. The galley is supplied with forced supply air by supply fan SF-6 and ventilated through the galley hood by exhaust fan EF-6 located on the pilothouse deck (02 level). The emergency generator room is provided forced supply air by supply fan SF-5.

(3) Below main deck The engine room is provided forced supply air by supply fans SF-2 (port) and SF-1 (starboard) located on the main weather deck. Forced air ventilation for the engine room is provided by exhaust fans EF-2 (port) and EF-1 (starboard) located in the stack on the pilothouse deck (02 level). The machine shop, tool locker, storeroom, engine room operating station, and tunnel receive forced supply air from supply fan SF-3 located in ducting in the machine shop area. The bowthruster room is provided forced supply air by supply fan SF-4 located in the bowthruster room. The steering gear room is provided forced air ventilation by exhaust fan EF-3 located in the steering gear room.

i. Air Conditioning Air conditioning is provided by the accommodation air conditioner AC-1, pilothouse air conditioner AC-2, and engine room operating station air conditioner AC-3.

(1) Accommodation air conditioner AC-1 AC-1 is a 15-ton, Model LSL-106 unit consisting of condenser, blower motor, and compressor with a nominal cooling capacity of 180,000 Btu at 40°F suction temperature and 110°F condensing temperature. Cooling air or air only is forced out by a belt driven blower motor via ducting to specified rooms and passageways of the 01 level and main deck. Return air is routed through door louvers and grills, bulkhead grills, passageways, and ducting back to the unit. Seawater is routed to the unit condenser to absorb heat given off by the system refrigerant and routed back out through the seawater discharge line. A seawater regulating valve automatically controls seawater flow through the condenser to maintain a relatively constant condensing pressure and temperature.

(2) Pilothouse air conditioner AC-2. AC-2 is a self-contained 3-ton, Model KC 33 D vertically mounted unit consisting of condenser, blower motor, and compressor with a nominal cooling capacity of 36,000 Btu. In the cooling mode of operation, refrigerant is directed from the compressor to the water-to-refrigerant condenser when the ambient temperature is above the external thermostat setting. Seawater is routed to the unit water inlet through a seawater regulating valve. The seawater

absorbs heat given off by the system refrigerant and is routed via the water outlet to the seawater discharge line. The unit is connected with flanged ducting to duct heater DH-2. A removable filter is installed on the starboard side of the unit. A condensate drain is routed out of the unit separately from the seawater discharge.

(3) Engine room operating station air conditioner AC-3AC-3 is identical to the AC-2, except that a plenum has been added on top of the unit for directing cooling air in three directions.

**1-12. Gyro Compass System** The gyro compass provides heading information to steering repeaters in the pilot house and steering gear room. The heading information is used for navigating the LCU. Heading data is also sent to bearing repeaters on the port and starboard bridge wings and the pilothouse top; to the radar direction finder, omega navigational receiver, X-band and S-band radar units; and to the autopilot. The gyro compass is provided with a viewing window and compass card (dial) for viewing ship's heading. The gyro control and power assembly provides for control and monitoring of the gyro compass and the routing of heading data. The outputs of the gyro compass, with the gyro control and power assembly repeater switch on, are applied to a switch unit. The switch unit provides heading data and lamp voltage to the steering repeaters and a MK 37 Mod E relay transmitter. The switch unit drives the step repeaters from heading data.

a. MK 37 Mod E Relay Transmitter The relay transmitter receives heading data and lamp voltage from the switch unit, amplifies the data, and transmits the data and lamp voltage to bearing repeaters, and to other equipment. Each output on the relay transmitter is controlled by a toggle switch.

b. Compass Repeaters The compass repeaters, steering and bearing, provide remote ship's heading as determined by the gyro compass. A dc step motor responds to data signals transmitted from the gyro compass switch unit and relay transmitter. The dc step motor is geared to a compass card which is driven to a point corresponding with the gyro compass heading. The repeaters contain synchronization knobs for aligning the repeater card with the gyro compass. Steering repeaters are mounted on bulkhead mounting brackets which contain a rheostat for varying repeater lamp current and a toggle switch for controlling power to the repeater. Bearing repeaters are mounted on column bearing pelorus stands that contain a rheostat for varying lamp current. Power to the bearing repeaters is controlled by toggle switches in the relay transmitter. Toggle switches in the relay transmitter also control data information to other equipment.

c. Power. The ac power is applied to the gyro control and power assembly through the power converter. The power converter also converts ac to dc and applies dc to the power transfer unit. Upon loss of ship's service power, the power transfer unit applies ship's emergency switchboard battery power to the gyro control and power assembly.

**1-13. Control and Monitoring System** The control and monitoring system provides for the centralization of control and monitoring functions for the main propulsion power train, selected pumps, ship's service diesel generators, and vital alarms. Pilothouse and engine room propulsion control is possible without intervention of engine room personnel. Primary control is from the pilothouse console with one soldier at the engine room console. The system permits constant automatic

monitoring of vital machinery operating conditions and initiation of many functions from the engine room console. The control and monitoring system consists of the following: engine room console, pilothouse console, machinery plant monitoring and alarm system, engine order telegraph, steering control panel, dual station throttle control system, bowthruster and auxiliary fire pump control, fire detection, and bow ramp control.

a. Engine Room Console (ERC). The ERC provides a centralized engine room location for: controlling propulsion shafts direction and speed; monitoring machinery alarm conditions; acknowledging engine orders; alerting engineering personnel of assistance needed and acknowledging the dead man alarm notification from the bridge. These functions are provided to the ERC via interfaces with the machinery plant monitoring system, engine order telegraph, and dual station throttle control system.

b. Pilothouse Console (PHC). The PHC provides control and monitoring of the main propulsion power train speed and direction during usual ship operating and maneuvering conditions without intervention of engine room personnel. The PHC also provides for: machinery plant monitoring; autopilot operation; steering system selection and monitoring; bowthruster/auxiliary fire pump engine control; bowthruster control; communicating desired propulsion shaft direction and speed to the ERC; operation of blinker lights; operation of bow ramp; operation of ship's intercommunications system; and activation of ship's general alarm system. These functions are provided to the PHC via interface with the machinery plant monitoring system; autopilot; steering control panel, helm (wheel) and rudder angle indicator; dual station throttle control system, port and starboard main propulsion engine shaft tachometers; bowthruster engine shaft tachometer; bowthruster control panel; engine order telegraph; blinker light key; ship's intercommunications panel; and the general alarm contactor.

c. Dual Station Throttle Control The dual station throttle control system provides pneumatic direction and throttle control for the main propulsion engines from the PHC and ERC, and the bowthruster/auxiliary fire pump engine from the PHC only.

(1) Main propulsion engine control The system provides two throttle and direction control valves at both the PHC and the ERC. The ERC contains a pilot air valve for ERC control of the system or transfer of control air to the PHC. The PHC contains a pushbutton air valve for control air at the pilothouse.

(2) Bowthruster/auxiliary fire pump engine control The PHC contains a throttle control air valve for bowthruster/auxiliary fire pump selection. Selection results in engaging the appropriate power take-off (PTO). The valve also provides throttle control for the engine.

d. Machinery Plant Monitoring System The machinery plant monitoring system is a microcomputer based system which monitors vital machinery operating conditions. The system consists of the engine room console panel and a color video cathode ray tube (CRT) display on the engine room console and the bridge console panel and color video CRT display located on the pilot house console. The CRT displays date and time, alarm messages, and monitored status. The monitored status is presented in seven pages of displays.

(a) Page 1 - Machinery Plant Control System. Provides a table of contents for the system.

(b) Page 2 - Engine Summary. Displays oil pressure, water temperature, stack temperature, and RPM for both port and starboard main engines.

(c) Page 3 - Engine Summary. Provides oil temperature and oil differential for both port and starboard main engines and also displays left and right main engine bank temperatures for both main engines.

(d) Page 4 - Generator Summary. Displays oil pressure, water temperature, oil temperature, and stack temperature for the port and starboard SSDG engines.

(e) Page 5 - Reduction Gears. Provides oil pressure and oil temperature for the port and starboard reduction gears.

(f) Page 6 - Bowthruster Engine. Displays oil pressure and water temperature for the bowthruster engine.

(g) Page 7 - Fire Pump/Main. Provides valves for main and emergency system, control air pressure, and start air pressure for the port and starboard main engines and SSDG number 2.

(1) Engine room console panel. The engine room console panel provides a centralized engine room location for starting and stopping the bilge/ballast pump, fresh water makers, fresh water pumps, fire pumps, ship's service diesel generators, and main propulsion engines. Indicator lamps are provided for run condition display of other equipment, control station in operation (PHC or ERC), dead man alarm, and engineers'-assistance-needed pushbuttons. The panel also provides controls for the CRT display and audible alarm.

(2) Bridge console panel. The bridge console panel provides controls for main propulsion engines emergency stop, bowthruster/auxiliary fire pump engine start and stop, exhaust and supply ventilator fans shutdown, fire pumps No. 1 and No. 2 start and stop, and dead man alarm illuminated pushbutton. Indicator lamps are provided for port and starboard steering motor running, control station in operation, bowthruster engine running, and fire pumps No. 1 or No. 2 running. The panel also provides controls for operating the panel and CRT display.

e. Engine Order Telegraph (EOT). The EOT communicates desired propeller shaft speed and direction from the pilothouse console to the engine room console when the bridge is not in direct control of the main engines. The system consists of drop-in panels in both the ERC and PHC. The panels contain illuminated pushbuttons and bells. The bells ring at both locations. A two-wire data connection between the panels is used to send and acknowledge orders taken or sent from either panel. Direction is monitored in ahead, astern, and stop position. Wrong direction status is visually and audibly alarmed at both stations. Each panel also alarms for order and power failures.

(1) Power group The power group consists of two illuminated pushbuttons: PWR ON/LAMP TEST and COMM FAIL/SILENCE. The PWR ON/LAMP TEST pushbutton will apply power to that unit:- a power failure of one of the two independent power supplies, fed from Wheel House DC Panel EP024-1, causes the PWR ON/LAMP TEST to flash on and off and the audible alarm to sound. Pushing the pushbutton will silence the alarm, and if one of the power supplies has failed, the PWR ON/LAMP TEST will continue to flash. If both power supplies are available, the lamp will light steady. When a unit is first turned on, or power is restored, the PWR ON/LAMP TEST lamp will flash and the audible alarms will activate. Pushing the pushbutton will silence the alarms and cause the lamp to light steady. The unit then will update itself to the other unit and display any detected faults by alarm or flashing lamps. Communication failure-between EOT units will be alarmed by the flashing COMM FAIL/SILENCE illuminated pushbutton and audible alarms. Pushing the pushbutton will silence the audible alarm, and the front panel will display various types of communication failures by indicator lamps. Silencing an alarm within a unit group silences all alarms in that group.

(2) Port and starboard telegraph groupThis group consists of ten port and starboard commands (orders): four ahead (AHD) orders, four astern (AST) orders, one BRIDGE CONTROL order, and one STOP order. Completed orders are displayed as steadily illuminated pushbuttons and silenced audible alarms. A new order can be placed by pushing another pushbutton which then flashes at both stations (pilothouse and engine room consoles). At the same time, the internal horn sounds, and will continue to sound until the new order is acknowledged. The new order is acknowledged at the receiver station by pushing the flashing pushbutton, which then turns to the steady mode. The previous order is then canceled, and all audible alarms are silenced. New orders can be changed or canceled at the sending unit prior to acknowledgment by pushing another order pushbutton. When the BRIDGE CONTROL order is acknowledged, the AHD, STOP, and AST pushbutton lamps are turned off. When bridge control is relinquished by placing and acknowledging another order, the BRIDGE CONTROL lamp is turned off, thereby indicating engine room control.

(3) Wrong direction group This group consists of two indicating lamps (port and starboard shafts) which alarm when a wrong direction condition exists. The wrong direction display and alarm is active after an AHD, STOP, or AST order is acknowledged. If the order has been acknowledged and the shaft direction does not match the order (AHD-STOP-AST), the wrong direction alarm is activated (WRONG DIRECTION lamp flashes and audible alarm sounds). The flashing WRONG DIRECTION alarm lamp operates immediately but the audible alarm may be delayed to compensate for changing of direction from AHD to AST or AST to AHD. When the correct direction status is achieved, the wrong direction visual and audible alarms are canceled. If the direction of propulsion thrust changes from the acknowledged EOT direction, then the wrong direction alarm is re-activated.

(4) Standby/finished with engines groupThis group consists of three illuminated pushbuttons: STANDBY, CANCEL STANDBY, and FINISHED WITH ENGINES. Together, they function as a separate EOT group similar to the port and starboard EOT groups.

(a) A STANDBY order may be placed independently of any other order.

(b) STANDBY, whether acknowledged or not, may be canceled by a CANCEL STANDBY order from the initiating EOT.



(c) A receiving EOT must acknowledge a STANDBY order before it can issue a CANCEL STANDBY order.

(d) If the port and/or starboard EOT are active, a FINISHED WITH ENGINES order may be initiated only if both port and starboard EOTs have acknowledged BRIDGE CONTROL or STOP orders.

f. Steering Control Panel The steering control panel is located on the pilothouse console. The panel provides system power selection, mode of operation including full followup (FFU) using the helm, non-followup (NFU) using pushbutton switches on the panel, and AUTO (autopilot). The panel also contains an alarm panel for each steering gear pumpset, alarm test switch, and cancel switch to silence the alarm. Rudder position commands are input to the steering gear by movement of the helm or pressing pushbutton switches. These input signals operate solenoid activated hydraulic control valves in the pumpset selected. The control valves direct the flow of hydraulic fluid from the pumpset to power cylinders attached to the rudder tiller arms which position the rudder. The steering control panel contains a rudder angle indicator that displays the actual rudder position in degrees. A rudder order indicator below the panel displays a direct indication of the actual position of the helm. The pumpset status panel includes two sets of six indicators which give information on the status of each pumpset system. The green status lamps (POWER AVAILABLE, MOTOR RUN) intensity is adjustable by a DIMMER control. The remainder of the status lamps are activated by alarm sensors and remain on after the alarm horn has been canceled, and until the fault is cleared. The NFU pushbutton switches operate relays, which in turn operate the pumpset solenoids until released. The rudder will then remain stationary to the position commanded. When in FFU or AUTO mode, the NFU pushbuttons control the rudder to move in the direction commanded as long as the pushbuttons are depressed. Upon releasing a NFU pushbutton, steering control of the rudder will return to the control mode selected: When in FFU, steering responds to the action of the helm. The rudder will continue to move after the helm is moved to the desired position, until the rudder matches the exact position of the helm as indicated by the rudder order indicator. When in AUTO mode, the course set by the AUTOPILOT allows hands-off steering of the vessel.

g. Bowthruster Control The bowthruster control panel located on the pilothouse console provides control and monitoring of the bowthruster water jet operation. Indicator lamps are provided to indicate that electrical power and hydraulic power are available, minimum hydraulic oil level in the hydraulic oil tank, and minimum lube oil level in the lube oil tank. Alarm horns accompany the visual indication of minimum hydraulic oil and lube oil tank levels. Pushbutton controls are also provided for activating the electrical power unit and hydraulic unit. A toggle switch is used for steering the water jet nozzle to the angle of thrust desired. The angle of thrust is displayed on a meter.

h. Fire Detection The fire control panel is located in the aft section of the pilothouse and provides the bridge with status of the vessel fire detection system. The fire control panel is the system main controller processor. It processes all incoming signals from each vessel zone and converts them to an independent output that is displayed on the panel: alarm horn, alarm and status lamps, trouble lamps, battery charger, current and voltage meters. Controls are provided for system reset and lamp testing, alarm silencing, and trouble silencing.

i. Bow Ramp Control. The bow ramp control system consists of three bow ramp control panels: pilothouse console, boatswain storeroom (bow ramp winch), and starboard forecastle deck. Controls are provided for turning the winch electric motor off and on (PHC and boatswain storeroom only) and raising and lowering the ramp. Pushbuttons are provided for starting and stopping the winch hydraulic pump and taking up tension (slack) on the wire rope. Indicator lamps provide visual display of hydraulic oil temperature, (above 150°F), tension (slack wire rope), and hydraulic pump running.

j. Dead Man Alarm. The dead man alarm system is incorporated in the machinery plant monitoring engine room console panel and bridge console panel. The bridge console panel contains an illuminated pushbutton that when depressed causes the corresponding illuminated pushbutton and audible horn on the engine room console panel to be activated. If the engine room attendant does not acknowledge the dead man activation by the bridge within a specified time, alarms will sound, signifying the engine room attendant cannot acknowledge. If the engine room attendant answers the dead man alarm within the specified time, both illuminated pushbuttons will extinguish and horn will be silenced.

k. Engineer's Assistance Needed The engineer's assistance needed system is incorporated in the machinery plant monitoring engine room console panel. The assistance needed system notifies off watch engineers that the ERC attendant needs assistance. The system is activated when the ENGINEER ASSISTANCE NEEDED illuminated pushbutton on the ERC is pushed. This action causes an audible alarm and flashing lamp to be activated at remote panels in the mess room and the chief engineer's stateroom. Pressing the illuminated pushbutton on one of the remote panels will acknowledge the assistance needed request. The system will also be activated by the dead man alarm system if the ERC attendant does not acknowledge the dead man alarm in the specified time limit.

**1-14. Fire Detection System.** The fire detection system (FIGURE 1-33) sounds an alarm when fire is detected via temperature rate-of-heat rise detectors located throughout the LCU. The system consists of the fire control panel located in the pilothouse, a terminal box, heat rise detectors (thermostats) located in various compartments, manual pull stations, and a 10-inch bell. The heat detectors are arranged in six zones throughout the vessel. When a fire condition is detected, the associated thermostat sends an alarm signal, via a zone module located in the fire control panel to the fire control panel indicators. When pulled, the manual fire pull box also sends an alarm signal via the zone module to the marine fire detector panel indicators.

**1-15. Steering Gear System.** The steering gear system is an electrically driven, hydraulically operated system (FIGURE 1-34) that positions the rudders in response to steering commands. Rudder position commands are input to the steering gear by the movement of the ship's helm (wheel) to generate an electrical signal. The signal operates solenoid activated hydraulic control valves in the hydraulic power unit. The control valves direct the flow of hydraulic fluid from the hydraulic pump to power cylinders attached to the rudder tiller arms which position the rudder. The hydraulic system consists of redundant electrical-hydraulic power units. Either unit can be selected from the pilothouse console steering control panel. If electric power is lost, a hand pump provides a backup steering system. The hand pump is a manually operated, reversible, positive displacement rotary pump used for emergency steering.

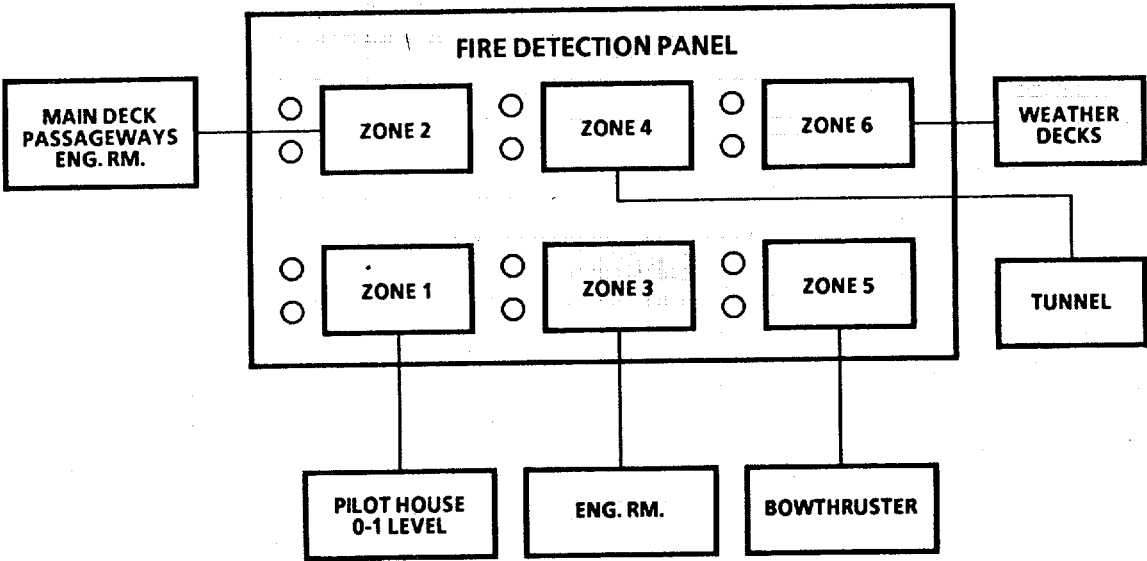
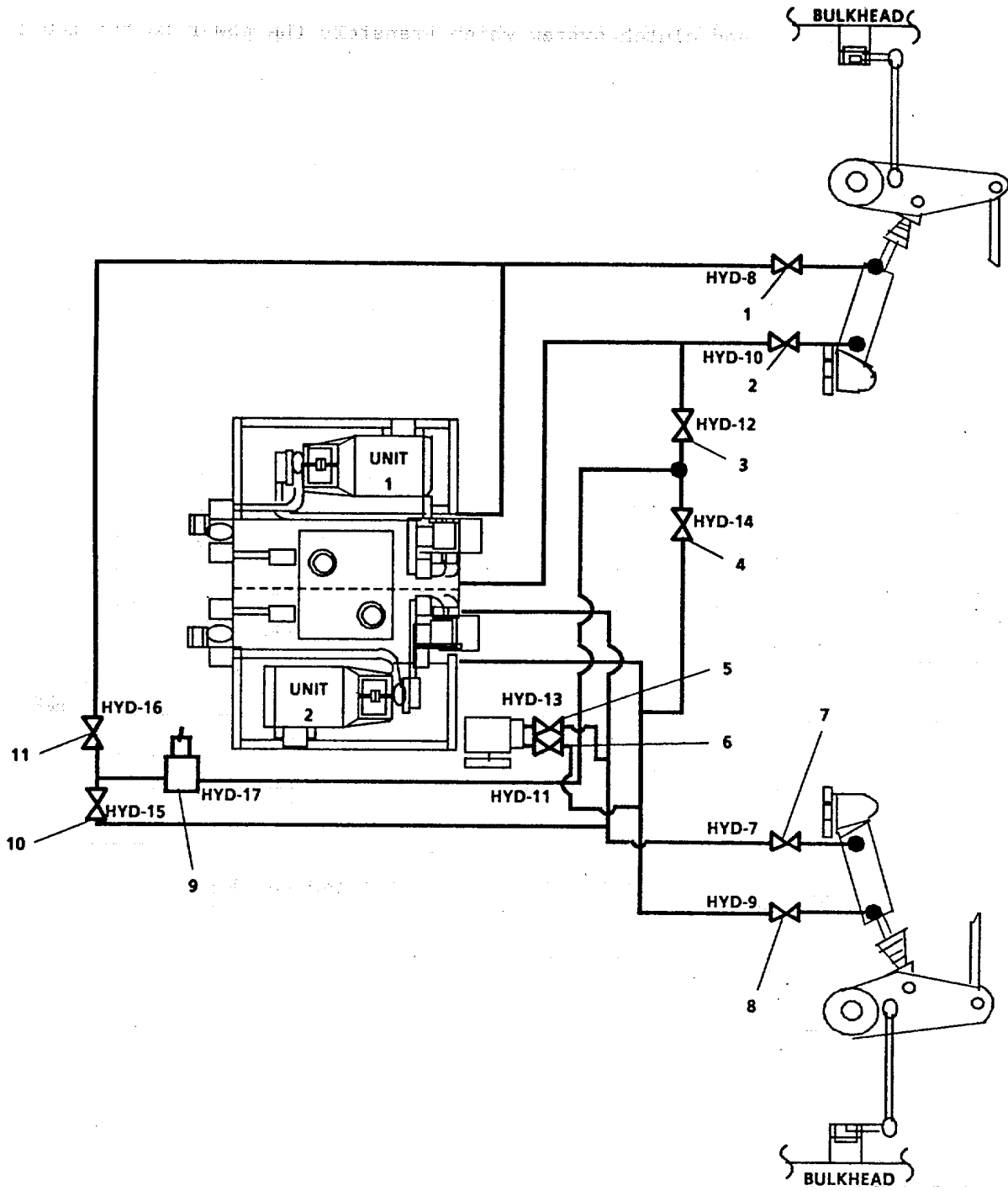

FIGURE 1-33. Fire Detection System.



**LEGEND**

- |                                   |                                  |
|-----------------------------------|----------------------------------|
| 1. HYD-8, LOCK VLV-STBD PORT RAM  | 6. HYD-11, HAND PUMP ILSN        |
| 2. HYD-10, LOCK VLV-PORT STRG RAM | 7. HYD-7, LOCK VLV-STBD STRG RAM |
| 3. HYD-12, UNIT NO. 1 ISLN        | 8. HYD-9, LOCK VLV STBD STRG RAM |
| 4. HYD-14, UNIT NO. 2 ISLN        | 9. HYD-17, RELIEF VALVE          |
| 5. HYD-13, HAND PUMP ILSN         | 10. HYD-15, UNIT NO. 2 ISLN      |
|                                   | 11. HYD-16, UNIT NO. 1 ISLN      |

FIGURE 1-34. Steering Gear Hydraulic Piping System.

**1-16. Main Propulsion System.** The main propulsion system is the power source for the main reduction gear and clutch system which transfers the power to the LCU's propellers. The system consists of two diesel engines. The engines counter-rotate; the port engine rotates counterclockwise, and the starboard engine rotates clockwise. The engines can be operated together or individually.

a. Engine Instrument and Control Panel. The engine control panel contains indicators which monitor the operation of the engine. Conditions monitored by the control panel are oil temperature, oil pressure, cooling water temperature, oil differential pressure across oil filters, exhaust temperature by bank, starting air pressure, engine RPM (tachometer), and total engine operating hours. These conditions are monitored at the engine room console (ERC) and pilothouse console by the machinery plant monitoring system. The engines can be started and stopped locally at the panel and remotely from the ERC. The engine may be stopped from the PHC, utilizing the main engine emergency trip pushbuttons.

b. Fuel System. The fuel system which is composed of a fuel pump containing a governor, is driven by the front engine gear train. Filtered fuel is supplied to the injectors via the fuel manifold and cylinder head drillings. Timing is provided by a camshaft through cam rollers and push-tubes to injector rockers which actuate the injectors at the proper time. The governor maintains the speed of the engine at a setting determined by the engine operator. An automatic shutdown feature, which is controlled from the machinery plant monitoring system, will energize a shutdown solenoid, cutting off fuel flow to the engine. This solenoid also contains a plunger for manual shutdown. The fuel system receives fuel oil from the fuel oil transfer piping system.

c. Air Starting System. The main engine air starting system provides low pressure air to starting motors during engine startup. When energized, a solenoid valve releases air to the starting motor and the motor cranks the engine. The air starting system requires low pressure air from the compressed air piping system.

d. Lubricating Oil System. The engine is pressure lubricated by a gear-type oil pump mounted to the block and driven by the rear crankshaft gear. The lubricating oil system receives oil from and returns oil to the engine sump. Lubricating oil is supplied to the engine sump from the external lubricating oil tank via the lube oil transfer and dirty oil discharge piping system.

e. Cooling System. The main engine cooling system provides fresh water cooling to the engines. The cooling system receives fresh water from the fresh water cooling piping system. Fresh water is drawn into the cooling system by centrifugal pumps, pumped through the engine and discharged back to the fresh water cooling piping system. The piping system then routes the heated water through the keel cooler to cool the fresh water before it is pumped back through the engines. The cooling system also contains expansion tanks that handle cooling system overflow and provide a convenient point for adding coolant to the system.

**1-17. Reverse Reduction Gearbox System.** The reverse reduction gearbox provides power (torque) transfer from the main engines to the propeller shafts. The system consists of the reverse reduction gear and lubricating oil cooling pump.

a. Reverse Reduction Gear. The reverse reduction gear reduces the engine output revolutions per minute (RPM) and reverses rotational direction to the propeller shaft. Direction of rotation and clutch operation are controlled by each engine's throttle control on the ERC or PHC. Power is transmitted by disk clutches and pinion gears.

b. Lubricating Oil Cooling Pump. The reverse reduction gear lubricating oil cooling pump cools the reduction gear cooling oil via water drawn from the keel cooler. The pump is activated by a switch on the engine control panel.

c. Shaft Brake. Locks the shaft when the propulsion system is in neutral to prevent the shaft from turning.

**1-18. Bowthruster Power System** The bowthruster power system powers the bowthruster waterjet and the auxiliary fire pump. The system consists of a diesel engine with a power takeoff (reduction gear) on each end.

a. Engine Instrument Control Panel. The engine control panel contains indicators which monitor the operational condition of the engine, power takeoff, and battery voltage. Conditions monitored by the control panel are: engine oil pressure, engine RPM, engine cooling water temperature, gear (power takeoff) oil pressure, battery voltage, and engine exhaust temperature by bank. Engine oil pressure, engine jacket water temperature, and an engine running indicator are also monitored by the machinery plant monitoring system on the PHC panel. The engine may be started at either the control panel or the PHC.

b. Electrical System. Electrical power to the engine is 24 Vdc from the external batteries located in the bowthruster compartment, supplying power to instrument and control panel, starter motor, and solenoid.

c. Fuel System. The fuel system is a pressure time (PT) type consisting of the fuel pump, supply lines, drain lines, fuel passages, and injectors. The fuel pump, containing a governor, is driven by the front engine gear train. Filtered fuel is supplied to the injectors via the fuel manifold and cylinder head drillings. Timing is provided by a camshaft through can rollers and push-tubes to injector rockers which actuate the injectors at the proper time. The governor maintains the speed of the engine at a setting determined by the engine operator. An automatic shutdown feature, which is controlled from the machinery plant monitoring system, will energize a shutdown solenoid, cutting off fuel flow to the engine. This solenoid also contains a plunger for manual shutdown. The fuel system receives fuel oil from the fuel oil transfer piping system.

d. Lubrication System. The lubrication system provides lubricating oil under pressure by a gear-driven type oil pump mounted to the block and driven by the front gear train. The engine receives lubricating oil from and returns oil to the engine sump. Lubricating oil is supplied to the engine sump from the external lubricating oil tank via the lube oil transfer and dirty oil discharge piping system.

e. Cooling System. The cooling system removes heat created by the engine and its support components. Cooling water is circulated by a belt-driven centrifugal water pump through the engine block and cylinder heads and the heat exchanger, with a portion going through the lubricating oil cooler. Seawater is piped through the heat exchanger to cool the cooling water. The cooling system receives fresh water from the fresh water cooling piping system.

f. Power Takeoff. The engine transfers power to the bowthruster waterjet and auxiliary fire pump through twin-disk marine drive reduction gears. Each marine drive clutch is pneumatically operated via a control located on the PHC. Each marine drive utilizes self-contained lubrication.

**1-19. Bowthruster Waterjet System.** The bowthruster waterjet system is a propulsion and steering system located at the bow and used in combination with the ship's main propulsion system to give the LCU added maneuverability. A high volume jet pump driven by the bowthruster/auxiliary fire pump diesel engine is the propulsion element. Throttling the engine increases or decreases the thrust force. Twin hydraulic steering motors point the jet nozzle to any desired relative bearing, controlling thrust angle. Displacement of seawater in a given direction generates an equal recoil force in the opposite direction, moving the bow of the LCU as needed. Control of the bowthruster waterjet is from the PHC by the bowthruster control panel. The bowthruster control panel provides controls for starting and stopping the electric and hydraulic units, steering the nozzle, and silencing the alarm horn. The panel also contains indicator lamps for electric and hydraulic units running, minimum hydraulic oil tank and minimum lubricating oil tank levels, and a thrust direction indicator.

**1-20. Bow Anchor Windlass System.** The bow anchor windlass system is a hydraulic driven chain windlass for handling the LCU's bow anchors and stud link anchor chain. The system consists of two port and two starboard bow anchor windlass assemblies, hydraulic power pack assemblies, and directional control valves. The windlass is controlled from a bow control box located adjacent to each windlass on the forecastle deck. The bow control box contains controls for starting and stopping the hydraulic power pack and hauling in or paying out the windlass. Each windlass has a single wildcat for anchor chain handling and gypsy catheads on each-end for rope handling. The hydraulic power pack provides hydraulic pressure for the directional control valve which controls the direction of the wildcat, which in turn hauls in or pays out anchor chain. Auxiliary clutches transfer power to the outboard and inboard gypsies. The unit contains a spring loaded failsafe brake system; hydraulic pressure is required to release and to hold off the brake. Any function which reduces hydraulic pressure below the release pressure of the brake will cause brake application. A hand brake is provided for manually braking the windlass. The electro-hydraulic power unit for the port windlass is located in the forward area of the bowthruster room, and the starboard windlass power unit is located in the forward inboard side of the boatswain storeroom.

**1-21. Bow Ramp System.** The bow ramp system provides a means of lowering and raising the bow ramp. The system consists of a hydraulic power pack, a winch assembly, and ramp lifting assemblies.

a. Hydraulic Power Pack. The hydraulic power pack provides power to the winch assembly. The power pack consists of an electric motor, drive coupling, hydraulic pump and fluid reservoir tank, and associated pipes, valves, and gauges. The hydraulic power pack is located in the boatswain's storeroom.

b. Winch Assembly. The winch assembly takes in or pays out wire rope for raising or lowering the bow ramp. The assembly consists of a hydraulic motor, hydraulic failsafe brake, drum, slack wire limit switch, and emergency hand crank. The winch assembly is located in the boatswain's storeroom adjacent to the hydraulic power pack.

c. Ramp Lifting Assemblies. The ramp lifting assemblies provide wire rope deck access from the winch assembly to the bow ramp chain. These assemblies are wire rope, turnbuckles, stud chain, rope sheave, chain stopper, wildcat sheave, ramplocking device and wire rope glands port and starboard. The bow ramp is raised and lowered by the split-drum, hydraulic winch via wire rope. The drum handles two wire ropes, one to control each side of the ramp. Wire rope is fed to the forecastle deck through wire rope glands and rigged to chains by turnbuckles. The chain is led through chain stoppers to a chain sheave. The winch is remotely controlled from three locations: pilothouse console, forecastle deck and at the winch assembly. The pilothouse console control panel has a power on/off switch. When operating from the pilothouse console, the other two control stations are inoperative.

**1-22. Stem Anchor Winch System.** The stern anchor winch system provides payout and haulback of the stern anchor. The first wrap speed of the winch is 35 feet per minute at high speed and 17 feet per minute at low speed. The system consists of a winch assembly, hydraulic power pack, Danforth anchor, anchor chain assembly and deck equipment. Control of the stern anchor winch is provided by a control panel on the 01 level aft bulkhead, adjacent to the winch.

a. Winch Assembly. The winch assembly is mounted to its foundation on the aft 01 level center line of the ship. The winch spool is mounted directly on the shaft and is free to rotate on the shaft. Drive is applied by means of a manually operated, four-jaw, sliding clutch. The clutch lever can be locked in either the engaged or disengaged position. The mechanical brake is manually operated by a handwheel. A lever operated dog, which engages the spool, mechanically locks the winch when not in operation. A level wind provides smooth laying of the wire rope on the spool.

b. Hydraulic Power Pack. The hydraulic power pack assembly consists of a hydraulic pump driven by an electric motor mounted on the hydraulic fluid reservoir located in steering gear room. The pump feeds a directional control valve that controls payout, haulback and neutral operation of the winch assembly.

c. Hydraulic Motor/Failsafe Brake Assembly. Hydraulic fluid, under pressure from the power pack, powers the hydraulic motor. The motor is coupled to the gear box on the winch via an automatic failsafe brake. The brake is spring loaded for application and hydraulic pressure is required for release. Any function which reduces hydraulic pressure below the release pressure of the failsafe brake will cause brake application.

**1-23. Commissary Equipment.** Commissary equipment provides for chilled and frozen food storage, food preparation, food service, waste disposal, sanitation and galley exhaust and fire protection. Chilled and frozen food storage units are freestanding refrigeration units. Food preparation units are freestanding steam kettle, ranges, microwave ovens, fryers and associated equipment. Food service units include milk dispenser, coffee maker and soft drink dispensing machine. Waste disposal and sanitation are provided by a garbage disposal, solid waste compactor and dishwasher. The dishwasher and garbage disposal are connected to the ship's sewage piping system. Galley air exhaust is provided by an exhaust hood tied to ducting and galley exhaust fan which is part of the environmental control system.



**1-24. Laundry Equipment.** Laundry equipment is used by the LCU crew to wash, dry and maintain uniforms and linen. Laundry equipment consists of an electric automatic washer, electric dryer, ironing board, clothes wringer, double sink and storage cabinet. The automatic washer and double sink drain to the ship's sewage piping system.

**1-25. Fire Fighting System.** The fire fighting system provides fire stations and specialized chemical fire suppression equipment throughout the vessel. The fire fighting system consists of HALON fire suppression systems, foam proportioners, foam tank, fire stations, fire monitors, fire fighting equipment and washdown system.

**NOTE**

**Not applicable to vessels with FM-200 Fire Suppressant System installed. Reference paragraph 2-46 through 2-47 for FM-200 and Water Washdown System operation. Reference TM 55-1905-243-24&P, LCU-2000, FM-200 Fire Fighting System for maintenance and installation of FM-200 components.**

a. HALON 1301 Fire Suppression System. The HALON system provides fire suppression where highly flammable conditions exist. These areas are the main engine room and paint locker room. The system extinguishes fires in these spaces by totally flooding the space with HALON 1301 agent. The system may be manually actuated by pull cables or pneumatic actuators. Rate of rise temperature detectors, when activated, set off an alarm in the pilothouse; however, the detectors do NOT automatically start the HALON system. There is a 60 second delay during which the siren sounds, warning personnel to evacuate the protected area. Pressure switches interconnected with the electrical system of the LCU are activated during the delay for ventilation equipment and lube/fuel oil pump shutdown. Upon discharge, the HALON cylinders will release and flood the designated area in approximately 10 seconds.

b. Foam Proportioners. The fire fighting system has the capability of inducing aqueous film forming foam (AFFF) into the fire monitors and foam stations. Liquid AFFF is induced into the system via two AFFF three-way proportioners that provide suction to the AFFF tank when water pressure is supplied from either fire pump No. 1 or 2, auxiliary fire pump or bilge/ballast pump through system alignment. The system has the capability to discharge sufficient foam to cover the main deck through fire monitors port and starboard (pilot house top), foam station 2 (pilot house top) and foam station 1 (engine room) with 6 inches of foam. This foam proportioning system can be aligned to supply seawater only, by closing the two AFFF tank suction valves.

c. Fire Stations. Fire stations provide seawater for fire suppression throughout the ship. Fire stations consists of fire plugs connected to the bilge/ballast and fire main piping system. Installed at each fire station is an all-purpose nozzle with 50 ft. of hose and a spanner wrench.

d. Fire Monitors. Two fire monitor stations are located on the pilot house top. The monitors provide 360-degree coverage of the main deck. Each monitor has both horizontal and vertical control. These monitors can be aligned to disperse seawater or foam. Piping for the fire monitor supply is routed out of the machinery space via risers to the 02 level (FIGURE 1-35) pilot house top (port and starboard).

e. Dry Chemical Extinguishers. Dry chemical extinguishers provide fire suppression for chemical and liquids that are difficult to extinguish. Each disperses a powder that interrupts the chemical reaction of the fire. The chemicals suspend fine particles in the fire to screen the fire from oxygen and fuel sources, thereby extinguishing the fire.

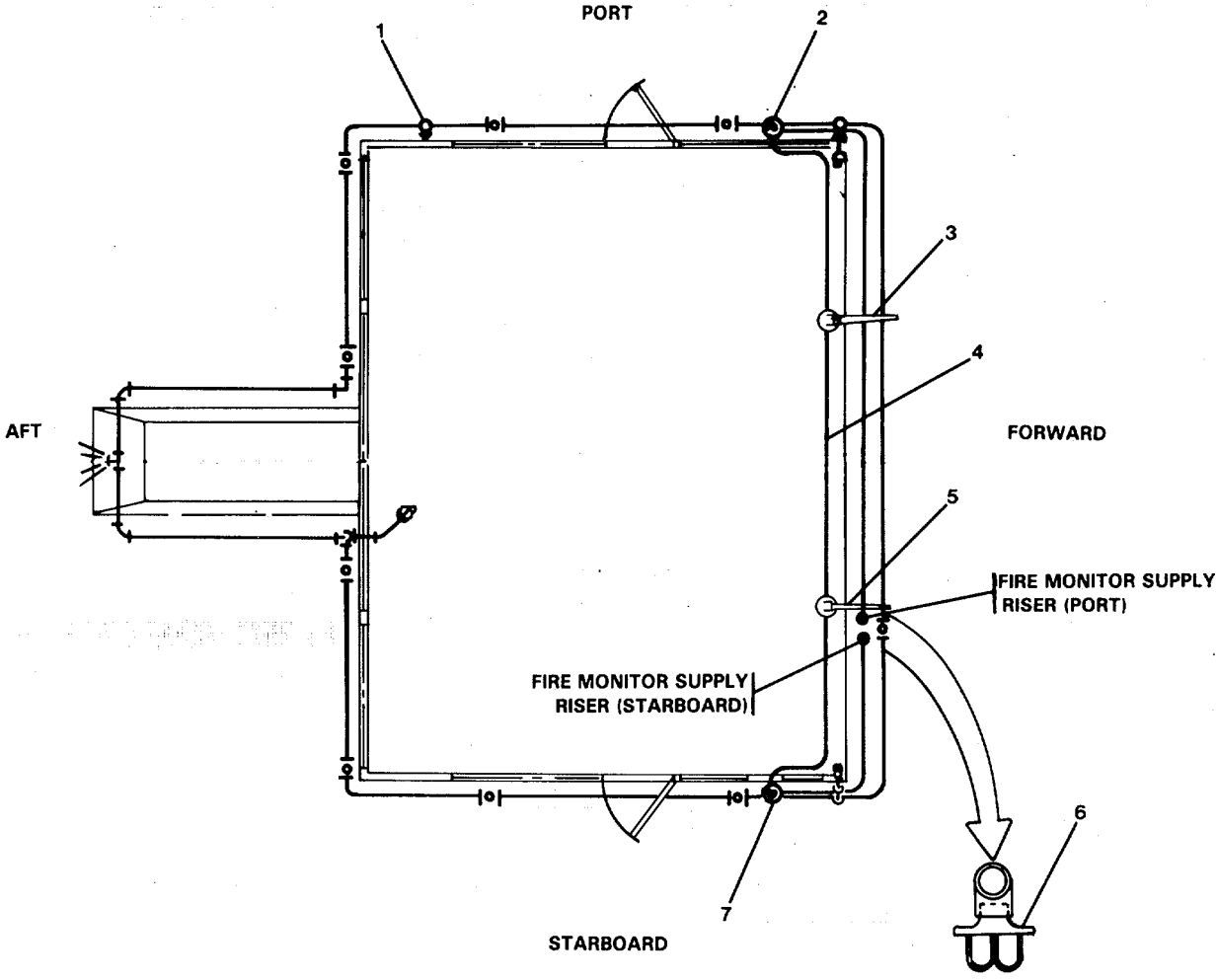

02 LEVEL  
(PILOTHOUSE TOP)

LEGEND

- |                                   |                                   |
|-----------------------------------|-----------------------------------|
| 1. COUNTERMEASURE WASHDOWN SUPPLY | 5. FIRE MONITOR (STARBOARD)       |
| 2. FIRE MONITOR SUPPLY FROM RISER | 6. SPRAY HEAD                     |
| 3. FIRE MONITOR (PORT)            | 7. FIRE MONITOR SUPPLY FROM RISER |
| 4. FIRE MONITOR SUPPLY LINE       |                                   |

FIGURE 1-35. Fire Monitor and Countermeasure Washdown Piping System - 02 Level.

f. Oxygen Breathing Apparatus (OBA). The oxygen breathing apparatus provides oxygen to the wearer for entering smoke filled compartments to fight fires. When activated, a chlorate candle within the apparatus generates oxygen and supplies it to the breathing bag. Chemicals within the canister remove moisture and carbon dioxide from the exhaled air and return the remainder of the air to the breathing bag. A pressure relief valve vents excess pressure from the breathing bag.

g. Countermeasure Washdown. The countermeasure washdown system (FIGURE 1-36) provides an umbrella of seawater over the superstructure to counter nuclear, biological, and chemical (NBC) attack. Seawater from the fire main is directed through washdown piping serving spray heads to wash down the superstructure. Spray heads and piping are located around the main deck (FIGURE 1-37), 01 (FIGURE 1-38) and 02 (FIGURE 1-35) levels. The system is activated by a valve in the engine room. Seawater for the system is routed out of the machinery space via a riser to the 01 level and a riser from the 01 level to the 02 level. Piping surrounding each level contains spray heads that disperse seawater. The system is activated from the fire main fire monitor and countermeasure washdown gate valve, located in the machinery space.

**1-26. Autopilot.** The autopilot is an automatic steering control system that uses heading information from the ship's gyrocompass to control the ship's steering gear. The autopilot energizes directional control valve solenoids, part of the ship's steering gear, in order to maintain selected heading. The autopilot heading selector combines the functions of a heading selector with a gyrocompass repeater. The heading selector contains controls that permit the selection of operating mode and desired heading. The autopilot control amplifier processes signals from the autopilot heading selector and the rudder repeatback unit to develop steering signals that are sent to the steering gear solenoids. This provides rudder control. The autopilot rudder repeatback unit sends signals from the steering gear, providing rudder position information, back to the autopilot control amplifier.

**1-27. Magnetic Compass.** The magnetic compass provides heading information to the pilothouse using a reflector compass mounted in a periscope binnacle. The binnacle is mounted on the pilothouse top with the periscope assembly extending down through the pilothouse top deck into the pilothouse just forward of the helm. A reflection of the compass card is projected through a series of lenses in the binnacle down to an adjustable mirror in the periscope assembly. The compass can be read directly at the binnacle through a viewing window or in the pilothouse via the mirror. A toggle switch and dimmer rheostat, located on the binnacle, control power to a lamp located in the binnacle hood.

**1-28. Navigation Lighting System.** The navigation lighting system provides the appropriate exterior lights for safe navigation. The system is controlled from the navigation lighting panel located in the aft area of the pilothouse.

**1-29. Sound Powered Telephone System** The sound powered telephone system provides voice communications throughout the ship. The system contains fixed phone stations and portable units. Since the system is powered by voice only, it is functional even with the loss of all ship's power. There are three circuits, JA, JV1, and JV2 within the sound powered telephone system.

**1-30. FM-200 Fixed Fire Suppression System.** The FM-200 Total Flooding Fire Extinguishing Systems on LCU-2K consists of five (5) manually actuated systems.

- a. Engine Room. This manually actuated system is designed and installed to protect the Engine Room and bilge (3-25-0-E), Frames 25 to 44. The physical location of this system, less FM-200 distribution piping and nozzles, Electric Horn/Strobe and Warning Lights (Amber Strobe), is installed outside of the protected space. Two (2) each 600 pound cylinders and supporting components, installed on the forward bulkhead, Frame 42 ½, A/C and Emergency Generator Room (1-43-0-E), provide protection for the Engine Room and bilge. One (1) each 350 pound cylinder and supporting components, installed on the 7'0" off centerline longitudinal bulkhead, Starboard side, Frames 23 to 24, Tunnel (3-17-0-Q), provide protection for the Forward Engine Room (MCC/Storeroom/Machine shop areas) and bilges.
- b. Tunnel. This manually actuated system is designed and installed to protect the Tunnel and bilge (3-17-0-Q), Frame 17 to 25. The physical location of this system, less FM-200 distribution piping and nozzles, Electric Horn/Strobe, and Warning Light (Amber Strobe), is installed outside of the protected space. One (1) each 350 pound FM-200 cylinder and supporting components, installed on the 7'0" off centerline longitudinal bulkhead, Port side, Frames 19 to 20, Tunnel (3-17-0-Q), provides protection for Bow Thruster Room and bilge.
- c. Bow Thruster Room. This manually actuated system is designed and installed to protect the Bow Thruster Room and bilge (3-5-0-E), Frames 5 to 17. The physical location of this system, less FM-200 distribution piping and nozzles, Electric Horn/Strobe, and Warning Light (Amber Strobe), is installed outside of the protected space. One (1) each 350 pound FM-200 cylinder and supporting components, installed on the 7'0" off centerline longitudinal bulkhead, Port side Frames 19 to 20, Tunnel (3-17-0-Q), provides protection for Bow Thruster Room and bilge.
- d. Paint Locker. This manually actuated system is designed and installed to protect the Paint Locker (1-0-2-Q), Frames 0 to 13. The physical location of this system, less FM-200 distribution piping and nozzle and FM-200 Siren, is installed outside the protected space. One (1) each 125 pound FM-200 cylinder and supporting components, installed on the 7'0" off centerline longitudinal bulkhead, Port side, Frame 10, Bow Thruster Room (3-5-0-E), provide protection for the Paint Locker.
- e. A/C and Emergency Generator Room. This manually activated system is designed and installed to protect the A/C and Emergency Generator Room (1-43-0-E), Frames 42 ½ to 52. The physical location of this system, less FM-200 distribution piping and nozzles, Electric Horn/Strobe, and Warning Light (Amber Strobe), is installed outside of the protected space. One (1) each 125 pound FM-200 cylinder and supporting components, installed in the Stowage Locker (1-43-1-Q), Frames 43 to 44, provides protection for A/C and Emergency Generator Room.
- f. Related Installations. The Engine Room, Tunnel and Bow Thruster Room FM-200 installations are supplemented by the installation of a Water Washdown System (WWS). This manually activated system serves to quickly reduce compartment temperature prior to discharge of FM-200 agent, minimizes production of Hydrogen Fluoride (HF) Gas generated as a result of FM-200 agent decomposition from contact with hot surfaces and flame at temperatures above 1300°F, aids in scrubbing of any HF Gas generated and expedites ventilation of the compartment. Operation instructions for the WWS are contained in paragraph 2-47. For maintenance and installation of the Water Washdown System (WWS) components reference TM 55-1905-243-24&P.

**1-31. Water Washdown System (WWS).** The WWS built of all stainless components are three (3) separate systems installed in the Engine Room, Tunnel and Bow Thruster Room. The WWS is a hydrogen fluoride (HF) gas mitigation, water washdown system (WWS) which provides general overhead coverage to the protected spaces. The WWS is a simple overhead sprinkler grid which is piped directly to the existing firemain. It receives seawater from the Bow Thruster Emergency Fire Pump (Engine Room WWS) and two (2) Engine Room Fire Pumps (Bow Thruster Room and Tunnel WWS). The Bow Thruster Emergency Fire Pump is powered by the Bow Thruster diesel engine and the two (2) Engine Room Fire Pumps are powered electrically from the Ships Service Switchboard 240 V Distribution Panel.

**WARNING**

**The WWS is not designed nor intended to be a stand alone fire extinguishing system. It is designed to be used in conjunction with the installed FM-200 Fixed Fire Suppression System.**

The WWS, upon activation, serves to:

- Quickly reduce the temperature within the protected space.
- Minimize production of Hydrogen Fluoride (HF) Gas which is produced as a result of FM-200 agent decomposition in contact with hot surfaces and flame at temperatures above 1300° F.
- Aid in scrubbing of any HF Gas generated.
- Expedite ventilation of the protected space.

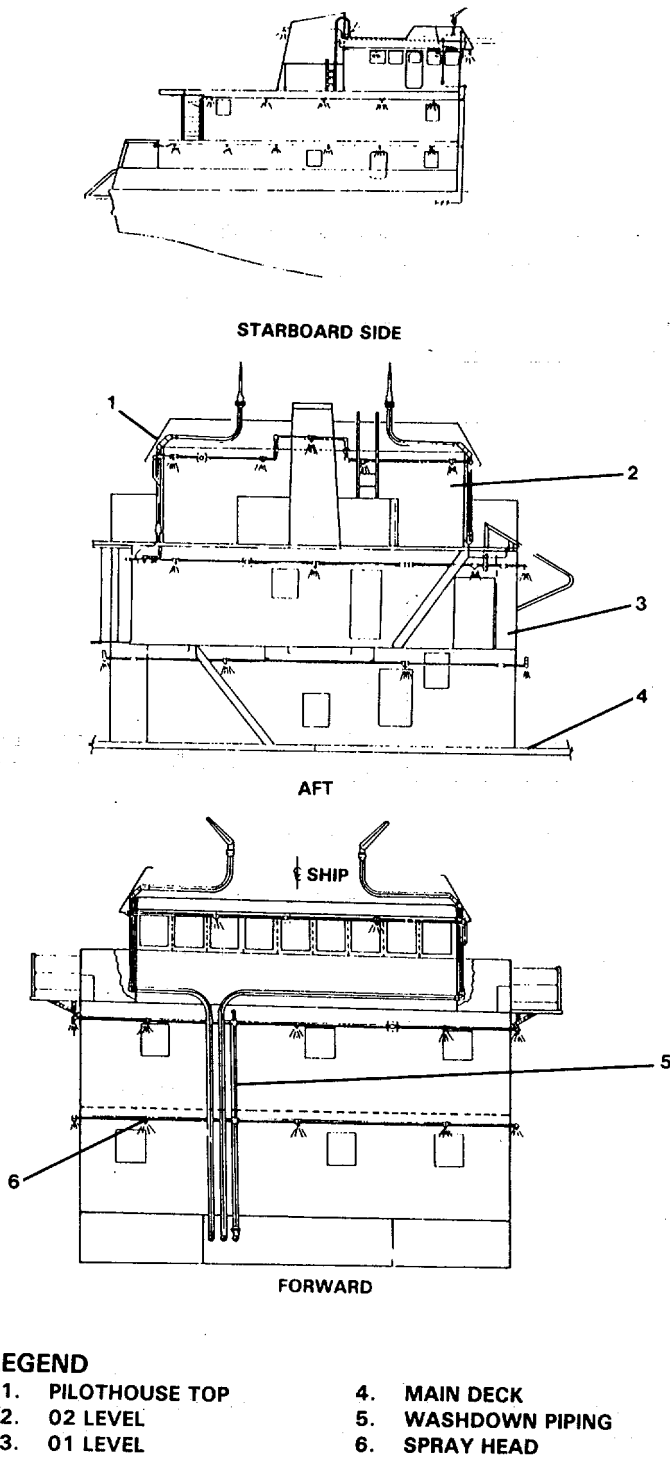

**LEGEND**

- |                   |                    |
|-------------------|--------------------|
| 1. PILOTHOUSE TOP | 4. MAIN DECK       |
| 2. O2 LEVEL       | 5. WASHDOWN PIPING |
| 3. O1 LEVEL       | 6. SPRAY HEAD      |

FIGURE 1-36. Countermeasure Washdown.

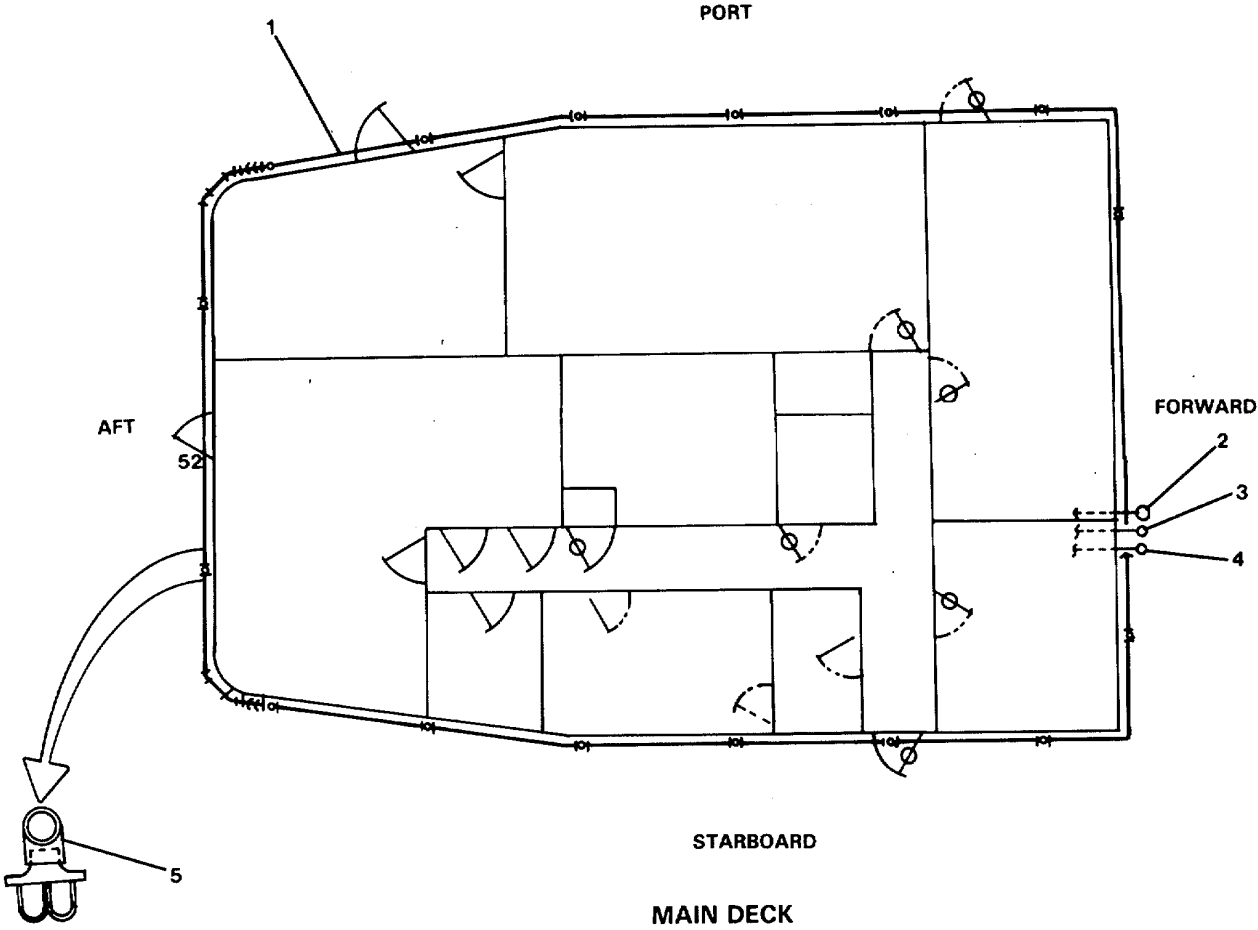

- LEGEND**
- |   |  |
|---|--|
| 1. COUNTERMEASURE WASHDOWN SUPPLY       | 3. FIRE MONITOR SUPPLY RISER (PORT)      |
| 2. COUNTERMEASURE WASHDOWN SUPPLY RISER | 4. FIRE MONITOR SUPPLY RISER (STARBOARD) |
|   | 5. SPRAY HEAD                            |

FIGURE 1-37. Fire Monitor and Countermeasure Washdown Piping System - Main Deck.

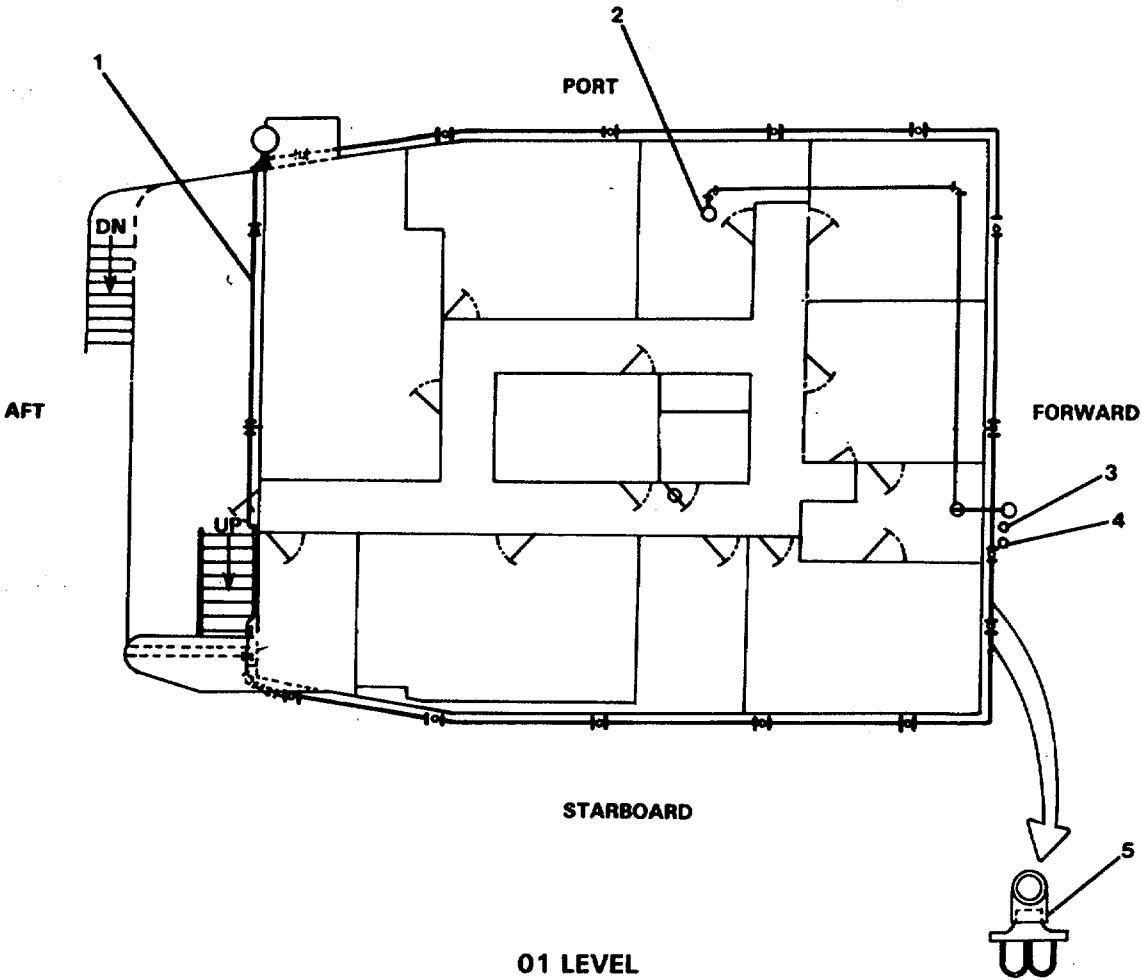

**LEGEND**

- |  |                                   |
|--|-----------------------------------|
| 1. COUNTERMEASURE WASHDOWN SUPPLY                | 3. FIRE MONITOR RISER (PORT)      |
| 2. COUNTERMEASURE WASHDOWN SUPPLY FROM MAIN DECK | 4. FIRE MONITOR RISER (STARBOARD) |
|  | 5. SPRAY HEAD                     |

FIGURE 1-38. Fire Monitor and Countermeasure Washdown Piping System - 01 Level.



**1-30. Electrical System** The electrical system distributes 240 Vac, 120 Vac, and emergency power throughout the ship. 240 Vac, 3-phase, 60 Hz power is received from the power generation system ship's service diesel generator sets and routed via the main ship's service switchboard and the emergency switchboard via the emergency switchboard bus tie, to selected equipment panels. 240 Vac power is also provided by the main switchboard to a stepdown isolation transformer providing power to the 120 Vac distribution panel. This panel distributes 120 Vac power to a quarters heating panel, galley power panel, and lighting panels. Essential equipment and systems ties into the emergency switchboard normally receive power from the emergency switchboard via the bus tie. When 240 Vac power is lost, these equipments and systems receive 240 Vac power from the emergency diesel generator set through the emergency switchboard. The emergency switchboard also provides 120 Vac power through stepdown transformers to a 120 Vac distribution panel. This panel provides 120 Vac power to the emergency switchboard battery charger, which charges the emergency switchboard 24 Vdc batteries, providing voltage to the 24 Vdc distribution panel. This panel provides 24 Vdc power to those systems required to maintain propulsion control, and communication, when tied to shore power through the shore power box, power distribution is the same as provided for primary power. No components are grounded to the hull. All electrical leads go from a panel to the equipment energized and back to the panel.

**1-31. Fresh Water Piping System** The fresh water piping system provides cold and hot potable water throughout the LCU. System control is maintained through a combination of valves as shown in FIGURE 1-39. The system consists of two reverse osmosis watermakers, two fresh water (FW) pumps and pressure switches, a pressure tank, hot water heater, and fresh water tank level indicator transmitters. Also included is a hot water booster pump and hot water booster heater for the Gaylord Hood. The FW tanks are filled and vented through fill and vent connections on the main weather deck. Each FW tank has a drain to the bilge. In addition to the potable water system, cold fresh water (CFW) is supplied to the fresh water cooling piping system.

a. Reverse Osmosis Watermakers Two reverse osmosis (RO) watermakers take seawater from the sea chest and, through the reverse osmosis process, separate brine and foreign matter from the seawater and supply fresh water to the port and starboard fresh water tanks. Brine is discharged overboard from the RO watermakers. Power is supplied to the fresh watermakers from the AUX MCHRY MCC and can be started and stopped from the engine room console and at the watermaker units.

b. FW Pumps No. 1 and No. 2 Two FW pumps draw CFW from the port and starboard FW tanks and route the CFW under pressure to the hydropneumatic pressure tank, which maintains CFW pressure throughout the system. Power for the pumps is supplied from the main switchboard 240 Vac distribution, and controlled by start and stop pushbuttons on the engine room console and by pressure switches. One pump (main) is on line and the other (standby) is in reserve.

c. Pressure Switches Each FW pump pressure switch automatically turns on its respective FW pump when pressure drops below to the cut-in setpoint (pump 1-35 psi, pump 2-30 psi). Each FW pump pressure switch automatically turns off its respective FW pump when pressure exceeds 60 psi.

d. Pressure Tank The hydropneumatic tank maintains CFW supply pressure for the system. Pressurized CFW is supplied from the pressure tank to various points throughout the ship and to the hot water heater.

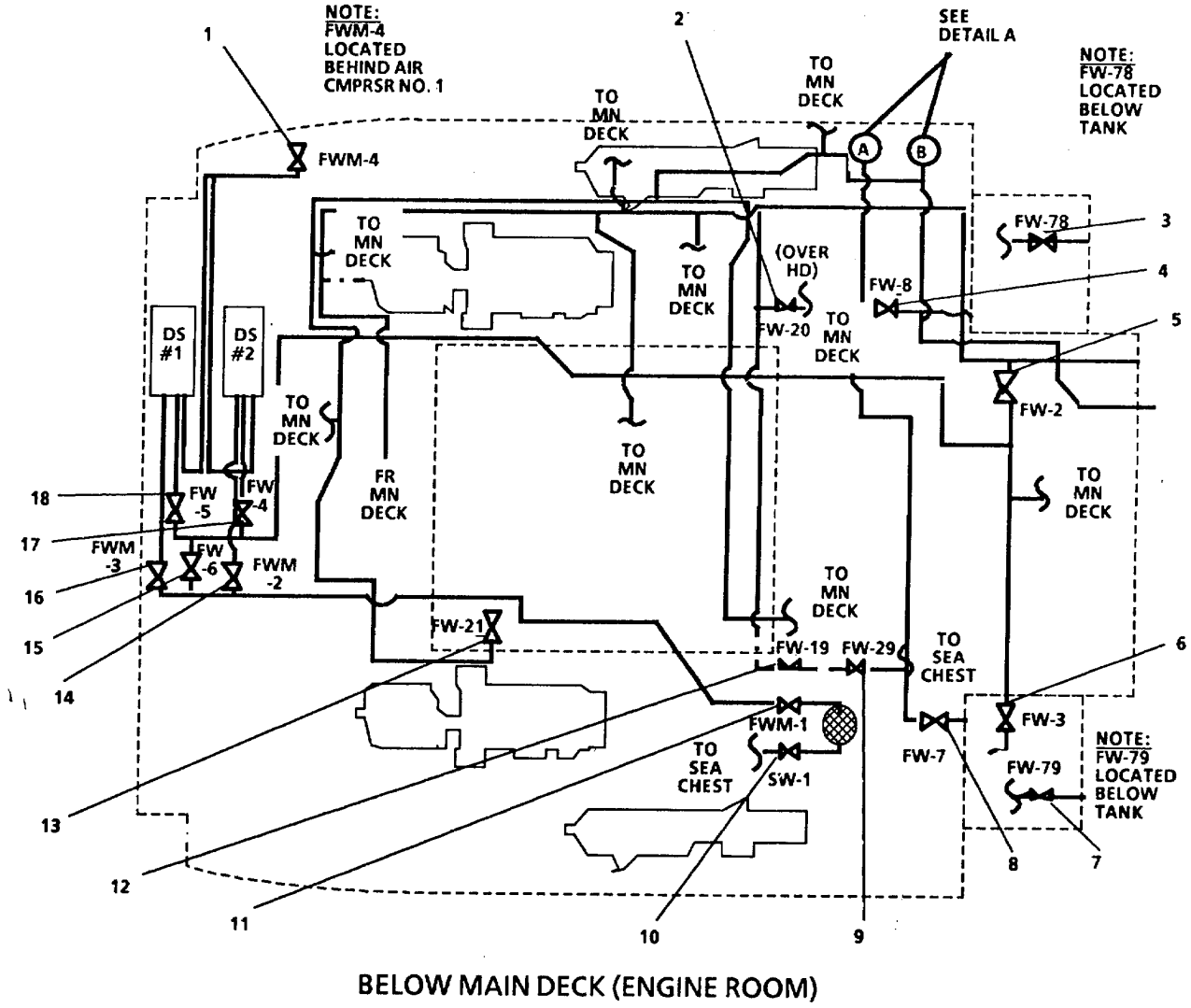

FIGURE 1-39. Fresh Water Piping System (Sheet 1 of 8).

DETAIL A

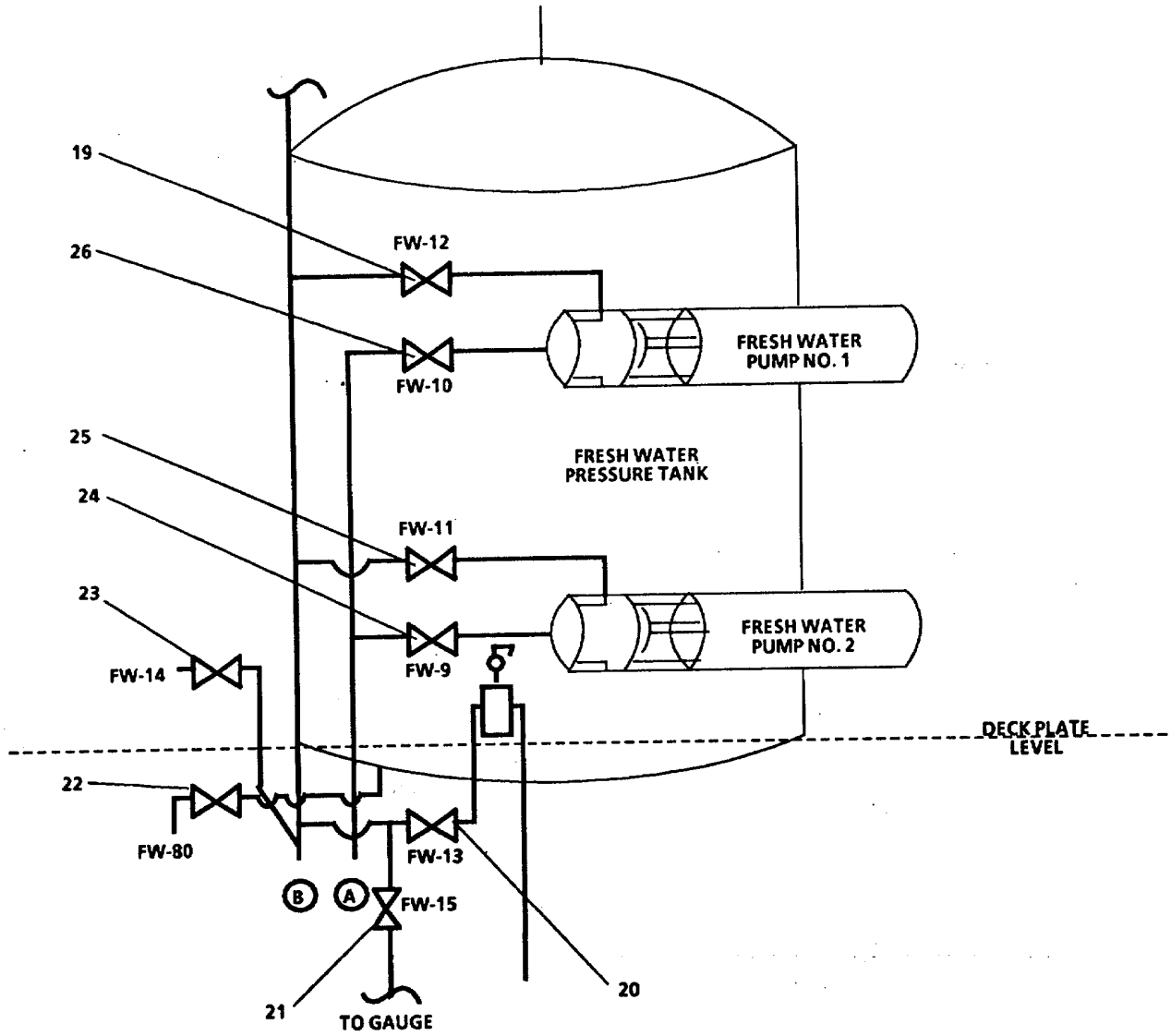
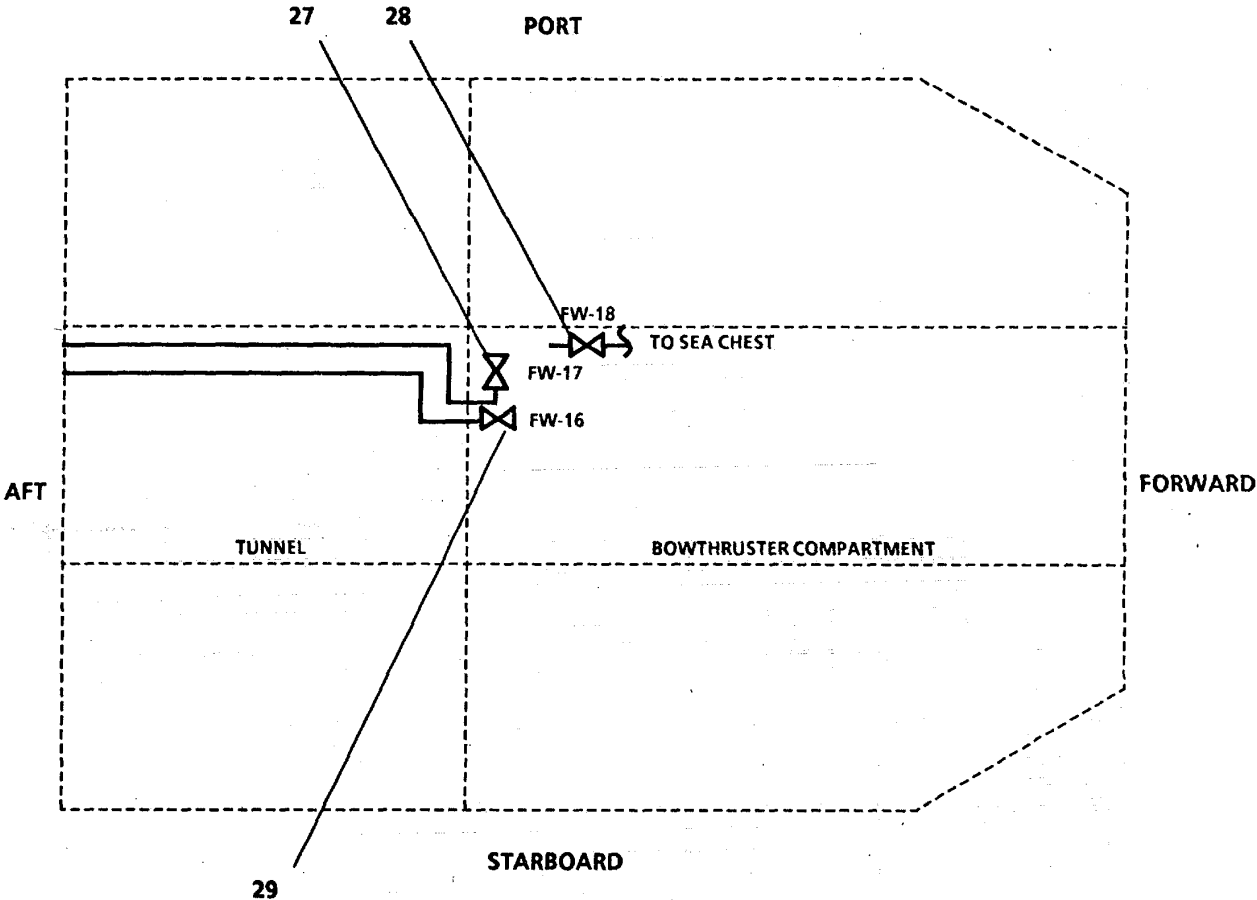

FIGURE 1-39. Fresh Water Piping System (Sheet 2 of 8).



Below Main Deck (Tunnel and Bowthruster Compartment)

FIGURE 1-39. Fresh Water Piping System (Sheet 3 of 8).

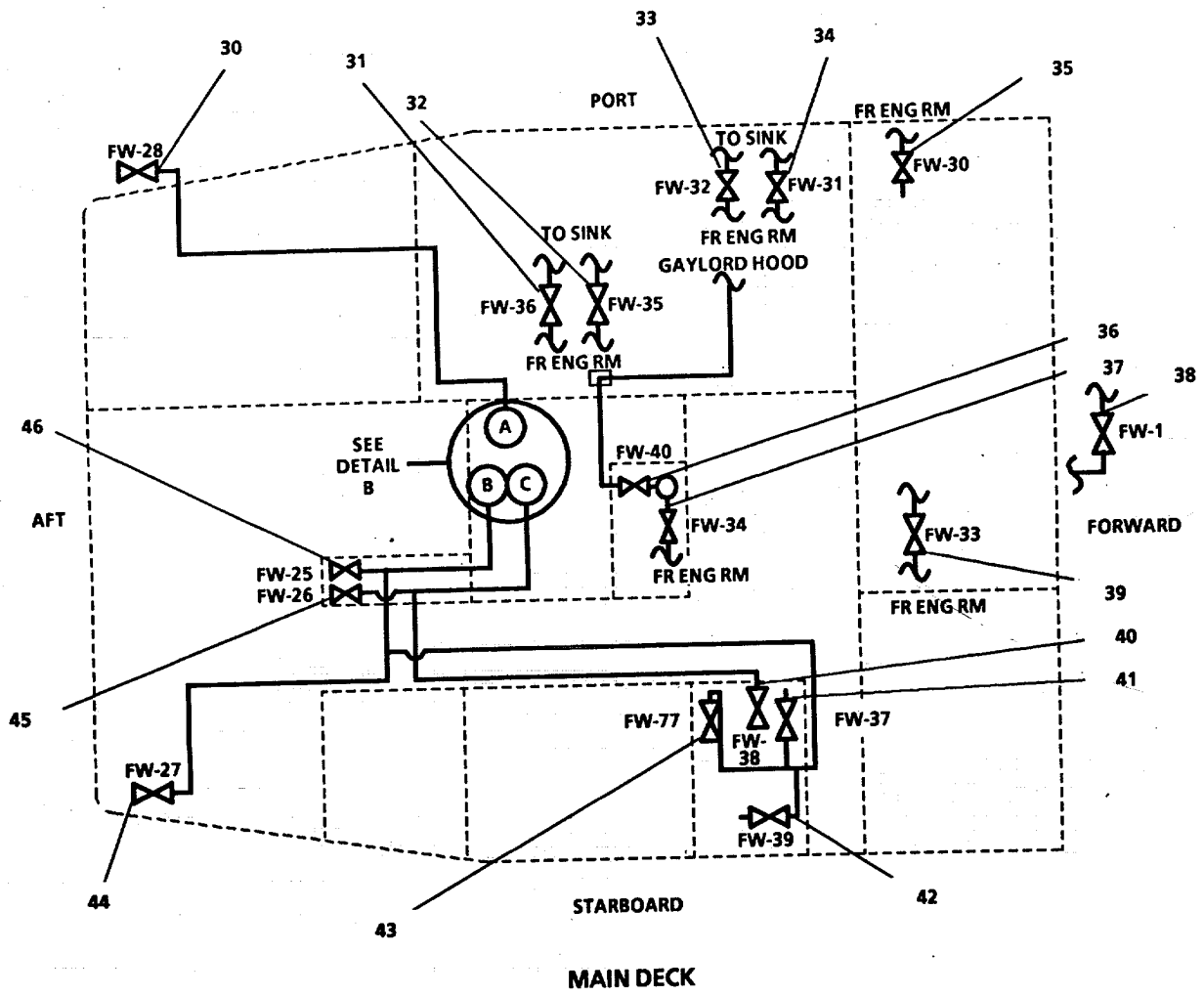

FIGURE 1-39. Fresh Water Piping System (Sheet 4 of 8).

DETAIL B

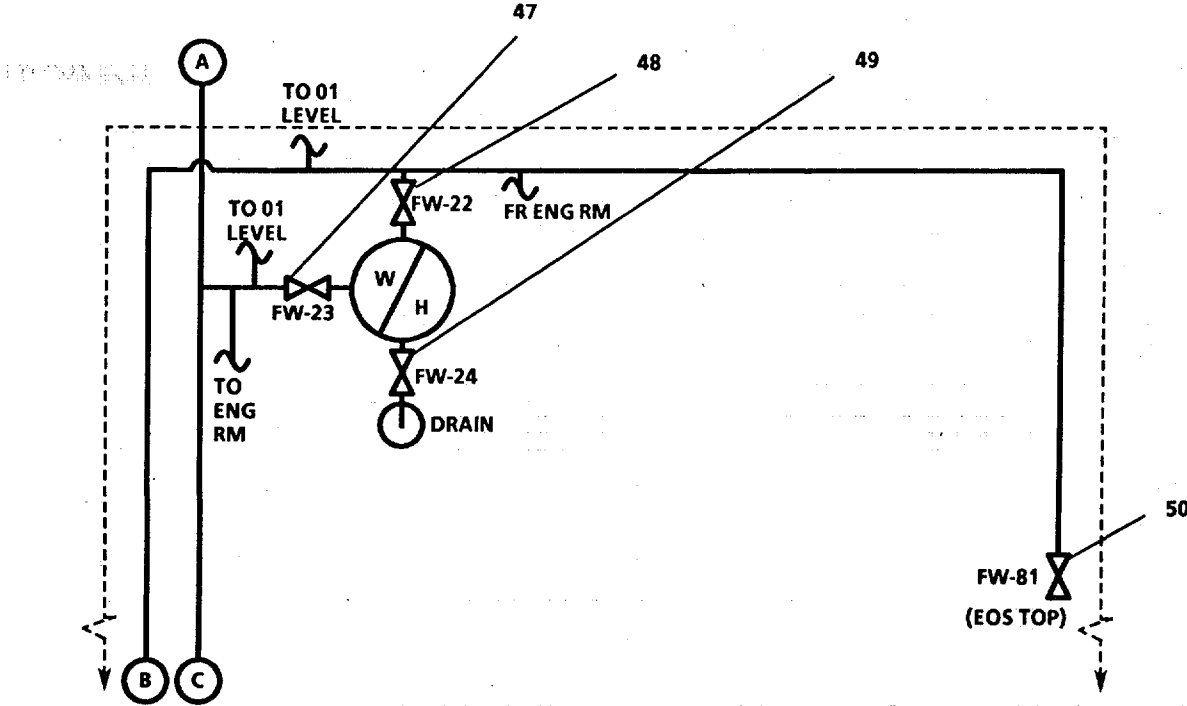

FIGURE 1-39. Fresh Water Piping System (Sheet 5 of 8).

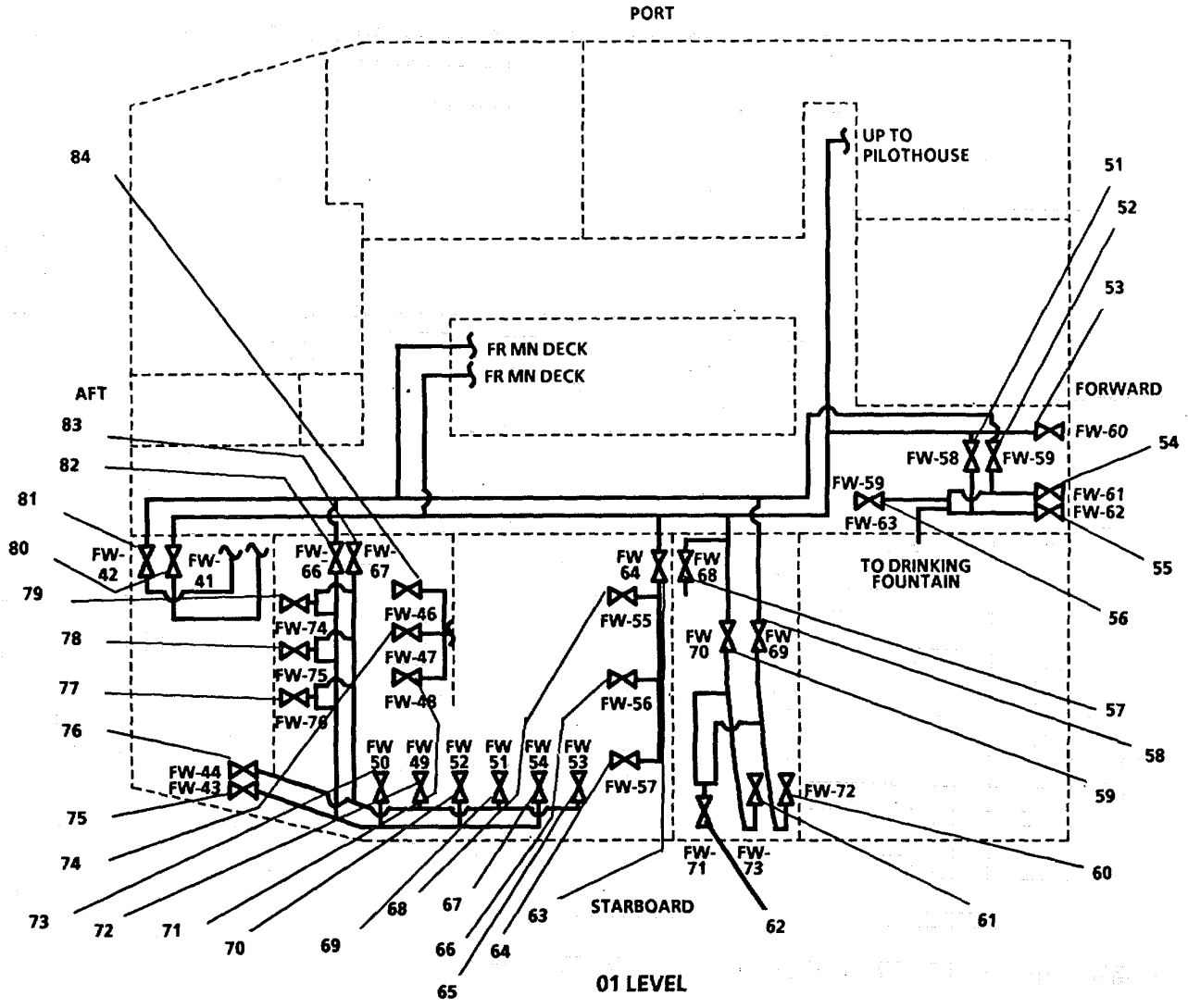

FIGURE 1-39. Fresh Water Piping System (Sheet 6 of 8).

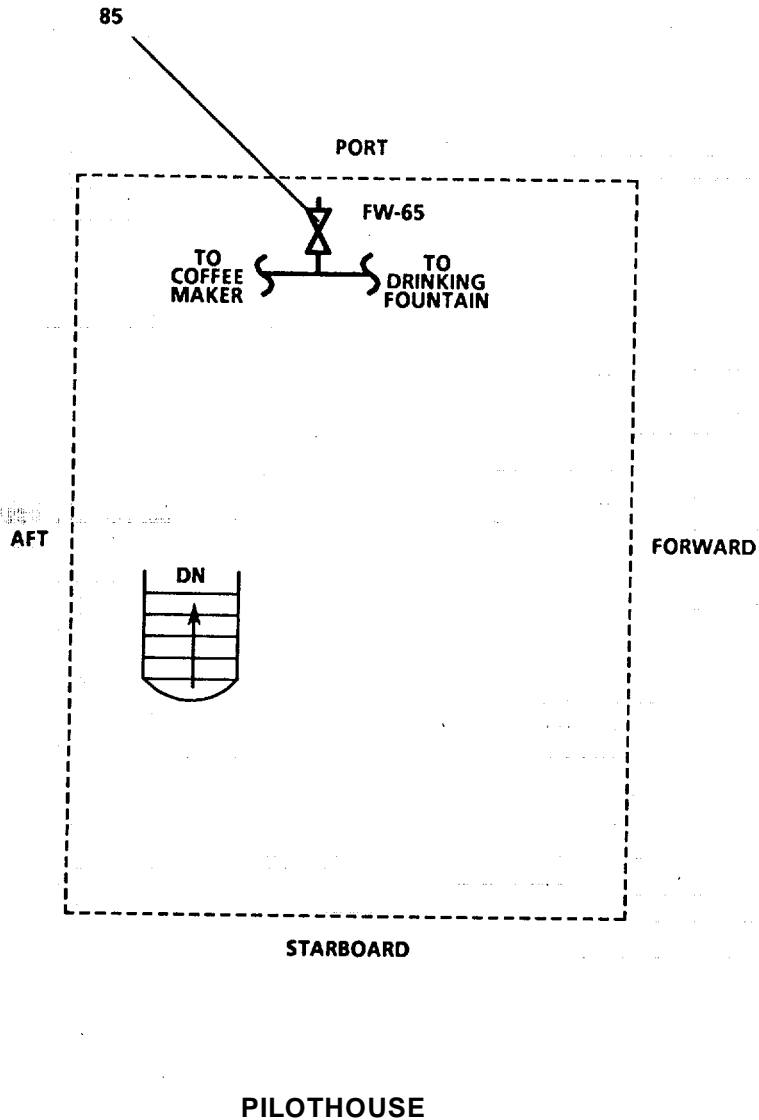

FIGURE 1-39. Fresh Water Piping System (Sheet 7 of 8).



**LEGEND**

- |   |                                  |
|---|----------------------------------|
| 1. FWM-4, BRINE OVBD DISCH                          | 43. FW-77, SUPPLY TO SH          |
| 2. FW-20, HOT FWTO DISHWASHER                       | 44. FW-26, HOTFWTOCLKRSINK       |
| 3. FW-78, DRAIN-TKFW-6P                             | 46. FW-25, COLD FWTO CG LKR SINK |
| 4. FW-8, ISLN/SUCT-TK FW-6P                         | 47. FW-23, HOT FW DISCH FR WTR   |
| HTR   |                                  |
| 4. FW-8, FLISLN/SUCTK FW-6P                         | 48. FW-22, COLD FW TO WTR HTR    |
| 5. FW-2, FILL ISLN-TK FW-6P                         | 49. FW-24, WTR HTR DRAIN         |
| 6. FW-3, FILL ISLN-TK FW-6S                         | 50. FW-81, EXP TK FILL           |
| 7. FW-79, DRAIN-TK FW-6S                            | 51. FW-58, COLD FW ISLN          |
| 8. FW-7, ISLN/SUCT-TK                               | 52. FW-59, HOT FW ISLN           |
| 9. FW-29, SEA CHEST-HOT FW CONNECTION               | 53. FW-60, SUPPLY TO WC          |
| 10. SW-1, SUPPLY TO PUMP                            | 54. FW-61, SUPPLYTOWC            |
| 11. FWM-1. ISLN-SW SUPPLY TO FW MAKERS              | 55. FW-62, COLD FWTO SINK        |
| 12. FW-19, HOT FW HOSE CONN                         | 56. FW-63, SUPPLYTOSH            |
| 13. FW-21, COLD FWTO DF & COFFEE MAKER-ENG RM       | 57. FW-68, SUPPLY TO WC          |
| 14. FWM-2, SW SUPPLY TO FW MAKER NO. 2              | 58. FW-69, COLD FW ISLN          |
| 15. FW-6, FW SAMPLE STA                             | 59. FW-70, SLN-HOT FW            |
| 16. FWM-3, SW SUPPLY TO FW MAKER NO.1               | 60. FW-72, COLDFWTOSINK          |
| 17. FW-4, FW MAKER NO. 2 SUPPLY TO FWTKS            | 61. FW-73, HOTFWTOSINK           |
| 18. FW-5, FW MAKER NO. 1 SUPPLY TO FW TKS           | 62. FW-71, SUPPLY TO SH          |
| 19. FW-12, FW PUMP NO. 2 DISCH                      | 63. FW-64, ISLN-WC               |
| 20. FW-13, FW PRESS TK ISLN                         | 64. FW-57, SUPPLY TO WC          |
| 21. FW-1 S5, CO PRESS GAGE-FW SYS                   | 65. FW-53, CO F TOSINK           |
| 22. FW-80, PRESSURE TANK DRAIN                      | 66. FW-56, SUPPLY TO WC          |
| 23. FW-14, COLD FW HOSE CONN                        | 66. FW-56, SUPPLY TO WC          |
| 24. FW-9, FW PUMP NO. 1 SUCT FR FW TANKS            | 67. FW-54, HOT FW TO SINK        |
| 25. FW-11, FW PUMP NO. 1 DISCH                      | 69. FW-51, COLD FWTO SINK        |
| 26. FW-10, FW PUMP NO. 2 SUCT FR FWTKS              | 70. FW-52, HOTFWTOSINK           |
| 27. FW-17, HOT FW HOSE CONN                         | 71. FW-48, SUPPLYTOURINAL        |
| 28. FW-18, SEA CHEST- HOT FW CONN                   | 72. FW-49, COLD FW TO SINK       |
| 29. FW-16, COLD FW HOSE CONN                        | 73. FW-50, HOT FWTO SINK         |
| 30. FW-28, HOT FW WASHDOWN                          | 74. FW-47, SUPPLY TO URINAL      |
| 31. FW-36, HOT FWTO AFT GALY SINK                   | 75. FW-43, COLD FW TO WASHER     |
| 32. FW-35, COLD FW TO AFT GALY SIN K                | 76. FW-44, HOTFWTOWASHER         |
| 33. FW-32, HOT FW TO FWD GALY SINK                  | 77. FW-76, SUPPLYTOSH            |
| 34. FW-31, COLD FW TO FWD GALY SINK                 | 78. FW-75, SUPPLYTOSH            |
| 35. FW-30, COLD FW TO DF (MESS DK)                  | 79. FW-74, SUPPLY TO SH          |
| 36. FW-40, GAYLORD PUMP DISCH                       | 80. FW-41, COLD FTO LAU SINK     |
| 37. FW-34, COLD FW TO GAYLORD HOOD PUMP             | 81. FW-42, HOT TO LAU SINK       |
| 38. FW-1, FILL CONN-FW TKS                          | 82. FW-66, ISLN-HOT F            |
| 39. FW-33, COLD FW TO BVGE & COFFEE MAKER (MESS DK) | 83. FW-67, ISLN-OLD FW           |
| 40. FW-38, HOT FWTO SICKBAY SINK                    | 84. FW-46, SUPPLY TO URINAL      |
| 41. FW-37, COLD FW TO SICKBAY SINK                  | 85. FW-65, COLD FW TO DF         |
| 42. FW-39, SUPPLY TO WC                             |                                  |

FIGURE 1-39. Fresh Water Piping System (Sheet 8 of 8).

e. Hot Water Heater The hot water heater heats the CFW supply and maintains its setpoint temperature. Power for the hot water heat is supplied from the main switchboard 240 Vac distribution panel and controlled by a disconnect switch adjacent to the heater. Hot fresh water (HFW) from the heater is supplied to the booster pump.

f. Booster Pump The booster pump maintains HFW pressure required for the Gaylord Hood system.

g. Booster Heaters Two booster heaters provide an increase in HFW temperature for use in the galley (dishwasher and hood). Both booster heaters are supplied with power from the GALLEY POWER PANEL P202.

h. Tank Level Indicator Transmitters Each FW tank contains a tank level indicator transmitter which sends a tank level signal to the gauge board in the engine room which indicates each FW tank level.

**1-32. Bilge/Ballast and Firemain Piping System** The bilge/ballast and firemain piping systems remove accumulated water from the bilges, transfers seawater to and from seawater ballast tanks, and supplies seawater to the firemain, countermeasure washdown (CMWD), and AFFF foam proportioners.

a. Bilge/Ballast Piping System The bilge/ballast piping system (FIGURE 1-40) draws bilge water from selected ship bilges and discharges it overboard. The system also draws seawater from the sea chest and distributes it to selected ballast (seawater) tanks and draws seawater from the ballast tanks and discharges it overboard, or to another ballast tank. In an extreme emergency, the bilge/ballast piping system can be aligned to supply ballast water to the fire main. System control is maintained through a combination of valves as shown in FIGURE 1-40. The system consists of the bilge/ballast pump, bilge manifold, and ballast manifold. Power for the bilge/ballast pump is supplied from the main switchboard 240 Vac distribution panel and controlled by start and stop pushbuttons on the engine room console.

b. Fire Main and Foam Piping System The fire main and foam piping system (FIGURE 1-41) draws seawater from the sea chest to pressurize the fire main, countermeasure washdown (CMWD), and AFFF foam proportioners. System control is maintained through a combination of valves as shown in FIGURE 1-41. The system consists of fire pumps No. 1 and No. 2, and auxiliary fire pump. The fire main supplies seawater to fire stations, the countermeasure washdown station, and the AFFF foam proportioners. Power to fire pumps No. 1 and No. 2 is supplied by the main switchboard 240 Vac distribution panel. Control of the pumps is provided from start and stop pushbuttons adjacent to the pumps or from stop and start pushbuttons on the engine room console. The auxiliary fire pump will also pressurize the fire main. This pump is powered by the bowthruster/auxiliary fire pump diesel engine.

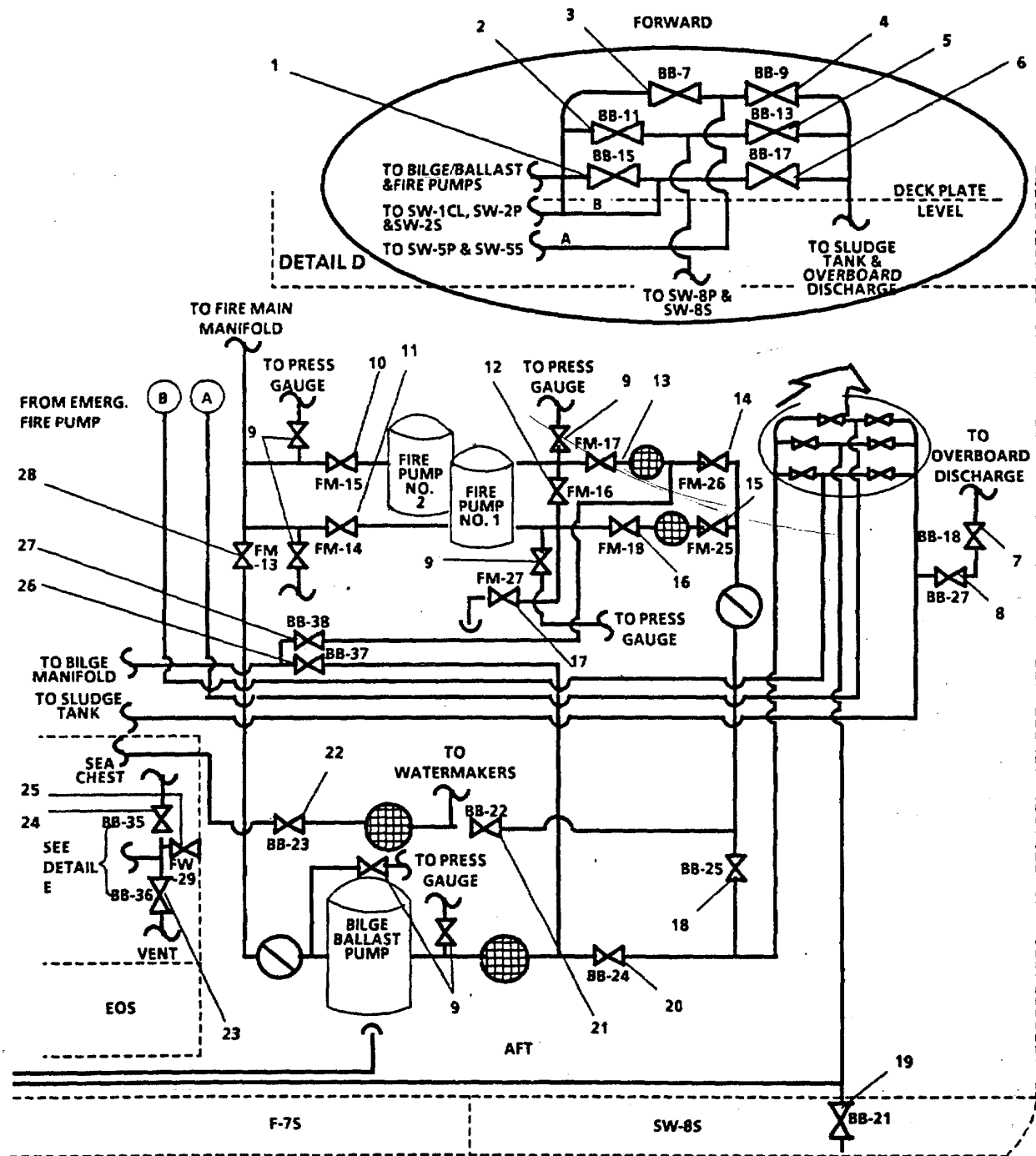

Figure 1-40. Bilge/Ballast Piping System (Sheet 1 of 4).

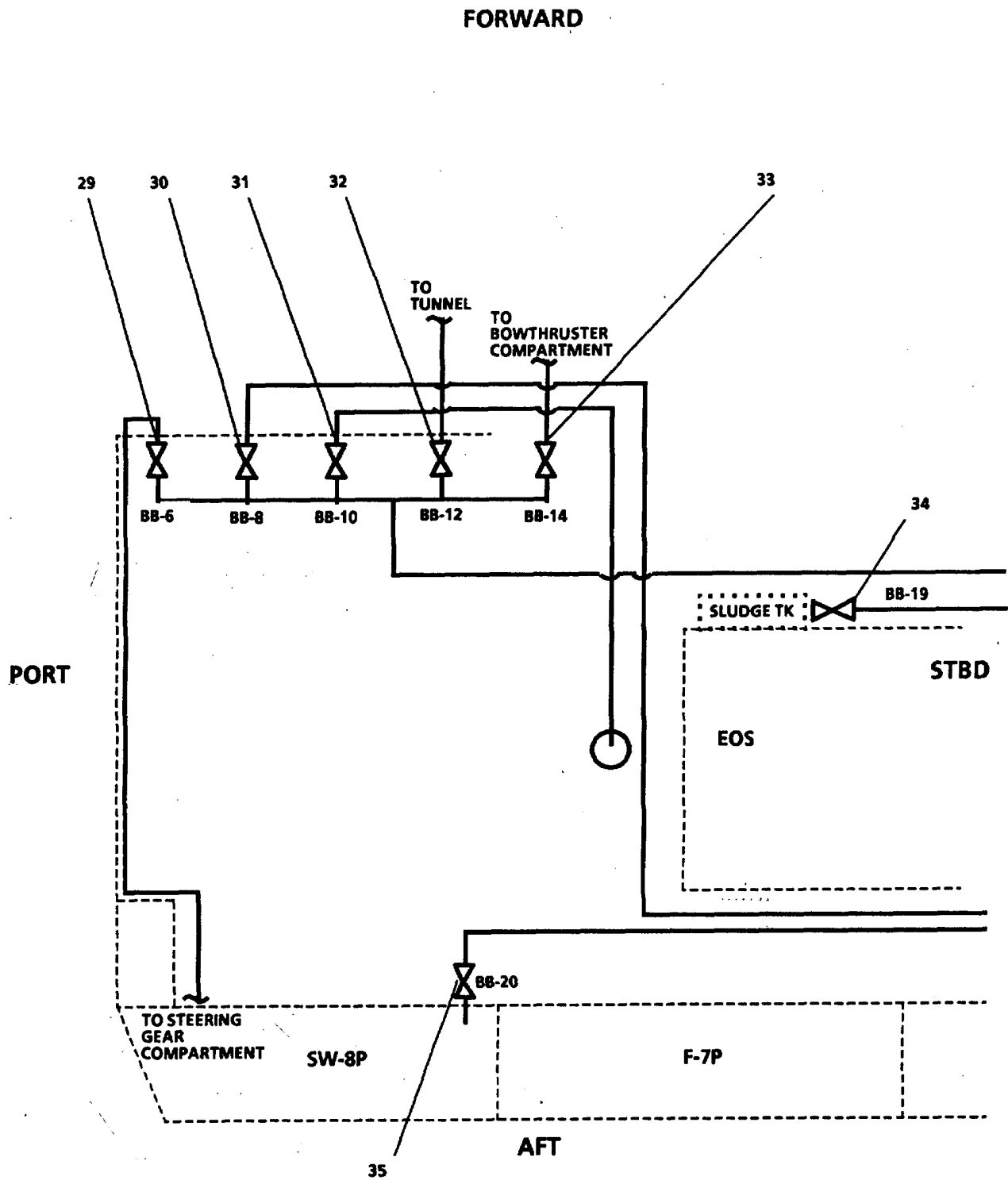

FIGURE 1-40. Bilge/Ballast Piping System (Sheet 2 of 4).

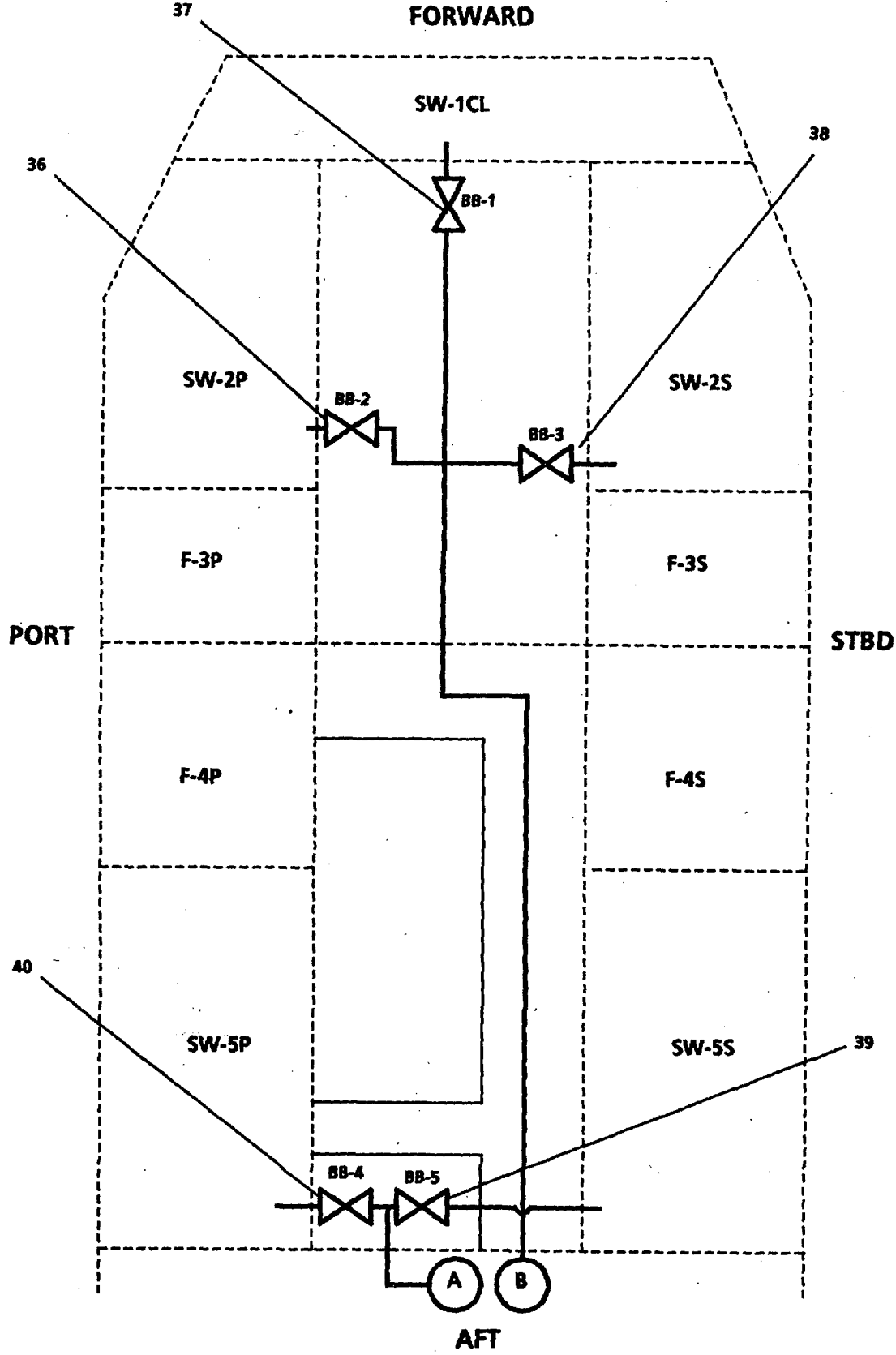
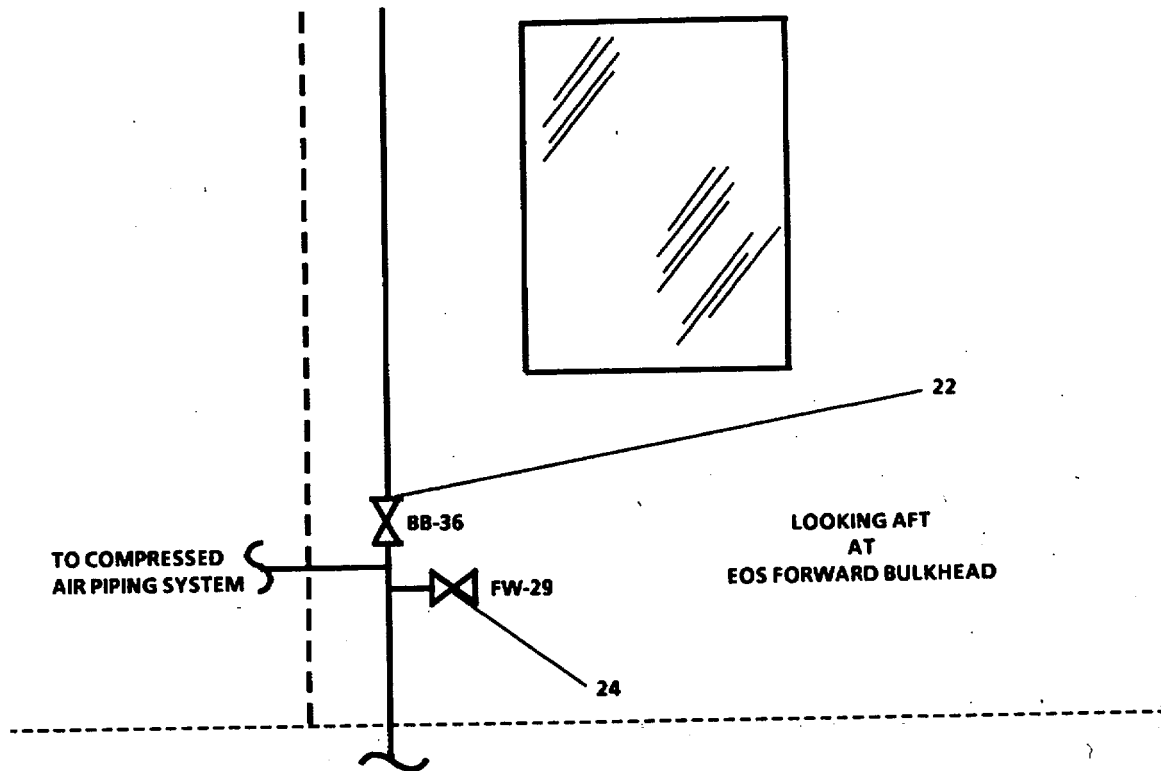

Figure 1-40. Bilge/Ballast Piping System (Sheet 3 of 4).  
1-120

DETAIL E



LEGEND

- |   |   |
|---|---|
| <p>1. BB-15, SUCT FR SW-1 &amp; SW-2S &amp; SW-2P<br/>                 2. BB-11, SUCT FR SW-8S &amp; SW-8P<br/>                 3. BB-7, SUCT FR SW-5S &amp; SW-5P<br/>                 4. BB-9, SUPPLY TO SW-5S &amp; SW-5P<br/>                 5. BB-13, SUPPLY TO SW-8S &amp; SW-8P<br/>                 6. BB-17, SUPPLY TO SW-1 &amp; SW-2S &amp; SW-2P<br/>                 7. BB-18, TO OVBD DISCH<br/>                 8. BB-27, TO OVBD DISCH<br/>                 9. PRESSURE GAUGE ISOLATION<br/>                 10. FM-1 5, NO.2 FIRE PUMP DISCH<br/>                 11. FM-14, NO.1 FIRE PUMP DISCH<br/>                 12. FM-16, FIRE PUMP 1&amp;2 SUCT CROSS CONN<br/>                 13. FM-17, FIRE PUMP NO. 2 SUCT<br/>                 14. FM-26, NO. 2 FIRE PUMP STRAINER ISOLATION<br/>                 15. FM-25, NO. 1 FIRE PUMP STRAINER ISOLATION<br/>                 16. FM-18, FIRE PUMP NO.1 SUCT<br/>                 17. FM-27, ENG RM EMERG BILGE SUCT<br/>                 18. BB-25, ISLN-SEA CHEST<br/>                 19. BB-21, ISLN-TK SW-8S<br/>                 20. BB-24, SUCT-BILGE/BALLAST PUMP</p> | <p>21. BB-22, ISLN -SEA CHEST<br/>                 22. BB-23, SEA CHEST SUCT<br/>                 23. BB-36, SEACHEST VENT<br/>                 24. BB-35, SEACHEST VENT ISOLATION<br/>                 25. FW-29, SEA CHEST HOT FW CONN<br/>                 26. BB-37, CROSS CONN TO BILGE MANIFOLD<br/>                 27. BB-38, CROSS CONN FIRE PUMP SUCT TO BILGE MANIFOLD<br/>                 28. FM-13, FIREMAN &amp; BALLAST CROSS CONN<br/>                 29. BB-6, BILGE SUCT-STRG GR COMPT<br/>                 30. BB-8, BILGE SUCT-ENG RM STBD<br/>                 31. BB-10, BILGE SUCT-ENG RM PORT<br/>                 32. BB-12, BILGE SUCT-TUNNEL<br/>                 33. BB-14, BILGE SUCT BOWTHRUSTER ENG RM<br/>                 34. BB-19, DISCH TO SLUDG TK<br/>                 35. BB-20, ISLN-TK SW-BP<br/>                 36. BB-2, ISLNTKSW-2P<br/>                 37. BB-1, ISLNTKSW-1<br/>                 38. BB-3, ISLN TK SW-2S<br/>                 39. BB-5, ISLN TK SW-5S<br/>                 40. BB-, ISLN TK SW-5P2</p> |
|---|---|

FIGURE 1-40. Bilge/Ballast-Piping System (Sheet 4 of 4).

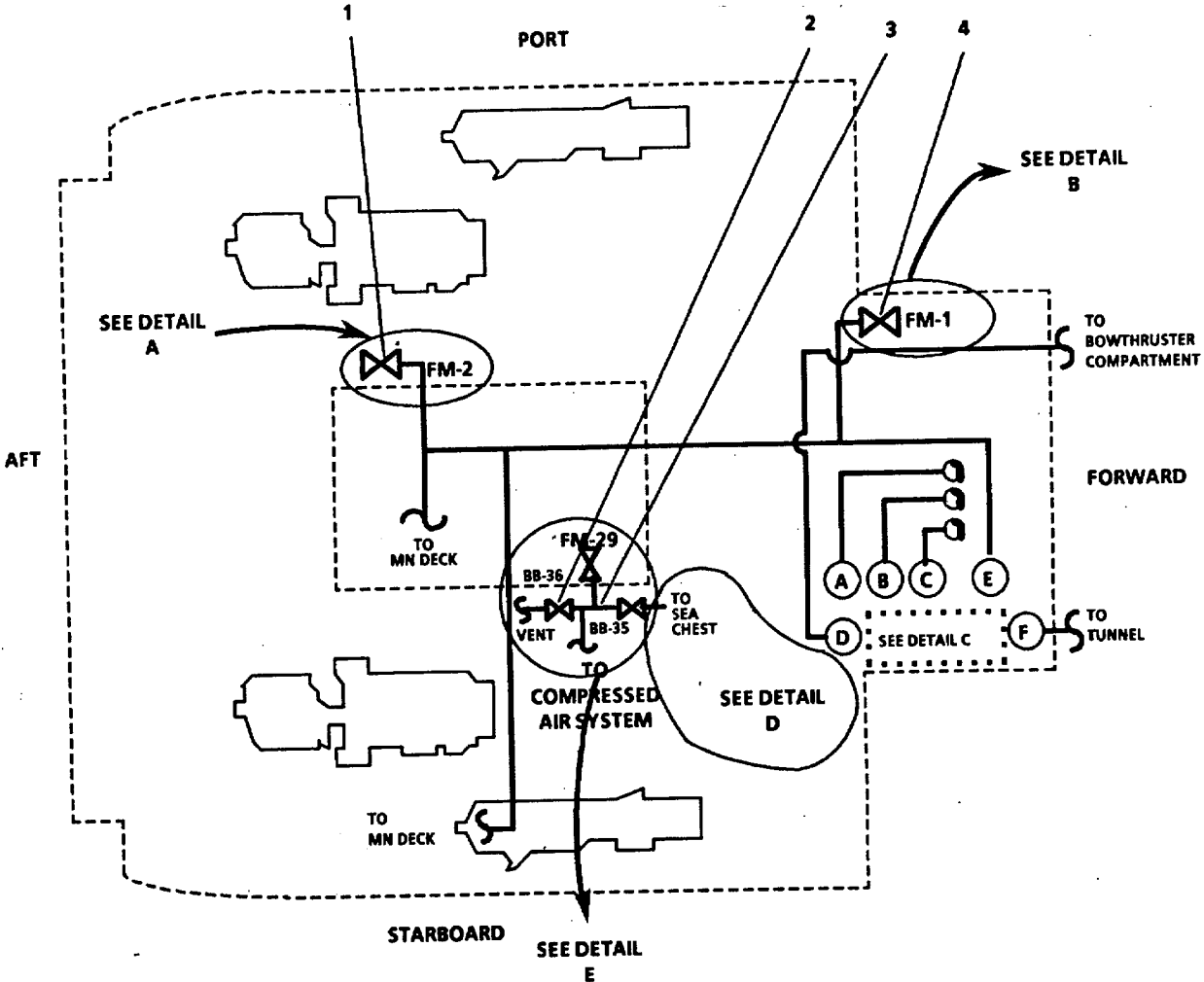

FIGURE 1-41. Fire Main and Foam Piping System (Sheet 1 of 12).

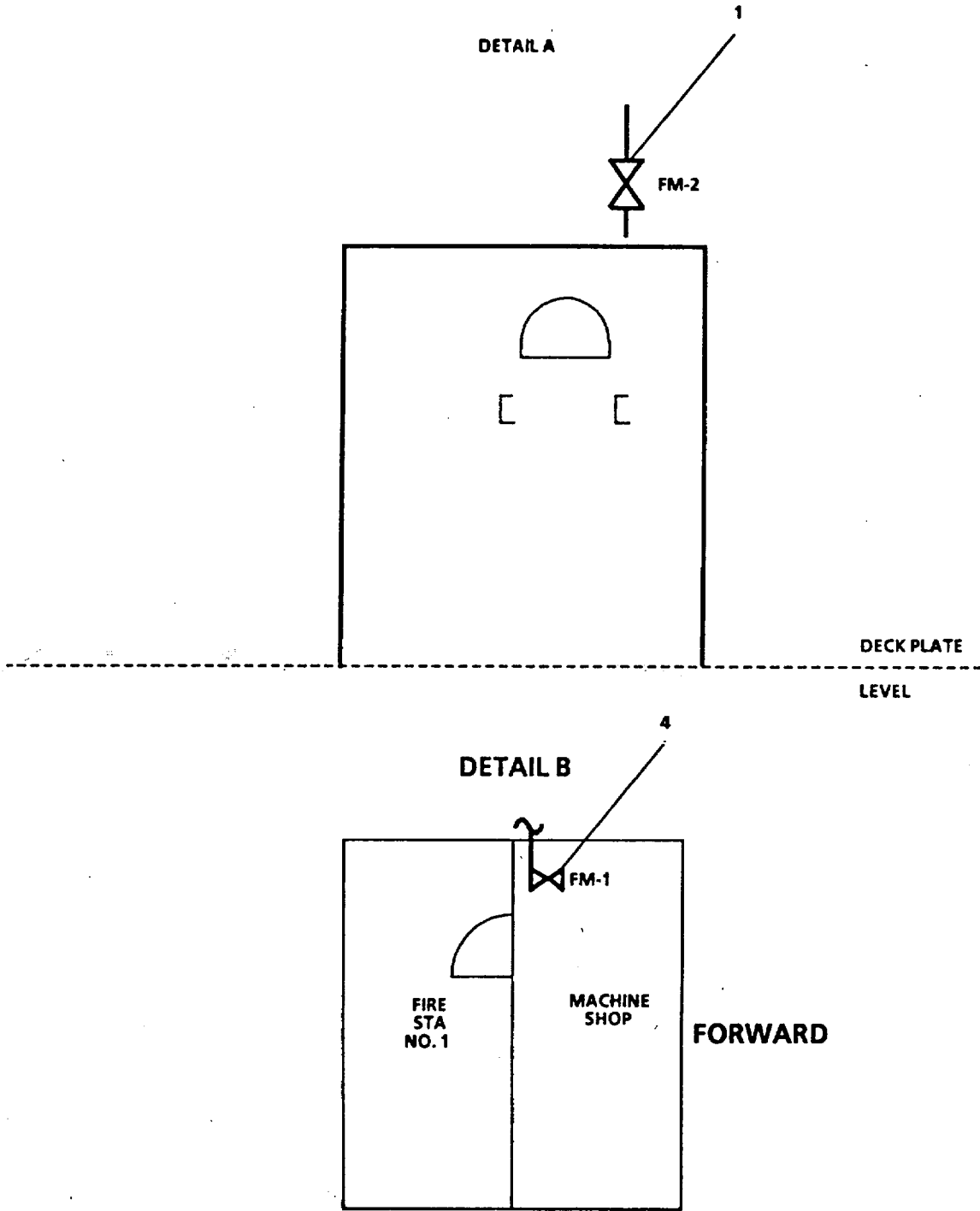
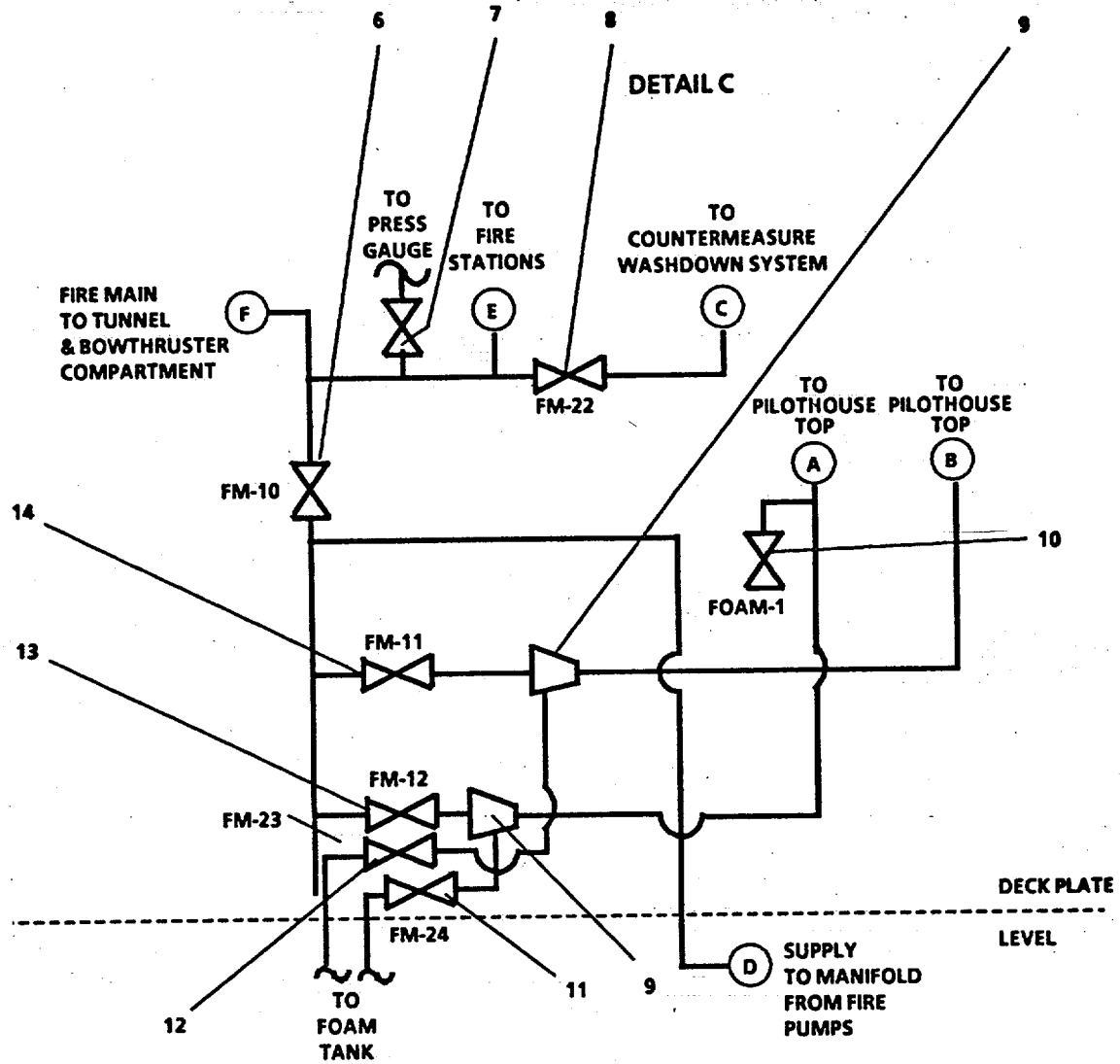

FIGURE 1-41. Fire Main and Foam Piping System (Sheet 2 of 12).





LOOKING STARBOARD AT PORT BULKHEAD OF STOREROOM

FIGURE 1-41. Fire Main and Foam Piping System (Sheet 3 of 12).

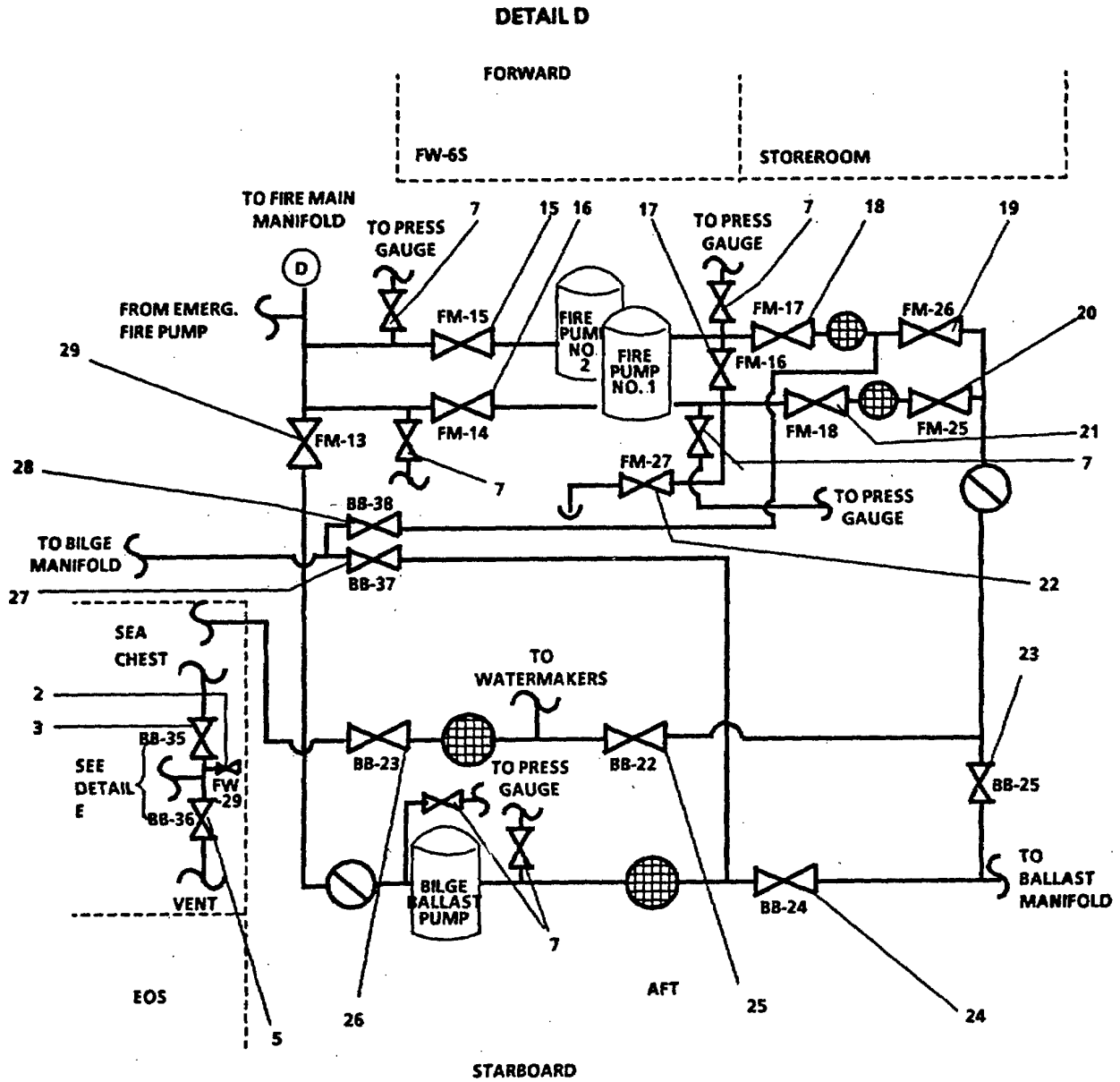

FIGURE 1-41. Fire Main and Foam Piping System (Sheet 4 of 12).

DETAIL

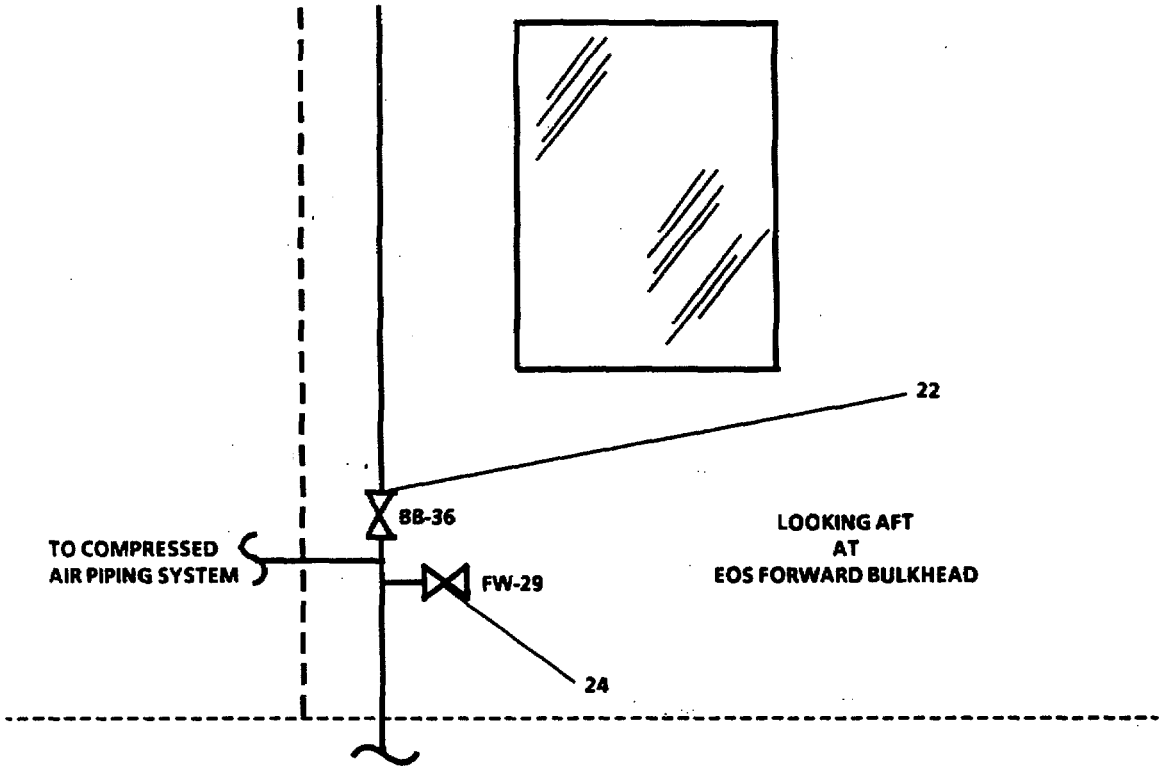

FIGURE 1-41. Fire Main and Foam Piping System (Sheet 5 of 12).

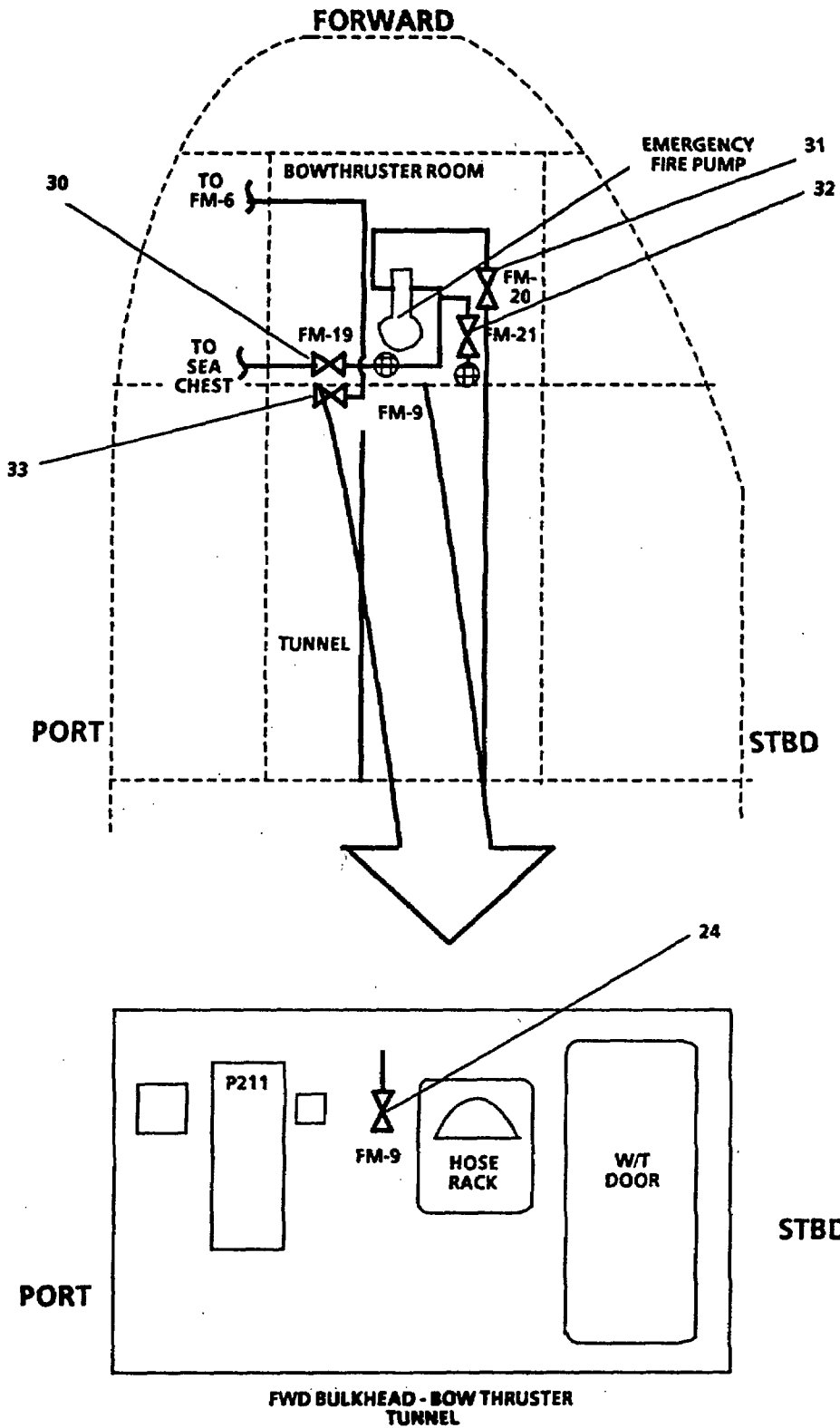

FIGURE 1-41. FIRE Main and Foam Piping System (Sheet 6 of 12).

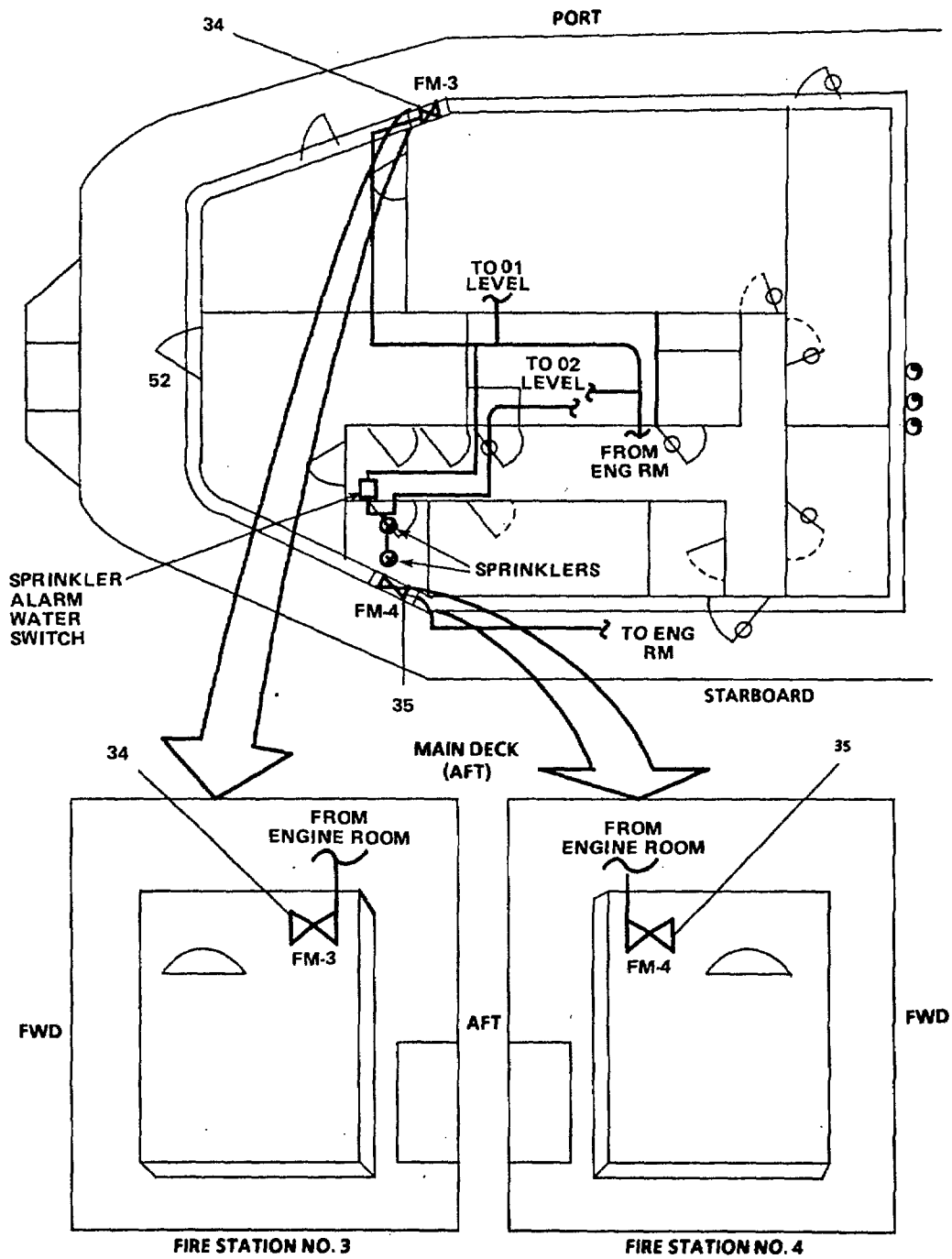

FIGURE 1-41. Fire Main and Foam Piping System (Sheet 7 of 12).

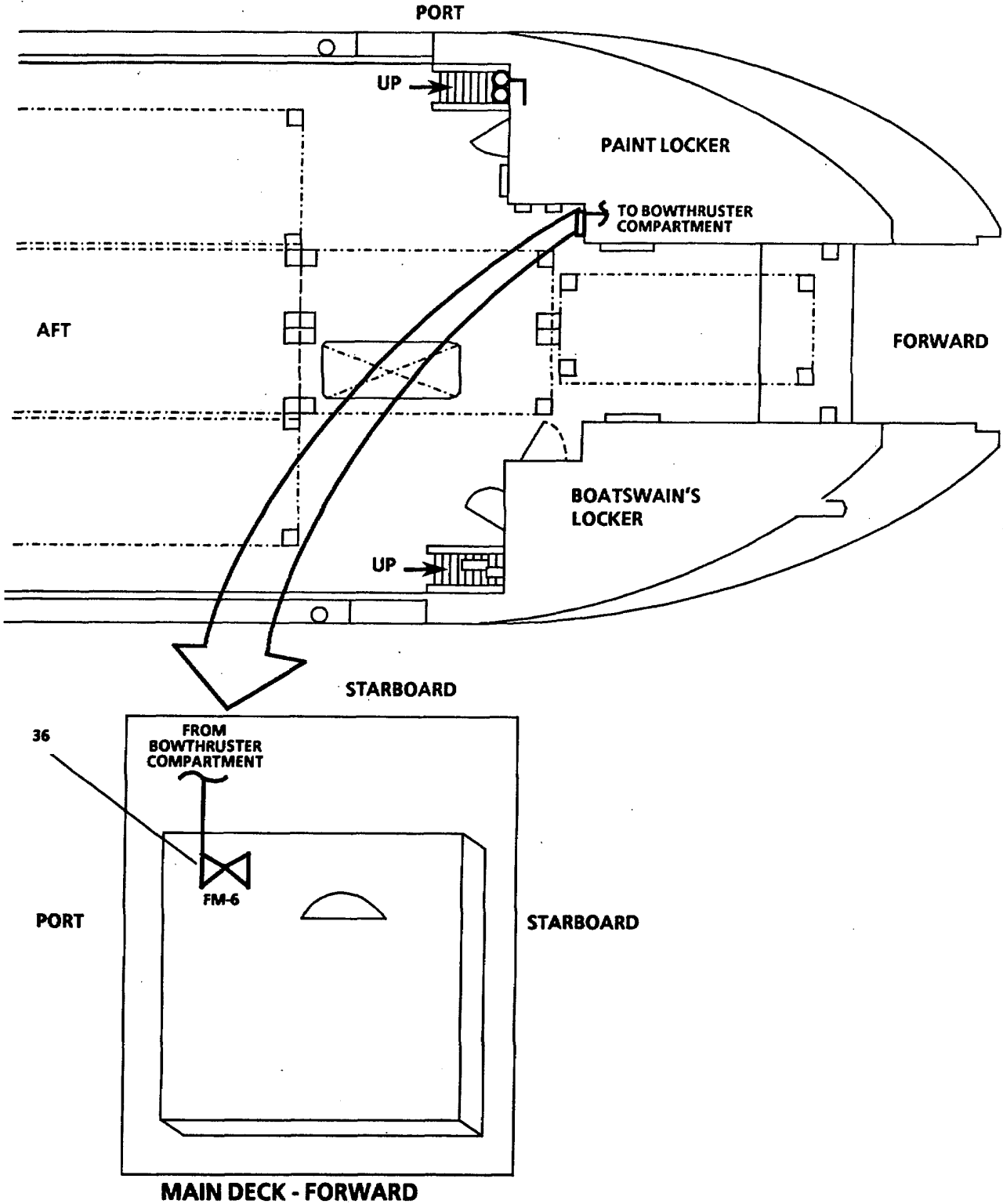

FIGURE 1-41. Fire Main and Foam Piping System (Sheet 8 of 12).

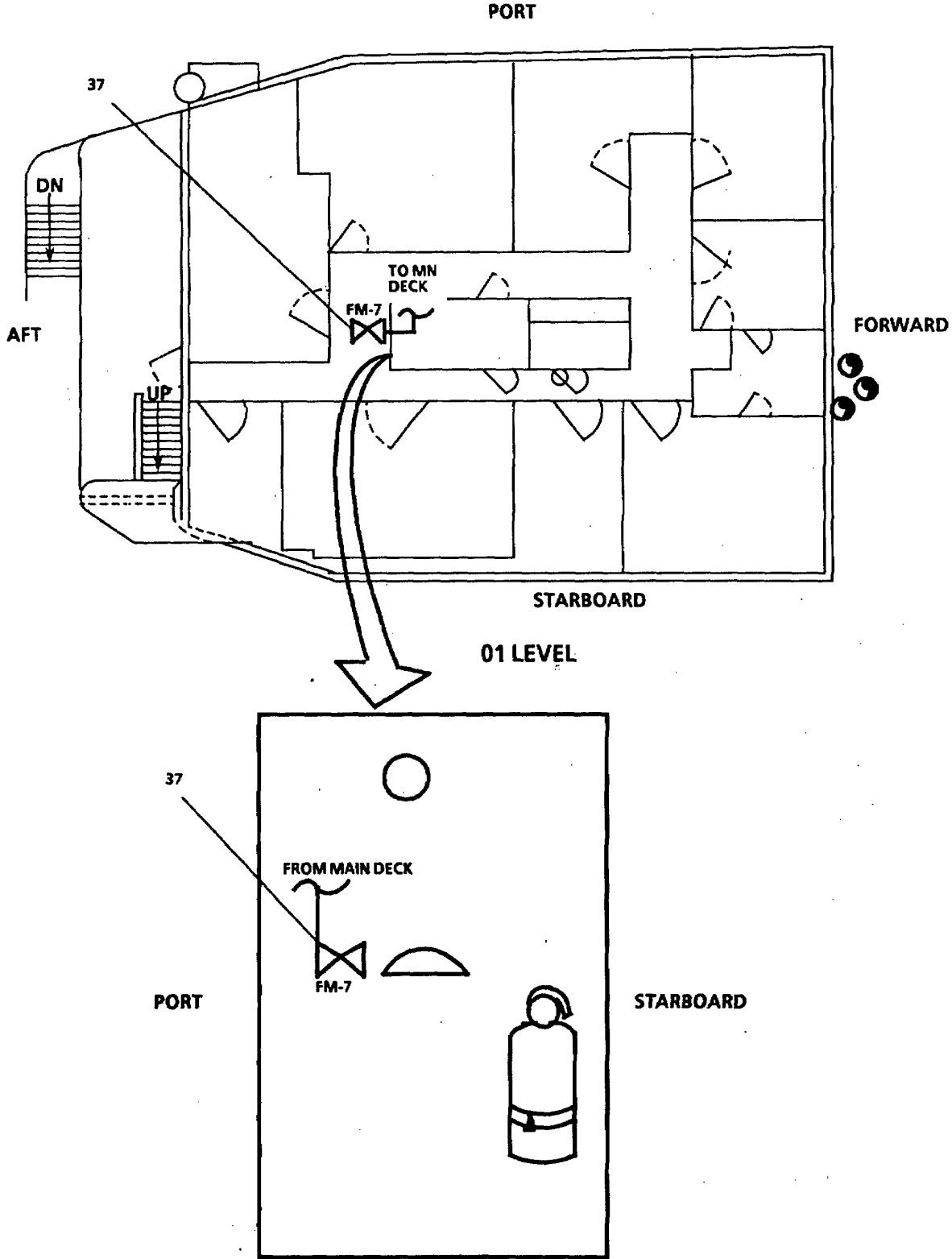

FIGURE 1-41. Fire Main and Foam Piping System (Sheet 9 of 12).

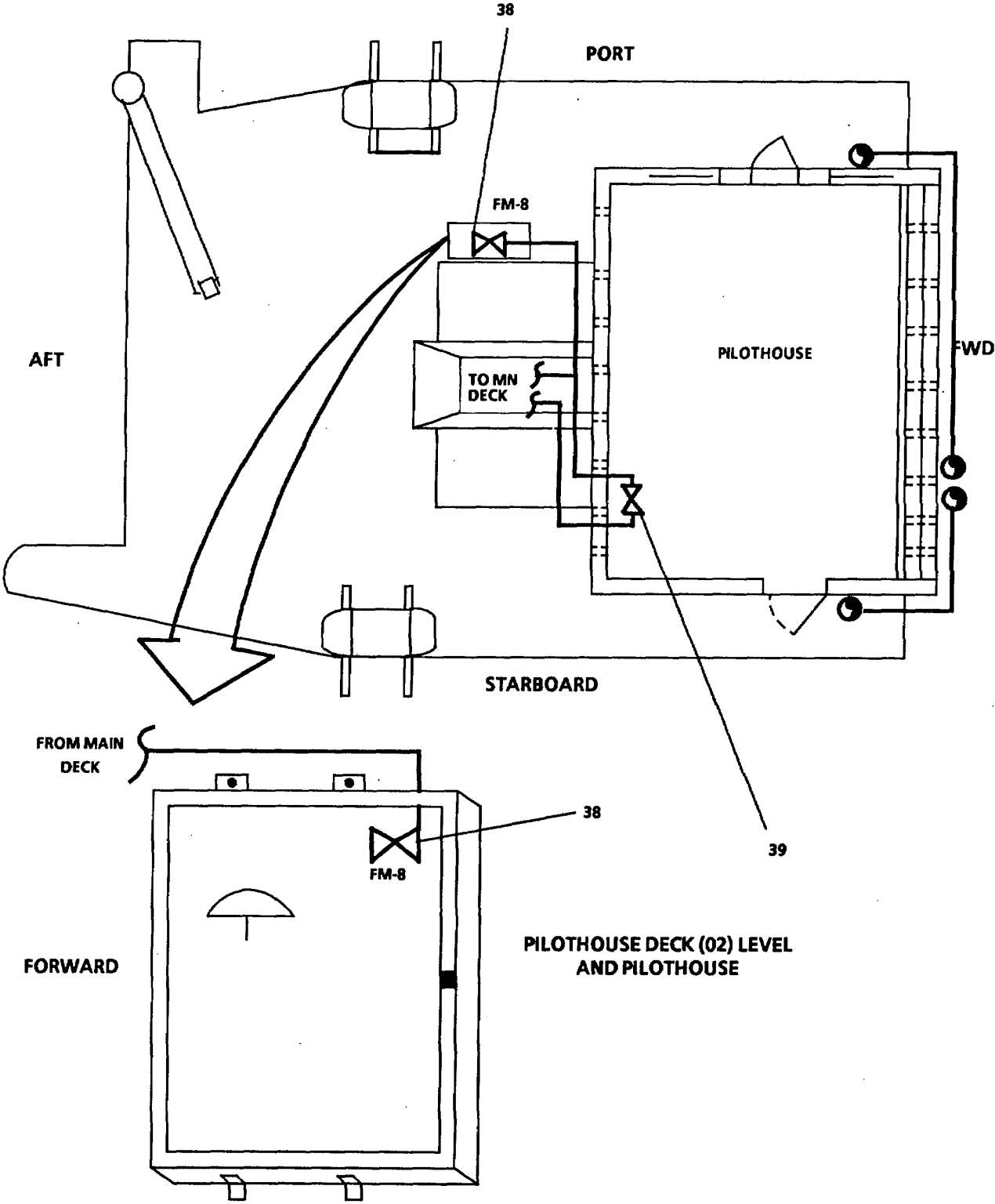

FIGURE 1-41. Fire Main and Foam Piping System (Sheet 10 of 12).



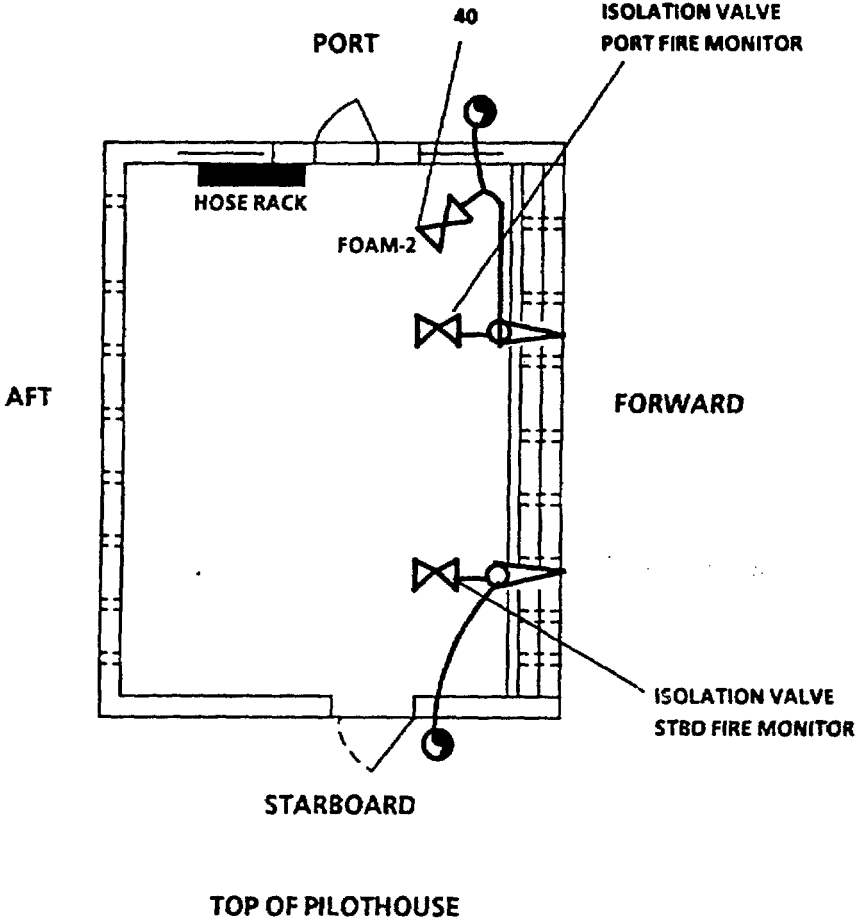

FIGURE 1-41. Fire Main and Foam Piping System (Sheet 11 of 12).

LEGEND

- |  |  |
|--|--|
| 1. FM-2, FIRE STA 2 ISLN                     | 21. FM-18, FIRE PUMP NO. 1 SUCT                        |
| 2. FW-29, SEA CHEST HOT FW CONN              | 22. FM-27, ENG RM EMERG BILGE SUCT                     |
| 3. BB-35, SEACHEST VENT ISOLATION            | 23. BB-25, ISLN-SEA CHEST                              |
| 4. FM-1, FIRE STA 1 ISLN                     | 24. BB-24, SUCT-BILGE/BALLAST PUMP                     |
| 5. BB-36, SEACHEST VENT                      | 25. BB-22, ISLN - SEA CHEST                            |
| 6. FM-10, FIREMAIN ISLN                      | 26. BB-23, SEA CHEST SUCT                              |
| 7. PRESSURE GAUGE ISOLATION                  | 27. BB-37, CROSS CONN TO BILGE MANIFOLD                |
| 8. FM-22, CM WASHDOWN ISLN                   | 28. BB-38, CROSS CONN FIRE PUMP SUCT TO BILGE MANIFOLD |
| 9. EDUCTOR                                   |  |
| 10. FOAM-1, FOAM STA 1 ISLN                  | 29. FM-13, FIREMAN & BALLAST CROSS CONN                |
| 11. FM-24, PORT FOAM MONITOR ISLN            | 30. FM-19, EMERG FIRE PUMP                             |
| 12. FM-23, STBD FOAM MONITOR ISLN            | 31. FM-20, EMERG FIRE PUMP DISCH                       |
| 13. FM-12, FOAM STA 1 & STBD MONITOR ISLN    | 32. FM-21, EMERG BILGE SUCT                            |
| 14. FM-11, FOAM STA 2 & PORT MONITOR ISLN    | 33. FM-9, FIRE STA 9 ISLN                              |
| 15. FM-15, NO. 2 FIRE PUMP DISCH             | 34. FM-3, FIRE STA 3 ISLN                              |
| 16. FM-14, NO. 1 FIRE PUMP DISCH             | 35. FM-4, FIRE STA 4 ISLN                              |
| 17. FM-16, FIRE PUMP 1 & 2 SUCT CROSS CONN   | 36. FM-6, FIRE STA 6 ISLN                              |
| 18. FM-17, FIRE PUMP NO.2 SUCT               | 37. FM-7, FIRE STA 7 ISLN                              |
| 19. FM-26, NO.2 FIRE PUMP STRAINER ISOLATION | 38. FM-8, FIRE STA 8 ISLN                              |
| 20. FM-25, NO.1 FIRE PUMP STRAINER ISOLATION | 39. ARMS ROOM SPRINKLER MANUAL ACTIVATION VALVE        |
| 40. FOAM-2, FOAM STA 2 ISLN                  |  |

FIGURE 1-41. Fire Main and Foam Piping System (Sheet 12 of 12).

**1-33. Seawater Cooling Piping System** The seawater cooling piping system (FIGURE 1-42) provides seawater for cooling and air conditioning units AC-1, AC-2, and AC-3. Seawater is also provided to the port and starboard stern tubes for lubrication, cooling, and flushing and to the marine sanitation device. System control is maintained through a combination of valves as shown in FIGURE 1-42. The system consists of the auxiliary seawater cooling pump and a duplex strainer in the piping B drawing seawater from the sea chest. The seawater regulating valves located in the emergency generator room provide a constant air conditioner condenser cooling water pressure. The seawater cooling pump receives power through the auxiliary machinery motor control center with a RUN indicator lamp on the EOS.

**1-34. Main Engine Fresh Water Cooling Piping System** The main engine fresh water cooling piping system extracts heat from the main engines by pumping fresh water through the engines. System control is maintained through a combination of valves as shown in FIGURE 1-43. The main engine fresh water cooling piping system receives fresh water from the potable water piping system. Fresh water is drawn from the expansion tanks into the engine cooling system by engine water pumps, pumped through the engine, and discharged through an external cooling system. The external cooling system cools the discharged fresh water by circulating the water through external grid (keel) coolers. The keel coolers are located outside the ship's hull.

**1-35. Ship's Service Diesel Generator (SSDG) Fresh Water Cooling Piping System** The SSDG fresh water cooling piping system extracts heat from the SSDG by pumping fresh water through the generators. System control is maintained through a combination of valves as shown in FIGURE 1-44. The SSDG fresh water cooling piping system receives fresh water from the potable water piping system. Fresh water is drawn into the engine cooling system by engine water pumps, pumped through the engine, and discharged through an external grid (keel) cooling system. The keel coolers are located under the ship's hull. During beaching conditions, when the external keel coolers may be out of the water, coolers located in seawater ballast tanks (SW-8P and SW-8S) may be selected with valve alignment, for continued SSDG fresh water cooling.

**1-36. Reduction Gear Lubricating Oil Fresh Water Cooling Piping System** The reduction gear lubricating oil fresh water cooling piping system cools the reduction gear lubricating oil by fresh water circulated through external keel coolers. Fresh water is supplied to the reduction gear lubricating oil fresh water cooling piping system by the potable water piping system. Fresh water circulation, under pressure, is provided by reduction gear cooling water pumps No. 1 (starboard) and No. 2 (port). Power for each pump is supplied through circuit breakers on the auxiliary machinery motor control center with pushbutton START and STOP controls adjacent to each pump. A pump running indicator lamp is located on the engine room operating station console. System control for both reduction gears is maintained through a combination of valves as shown in FIGURE 1-45.

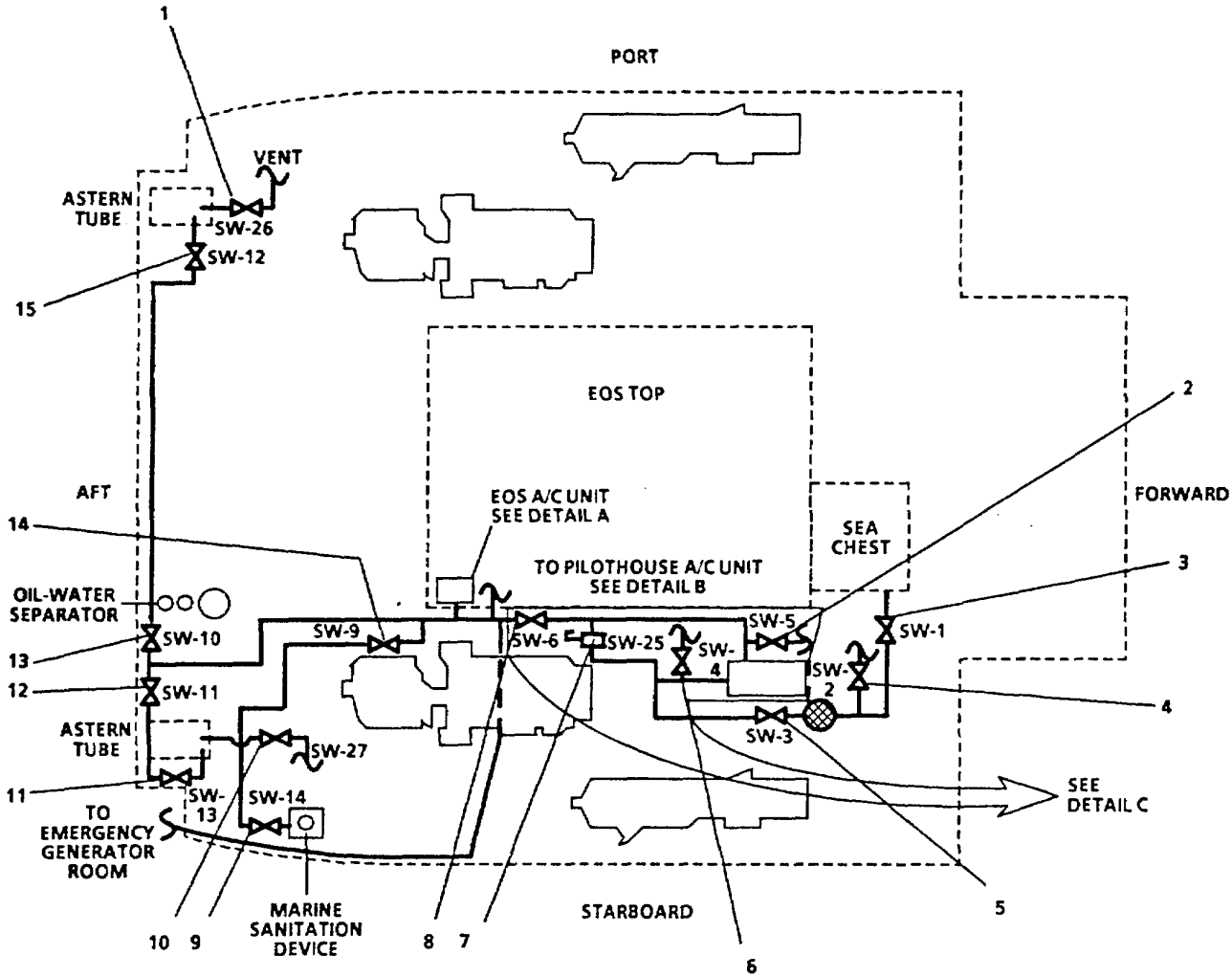
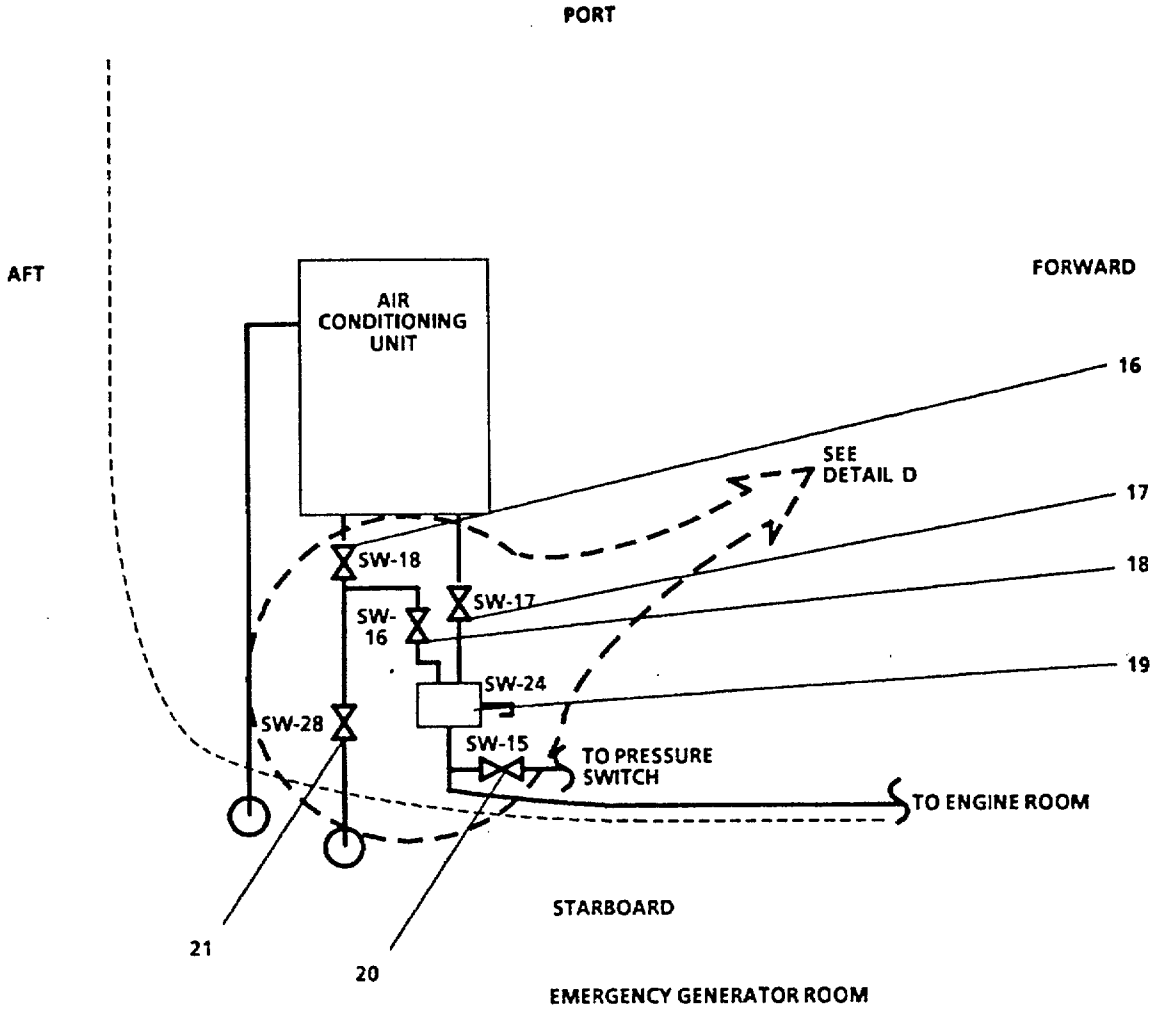
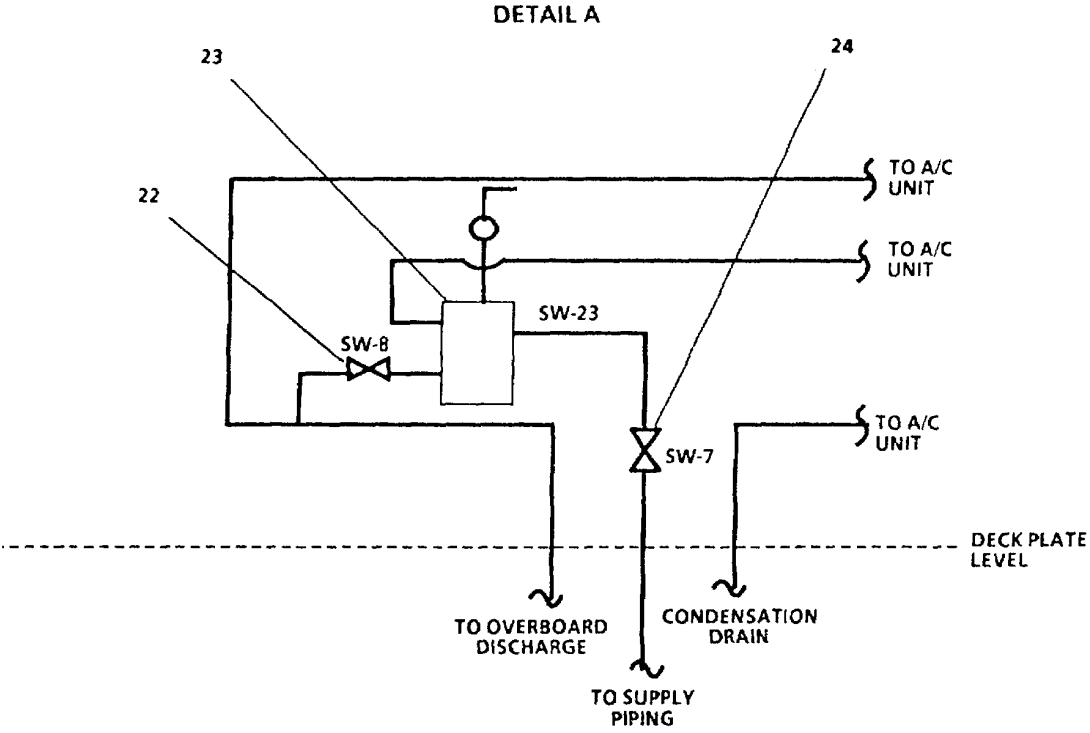

FIGURE 1-42. Sea Water Cooling Piping System (Sheet 1 of 6).



**NOTE:** SW-28 IS CONTROLLED FROM THE MAIN DECK STBD IN DECK ONLY. SW-28 IS PHYSICALLY LOCATED IN TANK SW-85

FIGURE 1-42. Sea Water Cooling Piping System (Sheet 2 of 6).



**EOS A/C UNIT  
(LOCATED IN EOS NEAR AIR HANDLING UNIT)**

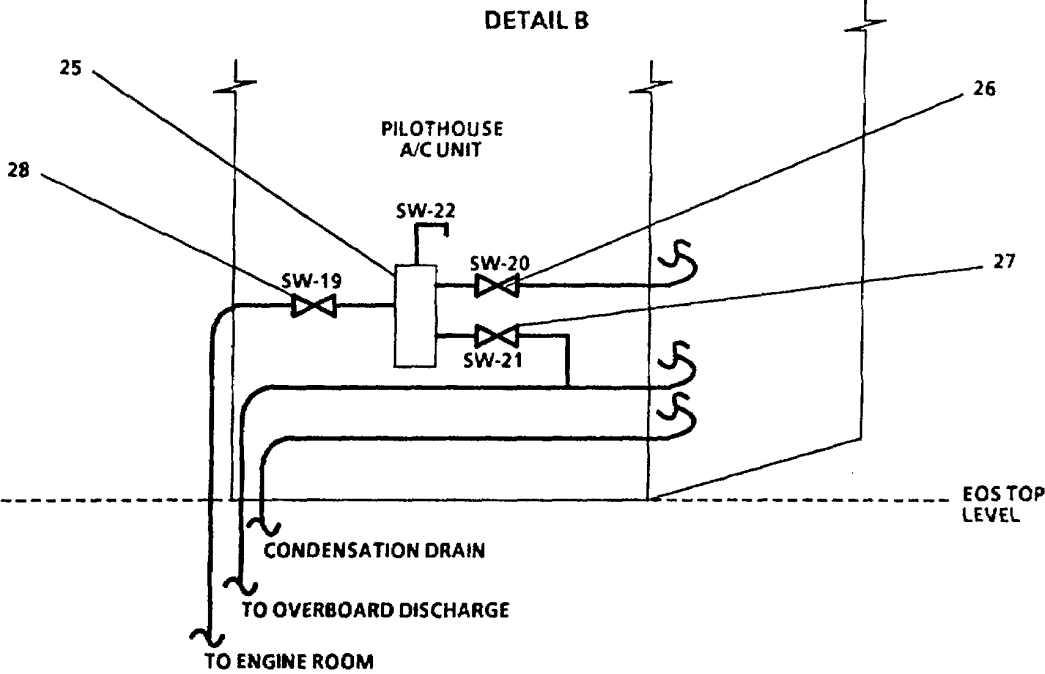

**PILOTHOUSE A/C UNIT**

FIGURE 1-42. Sea Water Cooling Piping System (Sheet 3 of 6).

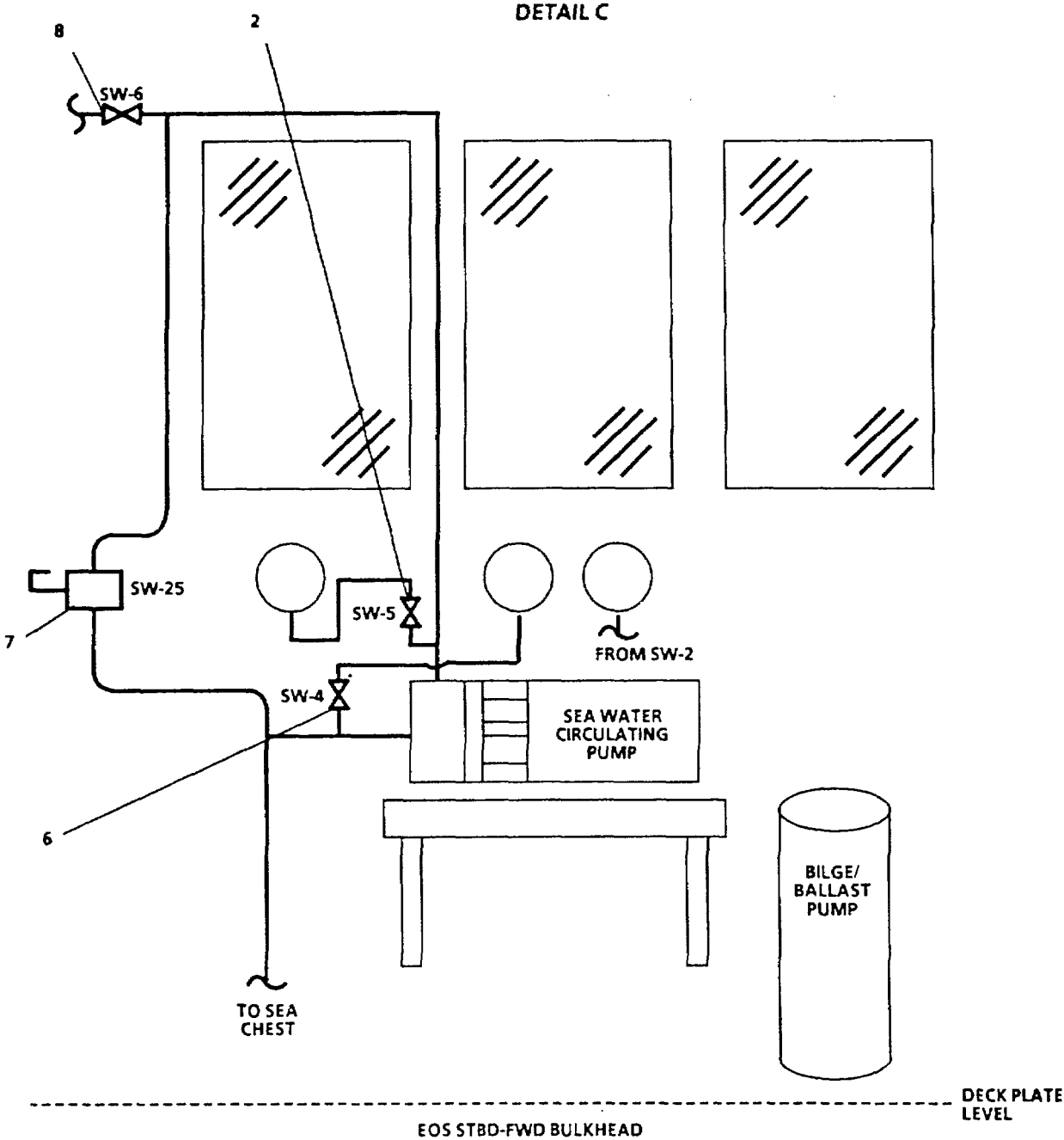

FIGURE 1-42. Sea Water Cooling Piping System (Sheet 4 of 6).

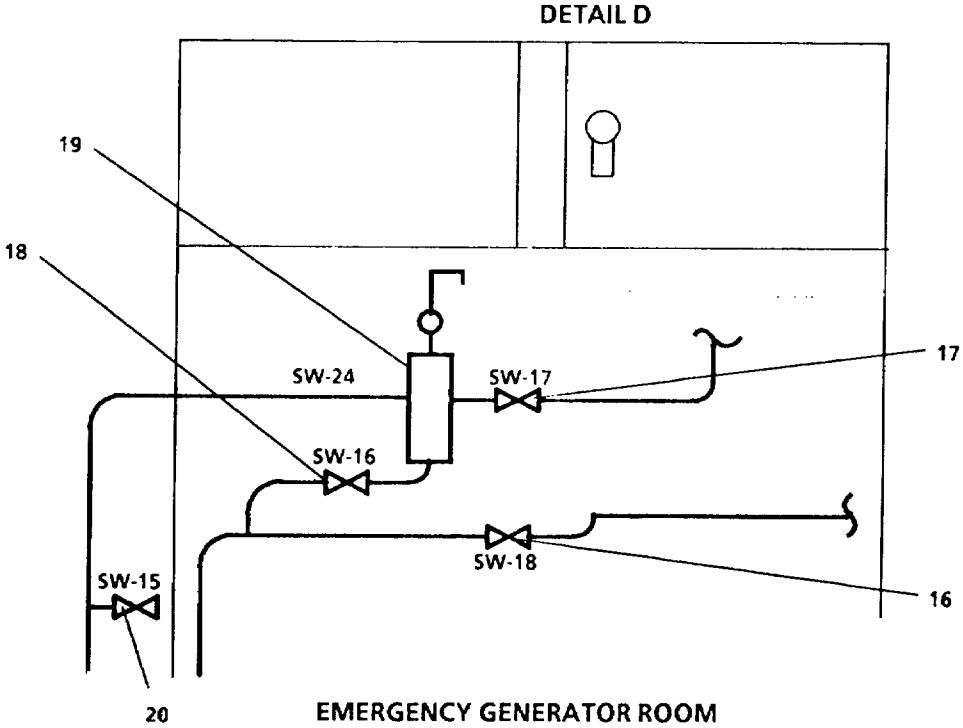

FIGURE 1-42. Sea Water Cooling Piping System (Sheet 5 of 6).



LEGEND

- |  |  |
|--|--|
| 1. SW-26, VENT-PORT STERN TUBE         | 15. SW-12, ISLN-PORT STERN TUBE        |
| 2. SW-5, PRESS GAGE PUMP DISCH         | 16. SW-18, DISCH FORM AIR COND UNIT    |
| 3. SW-1, SUPPLY TO PUMP                | 17. SW-17, SUPPLY TO AIR COND UNIT     |
| 4. SW-2, PRESS GAGE SUPPLY TO STRAINER | 18. SW-16, BY-PASS                     |
| 5. SW-3, PUMP SUCTION                  | 19. SW-24, REGULATING VALVE            |
| 6. SW-4, PRESS GAGE PUMP SUCTION       | 20. SW-15, SUPPLY TO PRESS SWITCH      |
| 7. SW-25, RELIEF VALVE SET AT 55 PSI   | 21. SW-28, OVBD DISCH FR AIR COND UNIT |
| 8. SW-6, PUMP DISCH                    | 22. SW-8, BY-PASS                      |
| 9. SW-14, ISOLATION-MSD                | 23. SW-23, REGULATING VALVE            |
| 10. SW-27, VENT-STBD STERNITUBE        | 24. SW-7, SUPPLY TO AIR COND UNIT      |
| 11. SW-13, ISLN-STBD STERN TUBE        | 25. SW-22, REGULATING VALVE            |
| 12. SW-11, SUPPLY TO STBD STERN TUBE   | 26. SW-20, ISLN TO AIR COND UNIT       |
| 13. SW-10, SUPPLY TO PORT STERN TUBE   | 27. SW-21, BY-PASS                     |
| 14. SW-9, SUPPLY TO MSD                | 28. SW-19, SUPPLY TO AIR COND UNIT     |

*FIGURE 1-42. Sea Water Cooling Piping System (Sheet 6 of 6).*

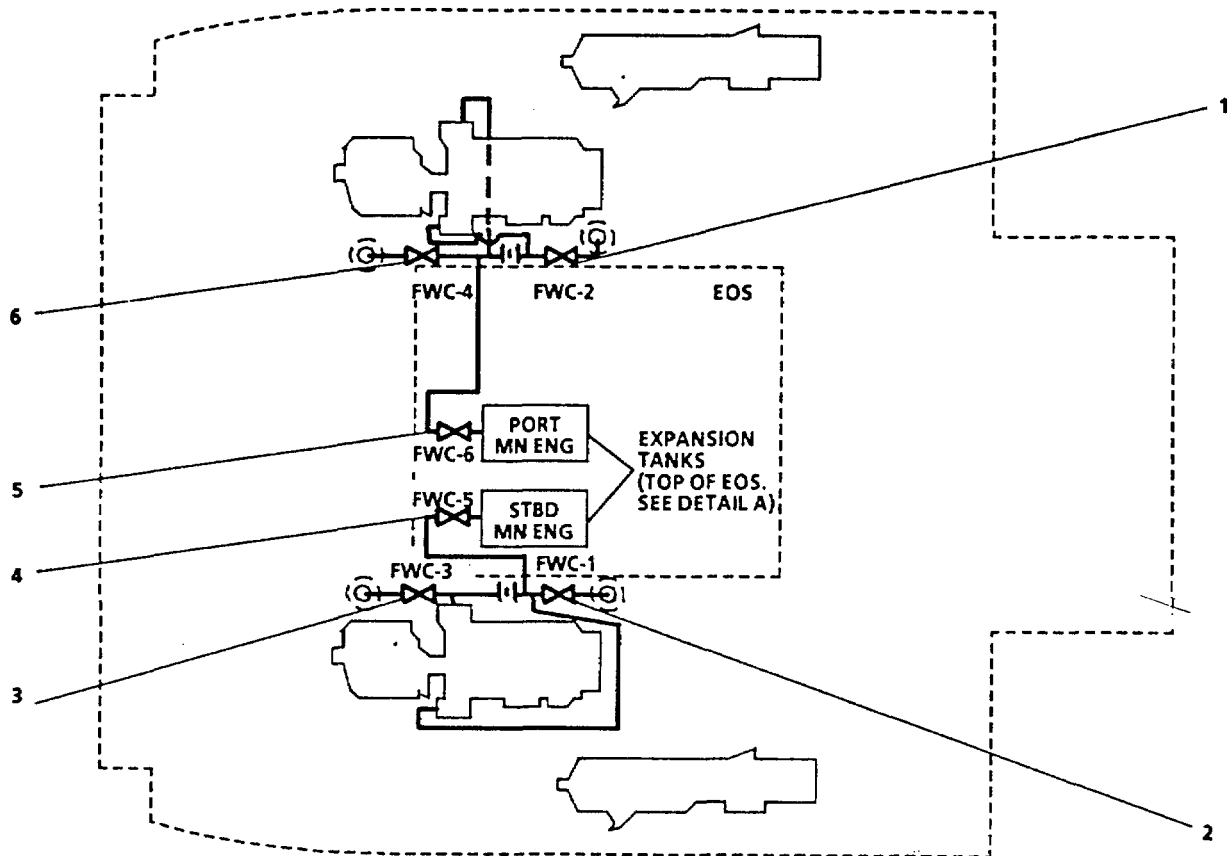

**LEGEND**

- |                              |                              |
|------------------------------|------------------------------|
| 1. FWC-2, SUPPLY-MN ENG PORT | 4. FWC-5, EXP TK-MN ENG STBD |
| 2. FWC-1, SUPPLY-MN ENG STBD | 5. FWC-6, EXP TK-MN ENG PORT |
| 3. FWC-3, RETURN-MN ENG STBD | 6. FWC-4, RETURN-MN ENG PORT |

FIGURE 1-43. Main Engines Fresh Water Cooling Piping System (Sheet 1 of 2).

DETAIL A

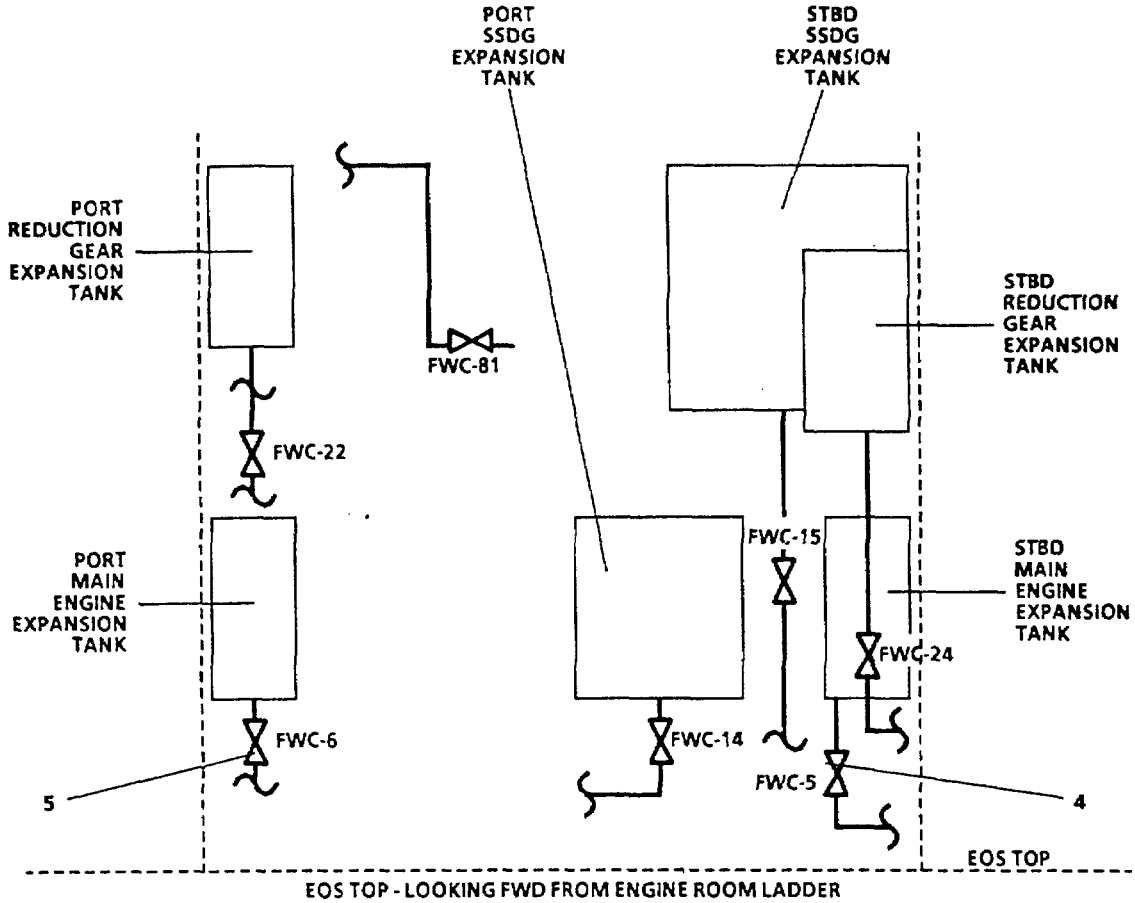

LEGEND

- 4. FWC-5, EXP TK-MN ENG STBD
- 5. FWC-6, EXP TK-MN ENG PORT

FIGURE 1-43. Main Engines Fresh Water Cooling Piping System (Sheet 2 of 2).

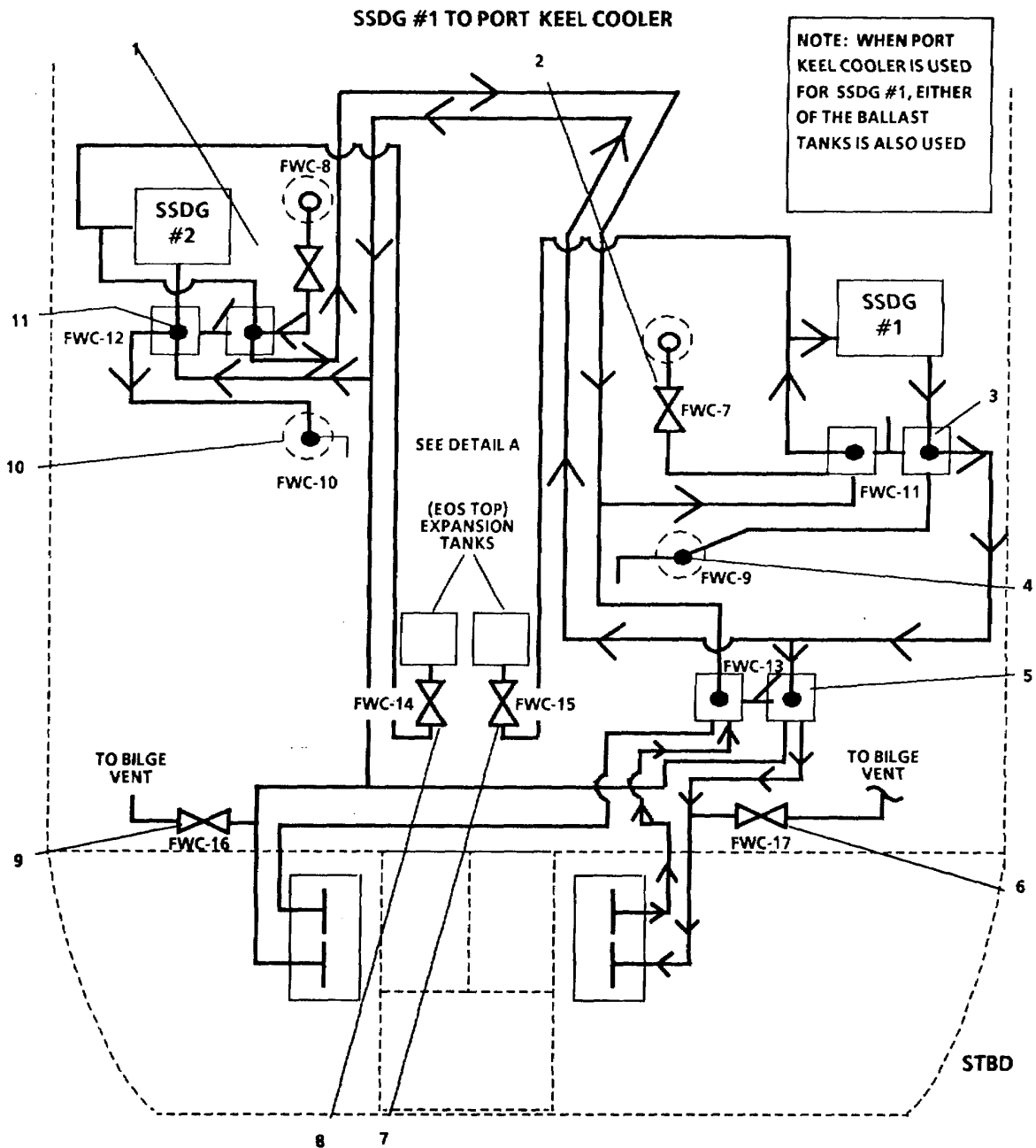

**LEGEND**

- |   |  |
|---|--|
| 1. FWC-8, KEEL CLR OUTLET                           | 7. FWC-15, EXP TK-SSDG STBD                      |
| 2. FWC-7, KEEL CLR OUTLET                           | 8. FWC-14, EXP TK-SSDG PORT                      |
| 3. FWS-11, KEEL CLR/SSDG-STBD CLG MODE              | 9. FWC-16, VENT KEEL CLR IN SWP-8P               |
| 4. FWC-9, KEEL CLR INLET                            | 10. FWC-10, KEEL CLR INLET                       |
| 5. FWC-13, KEEL CLR SELECTOR BLST TK SW-8P OR SW-8S | 11. FWC-12, KEEL CLR/SSDG-PORT CLG MODE SELECTOR |
| 6. FWC-17, VENT KEEL CLR IN SW-8S                   |  |

FIGURE 1-44. Ship's Service Diesel Generator Fresh Water Cooling Piping System (Sheet 1 of 9).

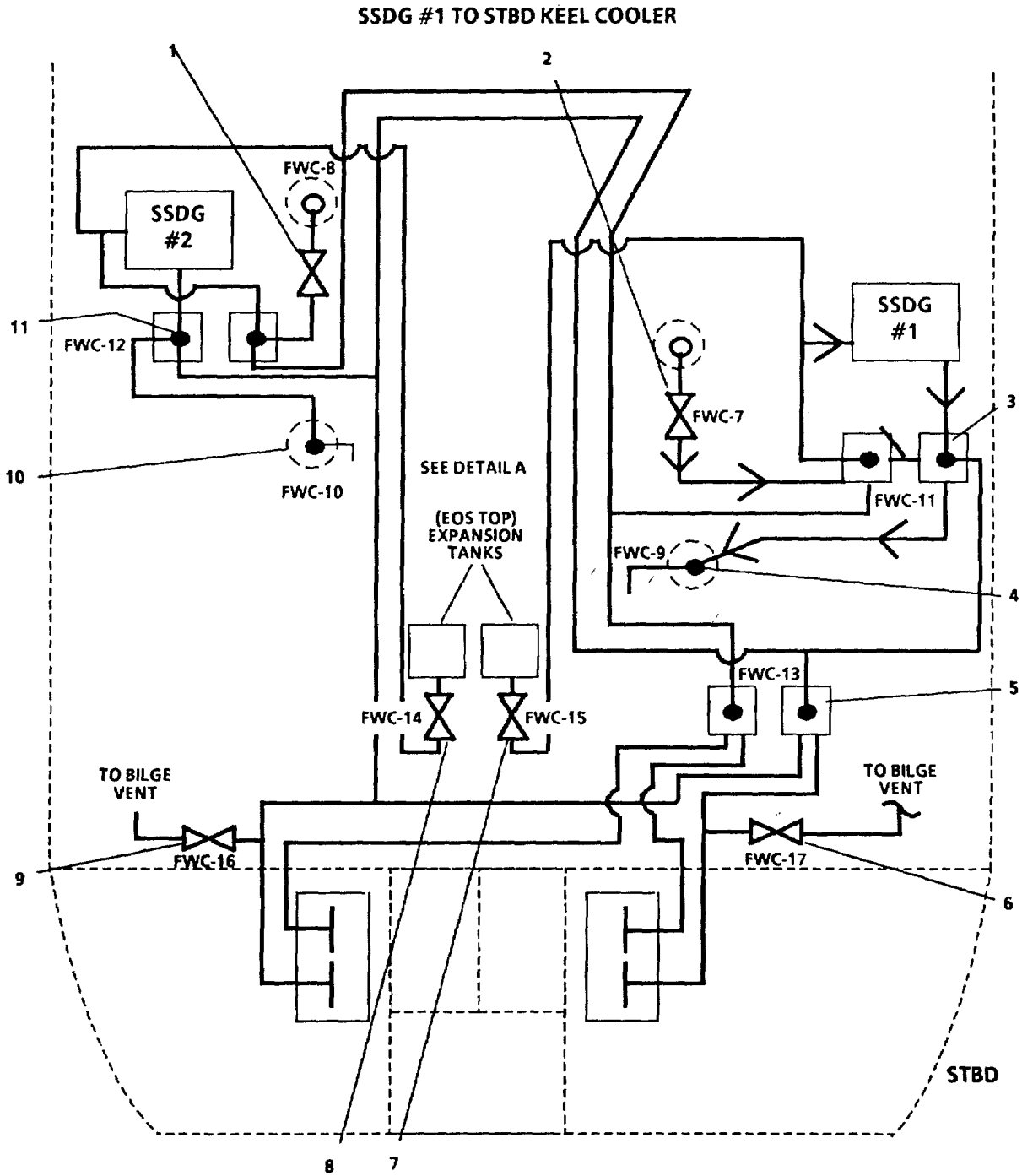

**LEGEND**

- |   |  |
|---|--|
| 1. FWC-8, KEEL CLR OUTLET                           | 7. FWC-15, EXP TK-SSDG STBD                      |
| 2. FWC-7, KEEL CLR OUTLET                           | 8. FWC-14, EXP TK-SSDG PORT                      |
| 3. FWS-11, KEEL CLR/SSDG-STBD CLG MODE              | 9. FWC-16, VENT KEEL CLR IN SWP-8P               |
| 4. FWC-9, KEEL CLR INLET                            | 10. FWC-10, KEEL CLR INLET                       |
| 5. FWC-13, KEEL CLR SELECTOR BLST TK SW-8P OR SW-8S | 11. FWC-12, KEEL CLR/SSDG-PORT CLG MODE SELECTOR |
| 6. FWC-17, VENT KEEL CLR IN SW-8S                   |  |

FIGURE 1-44. Ship's Service Diesel Generator Fresh Water Cooling Piping System (Sheet 2 of 9).

SSDG #1 TO PORT BALLAST TK COOLER

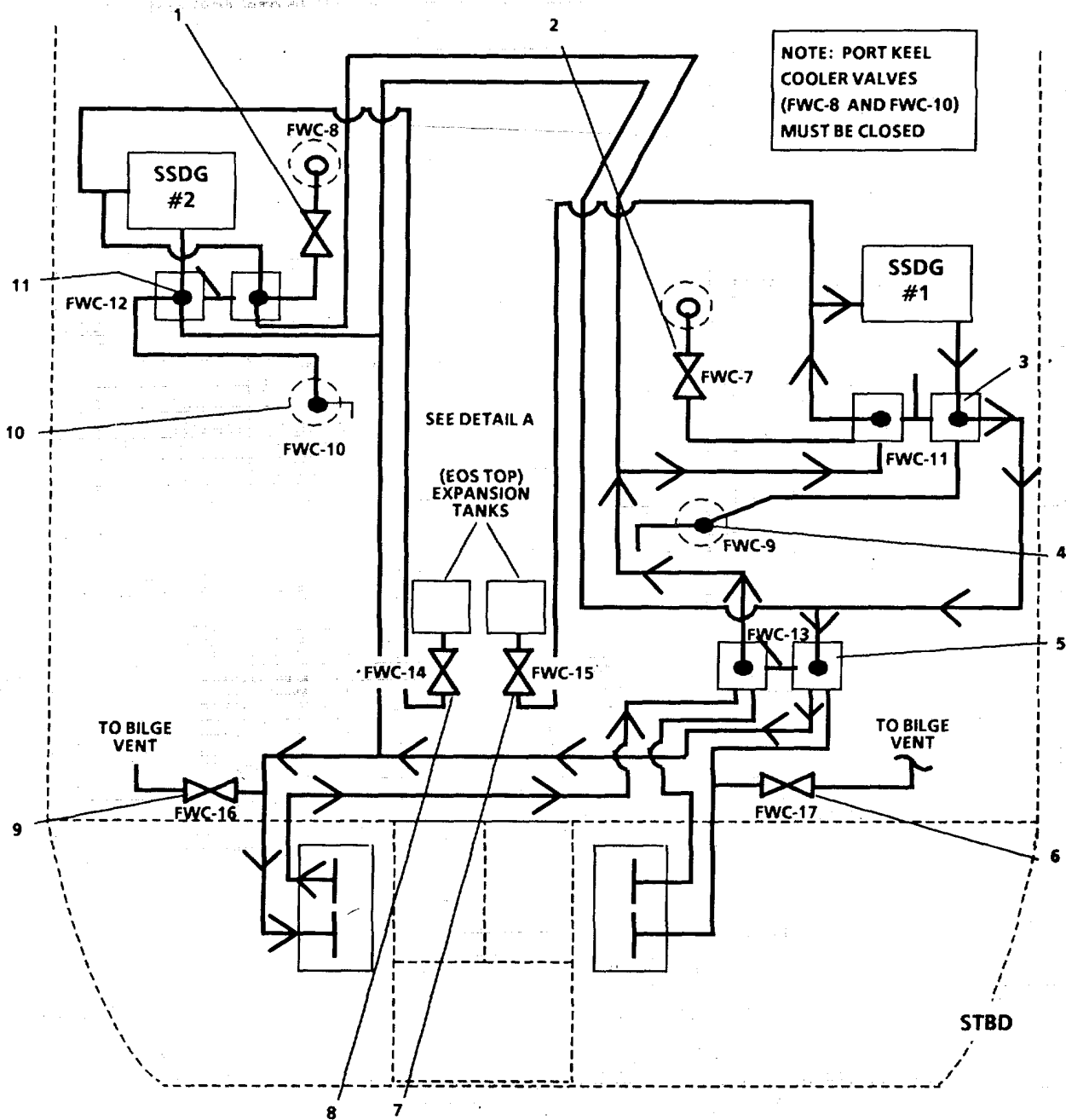

LEGEND

- |  |  |
|--|--|
| 1. FWC-8, KEEL CLR OUTLET                            | 7. FWC-15, EXP TK-SSDG STBD                      |
| 2. FWC-7, KEEL CLR OUTLET                            | 8. FWC-14, EXP TK-SSDG PORT                      |
| 3. FWS-11, KEEL CLR/SSDG-STBD CLG MODE               | 9. FWC-16, VENT KEEL CLR IN SWP-8P               |
| 4. FWC-9, KEEL CLR INLET                             | 10. FWC-10, KEEL CLR INLET                       |
| 5. FWC-13, KEEL CLR SELECTOR BLST TK SW-8P OR SW -8S | 11. FWC-12, KEEL CLR/SSDG-PORT CLG MODE SELECTOR |
| 6. FWC-17, VENT KEEL CLR IN SW-8S                    |  |

FIGURE 1-44. Ship's Service Diesel Generator Fresh Water Cooling Piping System (Sheet 3 of 9).

SSDG #1 TO STBD BALLAST TK COOLER

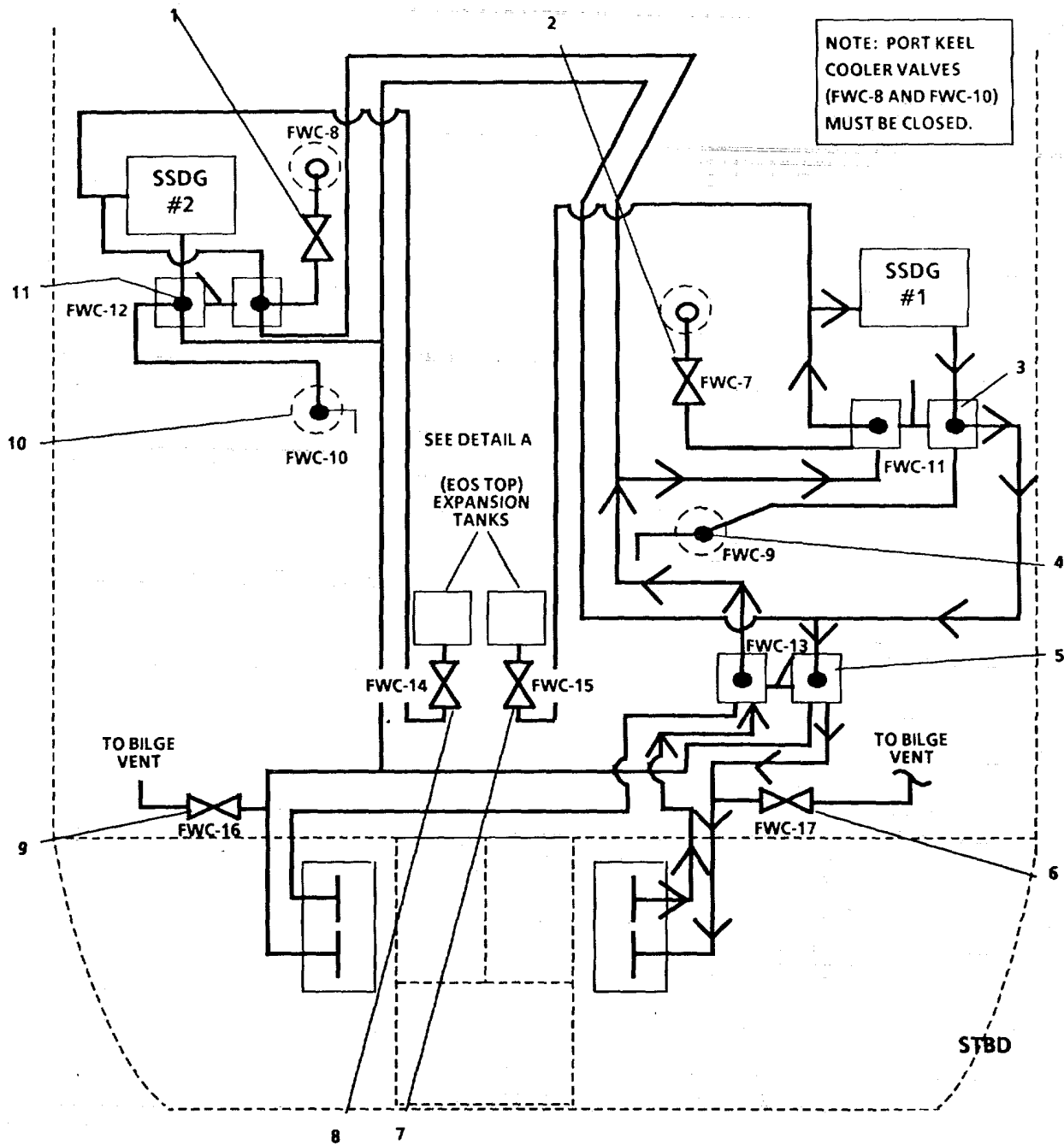

LEGEND

- |   |  |
|---|--|
| 1. FWC-8, KEEL CLR OUTLET                           | 7. FWC-15, EXP TK-SSDG STBD                      |
| 2. FWC-7, KEEL CLR OUTLET                           | 8. FWC-14, EXP TK-SSDG PORT                      |
| 3. FWS-11, KEEL CLR/SSDG-STBD CLG MODE              | 9. FWC-16, VENT KEEL CLR IN SWP-8P               |
| 4. FWC-9, KEEL CLR INLET                            | 10. FWC-10, KEEL CLR INLET                       |
| 5. FWC-13, KEEL CLR SELECTOR BLST TK SW-8P OR SW-8S | 11. FWC-12, KEEL CLR/SSDG-PORT CLG MODE SELECTOR |
| 6. FWC-17, VENT KEEL CLR IN SW-8S                   |  |

FIGURE 1-44. Ship's Service Diesel Generator Fresh Water Cooling Piping System (Sheet 4 of 9).

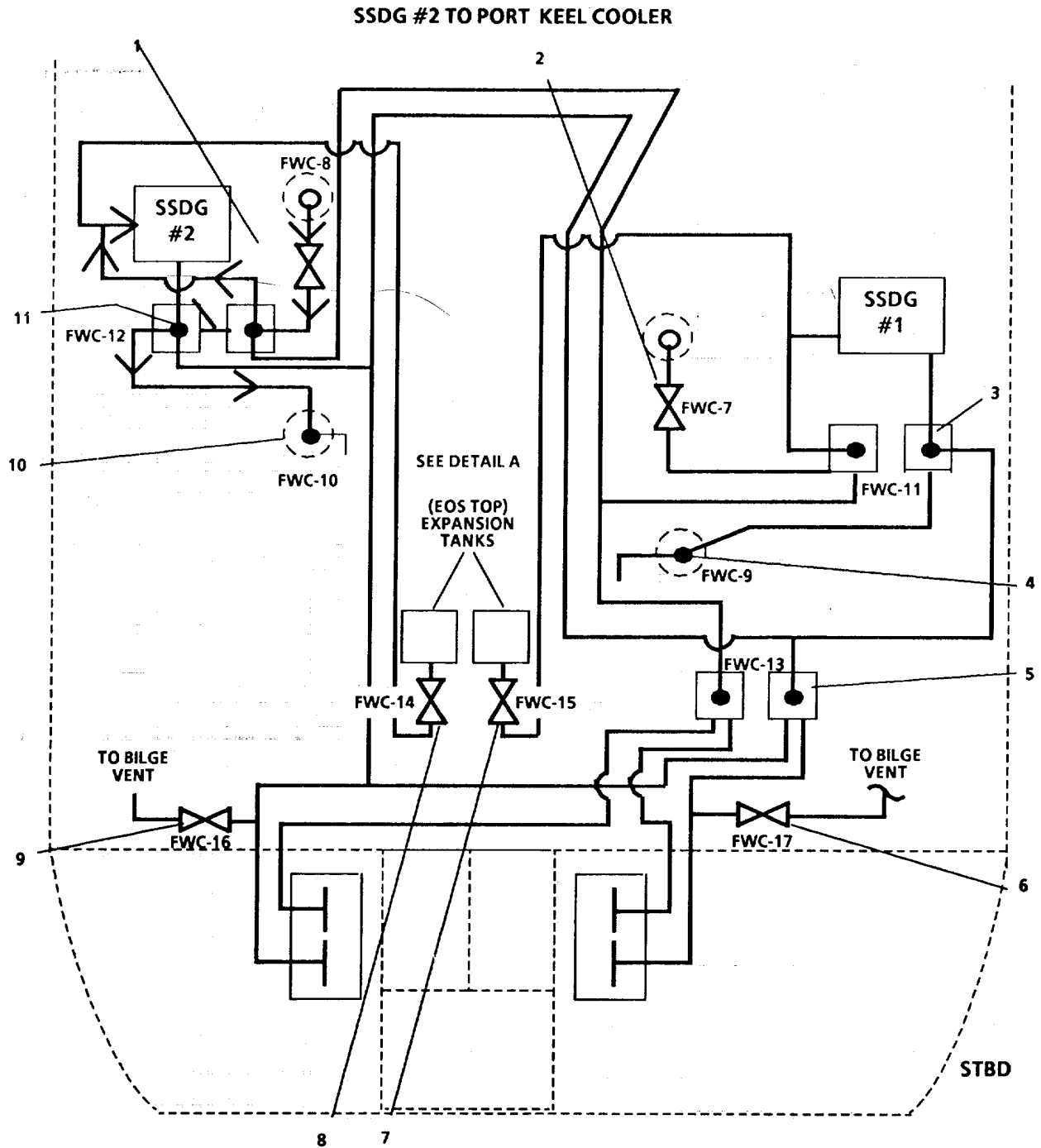

**LEGEND**

- |   |  |
|---|--|
| 1. FWC-8, KEEL CLR OUTLET                           | 7. FWC-15, EXP TK-SSDG STBD                      |
| 2. FWC-7, KEEL CLR OUTLET                           | 8. FWC-14, EXP TK-SSDG PORT                      |
| 3. FWS-11, KEEL CLR/SSDG-STBD CLG MODE              | 9. FWC-16, VENT KEEL CLR IN SWP-8P               |
| 4. FWC-9, KEEL CLR INLET                            | 10. FWC-10, KEEL CLR INLET                       |
| 5. FWC-13, KEEL CLR SELECTOR BLST TK SW-8P OR SW-8S | 11. FWC-12, KEEL CLR/SSDG-PORT CLG MODE SELECTOR |
| 6. FWC-17, VENT KEEL CLR IN SW-8S                   |  |

FIGURE 1-44. Ship's Service Diesel Generator Fresh Water Cooling Piping System (Sheet 5 of 9).



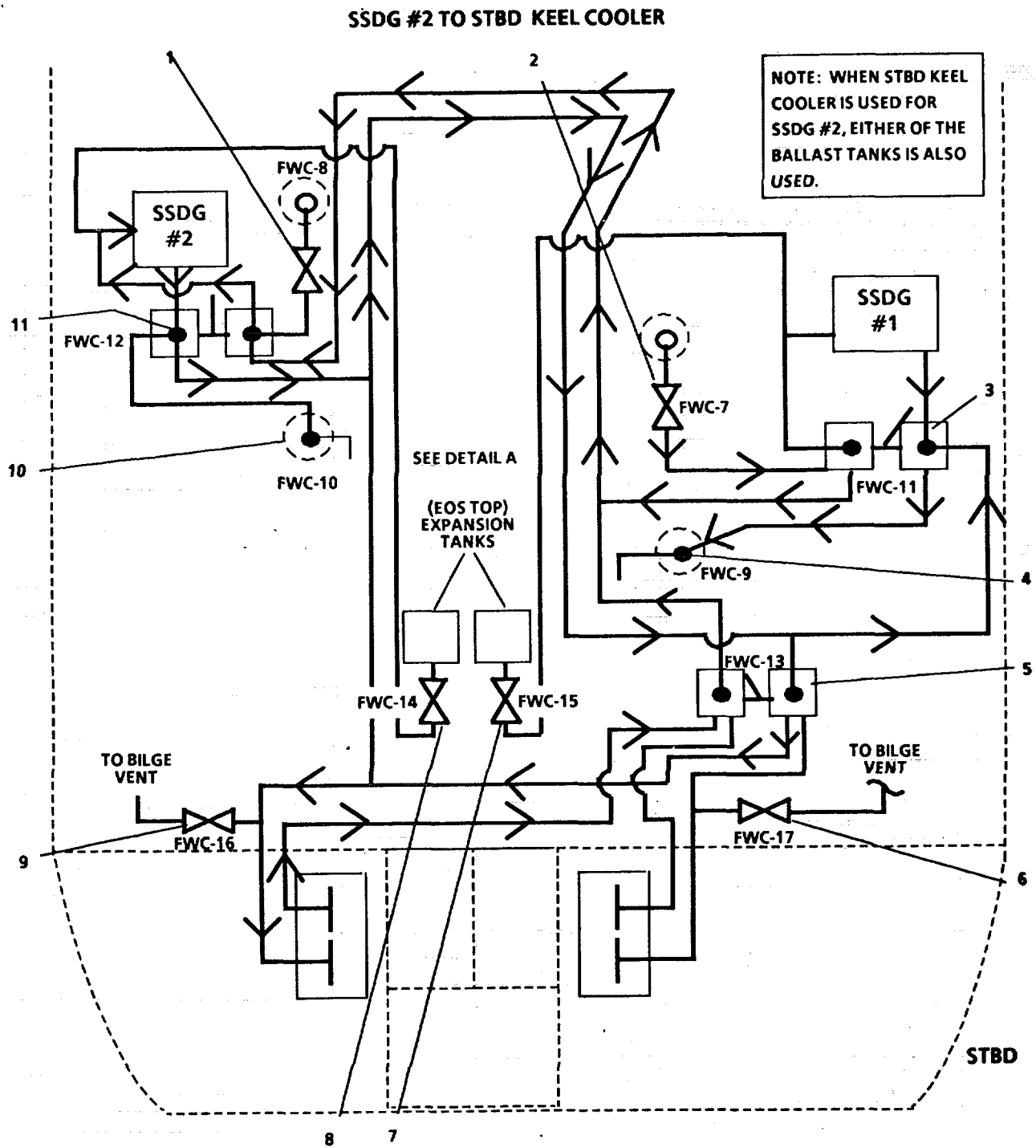

**LEGEND**

- |   |   |
|---|---|
| <p>1. FWC-8, KEEL CLR OUTLET</p> <p>2. FWC-7, KEEL CLR OUTLET</p> <p>3. FWS-11, KEEL CLR/SSDG-STBD CLG MODE</p> <p>4. FWC-9, KEEL CLR INLET</p> <p>5. FWC-13, KEEL CLR SELECTOR BLST TK SW-8P OR SW-8S</p> <p>6. FWC-17, VENT KEEL CLR IN SW-8S</p> | <p>7. FWC-15, EXP TK-SSDG STBD</p> <p>8. FWC-14, EXP TK-SSDG PORT</p> <p>9. FWC-16, VENT KEEL CLR IN SWP-8P</p> <p>10. FWC-10, KEEL CLR INLET</p> <p>11. FWC-12, KEEL CLR/SSDG-PORT CLG MODE SELECTOR</p> |
|---|---|

FIGURE 1-44. Ship's Service Diesel Generator Fresh Water Cooling Piping System (Sheet 6 of 9).

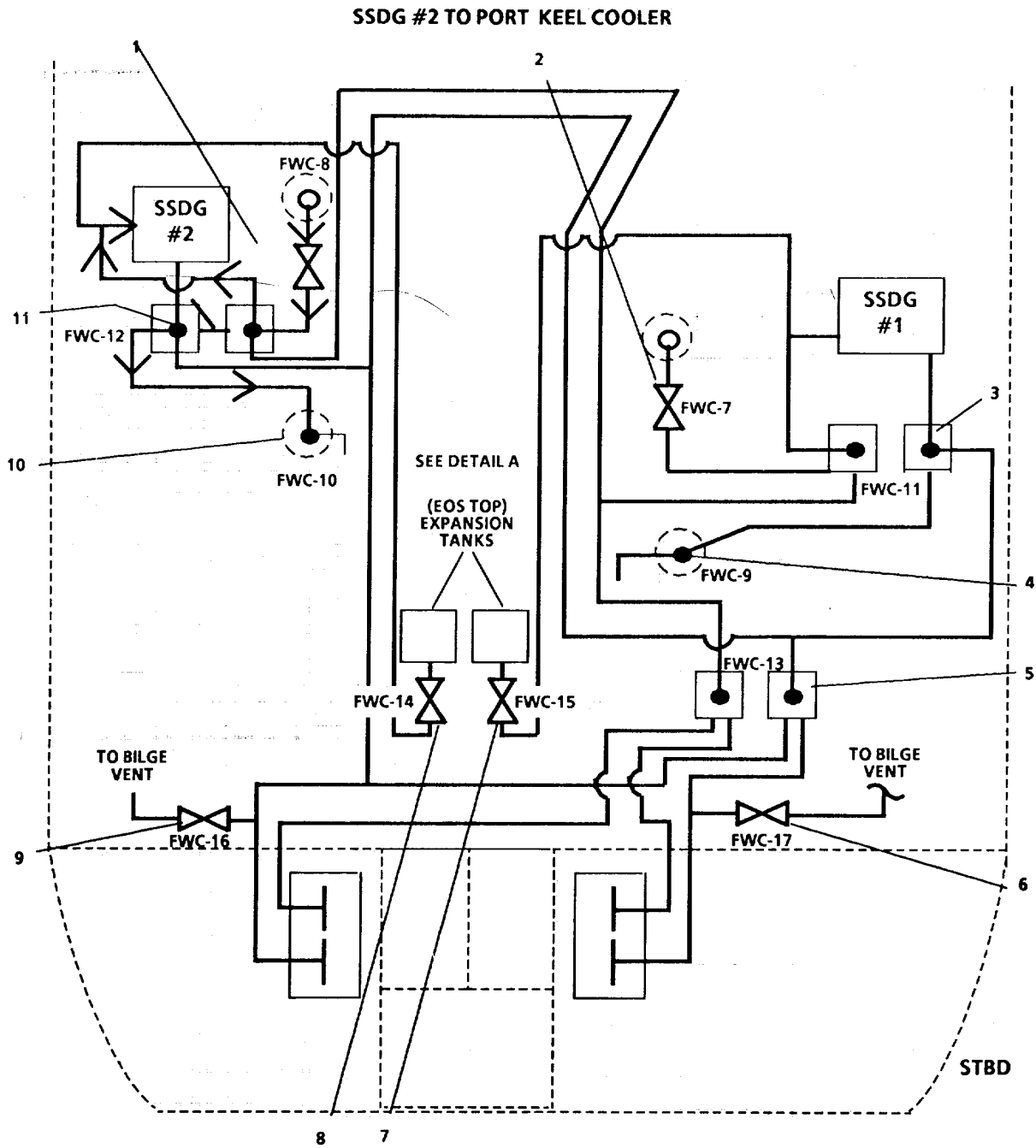

**LEGEND**

- |   |  |
|---|--|
| 1. FWC-8, KEEL CLR OUTLET                           | 7. FWC-15, EXP TK-SSDG STBD                      |
| 2. FWC-7, KEEL CLR OUTLET                           | 8. FWC-14, EXP TK-SSDG PORT                      |
| 3. FWS-11, KEEL CLR/SSDG-STBD CLG MODE              | 9. FWC-16, VENT KEEL CLR IN SWP-8P               |
| 4. FWC-9, KEEL CLR INLET                            | 10. FWC-10, KEEL CLR INLET                       |
| 5. FWC-13, KEEL CLR SELECTOR BLST TK SW-8P OR SW-8S | 11. FWC-12, KEEL CLR/SSDG-PORT CLG MODE SELECTOR |
| 6. FWC-17, VENT KEEL CLR IN SW-8S                   |  |

FIGURE 1-44. Ship's Service Diesel Generator Fresh Water Cooling Piping System (Sheet 7 of 9).

SSDG #2 TO STBD BALLAST TK COOLER

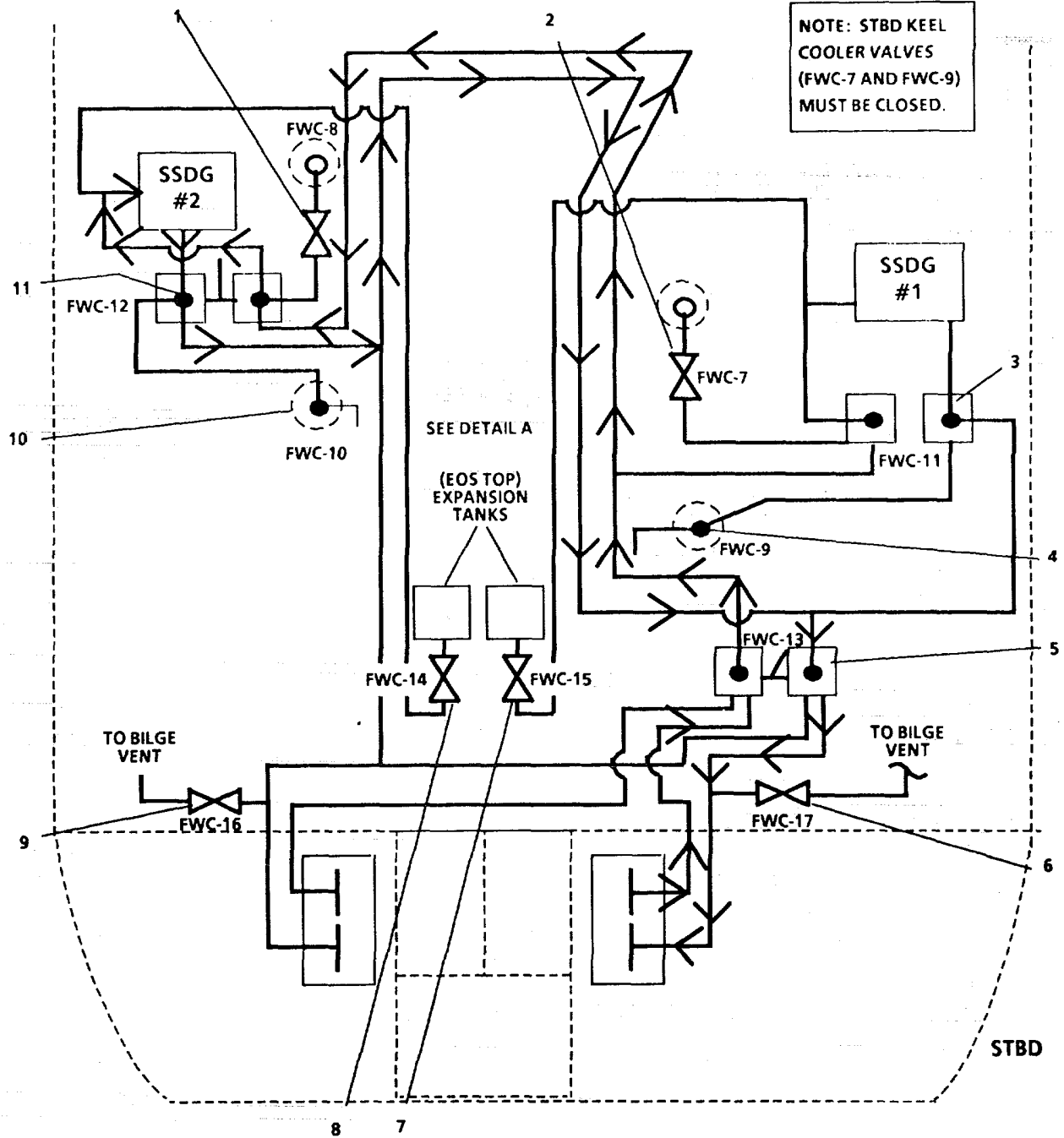

LEGEND

- |   |  |
|---|--|
| 1. FWC-8, KEEL CLR OUTLET                           | 7. FWC-15, EXP TK-SSDG STBD                      |
| 2. FWC-7, KEEL CLR OUTLET                           | 8. FWC-14, EXP TK-SSDG PORT                      |
| 3. FWS-11, KEEL CLR/SSDG-STBD CLG MODE              | 9. FWC-16, VENT KEEL CLR IN SWP-8P               |
| 4. FWC-9, KEEL CLR INLET                            | 10. FWC-10, KEEL CLR INLET                       |
| 5. FWC-13, KEEL CLR SELECTOR BLST TK SW-8P OR SW-8S | 11. FWC-12, KEEL CLR/SSDG-PORT CLG MODE SELECTOR |
| 6. FWC-17, VENT KEEL CLR IN SW-8S                   |  |

FIGURE 1-44. Ship's Service Diesel Generator Fresh Water Cooling Piping System (Sheet 8 of 9).

DETAIL A

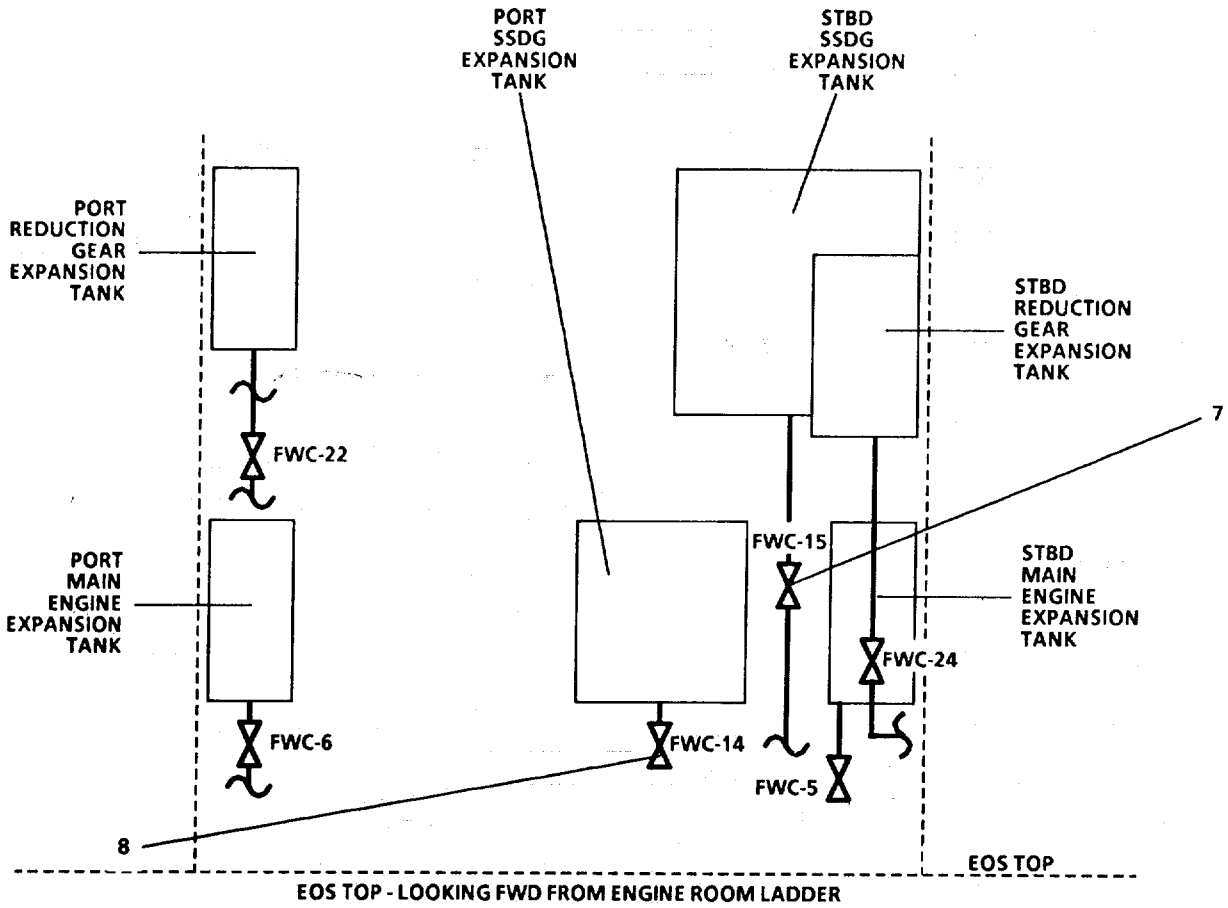

LEGEND:

- 7. FWC-15, EXP TK-SSDG STBD
- 9. FWC-14, EXP TK-SSDG PORT

FIGURE 1-44. Ship's Service Diesel Generator Fresh Water Cooling Piping System (Sheet 9 of 9).

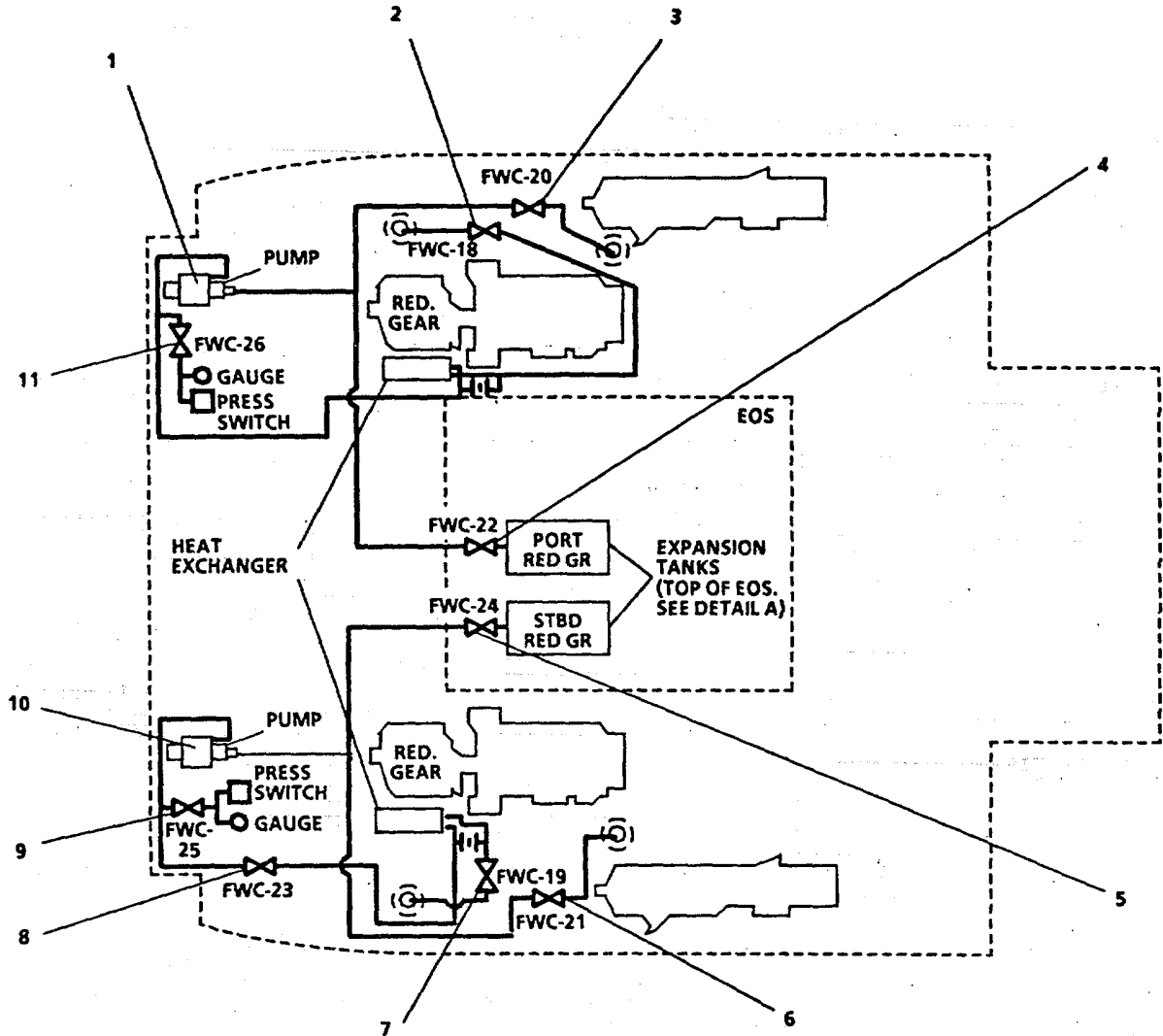

**LEGEND:**

- |  |  |
|--|--|
| 1. PORT RDCN GEAR COOLING PUMP               | 7. FWC-19, RETURN TO KEEL CLR RDCN GEAR STBD                         |
| 2. FWC-18, RETURN TO KEEL CLR RDCN GEAR PORT | 8. FWC-23, PUMP DISCH-RDCN GEAR STBD                                 |
| 3. FWC-20, PUMP SUCT-RDCN GEAR PORT          | 9. FWC-25, PRESS SW & PRESS GAGE PUMP DISCH-RDCN GEAR STBD           |
| 4. FWC-22, EXP TK-RDCN GEAR PORT             | 10. STBD RDCN GEAR COOLING PUMP                                      |
| 5. FWC-24, EXP TK-RDCN GEAR STBD             | 11. FWC-26, REDUCTION GEAR LUB OIL FRESH WATER COOLING PIPING SYSTEM |
| 6. FWC-21, PUMP SUCT-RDCN GEAR STBD          |  |

FIGURE 1-45. Reduction Gear Lube Oil Fresh Water Cooling Piping System (Sheet 1 of 2).

DETAIL A

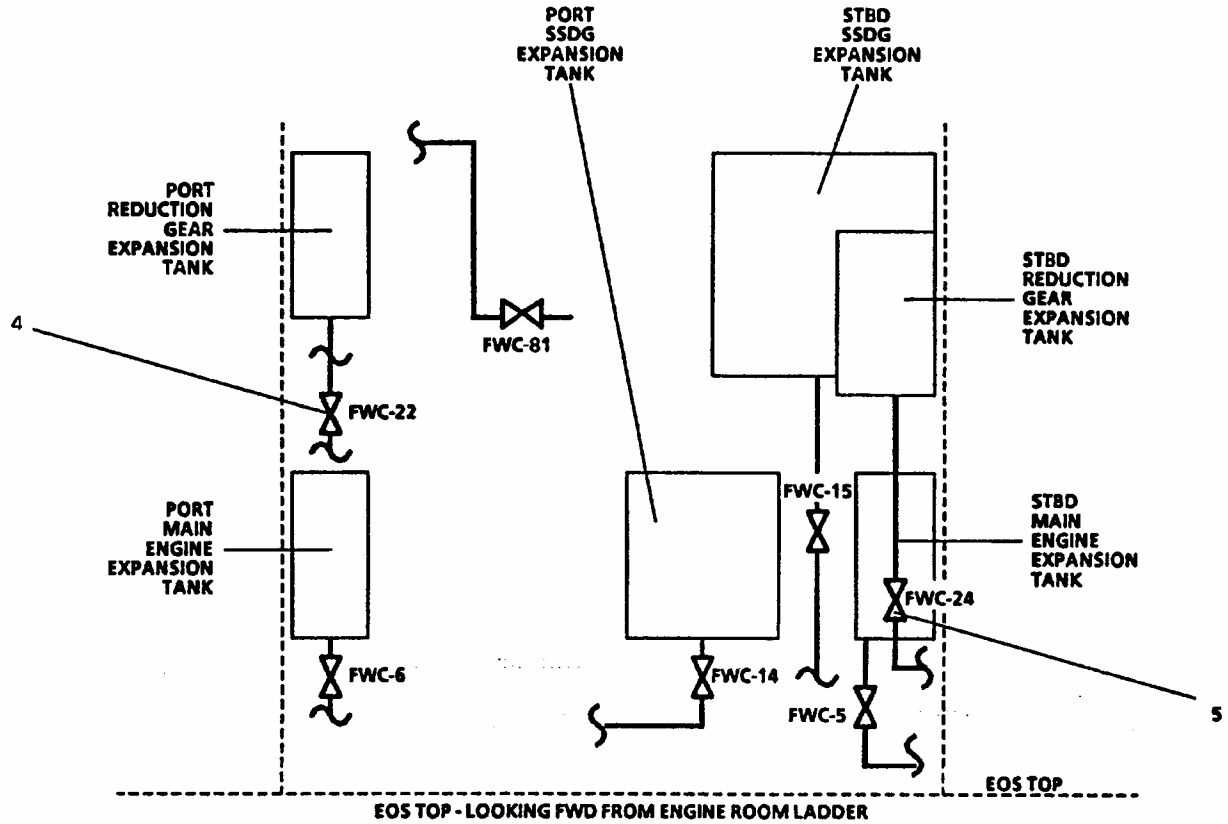

LEGEND:

- |  |  |
|--|--|
| 1. PORT RDCN GEAR COOLING PUMP               | 7. FWC-19, RETURN TO KEEL CLR RDCN GEAR STBD               |
| 2. FWC-18, RETURN TO KEEL CLR RDCN GEAR PORT | 8. FWC-23, PUMP DISCH-RDCN GEAR STBD                       |
| 3. FWC-20, PUMP SUCT-RDCN GEAR PORT          | 9. FWC-25, PRESS SW & PRESS GAGE PUMP DISCH-RDCN GEAR STBD |
| 4. FWC-22, EXP TK-RDCN GEAR PORT             | 10. STBD RDCN GEAR COOLING PUMP                            |
| 5. FWC-24, EXP TK-RDCN GEAR STBD             | 11. FWC-26   |
| 6. FWC-21, PUMP SUCT-RDCN GEAR STBD          |  |

FIGURE 1-45, Reduction Gear Lube Oil Fresh Water Cooling Piping System (Sheet 2 of 2).

**1-37. Hydraulic Oil Supply Piping System.** The hydraulic oil supply piping system (FIGURE 1-46) replenishes the hydraulic oil storage tank and supplies hydraulic oil to supply points in the following compartments; boatswain storeroom, bowthruster room and steering gear room. The supply points provide hydraulic oil for the following:

- a. Boatswain Storeroom. Bow ramp winch hydraulic power pack and starboard bow anchor windlass hydraulic power pack.
- b. Bowthruster Room. Port bow anchor windlass hydraulic power pack and bowthruster hydraulic power pack.
- c. Steering Gear Room. Port side: steering gear hydraulic power pack and starboard side, Stern side: anchor winch hydraulic power pack.

Supply points are replenished by pressurizing the supply line with the hand pump and filling containers at the supply points.

**1-38. Fuel Oil Transfer Piping System.** The fuel oil transfer piping system replenishes the ship's fuel oil tanks for deck discharge/fill connections and replenishes engine and generator day tanks by transferring fuel oil from storage tanks. System control is maintained through a combination of valves as shown in FIGURE 1-47. Fuel oil can be transferred between any storage tank and day tank. No. 1 fuel oil transfer pump is supplied power from the auxiliary machinery motor control center and controlled by a START/STOP pushbutton and an emergency STOP switch at the pump. No. 2 fuel oil transfer pump is supplied power from the emergency switchboard 240 Vac distribution and controlled by a START/STOP pushbutton and an emergency stop pushbutton. Each pump has a run indicator lamp on the engine room operating station console.

#### NOTE

**Not applicable to vessels with FM-200 Fire Suppressant System installed. Reference paragraph 2-46 through 2-47 for FM-200 and Water Washdown System operation. Reference TM 55-1905-243-24&P, LCU-2000, FM-200 Fire Fighting System for maintenance and installation of FM-200 components.**

Each pump also will be shut down upon any HALON pressure switch activation. Fuel oil purification is provided by the fuel oil filter/separator. Included in the fuel oil transfer piping system is dual fuel filters for each main engine. In an emergency, fuel may be transferred by the hand pump.

**1-39. Compressed Air Piping System.** The compressed air piping system delivers the air pressure required for starting the main engines, No. 2 SSDG (port), and other uses. System control is maintained through a combination of valves as shown in FIGURE 1-48. The compressed air piping system consists of two compressors that deliver compressed air to two 200 gallon air receivers at 200 pounds per square inch (psi) pressure. This air passes through a reducing valve, reducing the pressure to control air pressure of 125 psi, moisture separator and an automatic dryer to points of usage. Supply air is furnished to sea chest blow down. Service air is supplied to the machine shop, bowthruster room and above deck points. Control air is supplied to the dual throttle control system. Air pressure is controlled from individual compressor pressure switches. Compressor power is supplied by the auxiliary machinery motor control center with pushbutton START/STOP stations located at each compressor. Each compressor has a run indicator lamp on the engine room control console.

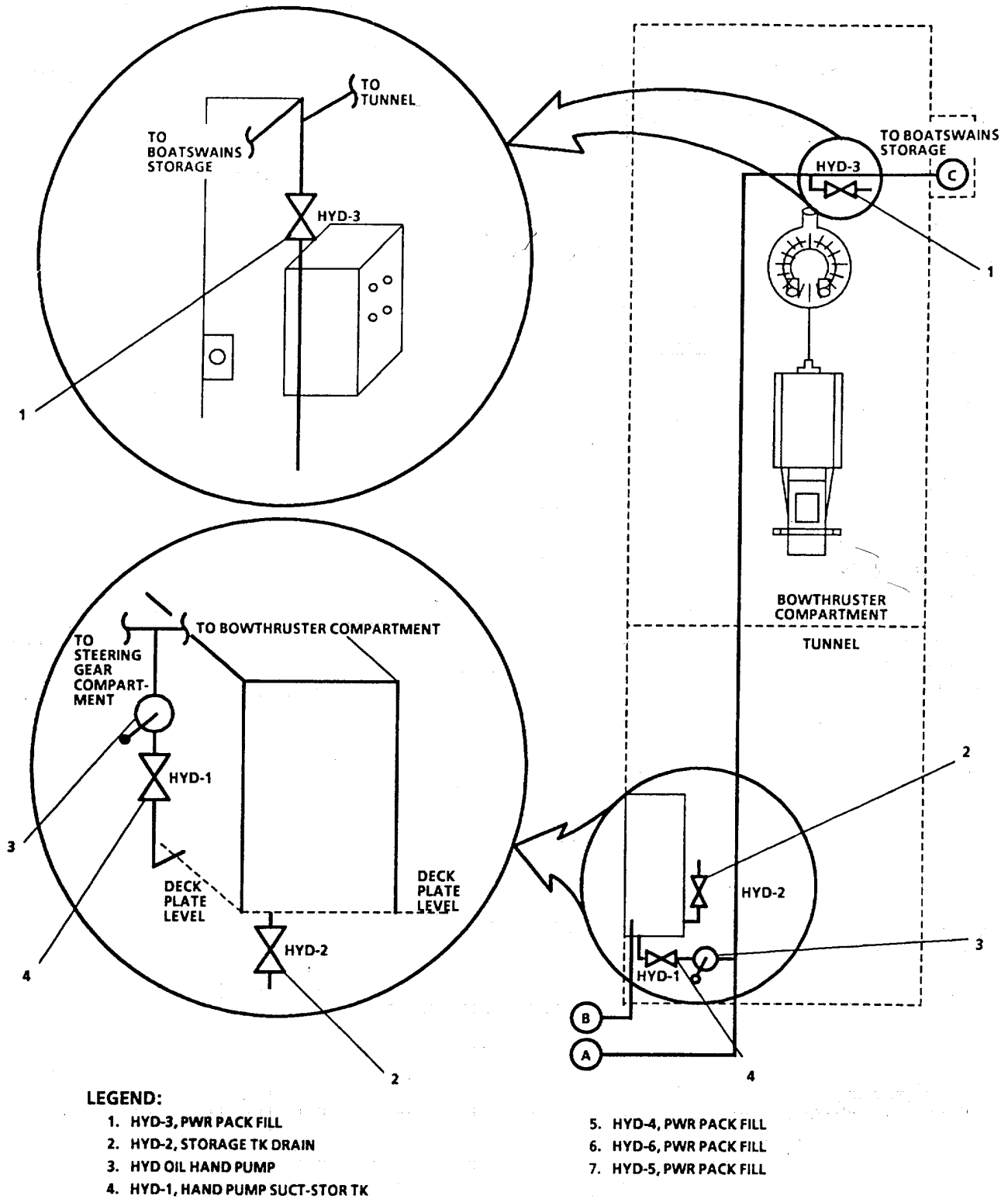
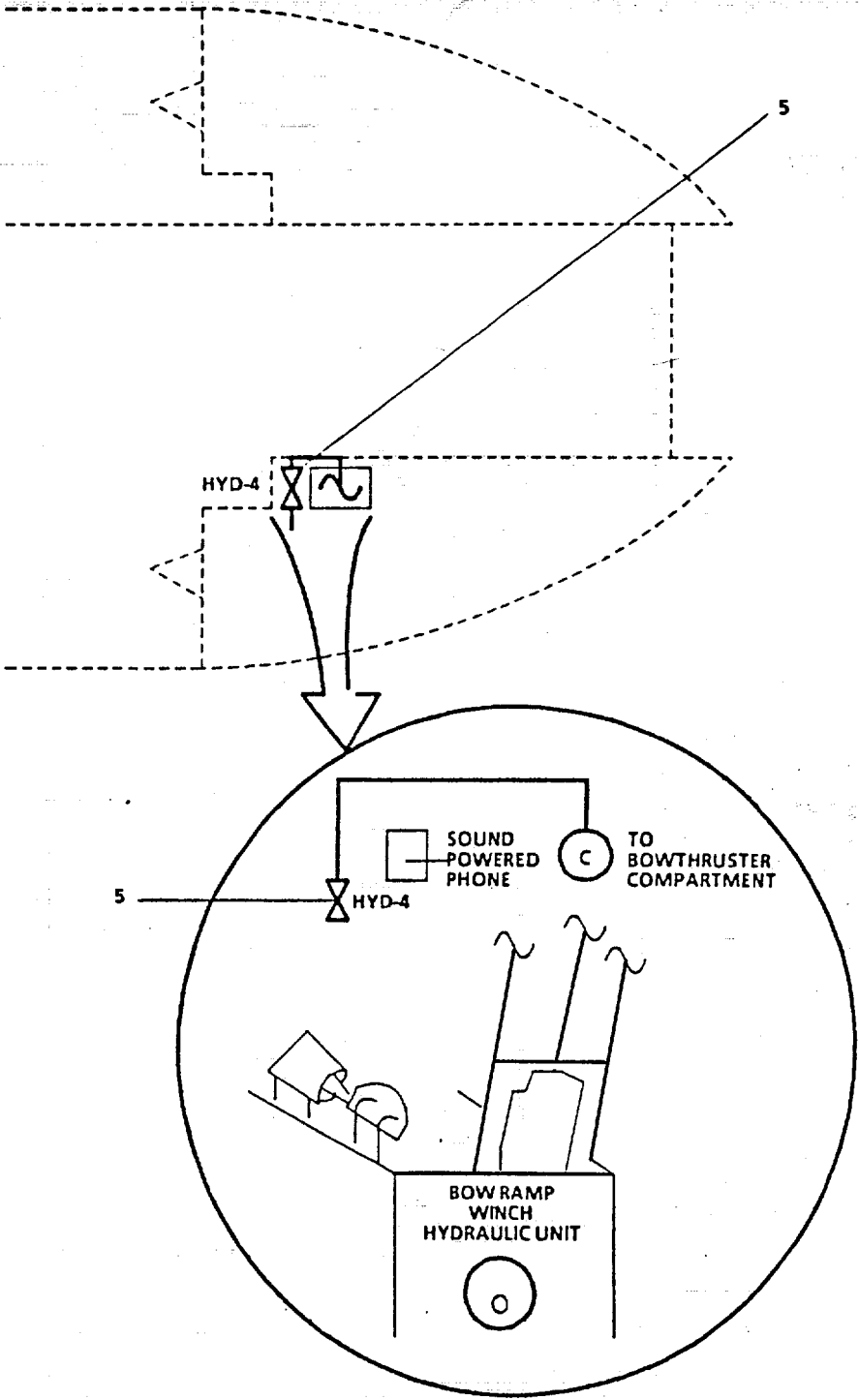

FIGURE 1-46. Hydraulic Oil Supply Piping System (Sheet 1 of 3).





**LEGEND:**

5. HYD-4, PWR PACK FILL

FIGURE 1-46. Hydraulic Oil Supply Piping System (Sheet 2 of 3).

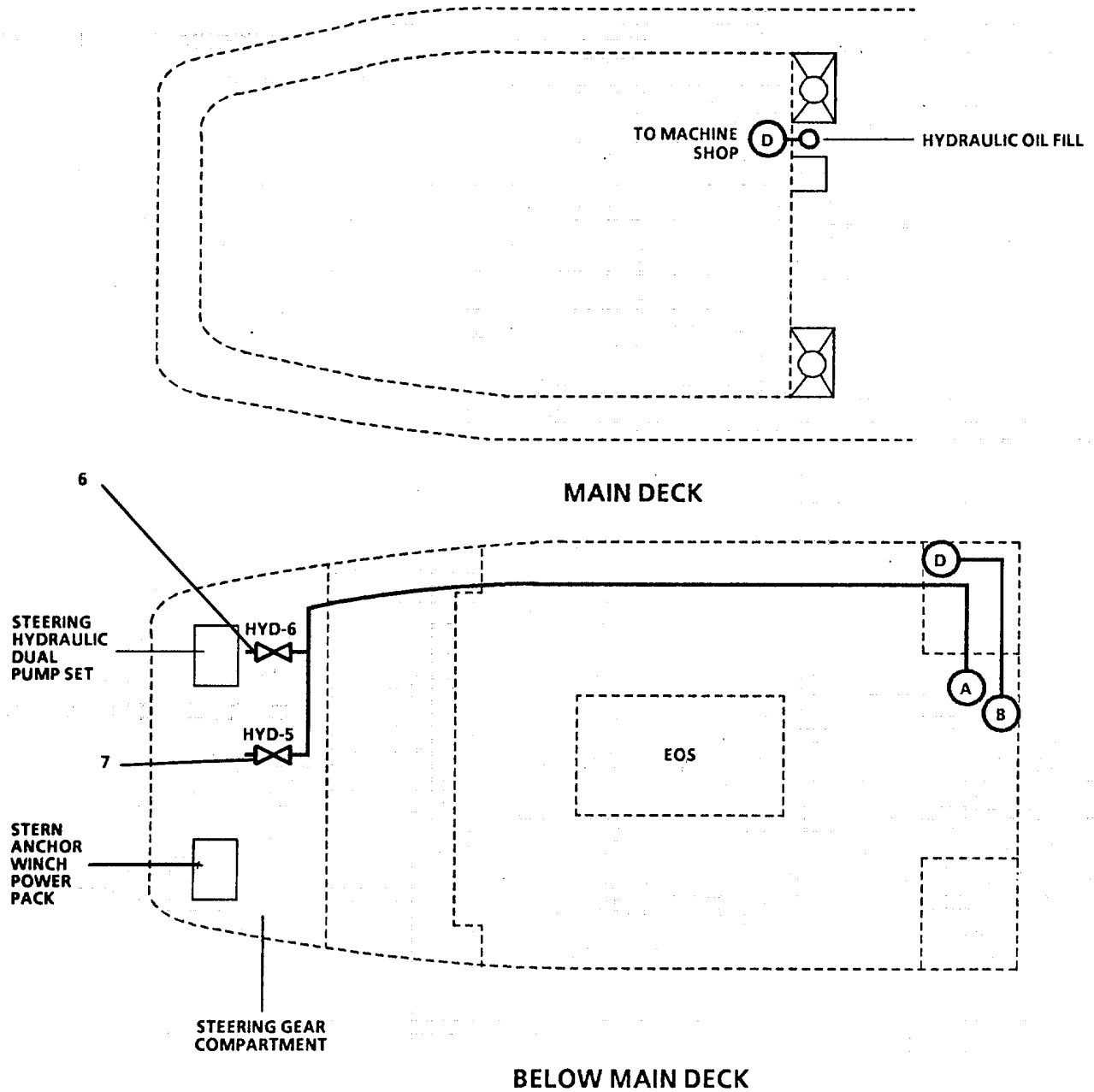

**LEGEND:**

- 6. HYD-6, PWR PACK FILL
- 7. HYD-5, PWR PACK FILL

FIGURE 1-46. Hydraulic Oil Supply Piping System (Sheet 3 of 3).

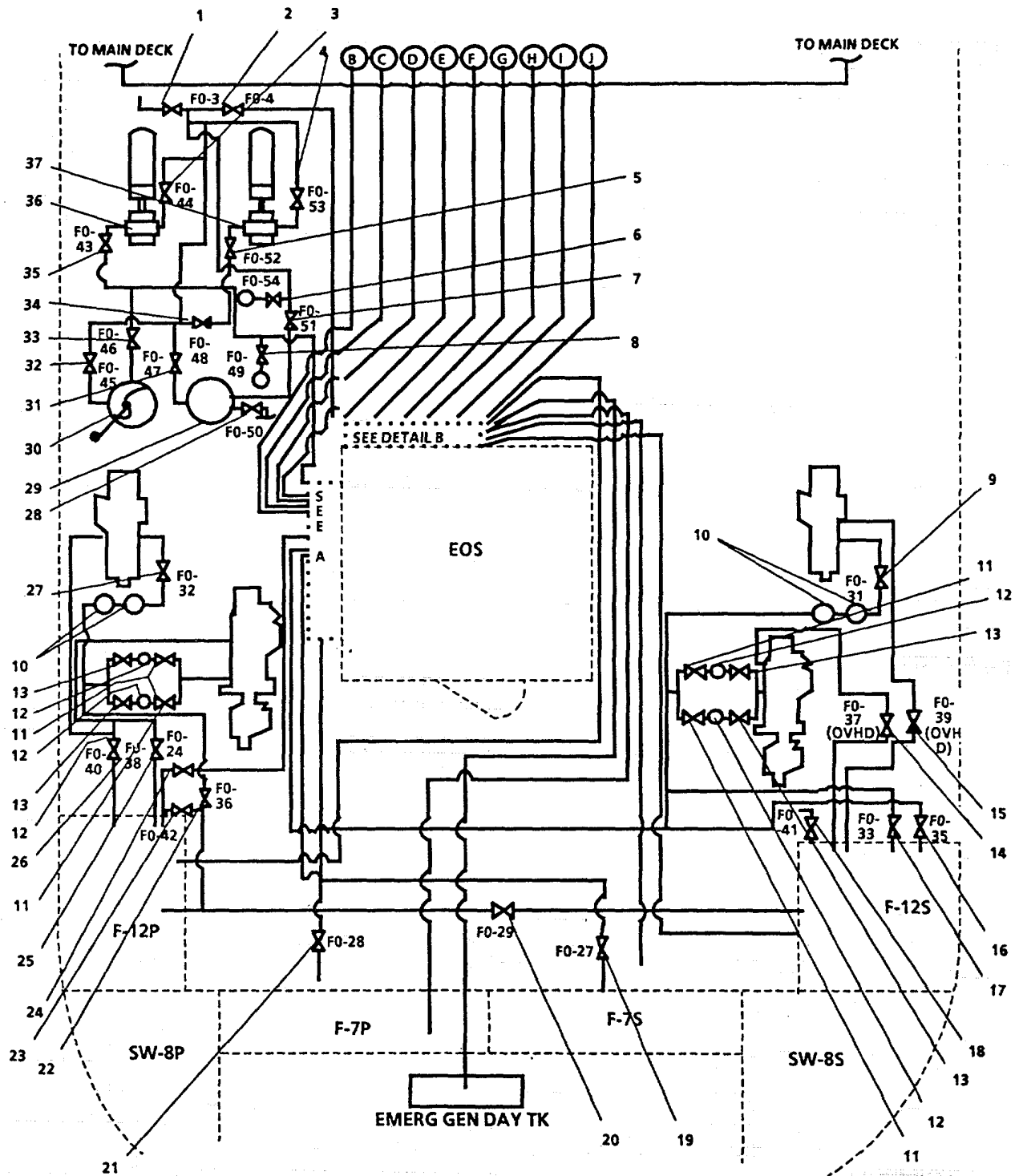

FIGURE 1-47. Fuel Oil Filter, Transfer, and Supply Piping System (Sheet 1 of 5).

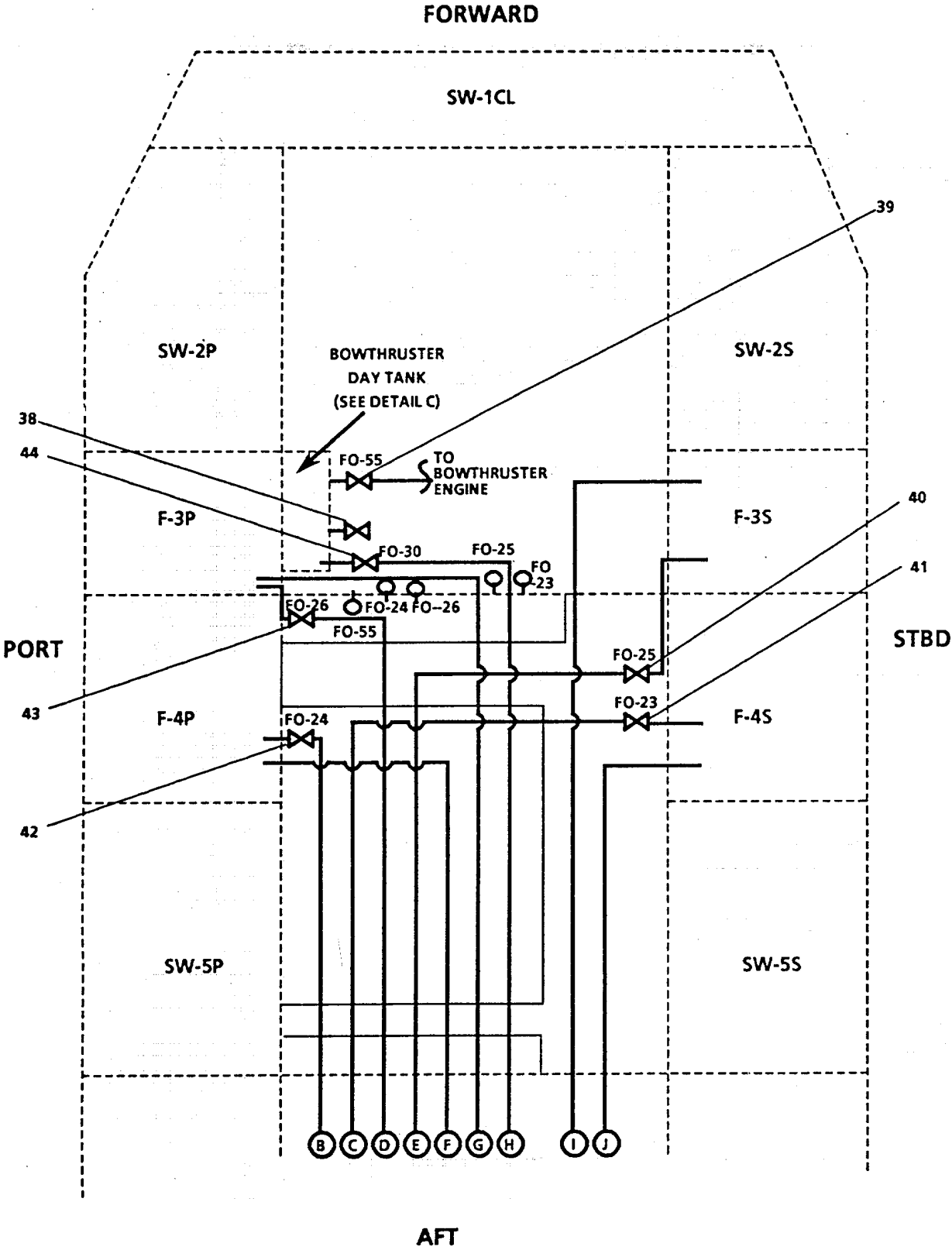

FIGURE 1-47. Fuel Oil Filter, Transfer, and Supply Piping System (Sheet 2 of 5).

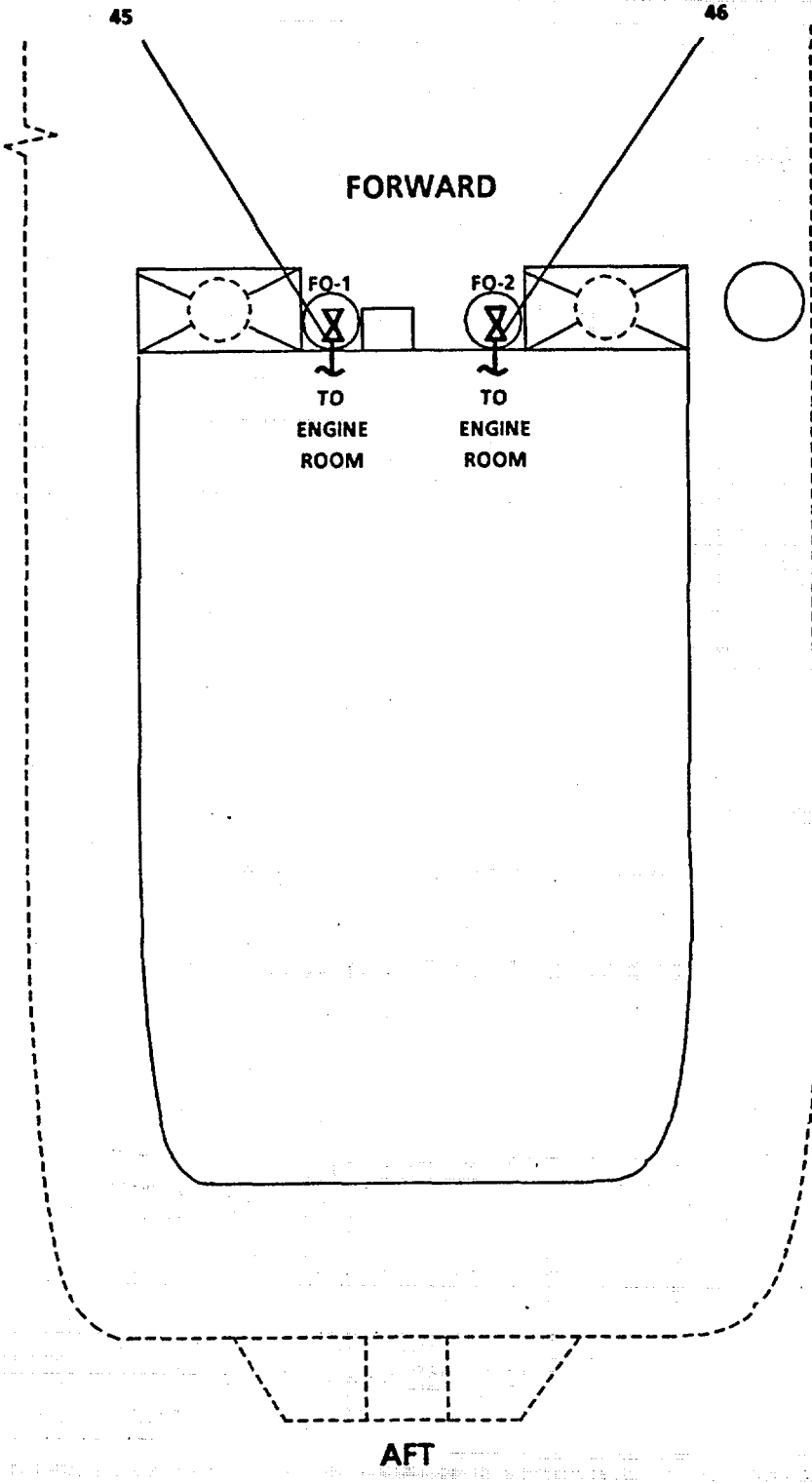
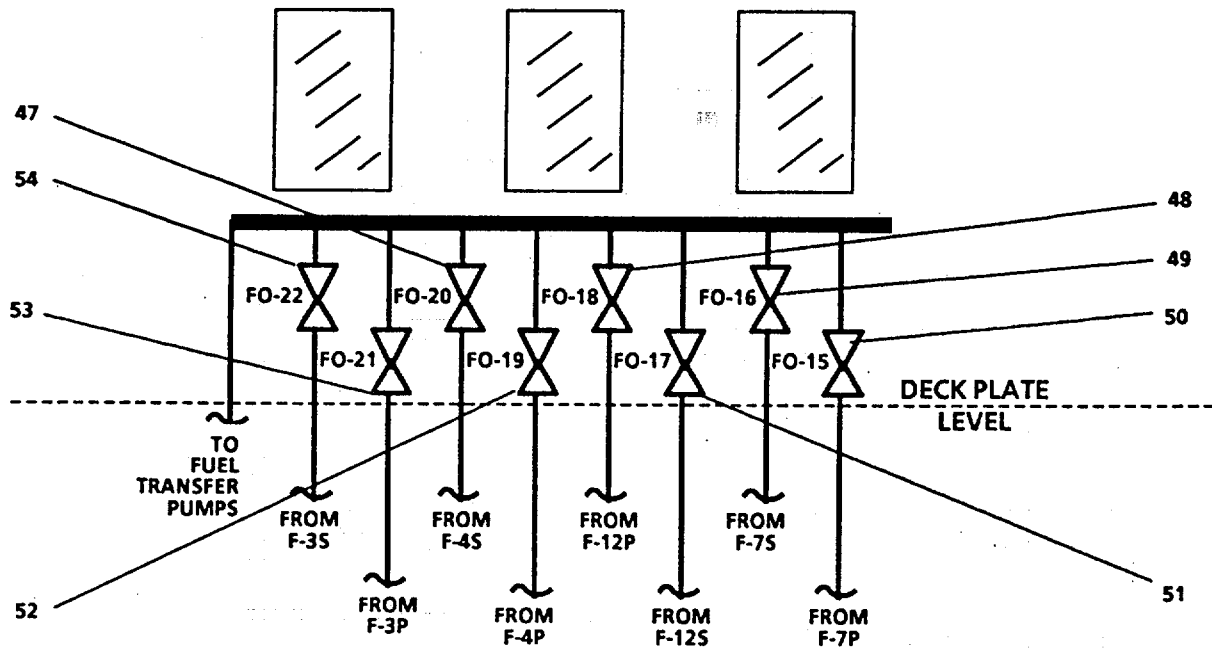

FIGURE 1-47. Fuel Oil Filter, Transfer, and Supply Piping System (Sheet 3 of 5).

**DETAIL A  
PORT EXTERIOR BULKHEAD  
OF EOS (FORWARD)**



**DETAIL B  
FORWARD EXTERIOR BULKHEAD  
OF EOS (PORT)**

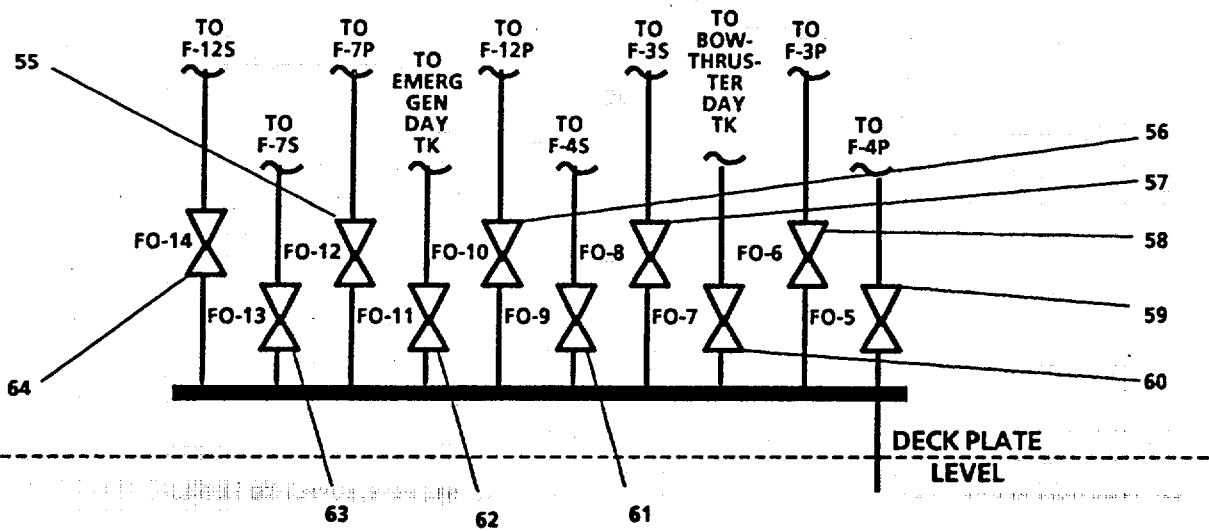

FIGURE 1-47. Fuel Oil Filter, Transfer, and Supply Piping System (Sheet 4 of 5).

LEGEND

- |   |  |
|---|--|
| 1. FO-3, ISLN-FILL/DISCH STATIONS.                    | 33. FO-46, HAND PUMP SUCT                |
| 2. FO-4, SUPPY TO FO SUPPLY MANF.                     | 34. FO-48, BY-PASS FILTER/SEPARATOR      |
| 3. FO-44, DISCH -NO.2 XFR PUMP.                       | 35. FO-43, SUCT-NO. 2 XFR PUMP           |
| 4. FO-53, DISCH- NO. 1 XFR PUMP.                      | 36. NO. 2 XFR PUMP                       |
| 5. FO-52, SUCT-NO. I XFR PUMP.                        | 37. NO. 1 XFR PUMP                       |
| 6. FO-54, PUMP DISCH PRESS GAGE.                      | 38. BOW THRUSTER DAY TK DRAIN            |
| 7. FO-51, FILTER/SEPARATOR OUTLET.                    | 39. FO-55, SUPPLY TO BOW THRUSTER ENGINE |
| 8. FO-49, PUMP SUCT PRESS GAGE.                       | 40. FO-25, SUCT FR TK F-3S               |
| 9. FO-31, SUPPLY TO STBD SSDG.                        | 41. FO-23, SUCT FR TK F-4S               |
| 10. SSDG FUEL FILTERS.                                | 42. FO-24, SUCT FR TK F-4P               |
| 11. MN ENG FILTER DISCH VALVE.                        | 43. FO-26, SUCT FR TK F-3P               |
| 12. MN ENG FILTER.                                    | 44. FO-30, SUPPLY TO BOW THRUSTER DAY TK |
| 13. MN ENG FILTER INLET VALVE.                        | 45. FO-1, FUEL OIL FILUDISCH             |
| 14. FO-37, RETURN FR STBD MN ENG TO DAY TK F-12S.     | 46. FO-2, FUEL OIL FILL/DISCH            |
| 15. FO-39, RETURN FR STBD SSDG TO DAY TK F-12S.       | 47. FO-20, SUCT FR TK F-4S               |
| 16. FO-35, SUCT FR DAY TK F-12S.                      | 48. FO-18, SUCT FR TK F-12P              |
| 17. FO-33, DAY TK F-12S SUPPLY TO STBD MN ENG & SSDG. | 49. FO-16, SUCT FR TK F-7S               |
| 18. FO-41, DRAIN FR DAY TK F-12S.                     | 50. FO-15, SUCT FR TK F-7P               |
| 19. FO-27, SUCT FR TK F-7S.                           | 51. FO-17, SUCT FR TK F-12S              |
| 20. FO-29, CROSS CONN - DAY TKS.                      | 52. FO-19, SUCT FR TK F-4P               |
| 21. FO-28, SUCT FR TK F-7P.                           | 53. FO-21, SUCT FR TK F-3P               |
| 22. FO-36, DAY TK F-12P SUPPLY TO PORT MN ENG & SSDG. | 54. FO-22, SUCT FR TK F-3S               |
| 23. FO-42, DRAIN FR DAY TK F-12P.                     | 55. FO-12, SUPPLY TO TK F-7P             |
| 24. FO-34, SUCT FR DAY TK F-12P.                      | 56. FO-10, SUPPLY TO DAY TK F-12P        |
| 25. FO-38, RETURN FR PORT MN ENG TO DAY TK F-12P.     | 57. FO-8, SUPPLY TO TK F-3S              |
| 26. FO-40, RETURN FR PORT SSDG TO DAY TK F-12P.       | 58. FO-6, SUPPLY TO TK F-3P              |
| 27. FO-32, SUPPLY TO PORT SSDG.                       | 59. FO-5, SUPPLY TO TK F-4P              |
| 28. FO-50, DRAIN TO SLUDGE TK.                        | 60. FO-7, SUPPLY TO BOW THRUSTER DAY TK  |
| 29. FUEL FILTER/COALESCER.                            | 61. FO-9, SUPPLY TO TK F-4S              |
| 30. FUEL TRANSFER HAND PUMP.                          | 62. FO-11, SUPPY TO EMER GEN DAY TK      |
| 31. FO-47, FILTER/SEPARATOR INLET.                    | 63. FO-13, SUPPY TO TK F-7S              |
| 32. FO-45, HAND PUMP DISCH.                           | 64. FO-14, SUPPY TO TK F-12S             |

FIGURE 1-47. Fuel Oil Filter, Transfer, and Supply Piping System (Sheet 5 of 5).

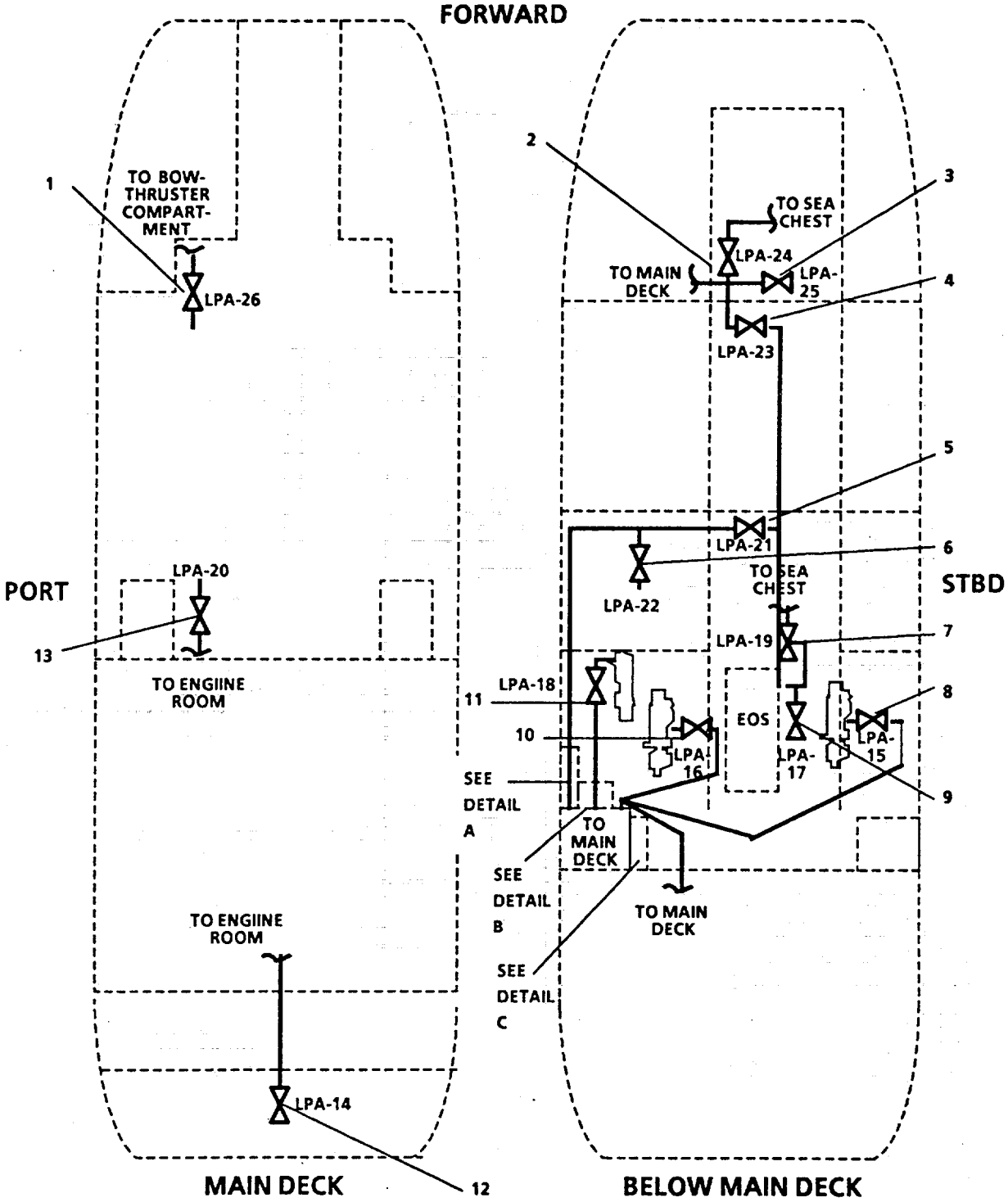

FIGURE 1-48. Compressed Air Piping System (Sheet 1 of 5)



DETAIL A

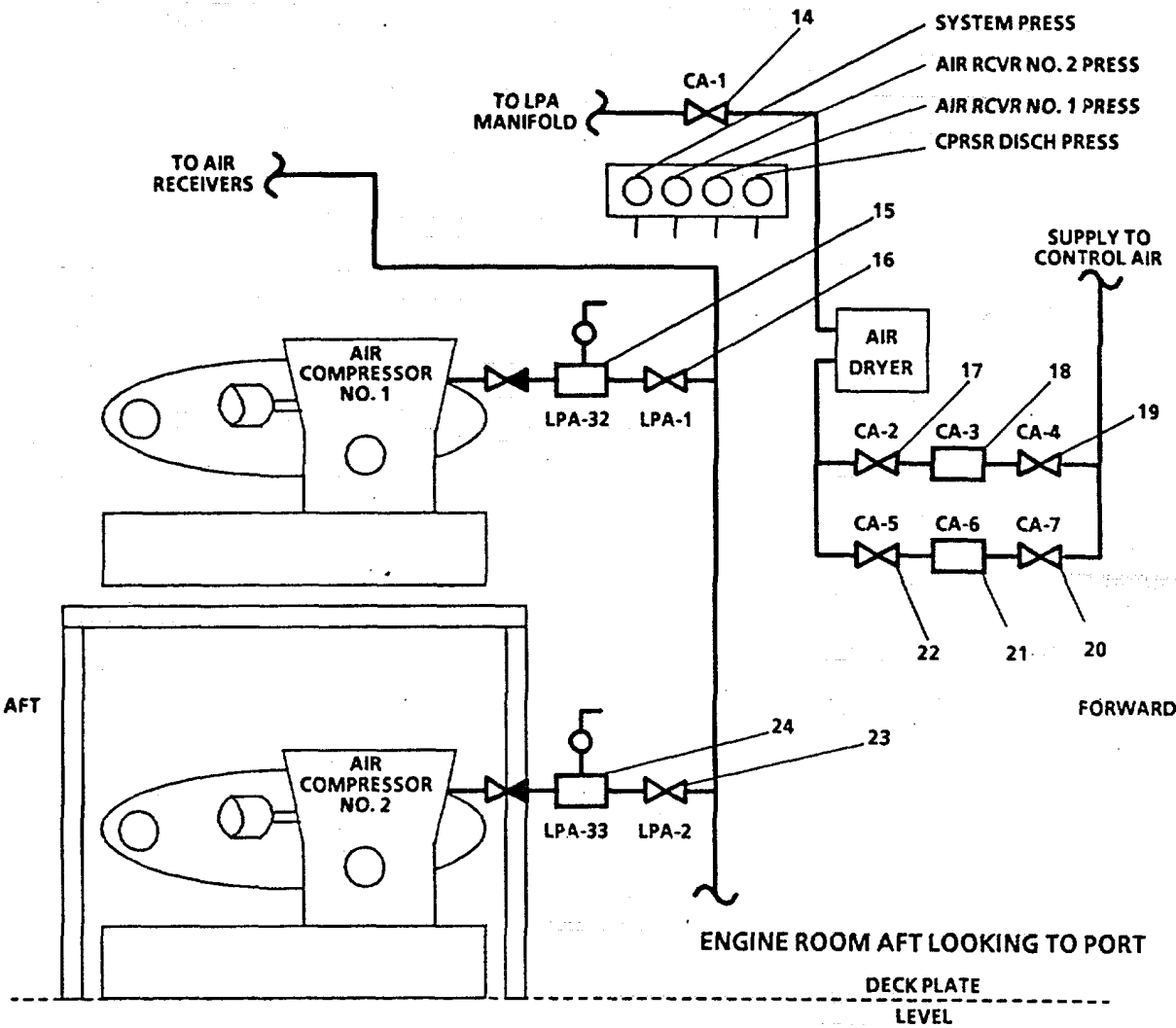

FIGURE 1-48. Compressed Air Piping System (Sheet 2 of 5)

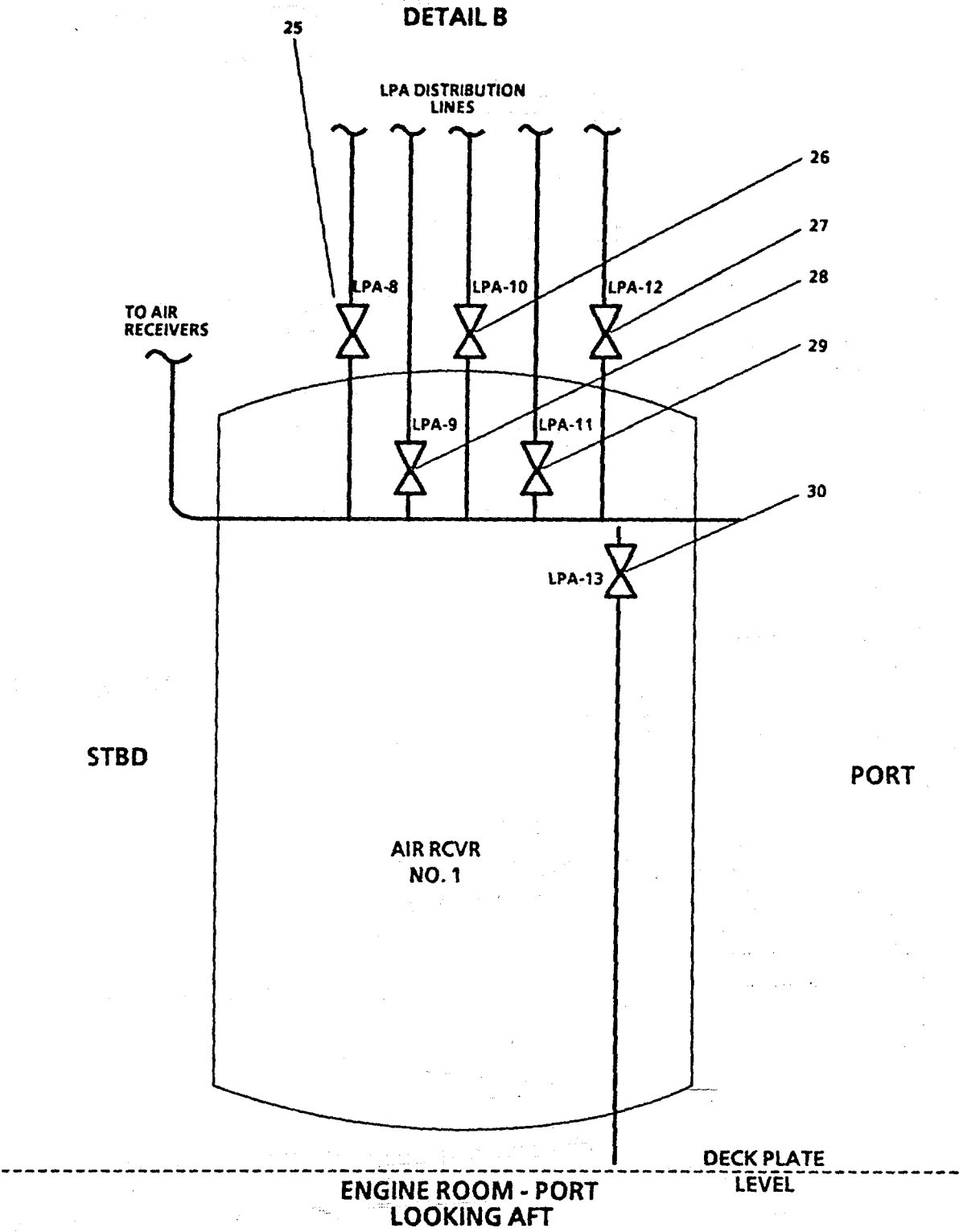

FIGURE 1-48. Compressed Air Piping System (Sheet 3 of 5).

DETAIL C

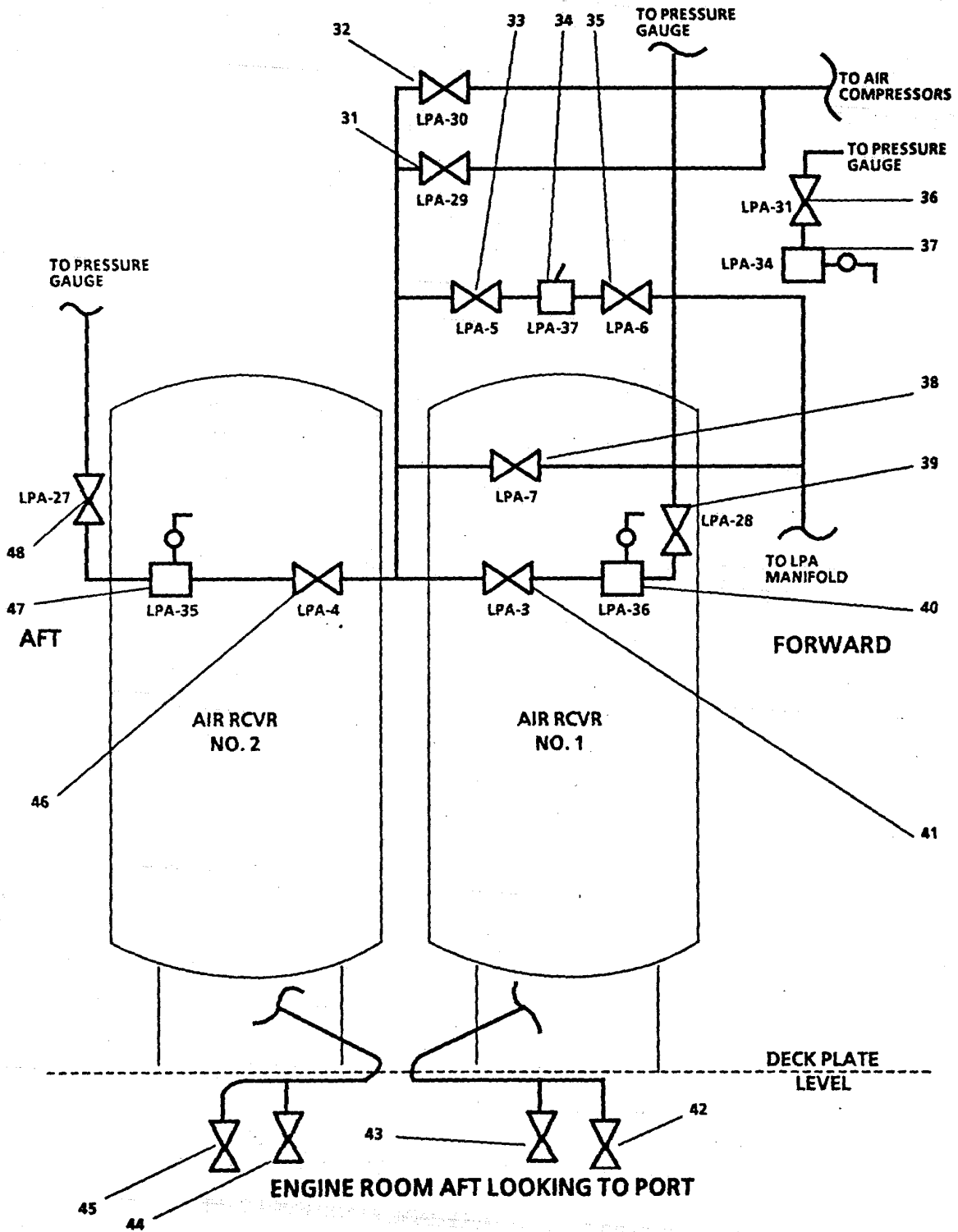

FIGURE 1-48. Compressed Air Piping System (Sheet 4 of 5).

**LEGEND**

- |  |   |
|--|---|
| 1. LPA-26, SUPPLY TO SVCE AIR          | 25. LPA-8, SUPPLY TO CONTROL AIR        |
| 2. LPA-24, SEA CHEST BLWDN             | 26. LPA-10, SUPPLY TO MN ENG-STBD       |
| 3. LPA-25, SUPPLY TO SVCE AIR          | 27. LPA-12, SUPPLY TO SSDG-PORT         |
| 4. LPA-23, SUPPLY TO FWD SVCE AIR      | 28. LPA-9, SUPPLY TO SVCE AIR           |
| 5. LPA-21, SUPPLY TO FWD SVCE AIR      | 29. LPA-11, SUPPLY TO MN ENG-STBD       |
| 6. LPA-22, SUPPLY TO SVCE AIR          | 30. LPA-13, MANIFOLD DRAIN              |
| 7. LPA-19, SEA CHEST BLWDN             | 31. LPA-29, TO AIR CPRSR UNLOADERS      |
| 8. LPA-15, SUPPLY TO MN ENG-STBD       | 32. LPA-30, PRESS SW                    |
| 9. LPA-17, SUPPLY TO SVCE AIR          | 33. LPA-5, SUPPLY TO PRESS RDCR         |
| 10. LPA-16, SUPPLY TO MN ENG-PORT      | 34. LPA-37, PRESS RDCR                  |
| 11. LPA-18, SUPPLY TO SSDG-PORT        | 35. LPA-6, SUPPLY TO MANIF              |
| 12. LPA-14, SUPPLY TO SVCE AIR         | 36. LPA-31, PRESS GAGE                  |
| 13. LPA-20, SUPPLY TO SVCE AIR         | 37. LPA-34, RELIEF VLV                  |
| 14. CA-1, CONTROL AIR CUTOUT           | 38. LPA-7, BYPASS TO MANF               |
| 15. LPA-32, RELIEF VLV-AIR CPRSR NO. 1 | 39. LPA-28, PRESS GAGE - AIR RCVR NO. 1 |
| 16. LPA-1, DISCH-AIR CPRSR NO. 1       | 40. LPA-36, RELIEF VLV-AIR RCVR NO. 1   |
| 17. CA-2, ISLN-SEP/RGLTR               | 41. LPA-3, ISLN-AIR RCVR NO. 1          |
| 18. CA-3, SEP/RGLTR                    | 42. AIR RECEIVER DRAIN                  |
| 19. CA-4, SUPPLY TO CONTROL AIR        | 43. ISOLATION VALVE-AIR WATER SEPARATOR |
| 20. CA-7, SUPPLY TO CONTROL AIR        | 44. ISOLATION VALVE-AIR WATER SEPARATOR |
| 21. CA-6, SEP/RGLTR                    | 45. AIR RECEIVER DRAIN                  |
| 22. CA-5, ISLN-SEP/RGTR                | 46. LPA-4, ISLN-AIR RCVR NO. 2          |
| 23. LPA-2, DISCH-AIR CPRSR NO. 2       | 47. LPA-35, RELIEF VLV-AIR RCVR NO. 2   |
| 24. LPA-33, RELIEF VLV-AIR CPRSR NO. 2 | 48. LPA-27, PRESS GAGE-AIR RCVR NO. 2   |

FIGURE 1-48. Compressed Air Piping System (Sheet 5 of 5).

1-40. **Lubricating Oil Transfer and Purification Piping System.** The lubricating oil transfer and purification piping system supplies clean lubricating oil for proper operation of the main propulsion engines. The system also transfers lubricating oil from the storage tank to the main engines and ships service diesel generator engines sumps. The system also draws lubricating oil from the main engines sumps. Prelubricating the main engines after an extended shutdown period is possible with use of the prelube pump. The system can be aligned to transfer dirty lubricating oil from the main, SSDG, and bowthruster engines and reverse reduction gearboxes to the dirty oil tank. System alignment is maintained by a combination of valves and hand pumps as shown in FIGURE 1-49. Dirty oil and sludge are discharged from the system via the dirty oil pump to port or starboard dirty oil discharge deck connections. Power for the lube oil purifier unit and heater, lube oil prelube pump, and dirty oil pump is supplied by the auxiliary machinery motor control center. Each has a START/STOP pushbutton adjacent to the unit and run indicator lamps on the engine room operating station engine room console panel. Containers for replenishing lubricating oil at the bowthruster engine, main reduction gears, and emergency generator diesel engine, may be filled at the storage tank container fill valve.

1-41. **Oily Water Separator Piping System.** The oily water separator piping system consists of a three-stage coalescer oil-water separator with pumps, motors and oil content alarm. The system separates and removes nonsoluble oil, solids, and entrained air from the bilge water before it is discharged overboard. System control is maintained through a combination of valves as shown in FIGURE 1-50. Power for the oil water separator is supplied by the MISC MCHRY POWER PANEL P204. A running indicator is provided on the engine room console panel.

1-42. **Sewage Piping System.** The sewage piping system collects and routes ship's sewage to the sewage treatment device and then to a through-hull overboard discharge. The sewage treatment device uses natural bacteria to decompose solids in the sewage. The decomposed sewage is then treated with chlorine prior to overboard discharge. The sewage treatment device is supplied with power by the MISC MCHRY PANEL P204, through a 240/120 Vac step-down transformer. Controls for the sewage treatment device are located on the unit.

1-43. **Propeller Shaft, Propeller, and Shaft Brake.** The propeller shaft transfers power provided by the main reduction gear and clutch to the propeller, which converts it to thrust required to move the vessel. The shaft brake stops and holds the propeller shaft when no torque is applied. The shaft is connected to the main reduction gear via the propeller shaft flange. The shaft is lubricated by water from the stern tube lubrication piping system. The air actuated shaft brake stops the propeller shaft rotation when torque is removed from the shaft. The brake is automatically actuated. Shaft locks allow manual locking of each shaft.

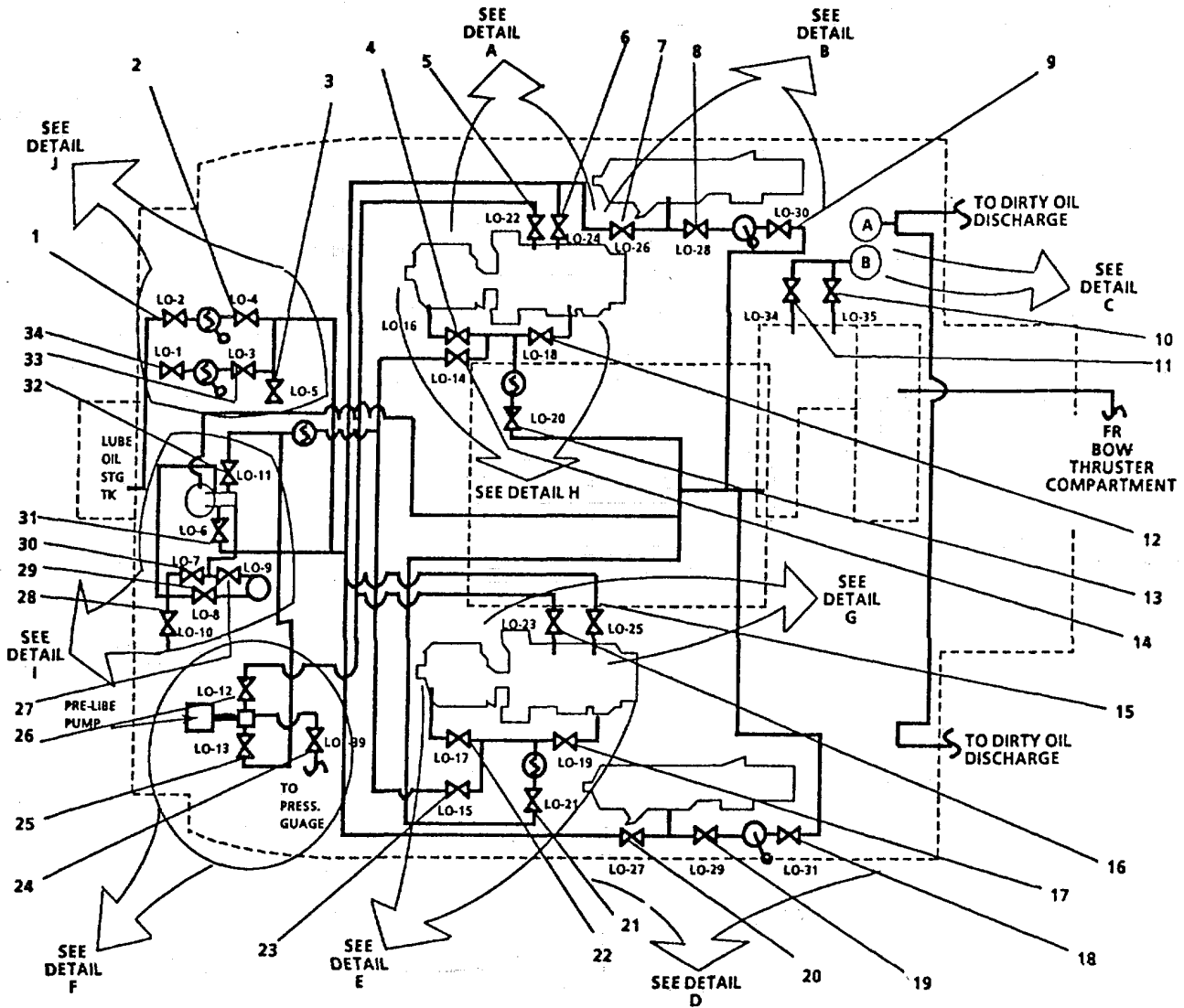

**LEGEND**

- |    |  |    |                               |
|----|--|----|-------------------------------|
| 1  | LO-2, STORAGE TK SUPPLY                  | 21 | LO-21, MN ENG SUMP DISCH      |
| 2  | LO-4, HAND PUMP NO. 2 DISCH              | 22 | LO-17, RDCN GEAR SUCT-STBD    |
| 3  | LO-5, HAND SUPPLY                        | 23 | LO-15, PRE-LUBE PURIFIER SUCT |
| 4  | LO-16, RDCN GEAR SUCT-PORT               | 24 | LO-39, PRESSURE GAGE ISLN     |
| 5  | LO-22, PRE-LUBE RETURN-PORT ENG          | 25 | LO-13, PRE-LUBE PUMP SUCTION  |
| 6  | LO-24, SUMP SUPPLY/PURIFIER RTN-PORT ENG | 26 | LO-12, PRE-LUBE PUMP DISCH    |
| 7  | LO-26, SUMP SUPPLY                       | 27 | LO-9, PRE-HEATER SUPPLY       |
| 8  | LO-28, SUMP SUCT-SSDG                    | 28 | LO-10, PRE-HEATER VENT        |
| 9  | LO-30, SUMP DISCH-SSDG                   | 29 | LO-8, PRE-HEATER OUTLET       |
| 10 | LO-35, SLUDGE TK SUCT                    | 30 | LO-7, PRE-HEATER BY-PASS      |
| 11 | LO-34, DIRTY OIL TK SUCT                 | 31 | LO-6, LO PURIFIER DISCH       |
| 12 | LO-18-SUMP SUCT-PORT ENG                 | 32 | LO-11, PURIFIER SUCTION       |
| 13 | LO-20, MN ENG SUMP DISCH                 | 33 | LO-3, HAND PUMP NO. 1 DISCH   |
| 14 | LO-14, PRE-LUBE PURIFIER SUCT            | 34 | LO-1, STORAGE TK SUPPLY       |
| 15 | LO-25, SUMP SUPPLY/PURIFIER RTN-STBD ENG | 35 | LO-33, SUMP DISCH-BOW ENG     |
| 16 | LO-23, PRE-LUBE RETURN-STBD ENG          | 36 | HAND SUPPLY                   |
| 17 | LO-19, SUMP SUCT-STBD ENG                | 37 | LO-32, SUMP SUCT-BOW ENG      |
| 18 | LO-31, SUMP DISCH-SSDG                   | 38 | LO-37, DIRTY OIL PUMP DISCH   |
| 19 | LO-29, SUMP SUCT-SSDG                    | 39 | LO-36, DIRTY OIL PUMP SUCT    |
| 20 | LO-27, SUMP SUPPLY                       |    |                               |

FIGURE 1-49. Lubricating Oil Transfer and Purification Piping System (Sheet 1 of 8).

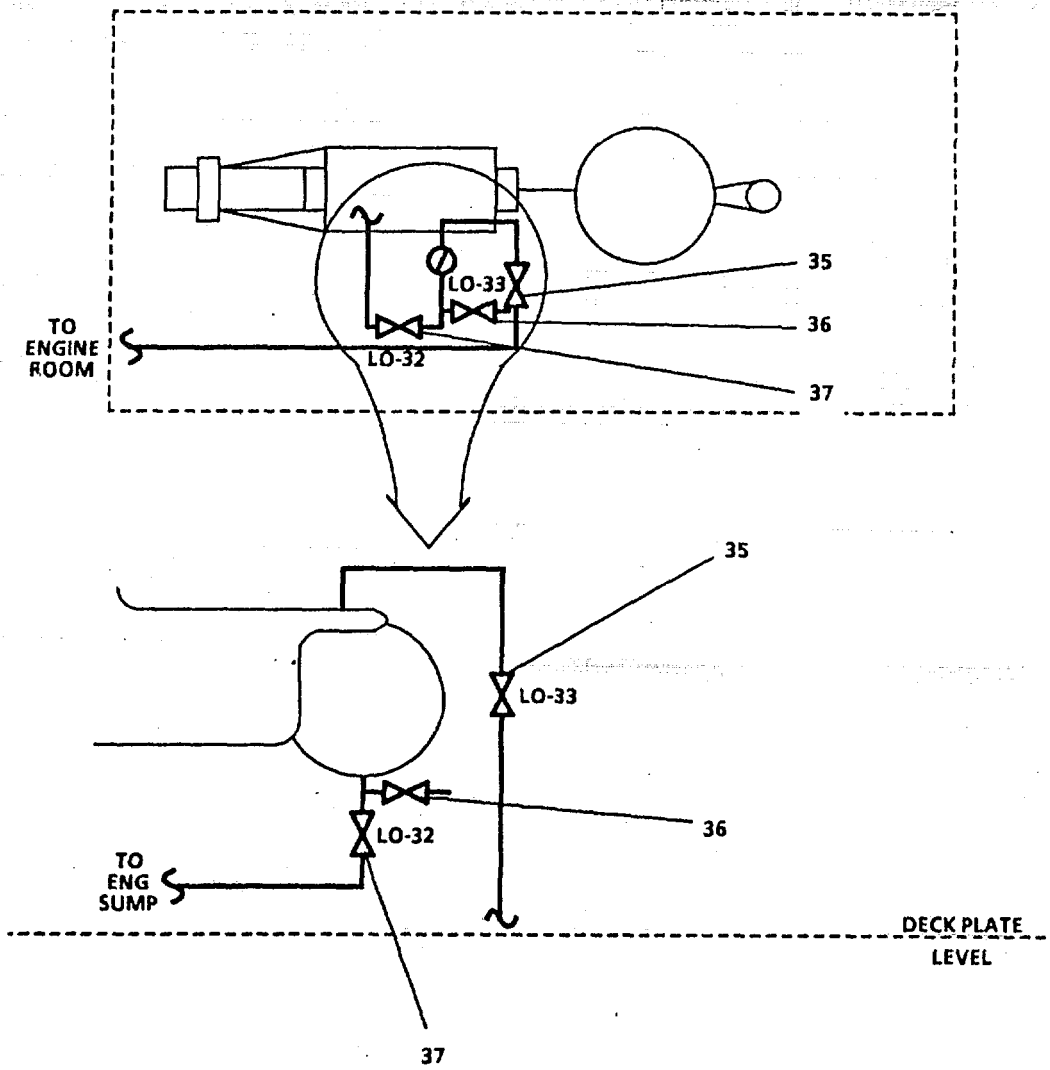
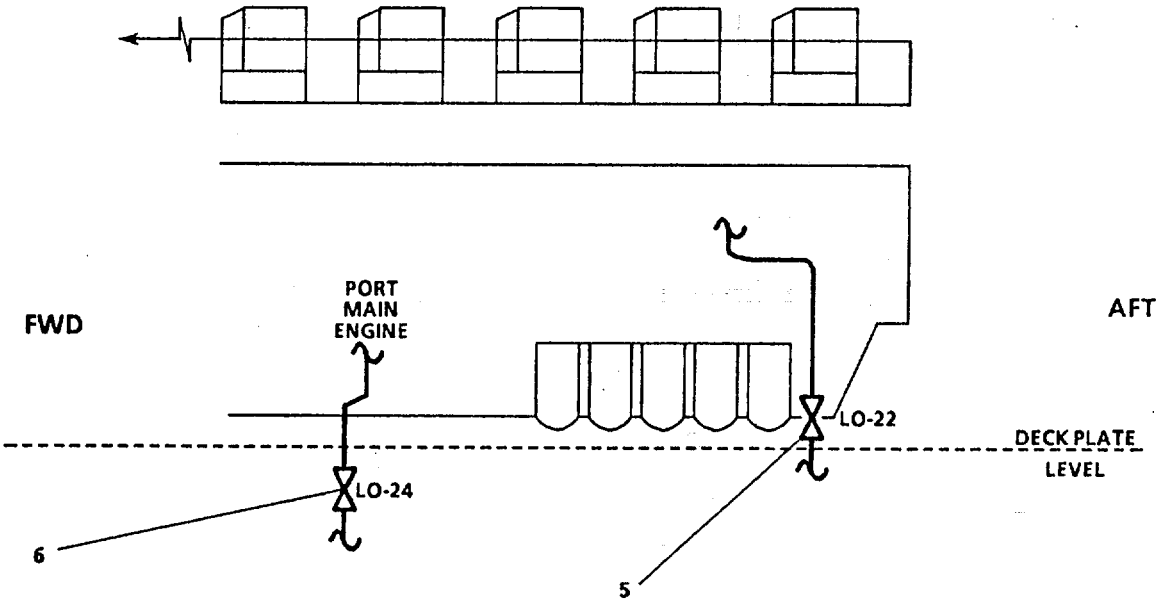

FIGURE 1-49. Lubricating Oil Transfer and Purification Piping System (Sheet 2 of 8).



DETAIL B

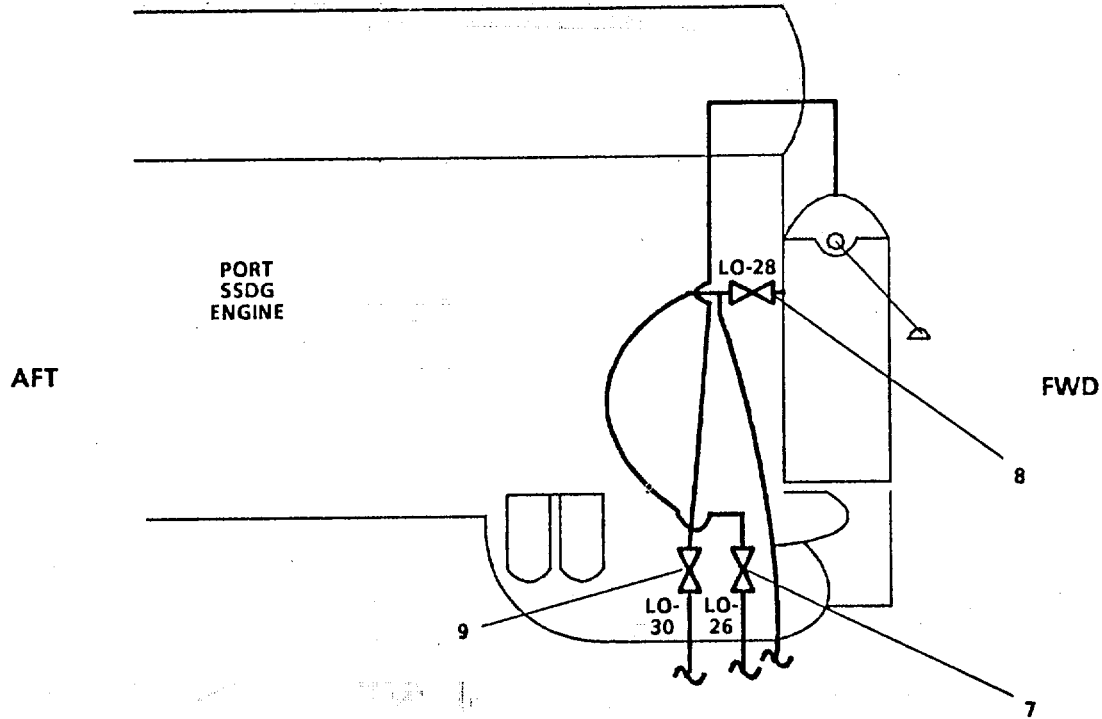

FIGURE 1-49. Lubricating Oil Transfer and Purification Piping System (Sheet 3 of 8).



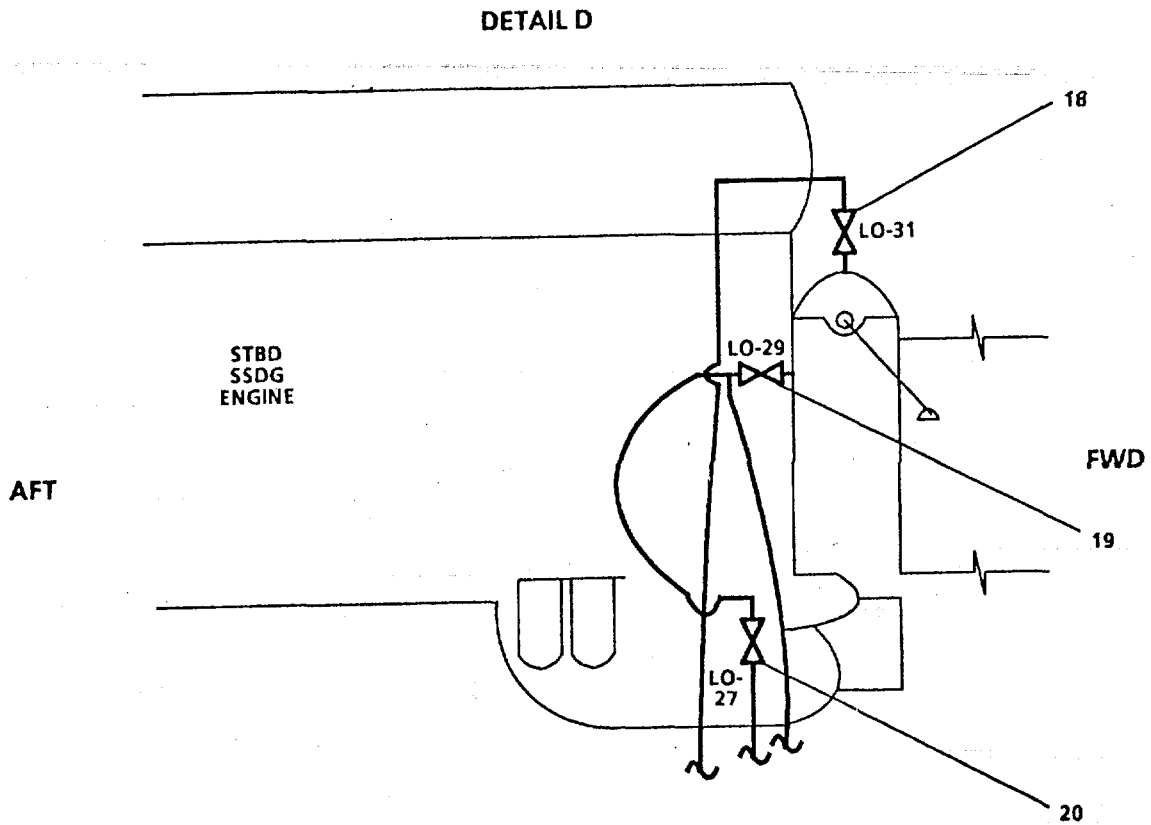
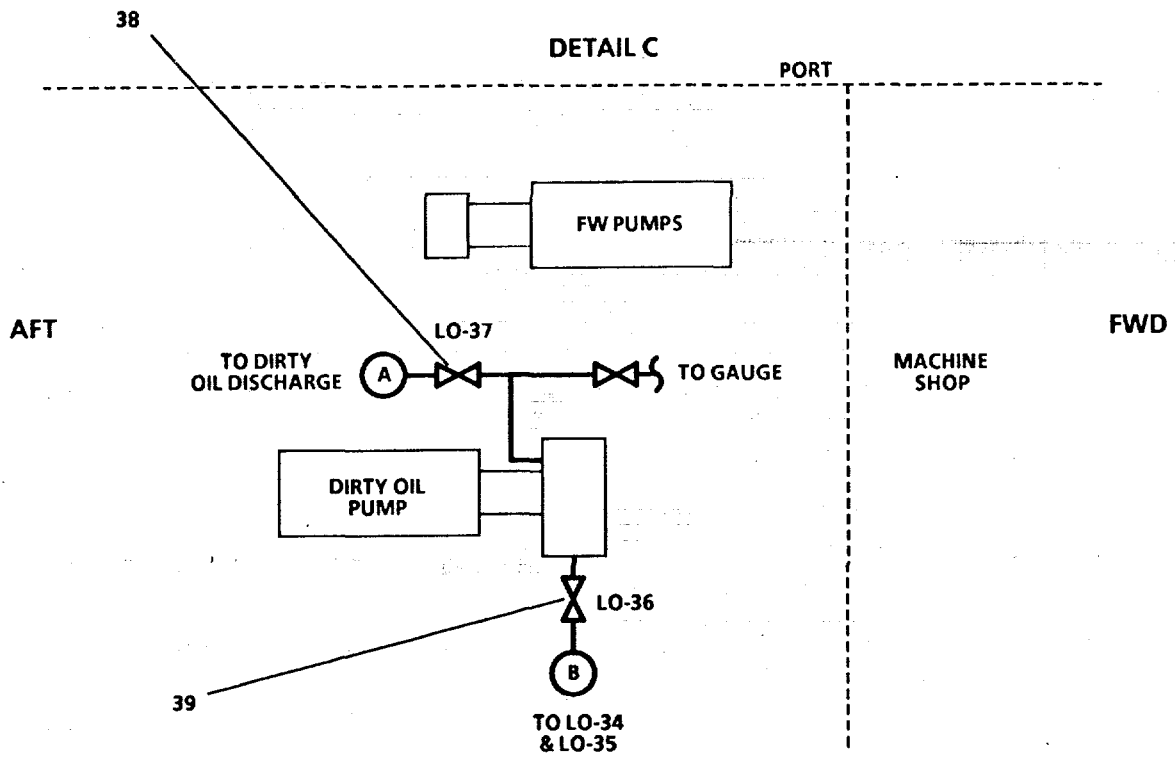

FIGURE 1-49. Lubricating Oil Transfer and Purification Piping System (Sheet 4 of 8).

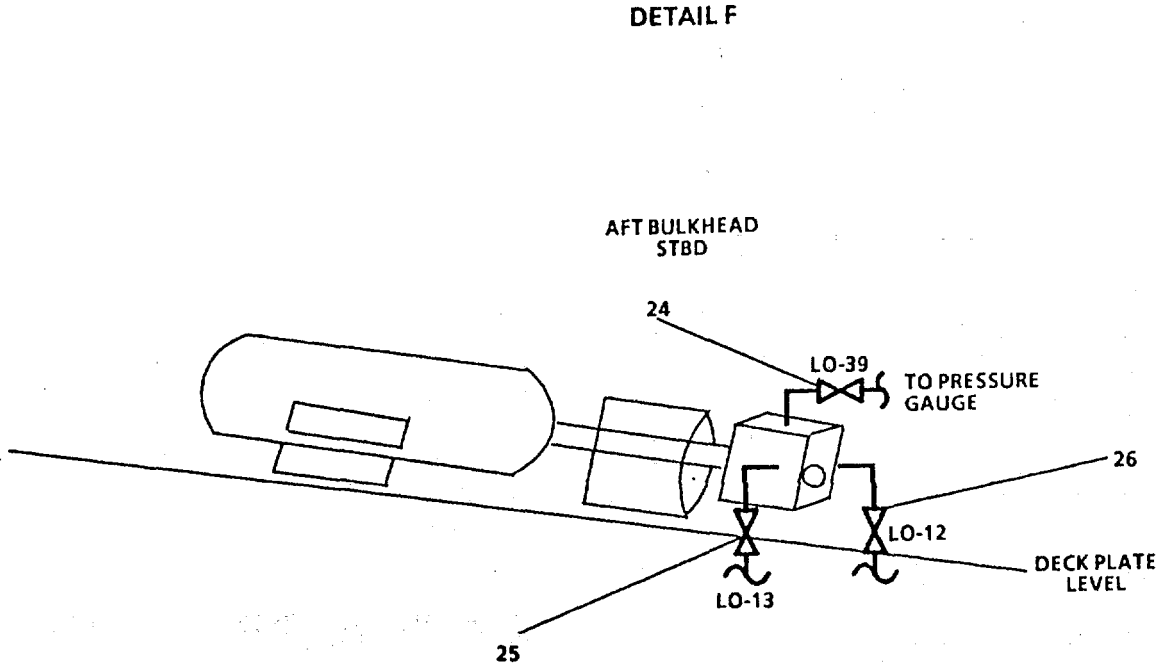
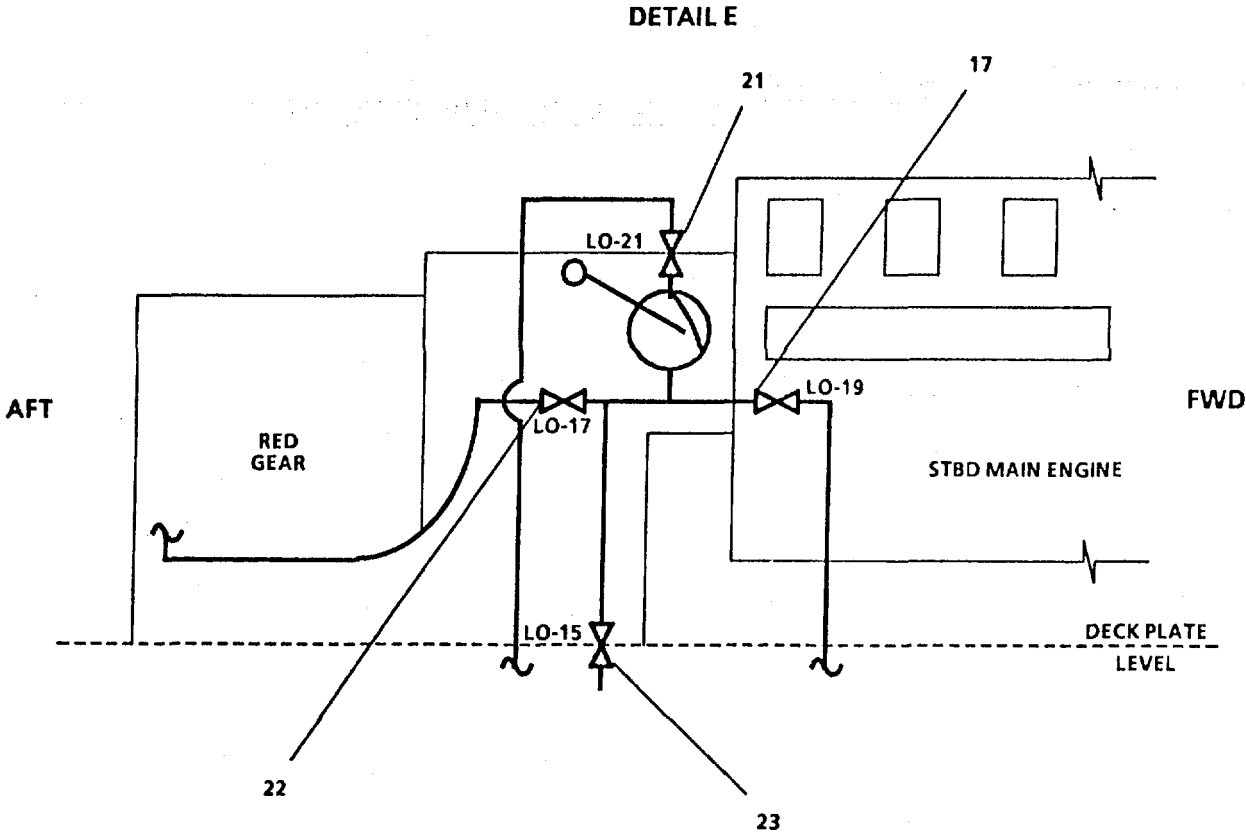

FIGURE 1-49. Lubricating Oil Transfer and Purification Piping System (Sheet 5 of 8).

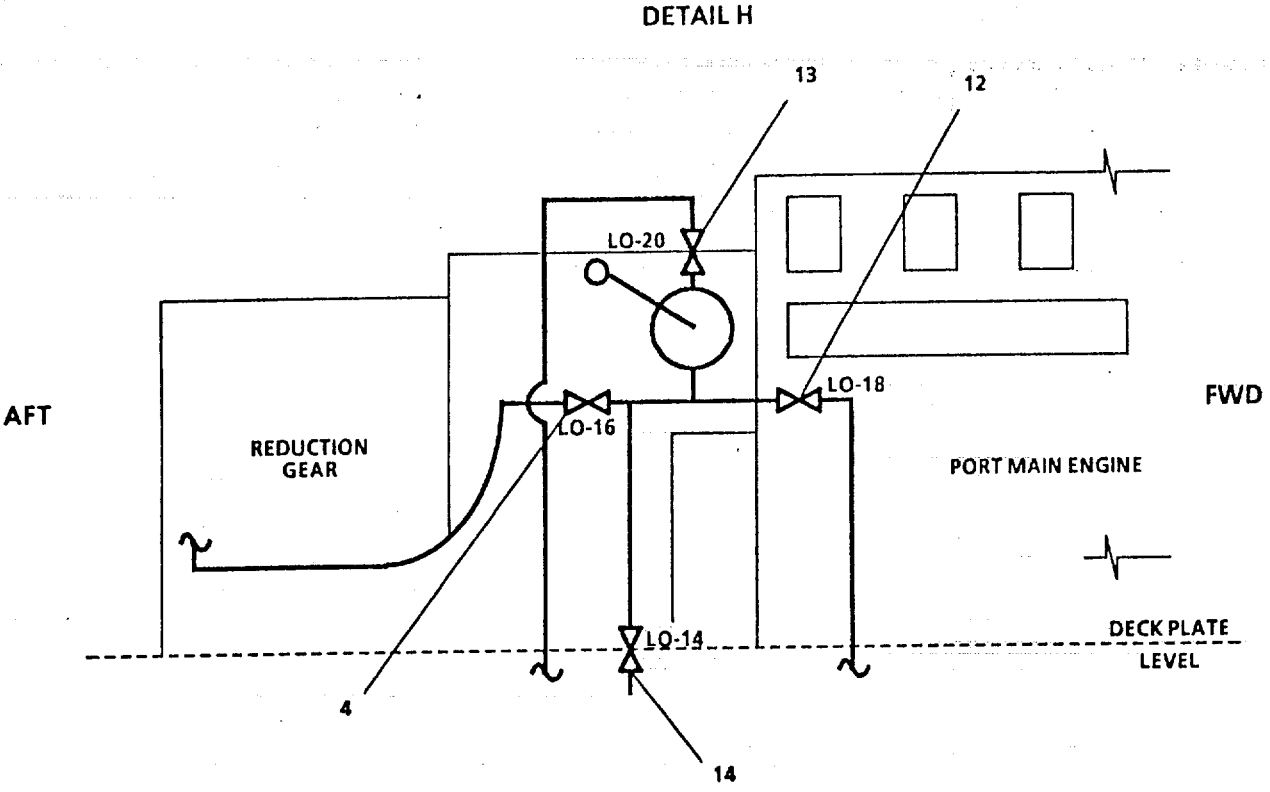
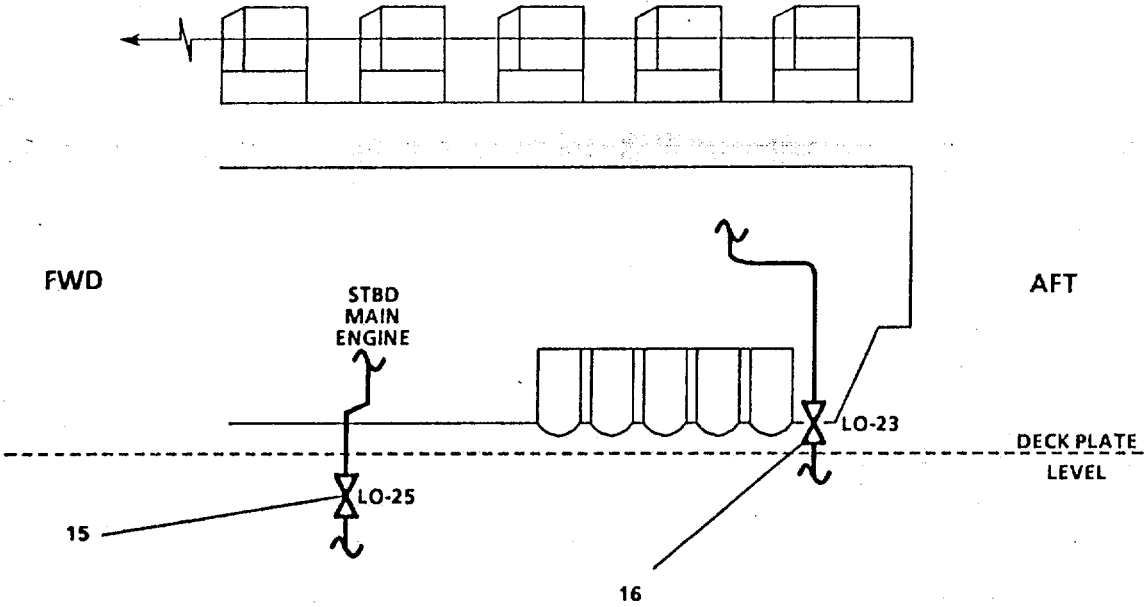

FIGURE 1-49. Lubricating Oil Transfer and Purification Piping System (Sheet 6 of 8).

DETAIL I  
LOOKING AFT

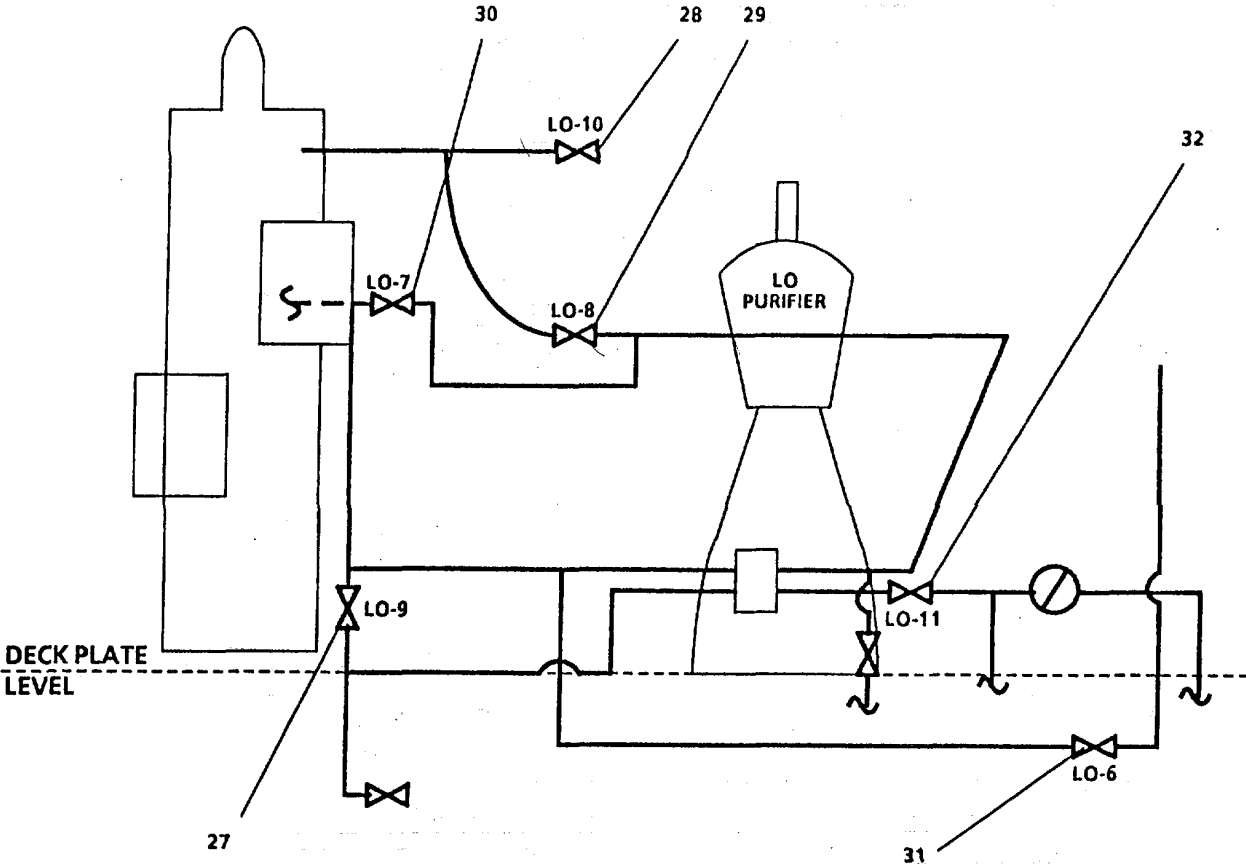
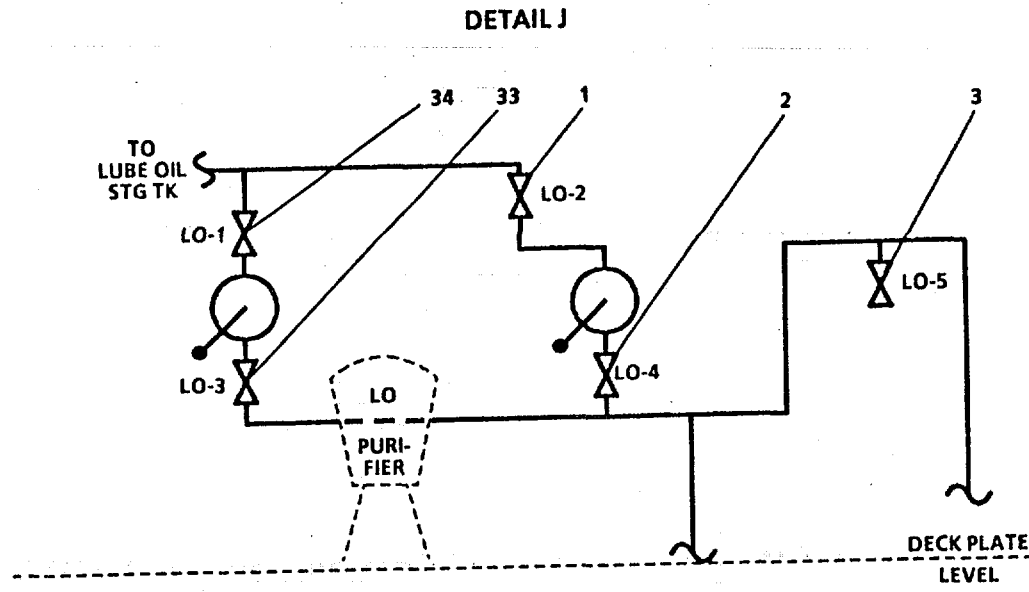

FIGURE 1-49. Lubricating Oil Transfer and Purification Piping System (Sheet 7 of 8).



**LEGEND**

- |    |  |    |                               |
|----|--|----|-------------------------------|
| 1  | LO-2, STORAGE TK SUPPLY                  | 21 | LO-21, MN ENG SUMP DISCH      |
| 2  | LO-4, HAND PUMP NO. 2 DISCH              | 22 | LO-17, RDCN GEAR SUCT-STBD    |
| 3  | LO-5, HAND SUPPLY                        | 23 | LO-15, PRE-LUBE PURIFIER SUCT |
| 4  | LO-16, RDCN GEAR SUCT-PORT               | 24 | LO-39, PRESSURE GAGE ISLN     |
| 5  | LO-22, PRE-LUBE RETURN-PORT ENG          | 25 | LO-13, PRE-LUBE PUMP SUCTION  |
| 6  | LO-24, SUMP SUPPLY/PURIFIER RTN-PORT ENG | 26 | LO-12, PRE-LUBE PUMP DISCH    |
| 7  | LO-26, SUMP SUPPLY                       | 27 | LO-9, PRE-HEATER SUPPLY       |
| 8  | LO-28, SUMP SUCT-SSDG                    | 28 | LO-10, PRE-HEATER VENT        |
| 9  | LO-30, SUMP DISCH-SSDG                   | 29 | LO-8, PRE-HEATER OUTLET       |
| 10 | LO-35, SLUDGE TK SUCT                    | 30 | LO-7, PRE-HEATER BY-PASS      |
| 11 | LO-34, DIRTY OIL TK SUCT                 | 31 | LO-6, LO PURIFIER DISCH       |
| 12 | LO-18-SUMP SUCT-PORT ENG                 | 32 | LO-11, PURIFIER SUCTION       |
| 13 | LO-20, MN ENG SUMP DISCH                 | 33 | LO-3, HAND PUMP NO. 1 DISCH   |
| 14 | LO-14, PRE-LUBE PURIFIER SUCT            | 34 | LO-1, STORAGE TK SUPPLY       |
| 15 | LO-25, SUMP SUPPLY/PURIFIER RTN-STBD ENG | 35 | LO-33, SUMP DISCH-BOW ENG     |
| 16 | LO-23, PRE-LUBE RETURN-STBD ENG          | 36 | HAND SUPPLY                   |
| 17 | LO-19, SUMP SUCT-STBD ENG                | 37 | LO-32, SUMP SUCT-BOW ENG      |
| 18 | LO-31, SUMP DISCH-SSDG                   | 38 | LO-37, DIRTY OIL PUMP DISCH   |
| 19 | LO-29, SUMP SUCT-SSDG                    | 39 | LO-36, DIRTY OIL PUMP SUCT    |
| 20 | LO-27, SUMP SUPPLY                       |    |                               |

FIGURE 1-49. Lubricating Oil Transfer and Purification Piping System (Sheet 8 of 8).

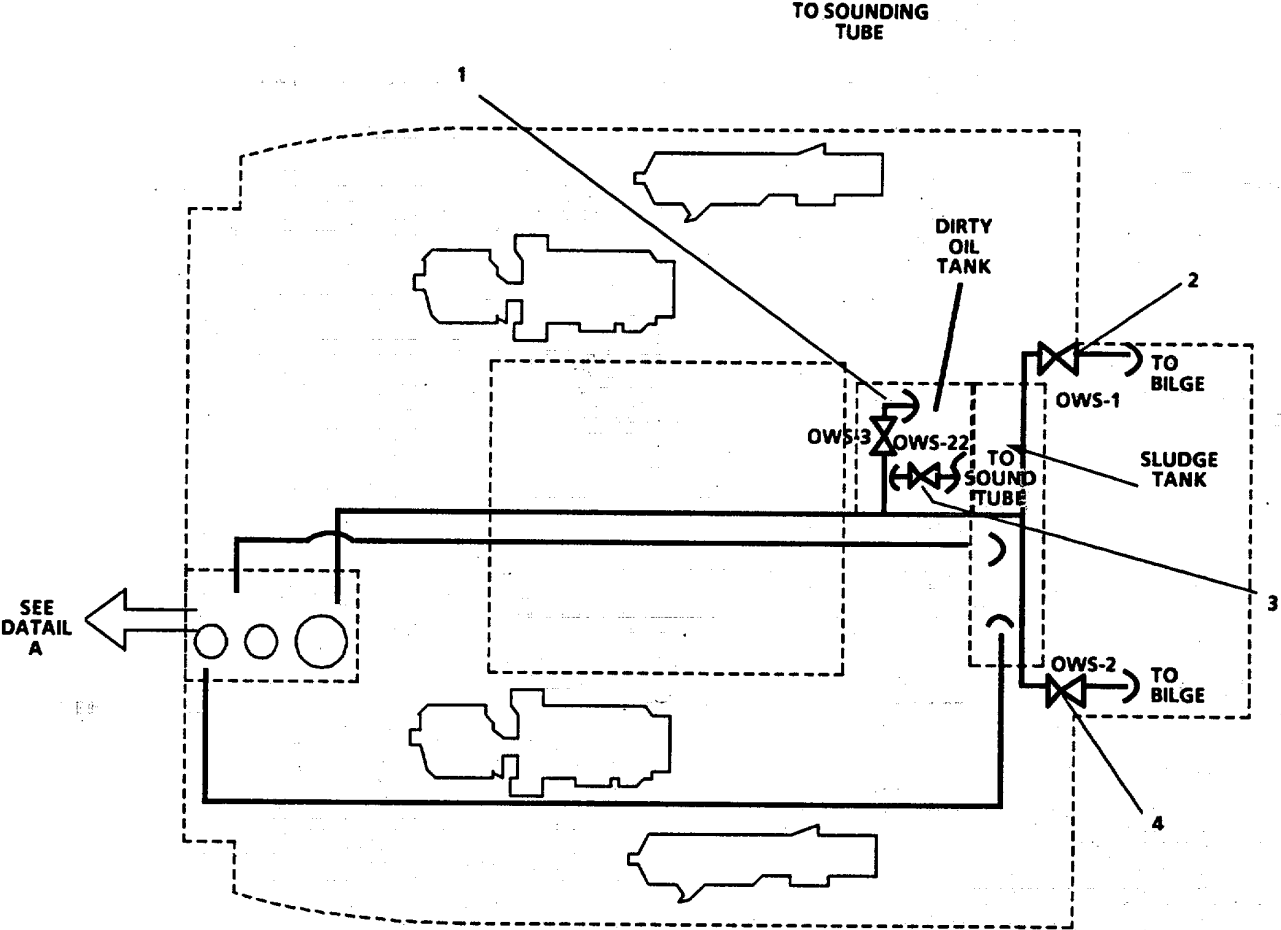

**LEGEND**

- 1. OWS-3, DIRTY OIL TK SUCT
- 2. OWS-1, BILGE SUCTION
- 3. OWS-22, SNDG TUBE DIRTY OIL TK
- 4. OWS-2, BILGE SUCTION

FIGURE 1-50. Oil-Water Separator Piping System (Sheet 1 of 5).

DETAIL A

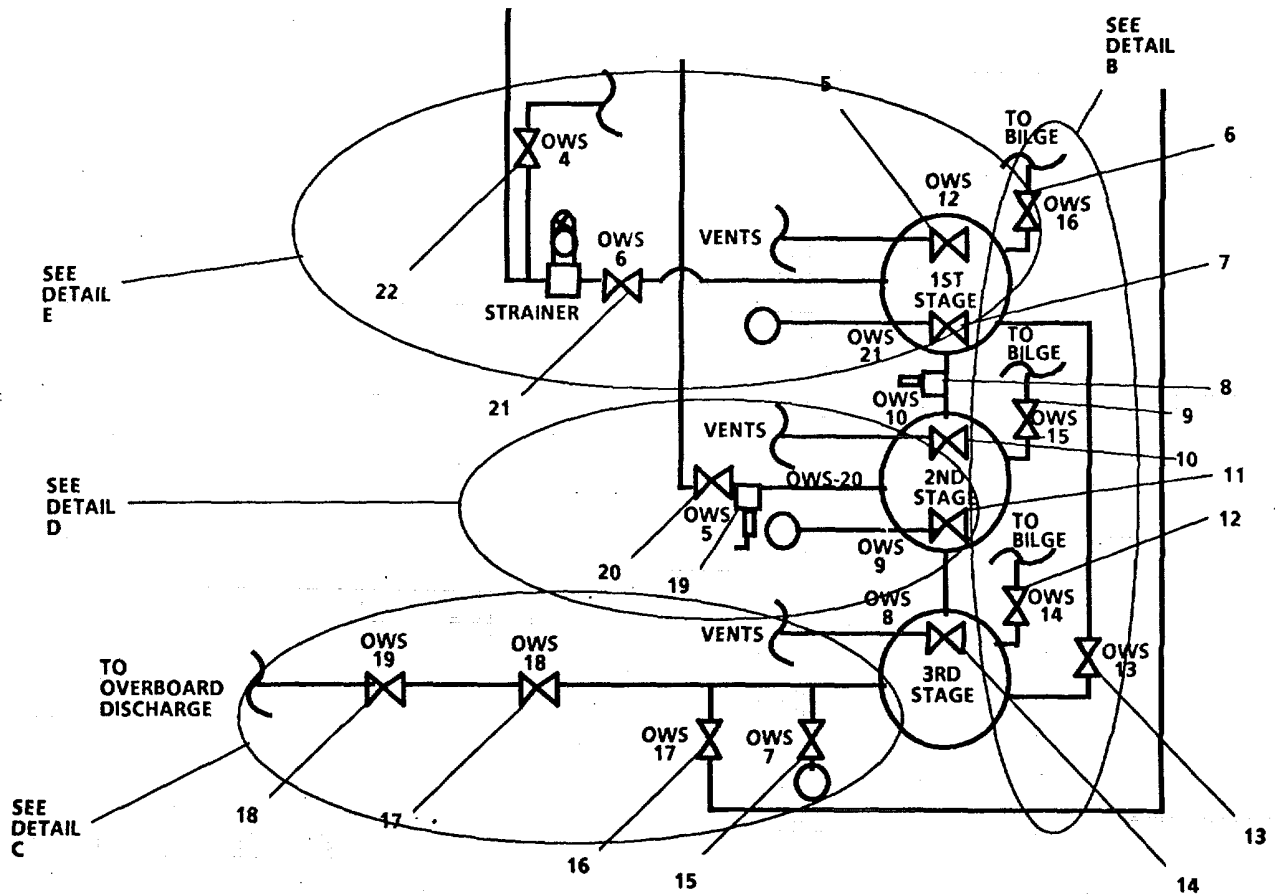

LEGEND

- |                                       |  |
|---------------------------------------|--|
| 5. OVS-12, 1ST STAGE VENT             | 14. OVS-8, 3RD STAGE VENT              |
| 6. OVS-16, 1ST STAGE DRAIN            | 15. OVS-7, 3RD STAGE PRESS GAGE        |
| 7. OVS-11, 1ST STAGE PRESS GAGE       | 16. OVS-17, RECIRC TO DIRTY OIL TK     |
| 8. OVS-21, RELIEF VALVE SET AT 36 PSI | 17. OVS-18, OVBD DISCH                 |
| 9. OVS-15, 2ND STAGE DRAIN            | 18. OVS-19, OVBD DISCH                 |
| 10. OVS-10, 2ND STAGE VENT            | 19. OVS-20, RELIEF VALVE SET AT 42 PSI |
| 11. OVS-9, 2ND STAGE PRESS GAGE       | 20. OVS-6, DISCH TO SLUDGE TK          |
| 12. OVS-14, 3RD STAGE DRAIN           | 21. OVS-5, 1ST STAGE SUCT              |
| 13. OVS-13, OIL RETURN TO 1ST STAGE   | 22. OVS-4, FRESH WATER MKUP            |

FIGURE 1-50. Oil-Water Separator Piping System (Sheet 2 of 5).

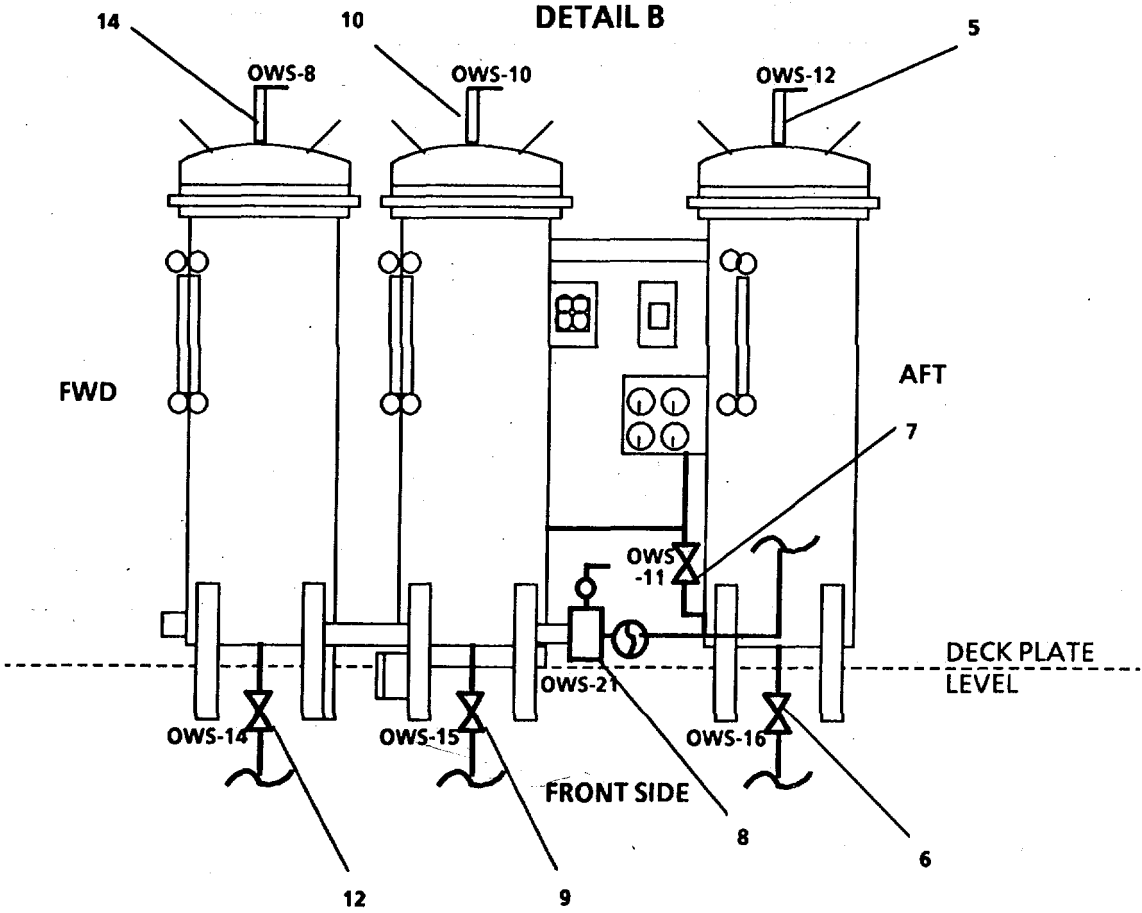

FIGURE 1-50. Oil-Water Separator Piping System (Sheet 3 of 5).



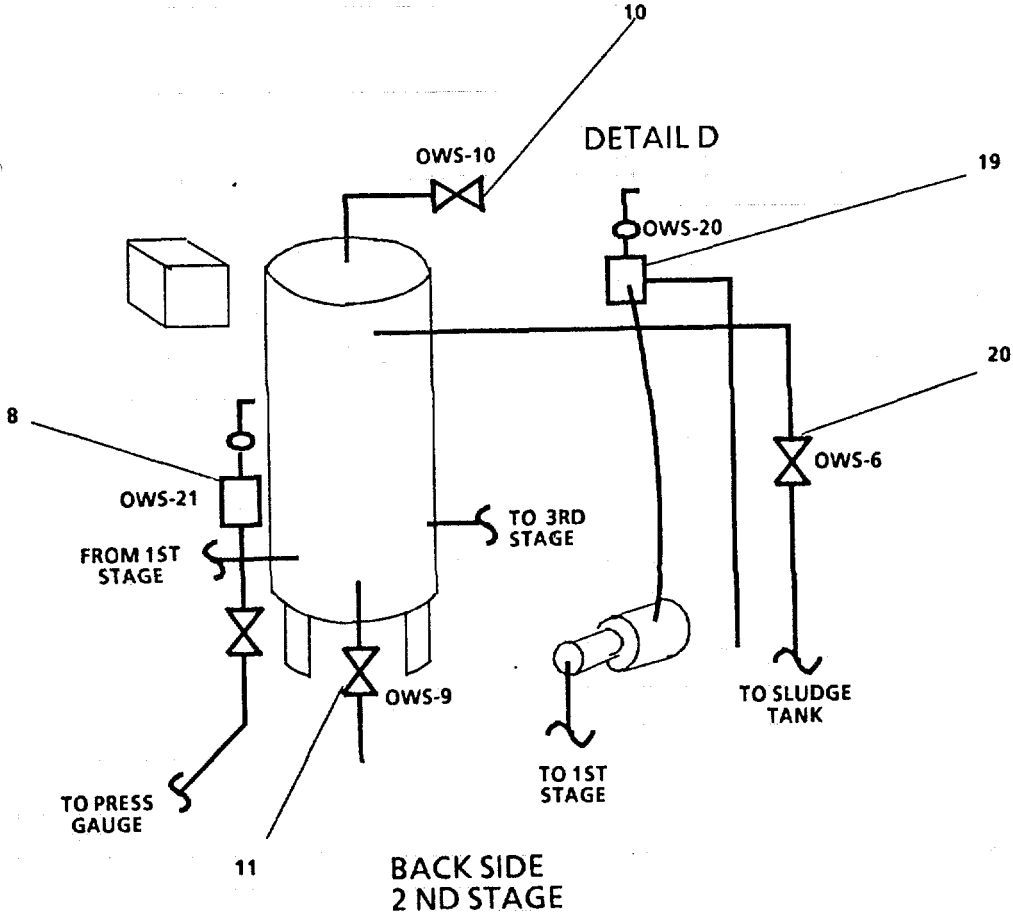
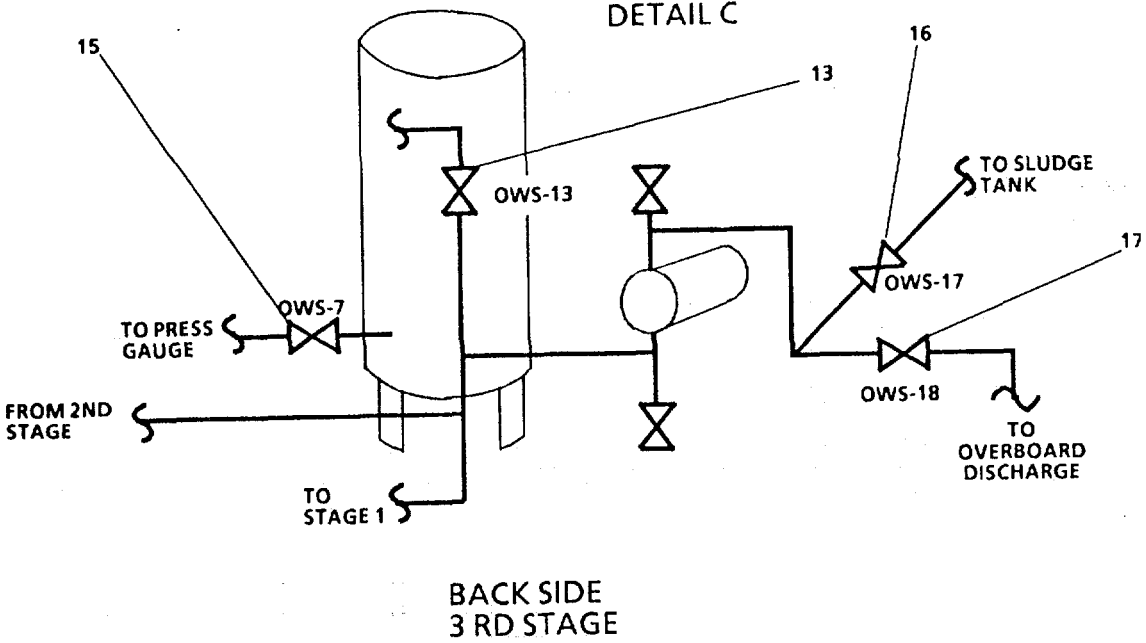
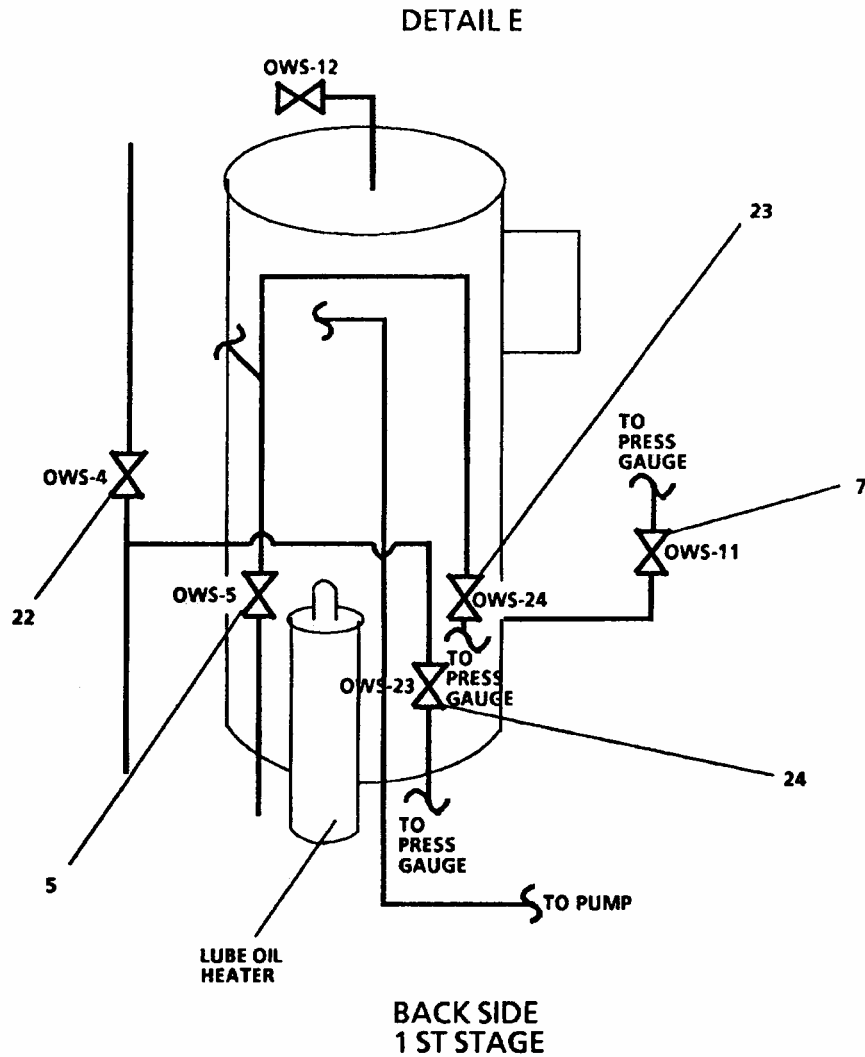

FIGURE 1-50. Oil-Water Separator Piping System (Sheet 4 of 5).



**LEGEND:**

- |   |   |
|---|---|
| 1. OWS-3, DIRTY OIL TK SUCT                 | 12. OWS-14, 3 <sup>RD</sup> STAGE DRAIN         |
| 2. OWS-1, BILGE SUCTION                     | 13. OWS-13, OIL RETURN TO 1 <sup>ST</sup> STAGE |
| 3. OWS-22, SNDG TUBE DIRTY OIL TK           | 14. OWS-8, 3 <sup>RD</sup> STAGE VENT           |
| 4. OWS-2, BILGE SUCTION                     | 15. OWS-7, 3 <sup>RD</sup> STAGE PRESS GAGE     |
| 5. OWS-12, 1 <sup>ST</sup> STAGE VENT       | 16. OWS-17, RECIRC TO DIRTY OIL TK              |
| 6. OWS-16, 1 <sup>ST</sup> STAGE DRAIN      | 17. OWS-18, OVBD DISCH                          |
| 7. OWS-11, 1 <sup>ST</sup> STAGE PRESS GAGE | 18. OWS-19, OVBD DISCH                          |
| 8. OWS-21, RELIEF VALVE SET AT 36 PSI       | 19. OWS-20, RELIEF VALVE SET AT 42 PSI          |
| 9. OWS-15, 2 <sup>ND</sup> STAGE DRAIN      | 20. OWS-6, DISCH TO SLUDGE TK                   |
| 10. OWS-10, 2 <sup>ND</sup> STAGE VENT      | 21. OWS-5, 1 <sup>ST</sup> STAGE SUCT           |
| 11. OWS-9, 2 <sup>ND</sup> STAGE PRESS GAGE | 22. OWS-4, FRESH WATER MKUP                     |

FIGURE 1-50. Oil-Water Separator Piping System (Sheet 5 of 5).

**1-44. Doors, Hatches and Scuttles.** Doors, hatches and scuttles provide access to spaces of either privacy, security or watertight/firetight integrity. Interior doors primarily provide access between above main deck interior spaces where security or watertight integrity is not a concern. Watertight doors provide access to interior spaces from weather spaces and to compartments where watertight integrity is a requirement. Hatches provide access to below main deck areas. Hatches offer watertight integrity when closed and dogged. When open, hatches allow transfer of equipment and personnel between decks. Scuttles provide emergency or restricted access to below deck engineering spaces. Dogged watertight doors are fitted to the bulkheads at each end of the tunnel. Flush access hatches are used on the cargo deck.

**1-45. Workboats/Liferafts.** The workboat functions as the utility small craft for operations such as sea rescue and personnel transport. The rigid, inflatable workboat has a 40-horsepower outboard motor. It is deployed and retrieved with an electrical winch crane. The electrical winch operates off ship's power at 230 VAC, three-phase, 60 Hz. The unit is capable of 360° noncontinuous rotation. A hand crank is provided for manual slewing. The liferafts are designed for compact storage aboard ship and for quick inflation when necessary to abandon ship or for use in other emergencies. The liferaft is inflated by pulling on the "Automatic Painter". The liferaft release mechanism will automatically actuate if the ship sinks, due to pressure at 15 to 20 feet. The container is inherently buoyant and floats to the surface.

**1-46. Airports, Fixed Lights and Windows.** All glass onboard the LCU is heat treated and readily replaceable aboard ship. All windows, airports, fixed lights in exterior doors, glass doors and panels (except pilothouse windows which cause light to reflect on the structure) are provided with deadlight covers, light excluding shades, lined drapes or other devices. Removable insert screens are provided for all air ports. Screens are designed to insert into the air ports from outside and fit air port dogs. The complete assembly is readily removable from the air port. Pilothouse front windows are slanted inward at the bottom for protection against glare.

**1-47. Description of FM-200.** FM-200 (1,1,1,2,3,3,3) Heptafluoropropane is a compound of Carbon, Fluorine and Hydrogen ( $\text{CF}_3\text{CHF}_2\text{CF}_3$ ). It is colorless, odorless, and electrically non-conductive. It suppresses fire by a combination of chemical and physical mechanisms without affecting the available oxygen. FM-200 is clean, leaves no residue, thereby eliminating costly after-fire clean-up, and keeping "down time" to a minimum. FM-200 is stored in steel containers, at 360 PSIG, 70°F (25 bars at 21°C), as a liquid, with Nitrogen added to improve the discharge characteristics. When discharged, the FM-200 liquid vaporizes at the discharge nozzles and is uniformly distributed as it enters the fire area. FM-200 is approved for total flooding fire extinguishing applications in occupied spaces by the Environmental Protection Agency (EPA) and appears on the Significant New Alternatives Policy (SNAP) list of acceptable substitutes for ozone depleting substances. FM-200 is also on the clean halocarbon fire extinguishing agents listed in the National Fire Protection Agency (NFPA) 2001 Standard, Clean Agent Fire Extinguishing Systems and is approved for marine application by the US Coast Guard (USCG).

The FM-200 Total Flooding Fire Extinguishing Systems on LCU-2K consists of five (5) manually actuated systems.

a. Engine Room. This manually actuated system is designed and installed to protect the Engine Room and bilge (3-25-0-E), Frames 25 to 44. The physical location of this system, less FM-200 distribution piping and nozzles, Electric Horn/Strobe, and Warning Lights (Amber Strobe), is installed outside of the protected space. Two (2) each 600 pound cylinders and supporting components, installed on the forward bulkhead, Frame 42 1/2, A/C and Emergency Generator Room (1-43-0-E), provide protection for the Engine Room and bilge. One (1) each 350 pound cylinder and supporting components, installed on the 7'0" off centerline longitudinal bulkhead, Starboard side, Frames 23 to 24, Tunnel (3-17-0-Q), provide protection for the Forward Engine Room (MCC/Storeroom/Machine shop areas) and bilges.

b. Tunnel. This manually actuated system is designed and installed to protect the Tunnel and bilge (3-17-0-Q), Frame 17 to 25. The physical location of this system, less FM-200 distribution piping and nozzles, Electric Horn/Strobe, and Warning Light (Amber Strobe), is installed outside of the protected space. One (1) each 350 pound FM-200 cylinder and supporting components, installed on the 7'0" off centerline longitudinal bulkhead, Port side, Frames 26 to 27, Engine Room (3-25-0-E), provide protection for the Tunnel and bilge.

c. Bow Thruster Room. This manually actuated system is designed and installed to protect the Bow Thruster Room and bilge (3-5-0-E), Frames 5 to 17. The physical location of this system, less FM-200 distribution piping and nozzles, Electric Horn/Strobe, and Warning Light (Amber Strobe), is installed outside of the protected space. One (1) each 350 pound FM-200 cylinder and supporting components, installed on the 7'0" off centerline longitudinal bulkhead, Port side, Frames 19 to 20, Tunnel (3-17-0-Q), provides protection for Bow Thruster Room and bilge.

d. Paint Locker. This manually actuated system is designed and installed to protect the Paint Locker (1-0-2-Q), Frames 0 to 13. The physical location of this system, less FM-200 distribution piping and nozzle and FM-200 Siren, is installed outside the protected space. One (1) each 125 pound FM-200 cylinder and supporting components, installed on the 7'0" off centerline longitudinal bulkhead, Port side, Frame 10, Bow Thruster Room (3-5-0-E), provide protection for the Paint Locker.

e. A/C and Emergency Generator Room. This manually activated system is designed and installed to protect the A/C and Emergency Generator Room (1-43-0-E), Frames 42 1/2 to 52. The physical location of this system, less FM-200 distribution piping and nozzles, Electric Horn/Strobe, and Warning Light (Amber Strobe), is installed outside of the protected space. One (1) each 125 pound FM-200 cylinder and supporting components, installed in the Stowage Locker (1-43-1-Q), Frames 43 to 44, provides protection for A/C and Emergency Generator Room.

**1-48. Water Washdown System (WWS).** The WWS built of all stainless components are three (3) separate systems installed in the Engine Room, Tunnel, and Bow Thruster Room. The WWS is a hydrogen fluoride (HF) gas mitigation, water washdown system (WWS) which provides general overhead coverage to the protected spaces. The WWS is a simple overhead sprinkler grid which is piped directly to the existing firemain. It receives seawater from the Bow Thruster Emergency Fire Pump (Engine Room WWS) and two (2) Engine Room Fire Pumps (Bow Thruster Room and Tunnel WWS). The Bow Thruster Emergency Fire Pump is powered by the Bow Thruster diesel engine and the two (2) Engine Room Fire Pumps are powered electrically from the Ships Service Switchboard 240 V Distribution Panel.

The WWS, upon activation, serves to:

- Quickly reduce the temperature within the protected space.
- Minimize production of Hydrogen Fluoride (HF) Gas which is produced as a result of FM-200 agent decomposition in contact with hot surfaces and flame at temperatures above 1300°F.
- Aid in scrubbing of any HF Gas generated.
- Expedite ventilation of the protected space.



CHAPTER 2  
OPERATING INSTRUCTIONS

	<u>Page</u>
Section I. Description and Use of Operator's Controls and Indicators.....	2-1
Section II. Preventive Maintenance Checks and Services (PMCS).....	2-207
Section III. Operation Under Usual Conditions.....	2-283
Section IV. Operation Under Unusual Conditions.....	2-641

**Section I. DESCRIPTION AND USE OF OPERATOR'S CONTROLS AND INDICATORS**

<u>Compartment or Function/Figure Title</u>	<u>PAGE No.</u>
<b>Pilothouse</b>	
Pilothouse Console.....	2-1
Steering Control Panel.....	2-2
Autopilot Control Panel.....	2-3
Bowthruster Waterjet Control Panel.....	2-4
Engine Order Telegraph (EOT).....	2-5
Bow Ramp Control Panel.....	2-6
Bridge Console Panel.....	2-7
Gyro Compass Mark 27 Mod 1 Electronic Control Panel.....	2-8
Mark 37 Mod E Transmission Unit.....	2-9
Magnetic Compass.....	2-10
Standard Bearing Repeater.....	2-11
Open Scale Compass Repeater.....	2-12
500 Watt Xenon Searchlight.....	2-13
Automatic Power Switch.....	2-14
Navigation Light Panel.....	2-15
Marine Fire Detector Panel.....	2-16
Clearview Screen Control Panel.....	2-17
<b>Telephones/Intercom</b>	
Sound Powered Telephone, Model SER.....	2-18
Sound Powered Telephone, Model SELR.....	2-19
Sound Powered Telephone, Model SFLR.....	2-20
Sound Powered Telephone, Model MWT-R.....	2-21
Head Set-Chest Set, Sound Powered.....	2-22
Intercom Panel, LS-519A/SIC(U).....	2-23
<b>Engine Room Operating Station</b>	
Engine Room Console.....	2-24
Machinery Plant Monitor Panel.....	2-25
Engine Room Console Panel.....	2-26
Engine Efficiency Panel.....	2-27
Main Switchboard.....	2-28
<b>Engine Room</b>	
Auxiliary Machinery Motor Control Center.....	2-29
Engine Room Ventilation Motor Control Center.....	2-30

<u>Compartment or Function/Figure Title</u>	<u>PAGE No.</u>
Engine Room - continued	
Air Compressor and Gauges.....	2-31
Main Engine Control Panel.....	2-32
Ships Service Diesel Generator.....	2-33
Tank Level Indicators.....	2-34
Oil-Water Separator.....	2-35
Reverse Osmosis Desalinator.....	2-36
Fresh Water Motor Controller.....	2-37
Fuel Oil Transfer Pump Motor Controller.....	2-38
Lube Oil Purifier.....	2-39
Marine Sanitation Device.....	2-40
Steering Gear Compartment	
Steering Gear Motor Controller.....	2-41
Steering Gear Room Local Control Unit.....	2-42
Air Conditioner and Emergency Generator Room.....	
Emergency Switchboard.....	2-43
Emergency Generator Diesel Engine Control Panel.....	2-44
15 Ton A/C Controller.....	2-45
Bowthruster Waterjet.....	2-46
Bowthruster Engine Control Panel.....	2-47
Ramp and Anchors Controls	
Stern Anchor Winch Controls.....	2-48
Bow Anchor Windlass.....	2-49
Bow Ramp System.....	2-50
Bow Ramp Locking Assembly.....	2-51
Tunnel	
Forward Deck Machinery Motor Control Center.....	2-52
Fire Fighting and Safety	
Surface Pull Box HALON 1301 Fire Suppression System.....	2-53
Lever Operated Control HALON 1301 Fire Suppression System.....	2-54
Remote Lever Operated Control HALON 1301 Fire Suppression System.....	2-55
Pneumatic Switch HALON 1301 Fire Suppression System.....	2-56
Fire Station.....	2-57
Oxygen Breathing Apparatus (OBA).....	2-58
Portable Fire Pump (P-250).....	2-59
Liferaft.....	2-60
Rescue/Workboat and Motor.....	2-61
Rescue/Workboat Crane.....	2-62
Machine Shop	
Bench Grinder.....	2-63
Electric Welding Machine.....	2-64
Laundry	
Clothes Dryer Panel.....	2-65
Clothes Washer Panel.....	2-66
Galley	
Dishwasher.....	2-67
Electric Griddle.....	2-68
Marine Electric Range.....	2-69
Gaylord Hood Controls.....	2-70
Meat Slicer.....	2-71
Microwave Oven Panel.....	2-72

<u>Compartment or Function/Figure Title</u>	<u>PAGE No.</u>
Galley - continued	
Electric Mixer .....	2-73
Milk Dispenser.....	2-74
Post-Mix Dispenser .....	2-75
Marine Coffee Maker, OT-20 .....	2-76
Trash Compactor.....	2-77
Freezer, Model F30-2M-ADS.....	2-78
Freezer, Model F20-2M-ADS.....	2-79
Refrigerator, Model R30-2M-S.....	2-80
Refrigerator, Model R18-2M-S.....	2-81
Fry Kettle .....	2-82
Ice Maker .....	2-83
Electrical Controls and Panels	
Type I Motor Switch.....	2-84
Type II Motor Controller .....	2-85
Power and Lighting Distribution Panels.....	2-86

2-1. **General.** Operator's controls and indicators are functionally explained in Table 2-1. Each control and indicator for the LCU is listed. An associated illustration is given with callouts corresponding to the item number in Table 2-1. The control or indicator is described from the point of view of the operator. Names of items called out in the table correspond to labels that are located on the actual equipment. Where practical, the exact words or numbers located on the gauge, dial, button or switch are illustrated to assist the operator in locating and properly operating the equipment or system. However, the operator should understand that a vessel's life cycle is quite lengthy and replacement controls or indicators may vary slightly from those originally installed or described herein. The FUNCTION column of this table does not describe readings that an operator is likely to encounter. Instead, brief functions of the control or indicator are addressed.

a. Table Arrangement. Table 2-1 is laid out in a space by space arrangement in the following order: (1) Pilothouse, (2) Telephones/Intercom, (3) Engine Room Operating Station, (4) Steering Gear Compartment, (5) Air Conditioner and Emergency Generator Room, (6) Bowthruster Room, (7) Ramp and Anchors Controls, (8) Tunnel, (9) Fire Fighting and Safety, (10) Machine Shop, (11) Laundry, (12) Galley, (13) Electrical Controls and Panel. Power distribution and power panels are discussed last in order to assist the operator in easily locating all power panels in order to perform the PMCS and Operating Procedures that follow Table 2-1.

b. Locating Controls and Indicators. There are two methods to locate a particular control or indicator: (1) Go to the section table of contents, find the section of the index for the compartment where the control or indicator is located. The specific piece of equipment and the associated figure number will be listed. Figures and associated tabular information are located together, (2) Go to the alphabetical index located at the back of this manual. The specific piece of equipment will be listed there and subordinate headings for controls and indicators will list the figure number for that specific piece of equipment. Figures and associated tabular information are located together.



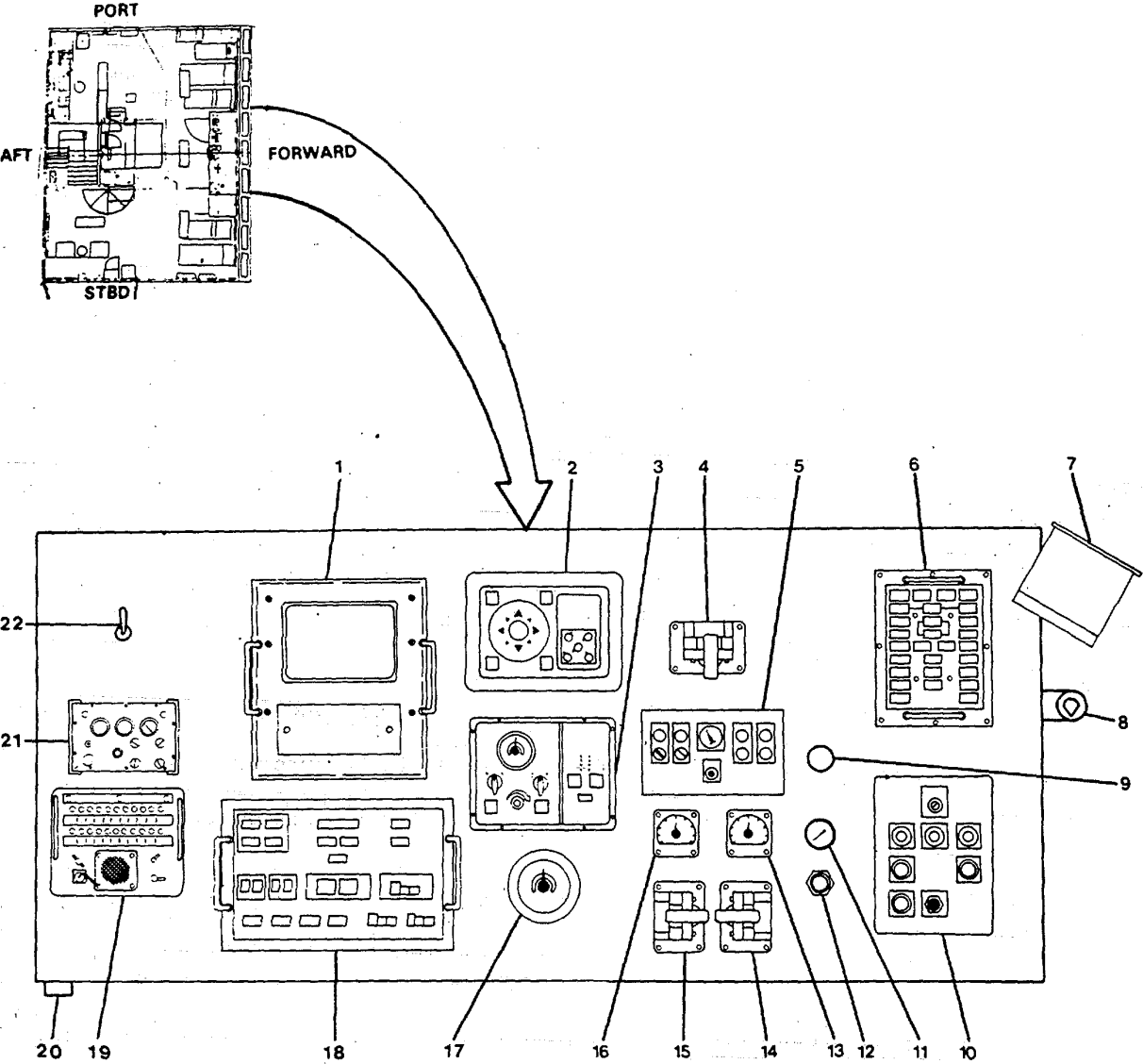

FIGURE 2-1. Pilothouse Console.

Table 2-1. Description of Operator's Controls and Indicators - CONT

Key	Control or Indicator	Function
Pilothouse Console (FIGURE 2-1)		
1	CRT-MCHRY SYSTEMS MONITOR	Displays information for the main propulsion power train, selected pumps, ship's service diesel generators, and vital alarms. For more information, see paragraph 1-13.
2	AUTOPILOT CONTROL	Provides control of vessel autopilot system.
3	STEERING CONTROL	Provides control of vessel steering system.
4	Bowthruster/Emergency Fire Pump Throttle Control	Provides control of bowthruster engine speed.
5	BOWTHRUSTER CONTROL	Provides directional control of bowthruster waterjet.
6	ENGINE ORDER TELEGRAPH	Indicates desired speed and directional signals to the engine room.
7	Depth Finder Digital Display	Indicates depth of water in feet or fathoms.
8	BLINKER LIGHT KEY	Controls signal to the blinker lights.
9	BOWTHRUSTER ENG RPM	Indicates bowthruster engine rpm.
10	BOW RAMP CONTROL	Provides control to raise and lower the bow ramp.
11	THROTTLE AIR PRESS	Indicates control air pressure in psi.
12	CONTROL AIR STA TRANSFER VALVE	Acknowledges control air transfer from EOS to pilothouse.
13	TACH-STBD SHAFT	Indicates shaft RPM of starboard main engine.
14	THROTTLE-STBD ENG	Controls speed of starboard main engine and direction of starboard shaft.
15	THROTTLE-PORT ENG	Controls speed of port main engine and direction of port shaft.
16	TACH-PORT SHAFT	Indicates shaft RPM of port main engine.

Table 2-1. Description of Operator's Controls and Indicators - CONT

Key	Control or Indicator	Function
Pilothouse Console (FIGURE 2-1) - Continued		
17	RUDDER ANGLE INDICATOR	Indicates rudder position relative to center-line of vessel.
18	BRIDGE CONSOLE PANEL	Provides control of CRT-MCHRY systems monitor, firepumps, and start-stop control of bowthruster engine.
19	INTERCOM UNIT	Provides station-to-station shipboard communications.
20	GENERAL ALARM CONTACT MAKER	Activates general alarm.
21	URC-80	Provides non-tactical external radio communication.
22	URC-80 POWER SW	ON-OFF power switch for URC-80 operation.

This page intentionally left blank.

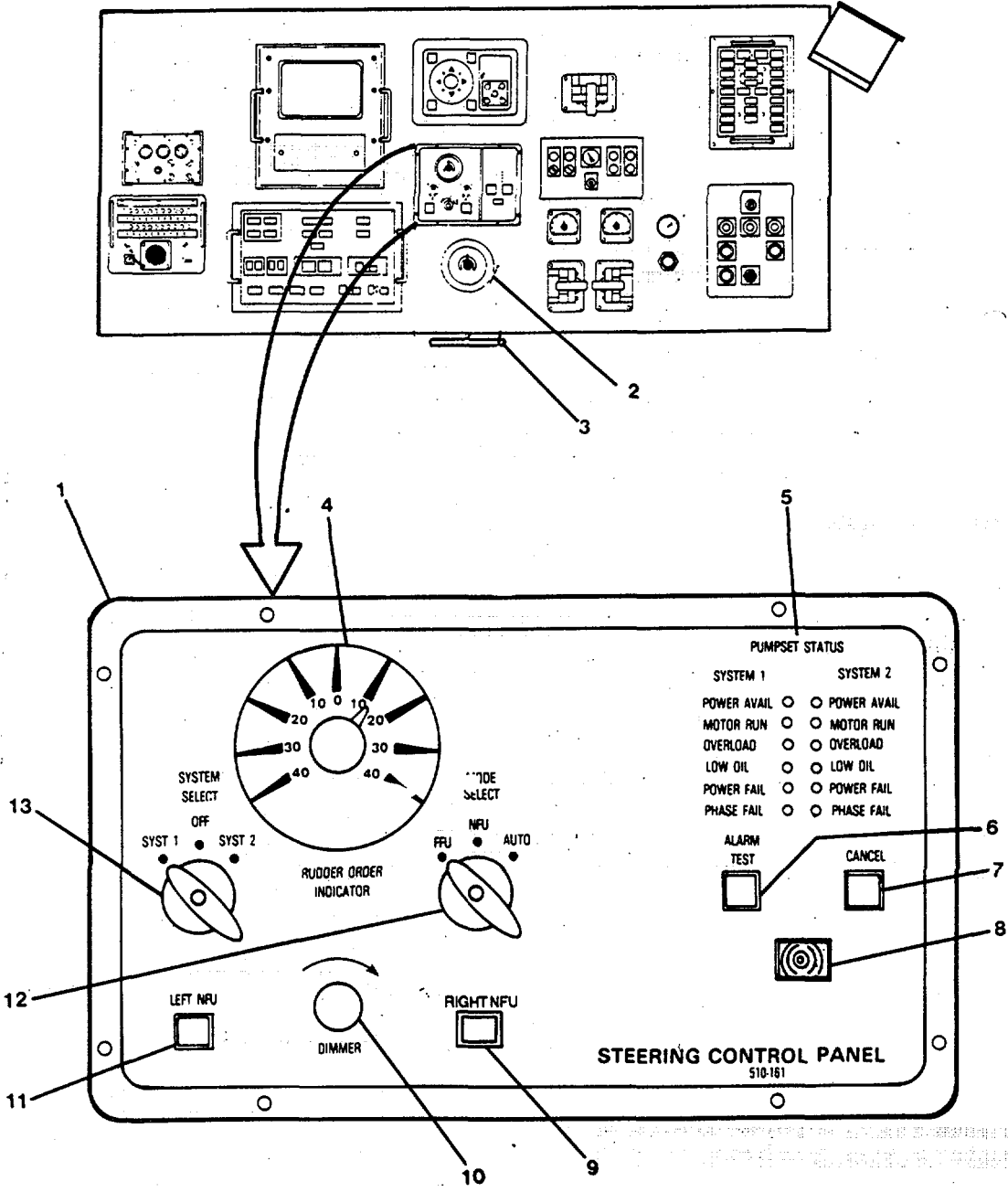

FIGURE 2-2. Steering Control Panel.

Table 2-1. Description of Operator's Controls and Indicators

Key	Control or Indicator	Function
Steering Control Panel (FIGURE 2-2)		
1	STEERING CONTROL PANEL	Provides steering system controls.
2	Rudder Angle Indicator	Indicates position of rudder in relation to centerline of ship.
3	Helm	Turning helm causes rudder directional change proportional to and in the same direction as helm travel.
4	RUDDER ORDER INDICATOR	Indicates ordered position of rudder.
5	PUMPSET STATUS	Indicates which system is providing power and the status of the system as follows:  <ul style="list-style-type: none"> <li>- POWER AVAIL</li> <li>- MOTOR RUN</li> <li>- OVERLOAD</li> <li>- LOW OIL</li> <li>- POWER FAIL</li> <li>- PHASE FAIL</li> </ul>
6	ALARM TEST	Provides a push to test alarm for the pumpset status.
7	CANCEL	Pushbutton to acknowledge and silence alarm from pumpset system.
8	Alarm Signal	Sounds to indicate fault in either pumpset.
9	RIGHT NFU	Pushbutton:  <ul style="list-style-type: none"> <li>a. FFU or AUTO Mode. Green button moves rudder to right when depressed. When released, rudder returns to position previously commanded by helm or autopilot.</li> <li>b. NFU Mode. Green button moves rudder to right. When released, rudder remains stationary at the position commanded.</li> </ul>
10	DIMMER	Controls light intensity.

Table 2-1. Description of Operator's Controls and Indicators - CONT

Key	Control or Indicator	Function
Steering Control Panel (FIGURE 2-2)		
11	LEFT NFU	Pushbutton: a. FFU or AUTO Mode. Red button moves rudder to left when depressed. When released, rudder returns to position previously commanded by helm or autopilot. b. NFU Mode. Red button moves rudder to left when depressed. When released, rudder remains stationary at the position commanded.
12	MODE SELECT	Selects FFU (Full-Followup), NFU (Non-Followup), or AUTO (Autopilot) operating modes.
13	SYSTEM SELECT	Selects either pumpset System 1 or pumpset System 2. When in OFF position, both pumpsets power is turned OFF.

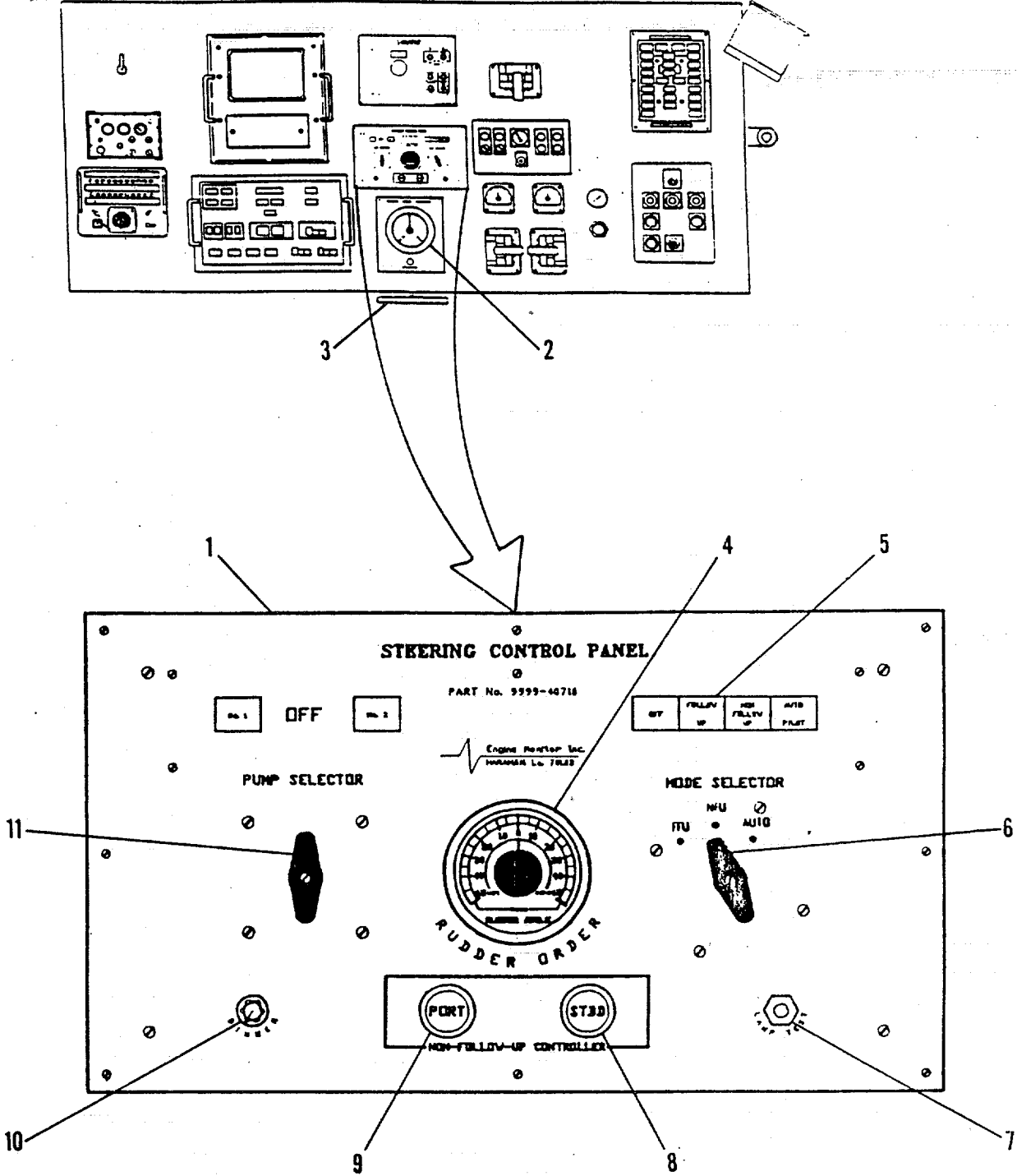

FIGURE 2-2.1. Steering Control Panel.

Change 2 (2-11 blank)/2-12



Table 2-1. Description of Operator's Controls and Indicators

Key	Control or Indicator	Function
Steering Control Panel (FIGURE 2-2.1) Hulls 2008 and subsequent		
1	STEERING CONTROL PANEL	Provides steering system controls.
2	Rudder Angle Indicator	Indicates position of rudder in relation to centerline of ship.
3	Helm	Turning helm causes rudder directional change proportional to and in the same direction as helm travel.
4	RUDDER ORDER INDICATOR	Indicates ordered position of rudder.
5	Status Indicators	Indicates which system is providing power and the status of the system.
6	MODE SELECTOR	Selects FFU (Full-Follow-up), NFU (Non-Follow-up), or AUTO (Autopilot) operating modes.
7	LAMP TEST	Tests operation of status indicators.
8	STBD Non-Follow-up	Green STBD Non-Follow-up Control.
9	PORT Non-Follow-up	Red Port Non-Follow-up Control
10	DIMMER	Controls light intensity.
11	PUMP SELECTOR	Selects either pumpset System 1 or pumpset System 2. When in OFF position, both pumpsets power is turned OFF.

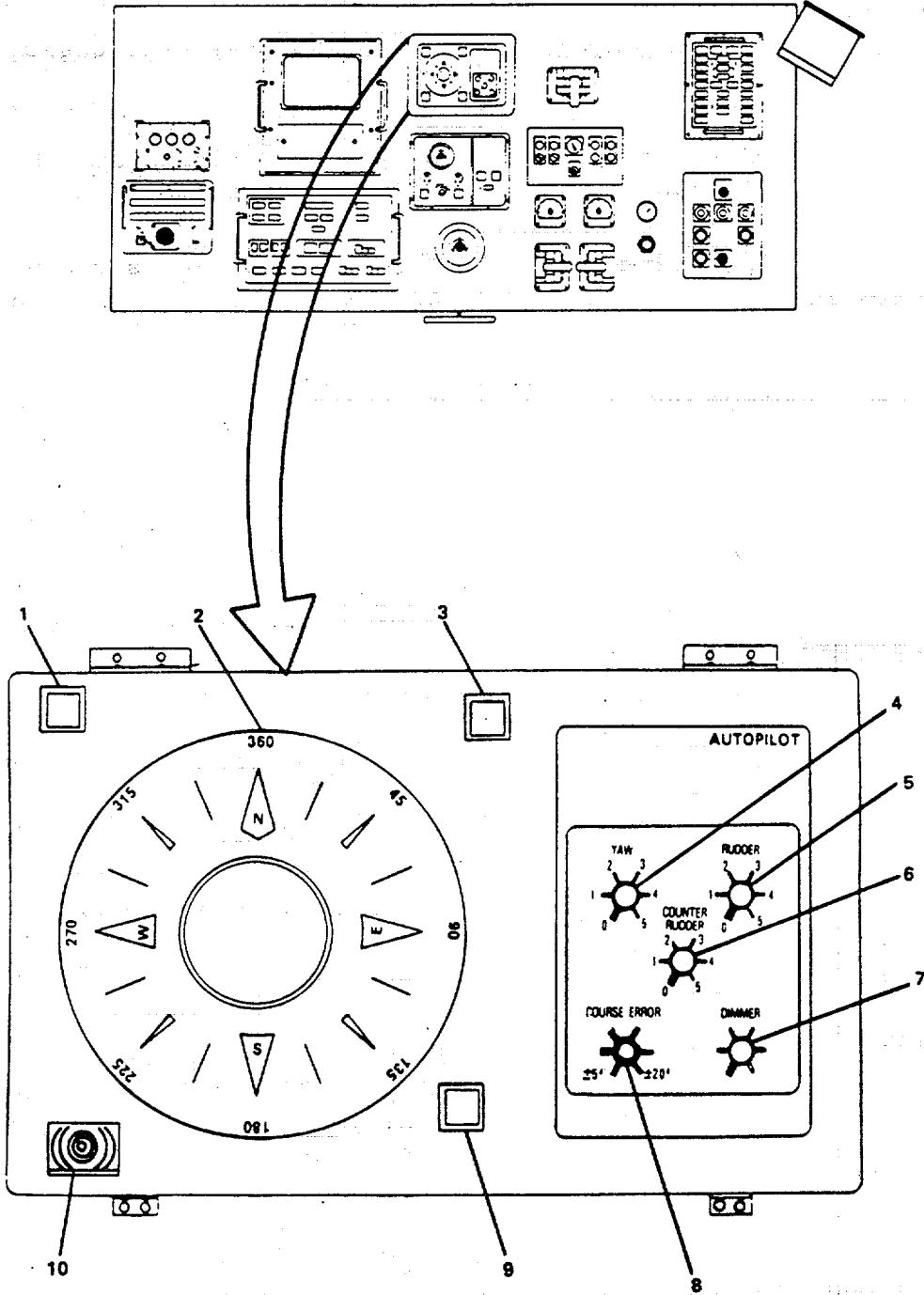
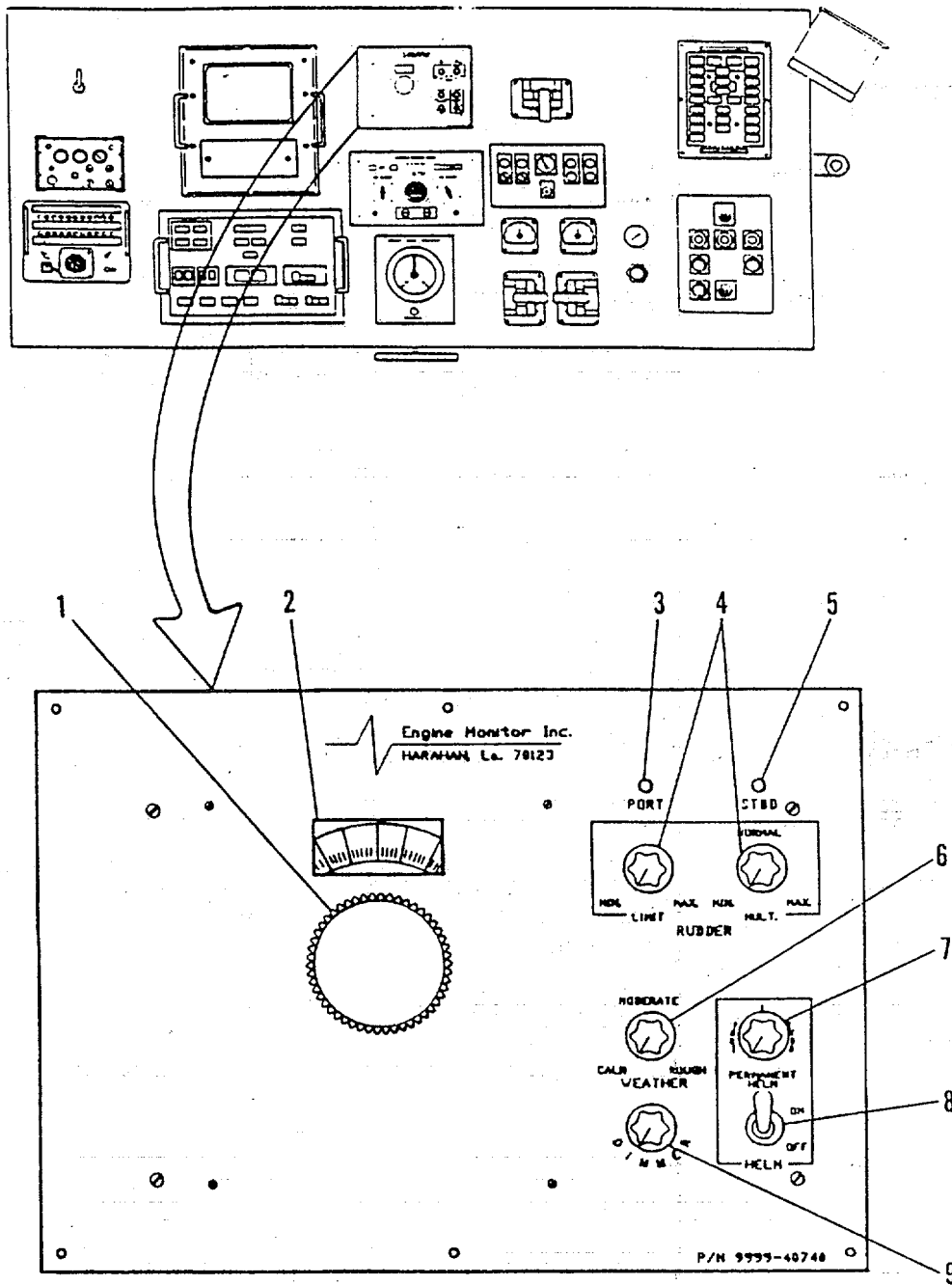

FIGURE 2-3. Autopilot Control Panel.

Change 2 2-12.2

Table 2-1. Description of Operator's Controls and Indicators - CONT

Key	Control or Indicator	Function
Autopilot Control Panel (FIGURE 2-3)		
1	Course Change	Pushbutton (red) turns ship to port until desired compass heading on dial comes around to the Lubber Line.
2	Combination Repeater	Provides compass reading.
3	Course Change	Pushbutton (green) turns ship to starboard until desired compass heading on dial comes around to the Lubber Line.
4	YAW	Adjusts allowed deviation from ordered course of the autopilot.
5	RUDDER	Varies the amount of rudder applied for a given course error.
6	COUNTER RUDDER	Checks amount of rudder applied dependent on the rate of change of course error.
7	DIMMER	Varies illumination of dial.
8	COURSE ERROR	Adjusts autopilot for course error.
9	Alarm Silence	Pushbutton silences course alarm warning horn. Light is extinguished by returning vessel to set course.
10	Alarm Signal	Sounds to indicate fault in autopilot.



Hulls 2008 and subsequent

FIGURE 2-3.1. Autopilot Control Panel.

Change 2 2-14

Table 2-1. Description of Operator's Controls and Indicators

Key	Control or Indicator	Function
Autopilot Control Panel (FIGURE 2-3.1) Hulls 2008 and subsequent		
1	Course Change	Turns ship to port or stbd. to desired compass heading.
2	Indicator	Provides heading reading.
3	Port L.E.D.	Lights when turning to port.
4	RUDDER	Varies the amount of rudder applied for a given course error.
5	STBD. L.E.D.	Lights when turning to starboard.
6	WEATHER	Adjust for calm to rough seas.
7	PERMANENT HELM	Adjust permanent helm when helm switch is on.
8	HELM	Turns permanent helm ON or OFF.
9	DIMMER	Varies illumination of dial.

Change 2 2-14.1

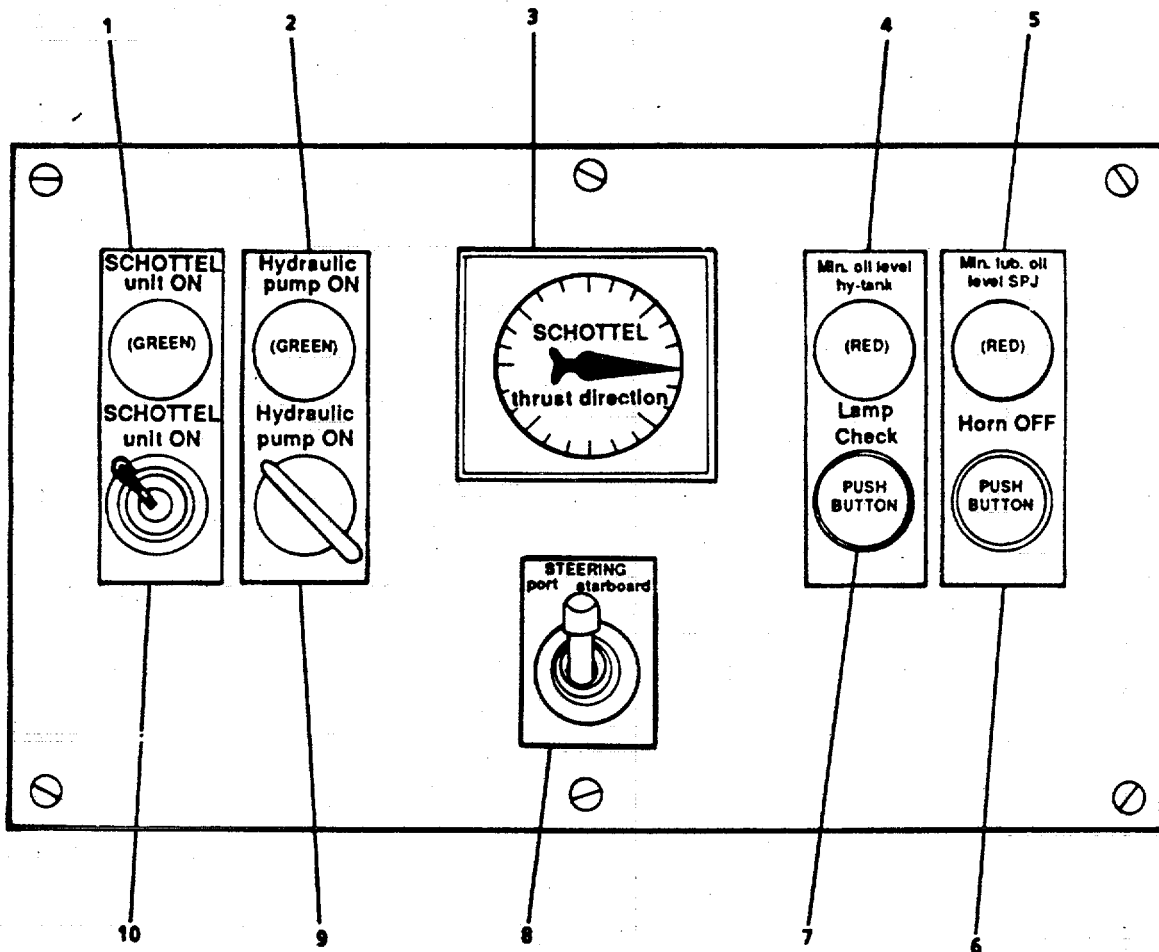

- LEGEND**
- 1. SCHOTTEL UNIT ON
  - 2. THRUST DIRECTION INDICATOR
  - 3. STEERING CONTROL JOYSTICK
  - 4. HYDRAULIC PUMP SWITCH

FIGURE 2-4. Bowthruster Waterjet Control Panel.

Table 2-1. Description of Operator's Controls and Indicators - CONT

Key	Control or Indicator	Function
Bowthruster Waterjet Control Panel (FIGURE 2-4)		
1	SCHOTTEL unit ON	Indicates waterjet power unit is powered (green).
2	HYDRAULIC pump ON	Indicates waterjet hydraulic unit is on (green).
3	Thrust Direction	Indicates direction of jet nozzle.
4	Min oil level hy-tank	Indicates low oil level in hydraulic oil tank (red). Alarm horn will sound.
5	Min lub oil level SPJ	Indicates low lubricating oil level in lube oil tank (red). Alarm horn will sound.
6	Horn OFF	Pushbutton silences audible warning device for both hydraulic oil and lube oil.
7	Lamp Check	Pushbutton provides lamp check of control console indicator lights.
8	STEERING port starboard	Joystick controls waterjet direction clockwise or counterclockwise.
9	HYDRAULIC pump ON	Controls ON-OFF operation of waterjet hydraulic system.
10	SCHOTTEL unit ON	Key switch controls ON-OFF operation of waterjet electrical power unit.

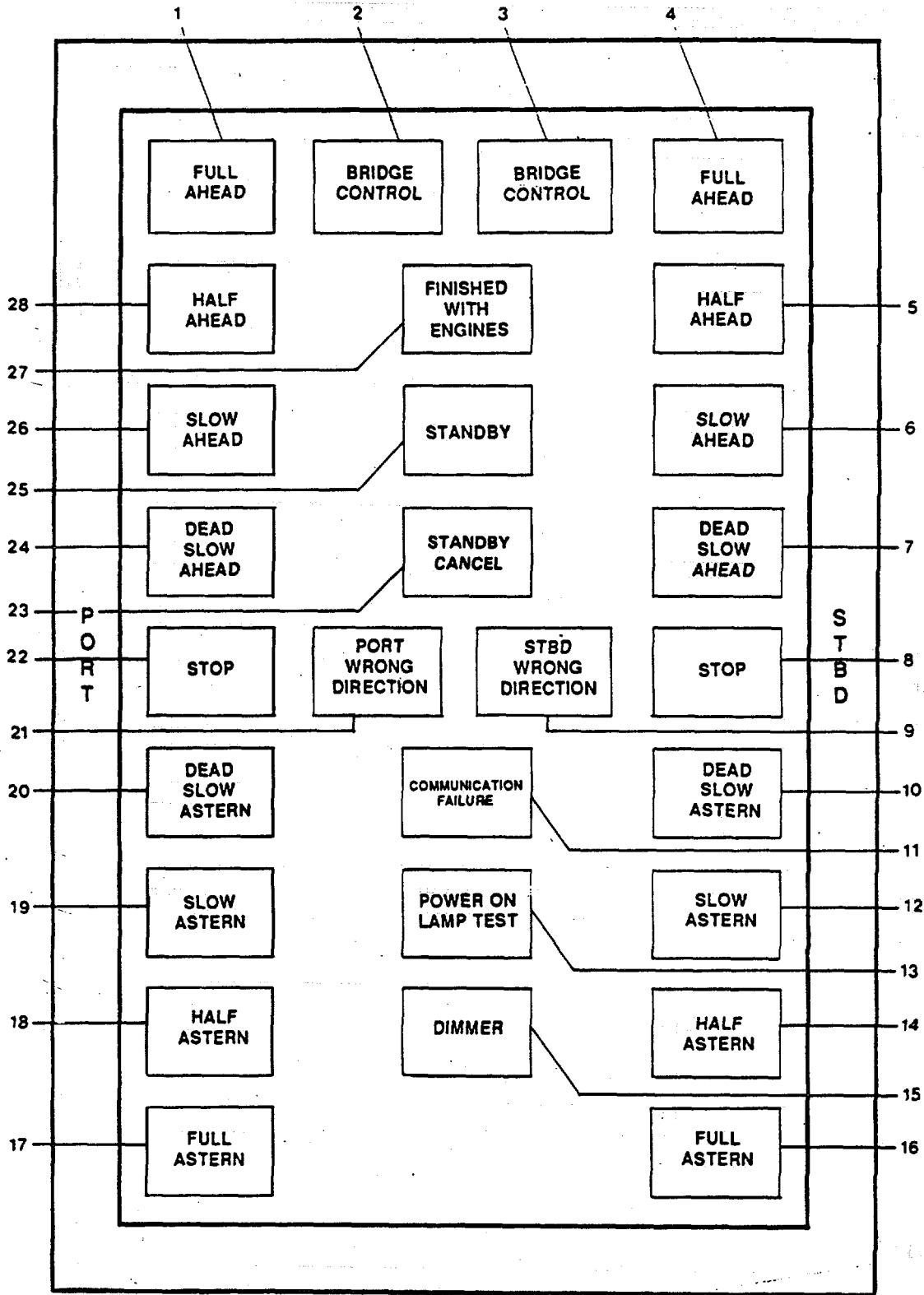

FIGURE 2-5. Engine Order Telegraph (EOT).



Table 2-1. Description of Operator's Controls and Indicators - CONT

Key	Control or Indicator	Function
Engine Order Telegraph (EOT) (FIGURE 2-5)		
1	FULL AHEAD	Indicates order for port engine full speed ahead (green).
2	BRIDGE CONTROL	Indicates pilothouse control of port engine speed and direction (white).
3	BRIDGE CONTROL	Indicates pilothouse control of starboard engine speed and direction (white).
4	FULL AHEAD	Indicates order for starboard engine full speed ahead (green).
5	HALF AHEAD	Indicates order for starboard engine half speed ahead (green).
6	SLOW AHEAD	Indicates order for starboard engine slow speed ahead (green).
7	DEAD SLOW AHEAD	Indicates order for starboard engine dead slow speed ahead (green).
8	STOP	Indicates order to STOP starboard engine (red).
9	STBD WRONG DIRECTION	Indicates starboard engine wrong order given at EOS (red).
10	DEAD SLOW ASTERN	Indicates order for starboard engine dead slow speed astern (yellow).
11	COMMUNICATION FAILURE	Indicates a power failure in-EOT system (red).
12	SLOW ASTERN	Indicates order for starboard engine slow speed astern (yellow).
13	POWER ON LAMP TEST	Indicates EOT power is ON and provides lamp test of all EQT lamps (white).
14	HALF ASTERN	Indicates order for starboard engine half speed astern (yellow).

Table 2-1. Description of Operator's Controls and Indicators - CONT

Key	Control or Indicator	Function
Engine Order Telegraph (EOT) (FIGURE 2-5) - continued		
15	DIMMER	Controls illumination level of EOT power lamps (white).
16	FULL ASTERN	Indicates order for starboard engine full speed astern (yellow).
17	FULL ASTERN	Indicates order for port engine full speed astern (yellow).
18	HALF ASTERN	Indicates order for port engine half speed astern (yellow).
19	SLOW ASTERN	Indicates order for port engine slow speed astern (yellow).
20	DEAD SLOW ASTERN	Indicates order for port engine dead slow speed astern (yellow).
21	PORT WRONG DIRECTION	Indicates port engine wrong order given at EOS (red).
22	STOP	Indicates order to STOP port engine (red).
23 CANCEL	STANDBY (yellow).	Indicates order to cancel standby command
24	DEAD SLOW AHEAD	Indicates order for port engine dead slow speed ahead (green).
25	STANDBY	Indicates order to STANDBY for further directions (yellow).
26	SLOW AHEAD	Indicates order for port engine slow speed ahead (green).
27	FINISHED WITH ENGINES	Indicates order to shutdown engine (white).
28	HALF AHEAD	Indicates order for port engine half speed ahead (green).

Table 2-1. Description of Operator's Controls and Indicators - CONT

Key	Control or Indicator	Function
Bow Ramp Control Panel (FIGURE 2-6)		
1	POWER ON-OFF	Two position switch controls electrical power to bow ramp system.
2	HIGH TEMP	Indicates hydraulic fluid temperature is above normal operating temperature (red).
3	TENSION	Indicates excessive slack in wire rope (amber).
4	TENSION	Pushbutton increases tension on wire rope.
5	RAISE LOWER	Movement of control lever raises or lowers bow ramp.
6	STOP	Pushbutton to STOP hydraulic pump.
7	START	Pushbutton to START hydraulic pump.
8	RUN	Indicates hydraulic pump is operating (green).

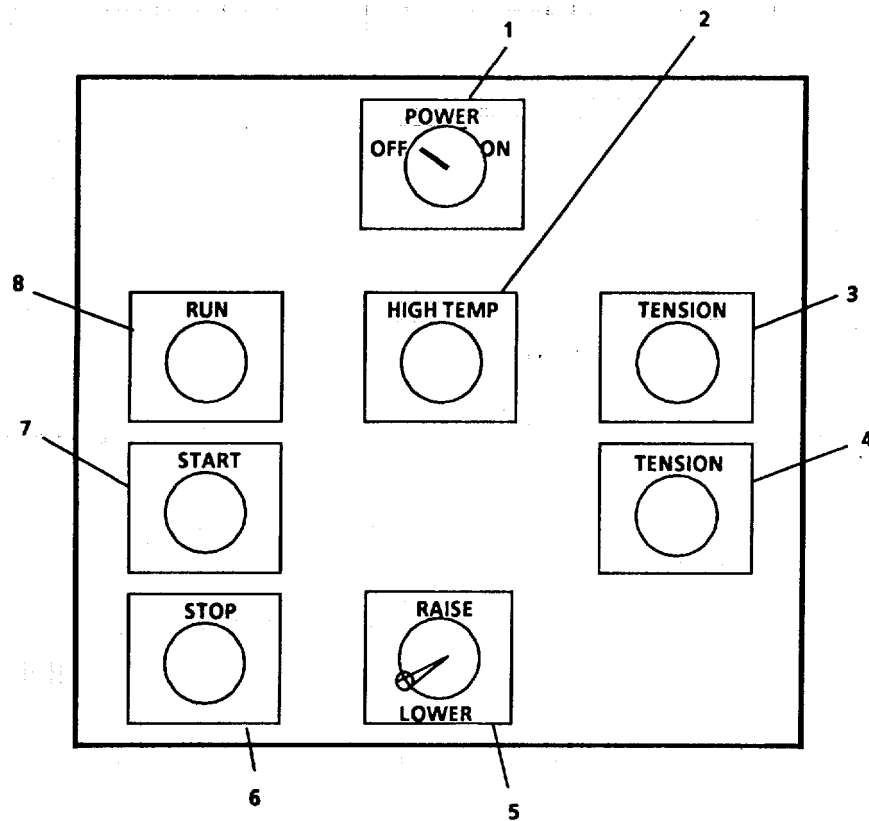

FIGURE 2-6. Bow Ramp Control Panel.

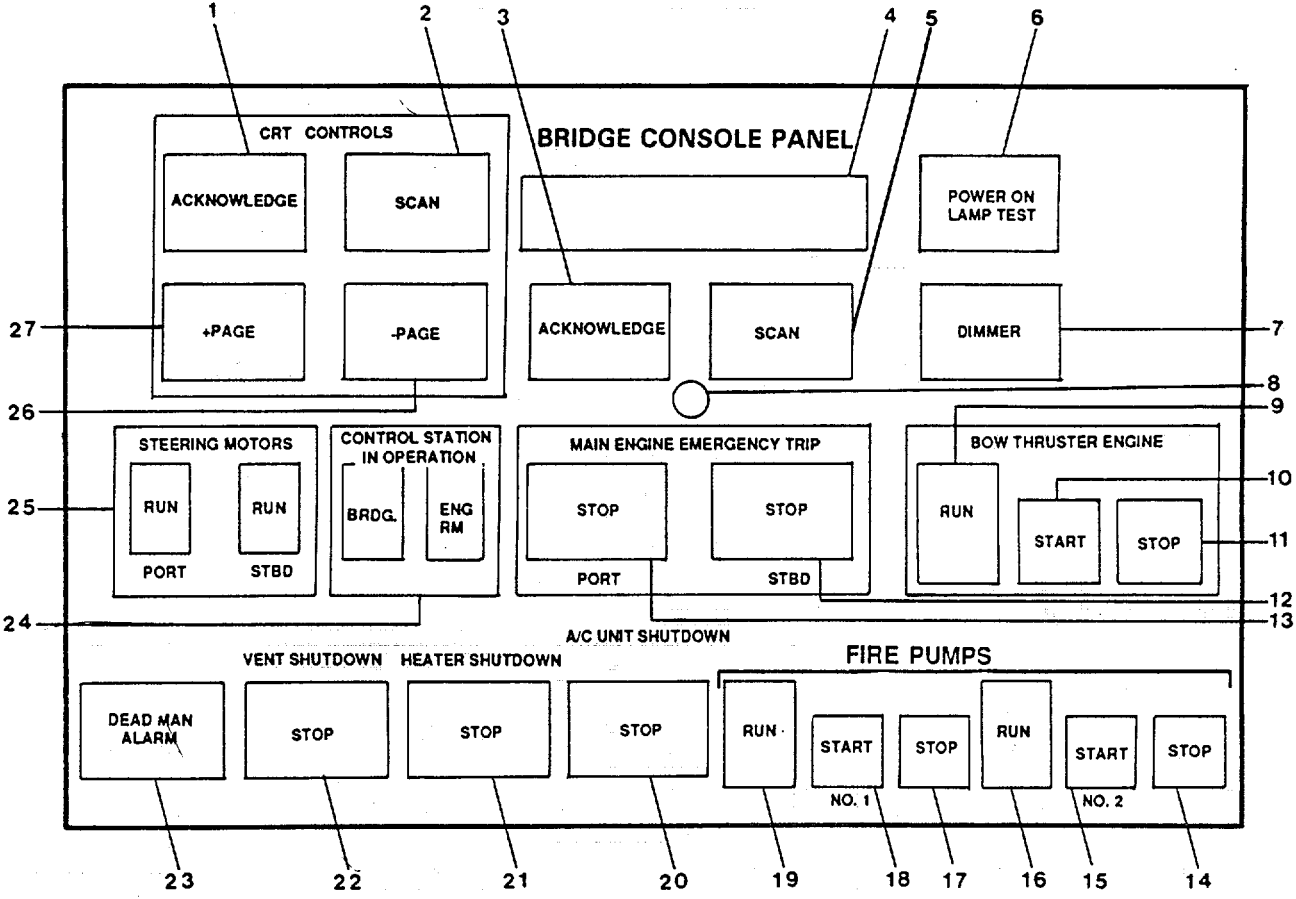

FIGURE 2-7. Bridge Console Panel.

Table 2-1. Description of Operator's Controls and Indicators - CONT

Key	Control or Indicator	Function
Bridge Console Panel (FIGURE 2-7)		
1	ACKNOWLEDGE	Pushbutton will turn OFF the alarm on the CRT and on the Bridge Console Panel.
2	SCAN	Pushbutton will cause alarm messages to be displayed on the CRT in reverse order of occurrence (white).
3	ACKNOWLEDGE	Pushbutton will turn OFF the alarm on the CRT and on the Bridge Console Panel.
4	Display	Displays alarm messages or date/time.
5	SCAN	Pushbutton will cause alarm messages to be displayed on the Bridge Console Panel Display (4) in reverse order of occurrence.
6	POWER ON LAMP TEST	Indicates bridge console panel is powered. When depressed, provides test of all panel lamps.
7	DIMMER	Controls panel illumination level (white).
8	Alarm	Provides audible alarm signal.
9	RUN	Indicates bowthruster engine is operating
10	START	Pushbutton activates bowthruster engine (green).
11	STOP	Pushbutton stops bowthruster engine (red).
12	STOP	Pushbutton activates starboard main engine emergency trip circuit for engine shutdown (red).
13	STOP	Pushbutton activates PORT main engine emergency trip circuit for engine shutdown (red).
14	STOP	Pushbutton stops No. 2 firepump (red).
15	START	Pushbutton activates No. 2 firepump (green).
16	RUN	Indicates No. 2 firepump is operating (white).
17	STOP	Pushbutton stops No. 1 firepump (red).
18	START	Pushbutton activates No. 1 firepump (green)

Table 2-1. Description of Operator's Controls and Indicators - CONT

Key	Control or Indicator	Function
Bridge Console Panel (FIGURE 2-7) - Continued		
19	RUN	Indicates No. 1 firepump is operating (white).
20	STOP	Pushbutton shuts down 15 ton air conditioner unit (red).
21	STOP	Pushbutton shuts down all heaters with a fan.
22	STOP	Pushbutton shuts down engine room supply and exhaust fans.
23	DEAD MAN ALARM	Indicates engine room operator has not responded to DEAD MAN ALARM signal on ENGINE ROOM CONSOLE PANEL.
24	CONTROL STATION IN OPERATION	Indicates BRDG (bridge) or ENG RM (engine room) in operational control (white).
25	STEERING MOTORS	Indicates PORT or starboard steering motor is operating (white).
26	- PAGE	Pushbutton moves CRT display back one page (white).
27	+ PAGE	Pushbutton moves CRT display forward one page (white).

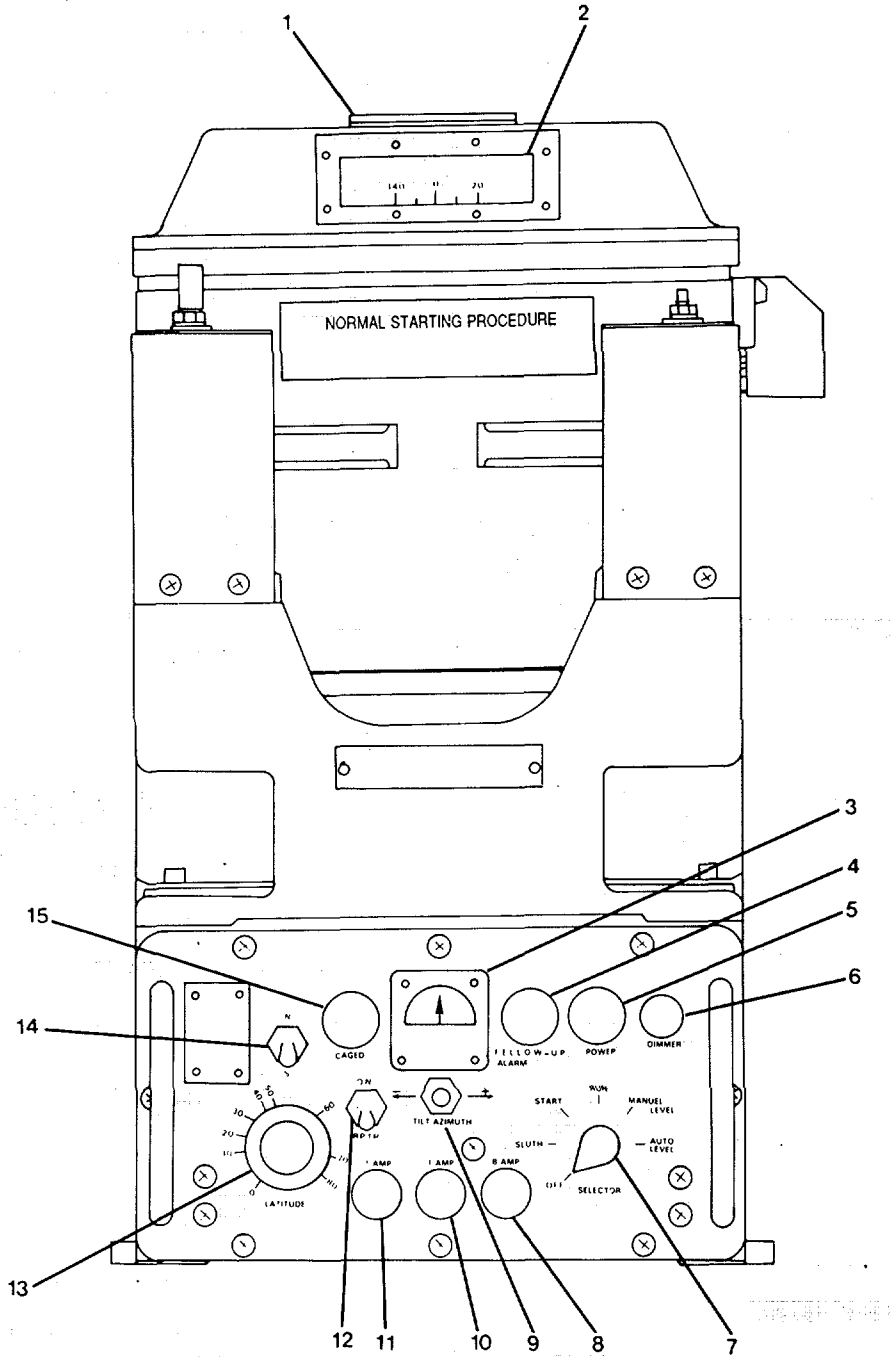

FIGURE 2-8. Gyro Compass Mark 27 Mod 1 Electronic Control Panel.

(2-23 blank)/2-24

Table 2-1. Description of Operator's Controls and Indicators - CONT

Key	Control or Indicator	Function
Gyro Compass Mark 27 Mod 1 Electronic Control Panel (FIGURE 2-8)		
1	Caged Button	Pushbutton cages gyro compass.
2	Viewing Window	Allows gyrocompass heading check.
3	Level Meter	Indicates tilt of gyroscope spin axis; 2 minutes per division.
4	FOLLOW-UP ALARM	Illuminated, the gyro compass would lose one axis of freedom and could no longer be considered a gyroscope.
5	POWER	Indicates power available to circuits (red).
6	DIMMER	Controls illumination level of compass card on master compass.
7	SELECTOR	SLEW position energizes all circuits except gyroscope motor and repeaters; in START position, gyroscope is brought up to speed; in RUN position, TILT/AZIMUTH switch is not energized; in MANUAL LEVEL position, TILT/AZIMUTH switch is energized; in AUTO LEVEL position, gyroscope is brought to approximate level position. OFF position turns system off.
8	8 AMP	Fuse protects internal power supply.
9	TILT/AZIMUTH	Controls gyro compass direction of rotation and supplies tilt signal.
10	1 AMP	Fuse protects 120 volt ac circuit.
11	1 AMP	Fuse protects repeater internal power supply.
12	RPTR	Switch applies power to repeaters.
13	LATITUDE	Compensates for ship's latitude.
14	N-S	Set for north or south latitude depending upon ship's location.
15	CAGED	Indicates gyroscope is caged (red).



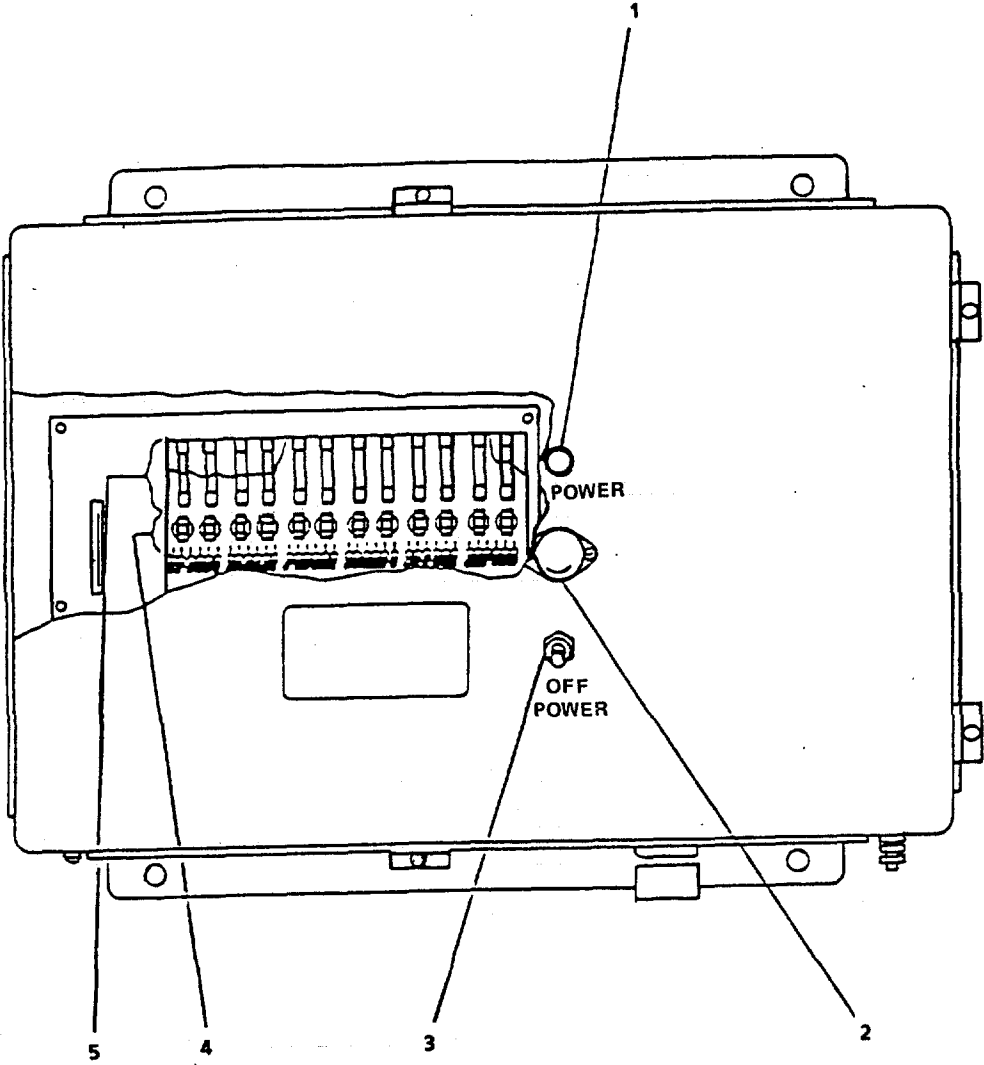

FIGURE 2-9. MK 37 Mod E Transmission Unit.

Table 2-1. Description of Operator's Controls and Indicators - CONT

Key	Control or Indicator	Function
MK 37 Mod E Transmission Unit (FIGURE 2-9)		
1	POWER	Illuminates to indicate transmission unit ac power is turned on.
2	FI	Fuse (8 amp) protects transmission unit ac input circuit.
3	OFF POWER	Control of ship's ac input power to transmission unit.
4	Repeater Switches A2S1 Through A2S12	Control of dc (B+) power to each step repeater load.
5	Repeater Fuses A2F1 Through A2F12	Protect B+ power circuit to each repeater load.

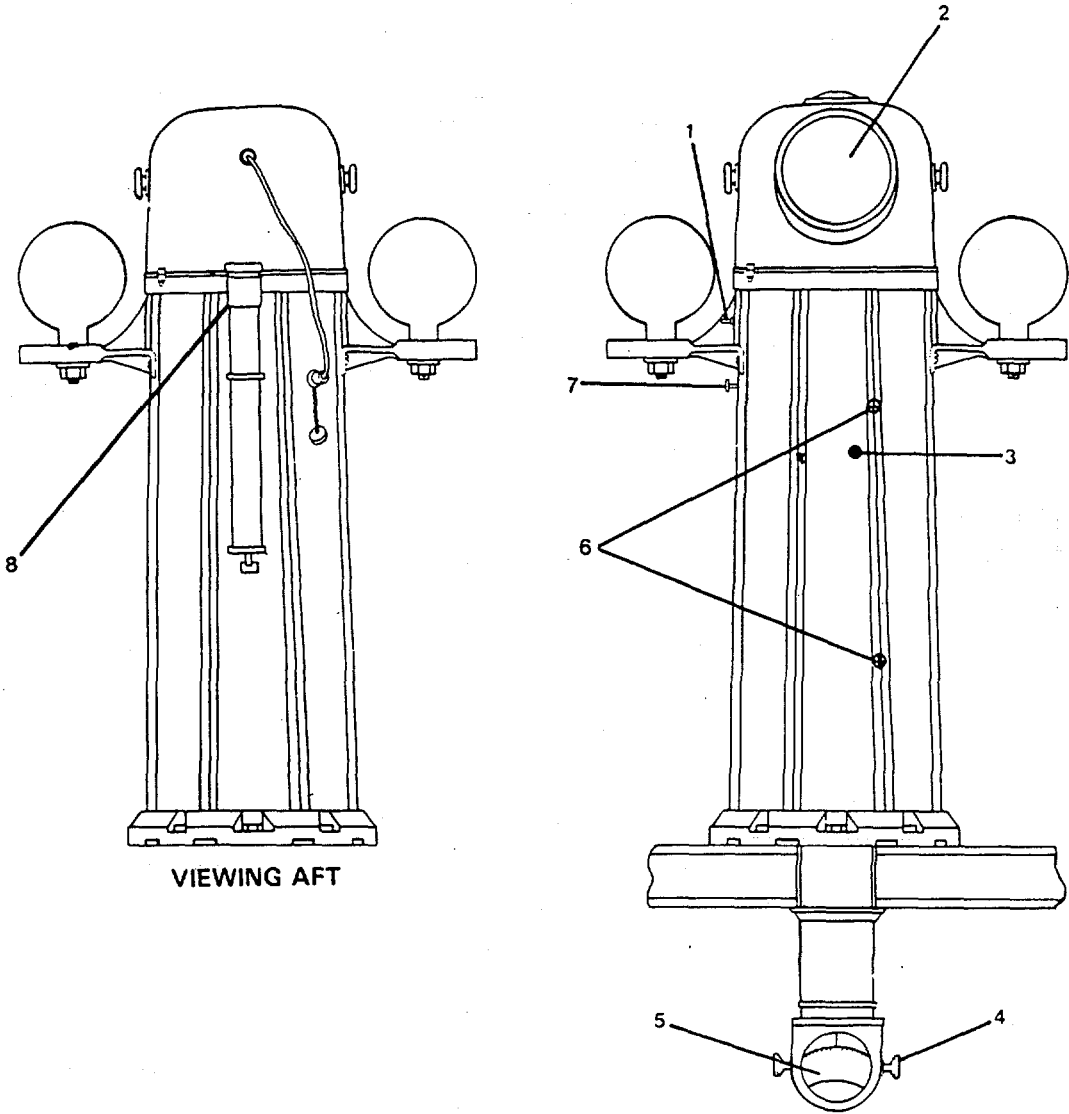

FIGURE 2-10. Magnetic Compass.

Table 2-1. Description of Operator's Controls and Indicators - CONT

Key	Control or Indicator	Function
<b>Magnetic Compass (FIGURE 2-10)</b>		
1	Toggle Switch	Controls binnacle light.
2	Viewing Window	Window for viewing compass.
3	Door Knob	Knob to open door.
4	Mirror Adjustment Knobs	Adjusts reflector mirrors.
5	Reflector Mirror	Provides magnetic compass face viewing in pilothouse.
6	Screws	Access cover securing screws.
7	Rehoestat Knob	Adjusts magnetic compass illumination level.
8	Flinders Bar	Adjusts vertical magnetic field.

Table 2-1. Description of Operator's Controls and Indicators - CONT

Key	Control or Indicator	Function
<b>Standard Bearing Repeater (FIGURE 2-11)</b>		
1	Lubber Line	Indicates heading when read against repeater card.
2	Repeater Card	Read against lubber line to indicate heading.
3	Synchronizer Knob	Synchronizes repeater with master gyro compass
4	Dimmer	Controls illumination of compass repeater.

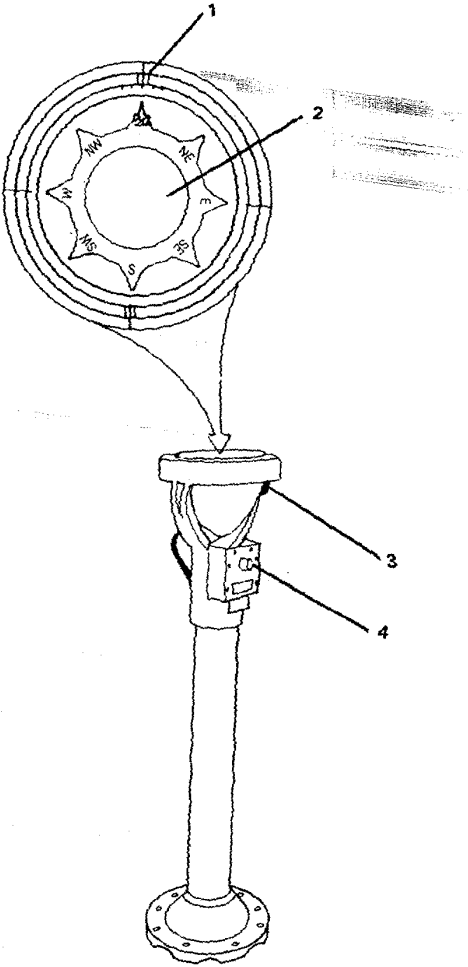

FIGURE 2-11. Standard Bearing Repeater.

Table 2-1. Description of Operator's Controls and Indicators - CONT

Key	Control or Indicator	Function
<b>Open Scale Compass Repeater (FIGURE 2-12)</b>		
1	Dimmer	Controls illumination level of compass repeater.
2	Cover over ON-OFF Switch	Protects compass synchronizer control ON-OFF switch.
3	Synchronizer Knob	Synchronizes repeater reading manually, when synchronizer control is OFF.
4	Repeater Card	Read directly against lubber line to indicate heading.
5	Lubber Line	Indicates heading when read against repeater card.
6	Mask	Has cutouts for ten degree repeater card markings and notches for five degree repeater card markings.

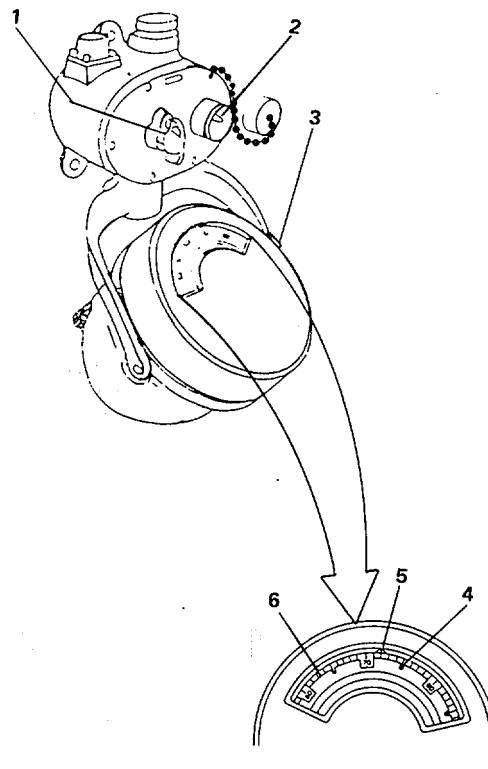

FIGURE 2-12. Open Scale Compass Repeater.

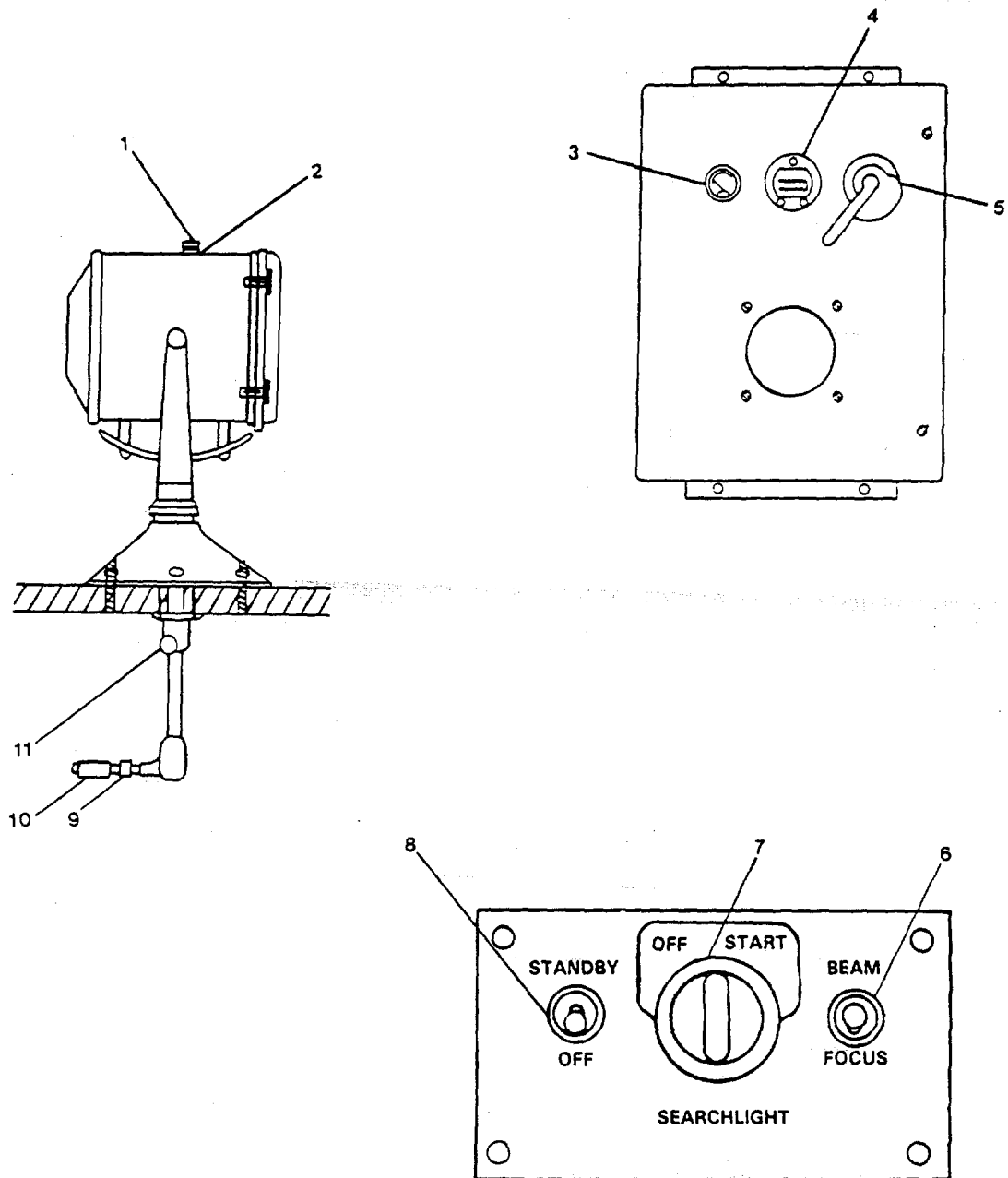

FIGURE 2-13. 500 Watt Xenon Searchlight.

Table 2-1. Description of Operator's Controls and Indicators - CONT

Key	Control or Indicator	Function
<b>500 Watt Xenon Searchlight (FIGURE 2-13)</b>		
1	Manual Focus Knob	Focused FORE and AFT along the axis of the reflector by means of the manual focus knob on top of the drum without the use of tools.
2	Lock Knob	Locks Manual Focus Knob in place.
3	Ammeter	Indicates lamp current.
4	Elapsed Time	Indicates lamp burning time.
5	ON-OFF OPEN COVER RESET	Controls electrical power to searchlight and provides power for control functions.
6	BEAM FOCUS	Hold switch in BEAM or FOCUS position until beam is desired diameter. Switch returns to neutral and beam diameter remains "as is" when switch is released.
7	OFF-START	Turn searchlight on by moving switch to START just long enough to start lamp and release. Move switch to OFF to turn light OFF.
8	STANDBY-OFF	Turn STANDBY switch to OFF if searchlight is not going to be used for several hours; otherwise, leave it in STANDBY.
9	Vertical Lock Knob	Provides a positive lock for the vertical position.
10	Lever Handle	Lever handle aims searchlight by pointing lever handle in the horizontal direction desired. Beam is tilted up or down by twisting the lever handle. A spring friction brake holds the drum in any vertical position.
11	Horizontal Lock	Secures the horizontal position of the drum.



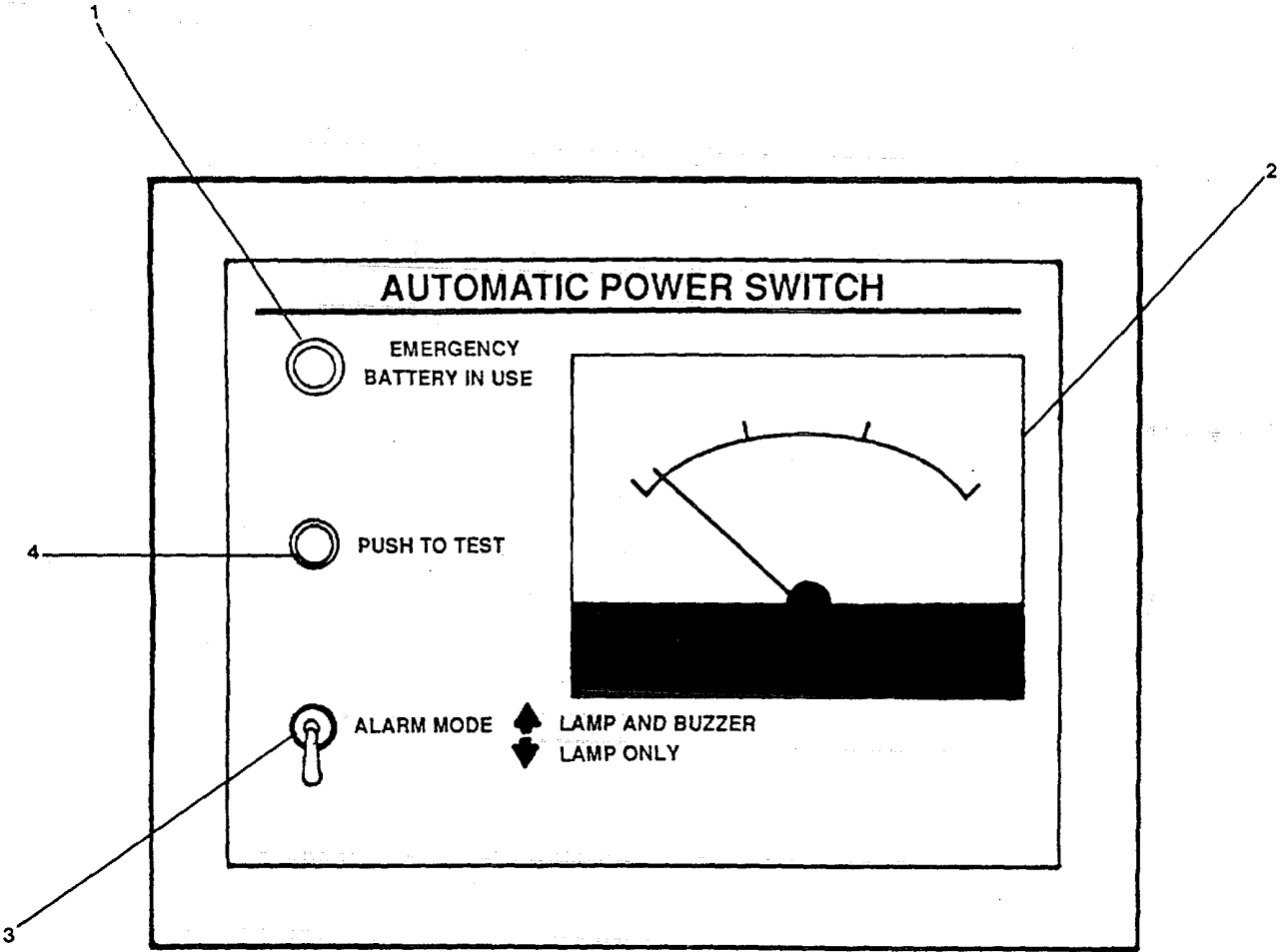

FIGURE 2-14. Automatic Power Switch.

Table 2-1. Description of Operator's Controls and Indicators - CONT

Key	Control or Indicator	Function
<b>Automatic Power Switch (FIGURE 2-14)</b>		
1	EMERGENCY BATTERY IN USE	Indicates power is coming from the emergency batteries.
2	Meter	Indicates power level of batteries.
3	ALARM MODE	Selects type of alarm to be used, either lamp only or lamp and buzzer.
4	PUSH TO TEST	Pushbutton used to test the EMERGENCY BATTERY IN USE (1) light.

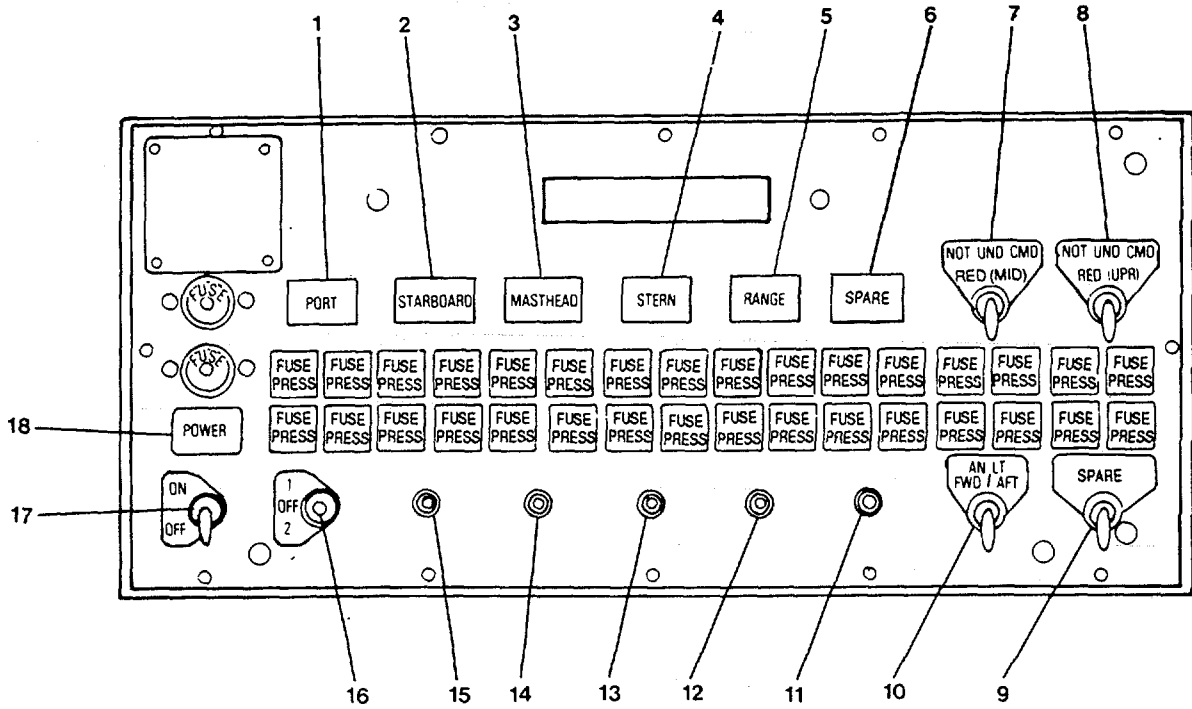

FIGURE 2-15. Navigation Light Panel.

Table 2-1. Description of Operator's Controls and Indicators - CONT

Key	Control or Indicator	Function
<b>Navigation Light Panel (FIGURE 2-15)</b>		
1	PORT	Indicates port side running light is turned on.
2	STARBOARD	Indicates starboard side running light is turned on.
3	MASTHEAD	Indicates masthead light is turned on.
4	STERN	Indicates stern light is turned on.
5	RANGE	Indicates range light is turned on.
6	SPARE	Not used.
7	NOT UND CMD RED (MID)	Toggle switch placed in ON position turns on middle not under command light (white).
8	NOT UND CMD RED (UPR)	Toggle switch placed in ON position turns on upper not under command light (red).
9	SPARE	Not used.
10	AN LT FWD & AFT	Toggle switch placed in ON position turns on forward and aft anchor light.
11	Range Light Switch	Toggle switch placed in ON position turns on range lights.
12	Stern Light Switch	Toggle switch placed in ON position turns on stern lights.
13	Mast Head Light Switch	Toggle switch placed in ON/position turns on mast head light.
14	Starboard Light Switch	Toggle switch placed in ON position turns on starboard running lights.
15	Port Light Switch	Toggle switch placed in ON position turns on port running lights.
16	1 OFF 2	Selects navigation light system 1, 2, or OFF.
17	ON OFF	Turns navigation light panel ON or OFF.
18	POWER	Indicates navigation light panel is turned ON.

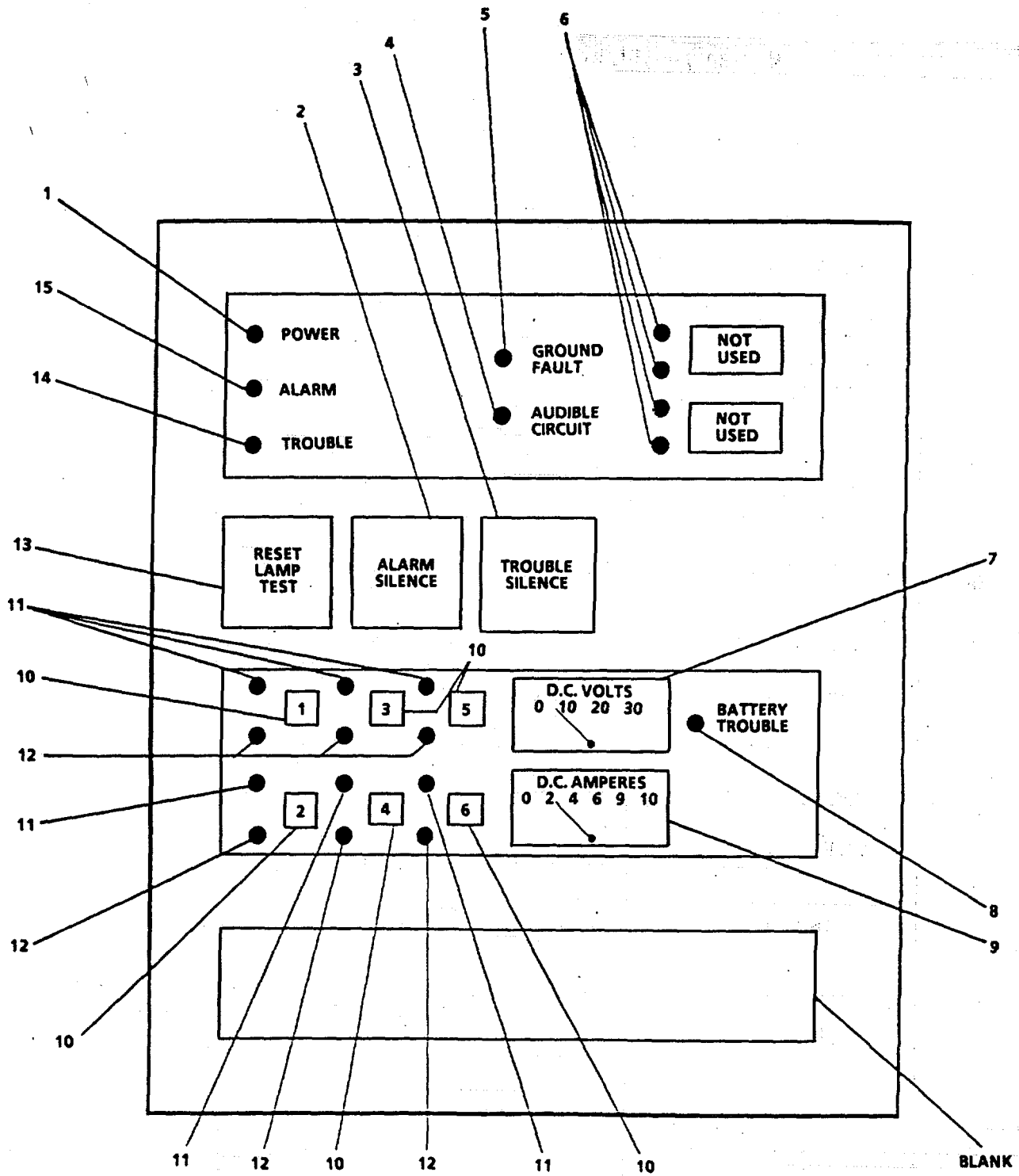

FIGURE 2-16. Marine Fire Detection Panel.

**Table 2-1. Description of Operator's Controls and Indicators - CONT**

Key	Control or Indicator	Function
<b>Marine Fire Detection Panel (FIGURE 2-16)</b>		
1	POWER	Indicates fire detection panel is activated. Flashes when on battery (green).
2	ALARM SILENCE	Pushbutton silences audible fire alarm.
3	TROUBLE SILENCE	Pushbutton silences audible trouble alarm.
4	AUDIBLE CIRCUIT	Indicates a fault in fire detector audible circuit (amber).
5	GROUND FAULT	Indicates ground fault in fire detector system (amber).
6	NOT USED	Not used.
7	D.C. VOLTS	Indicates fire detector system D.C. voltage.
8	BATTERY TROUBLE	Indicates loss of charge in battery system (amber).
9	D.C. AMPERES	Indicates fire detector D.C. amperage.
10	Zone Labels	Indicates zone of detection system.
11	LED Indicator	Indicates alarm for the zone (red).
12	LED Indicator	Indicates the zone is operational (amber).
13	RESET LAMP TEST	Pushbutton provides system lamp test and resets system after alarm has been silenced.
14	TROUBLE	Indicates trouble in fire detector system (amber).
15	ALARM	Indicates alarm for one or more zones (red). Flashes after alarm has been silenced.

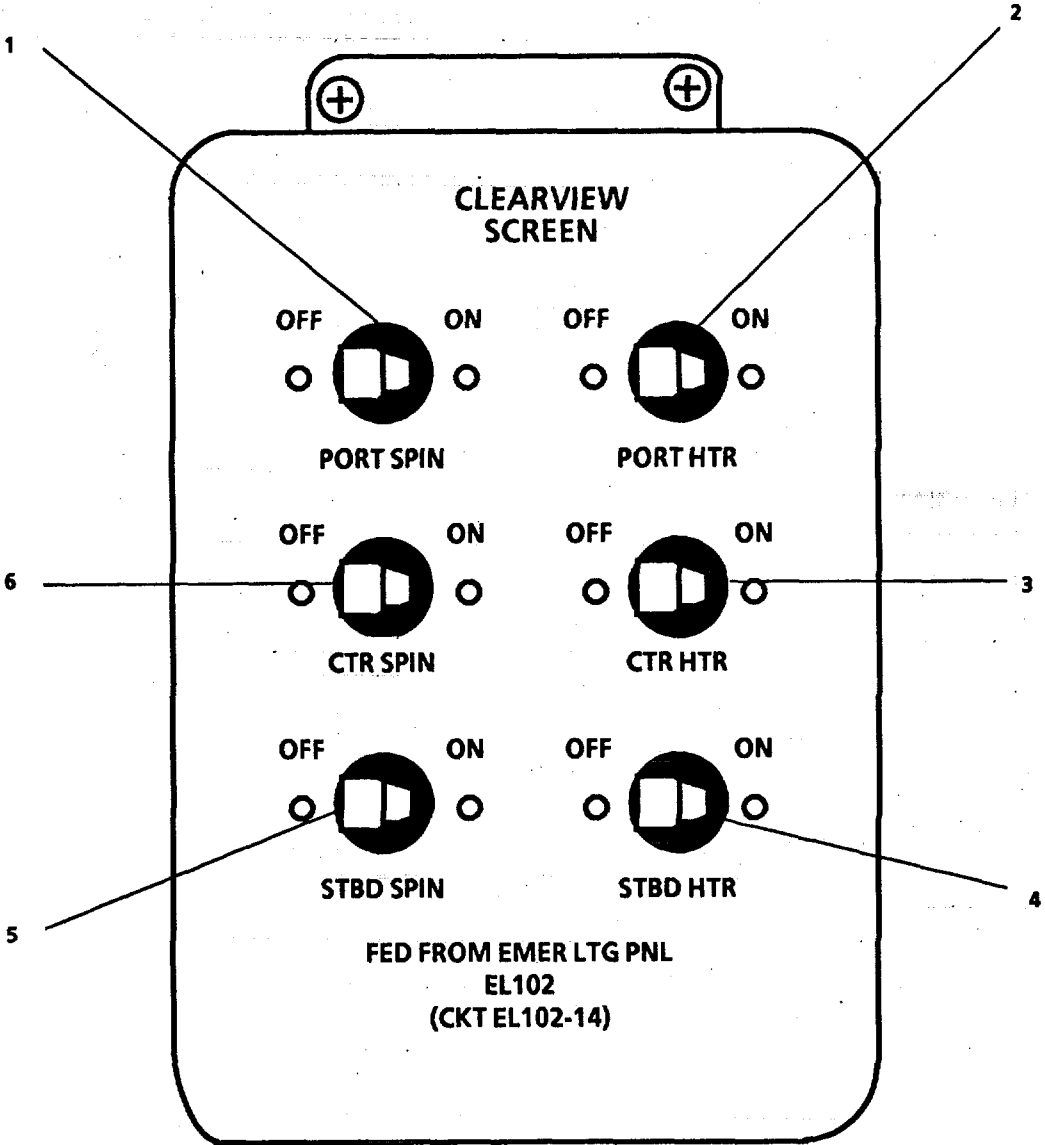

FIGURE 2-17. Clearview Screen Control Panel.

Table 2-1. Description of Operator's Controls and Indicators - CONT

Key	Control or Indicator	Function
<b>Clearview Screen Control Panel (FIGURE 2-17)</b>		
1	OFF                      ON PORT SPIN	ON-OFF control of spin of port clearview screen.
2	OFF                      ON PORT HTR	ON-OFF control for port clearview screen heater.
3	OFF                      ON CTR SPIN	ON-OFF control of spin of center clearview screen.
4	OFF                      ON CTR HTR	ON-OFF control for center clearview screen heater.
5	OFF                      ON STBD SPIN	ON-OFF control of spin of starboard clearview screen.
6	OFF                      ON STBD HTR	ON-OFF control for starboard clearview screen heater.



Table 2-1. Description of Operator's Controls and Indicators - CONT

Key	Control or Indicator	Function
<b>Sound Powered Telephone, Model SER (FIGURE 2-18)</b>		
1	Bell	Audible signal for incoming call.
2	Selector Dial	Outlines available stations.
3	Selector Knob	Selects station to be called.
4	Magneto Handle	Crank handle to call a station.
5	Handset	Communication instrument.

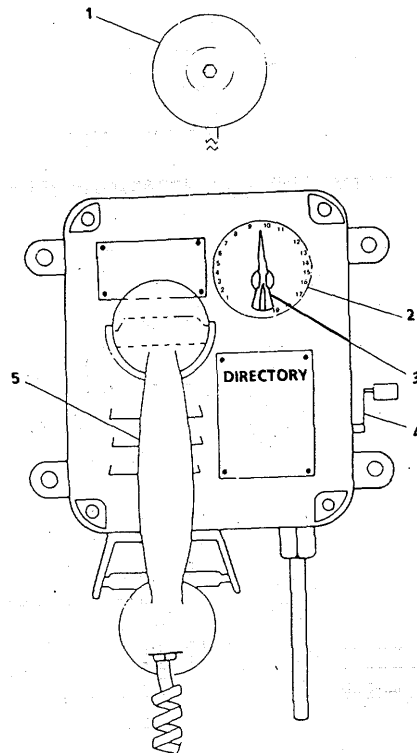

FIGURE 2-18. Sound Powered Telephone, Model SER.

Table 2-1. Description of Operator's Controls and Indicators - CONT

Key	Control or Indicator	Function
<b>Sound Powered Telephone, Model SELR (FIGURE 2-19)</b>		
1	Indicator Light	Indicates incoming call. (Red)
2	Selector Dial	Outlines available stations.
3	Selector Knob	Selects station to be called.
4	Magneto Handle	Crank handle to call selected station.
5	Handset	Communication instrument.

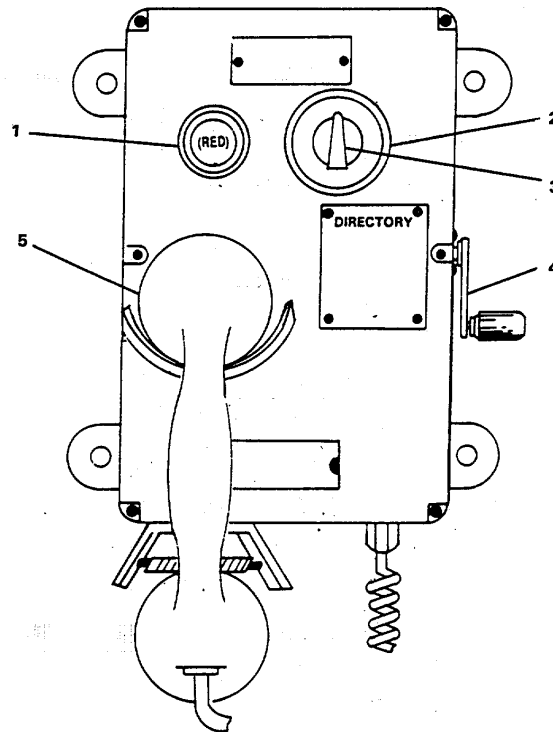

FIGURE 2-19. Sound Powered Telephone, Model SELR.

Table 2-1. Description of Operator's Controls and Indicators - CONT

Key	Control or Indicator	Function
<b>Sound Powered Telephone, Model SFLR (FIGURE 2-20)</b>		
1	Handset	Communication instrument.
2	Selector Dial	Outlines available stations.
3	Selector Knob	Selects station to be called.
4	Magneto Handle	Crank handle to call selected station.
5	Indicator Light	Indicates incoming call.
6	Reset Pushbutton	Pushbutton resets telephone for future incoming calls.
7	Handset Pushbutton	Press to transmit.

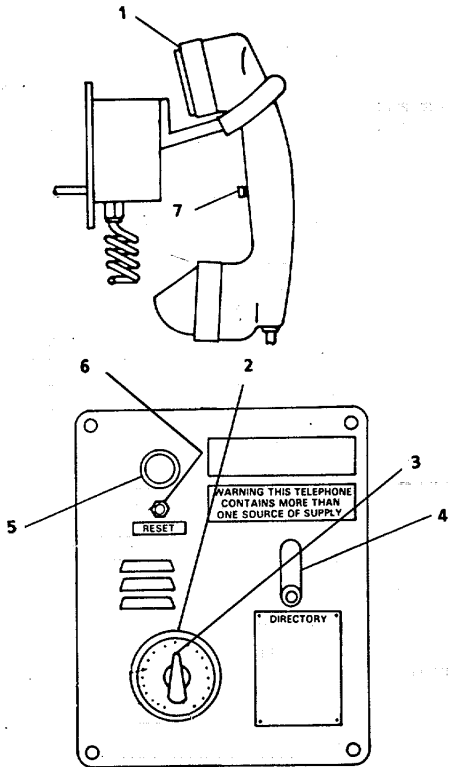

FIGURE 2-20. Sound Powered Telephone, Model SFLR.

Table 2-1. Description of Operator's Controls and Indicators - CONT

Key	Control or Indicator	Function
<b>Sound Powered Telephone, Model MWT-R (FIGURE 2-21)</b>		
1	Bell	Indicates incoming call (mounted near-by).
2	Selector Dial	Outlines available stations.
3	Selector Knob	Selects station to be called.
4	Magneto Handle	Crank handle to call a station.
5	Handset	Communication instrument.

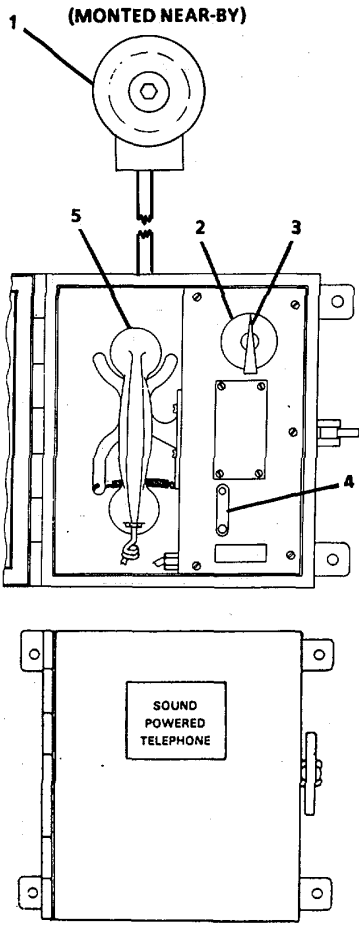

FIGURE 2-21. Sound Powered Telephone, Model MWT-R.

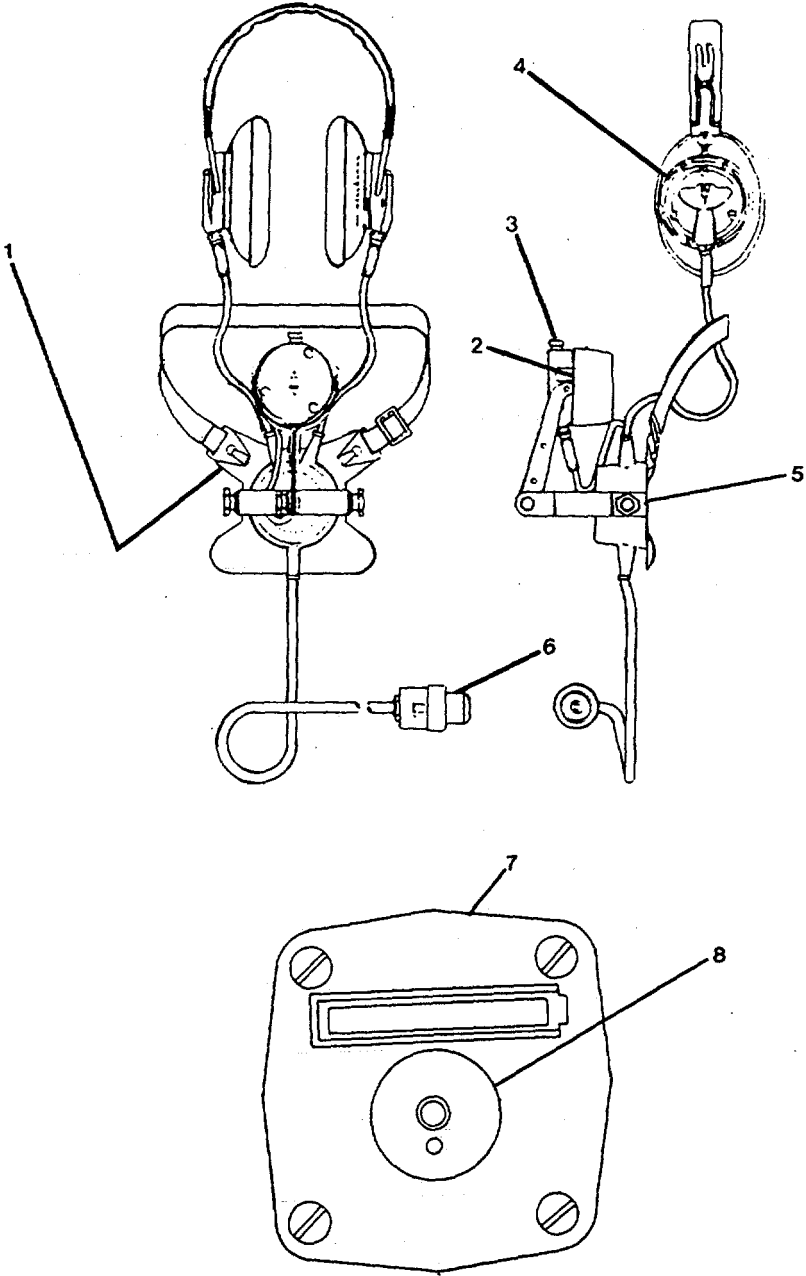

FIGURE 2-22. Head Set-Chest Set, Sound Powered.

Table 2-1. Description of Operator's Controls and Indicators - CONT

Key	Control or Indicator	Function
<b>Head Set-Chest Set, Sound Powered (FIGURE 2-22)</b>		
1	Hook	Fastner for web strap.
2	Mouth Piece	Holder for transmitter.
3	Pushbutton	Keys microphone.
4	Headset	Contains headphone type receiver.
5	Support Bracket	Provides chest support for head set-chest set sound powered telephone.
6	Jack Plug	Connects head set-chest set to jack box.
7	Telephone Jack Box	Watertight box for jack socket (accepts the H39A plug)
8	Jack Cover	Watertight cover for socket

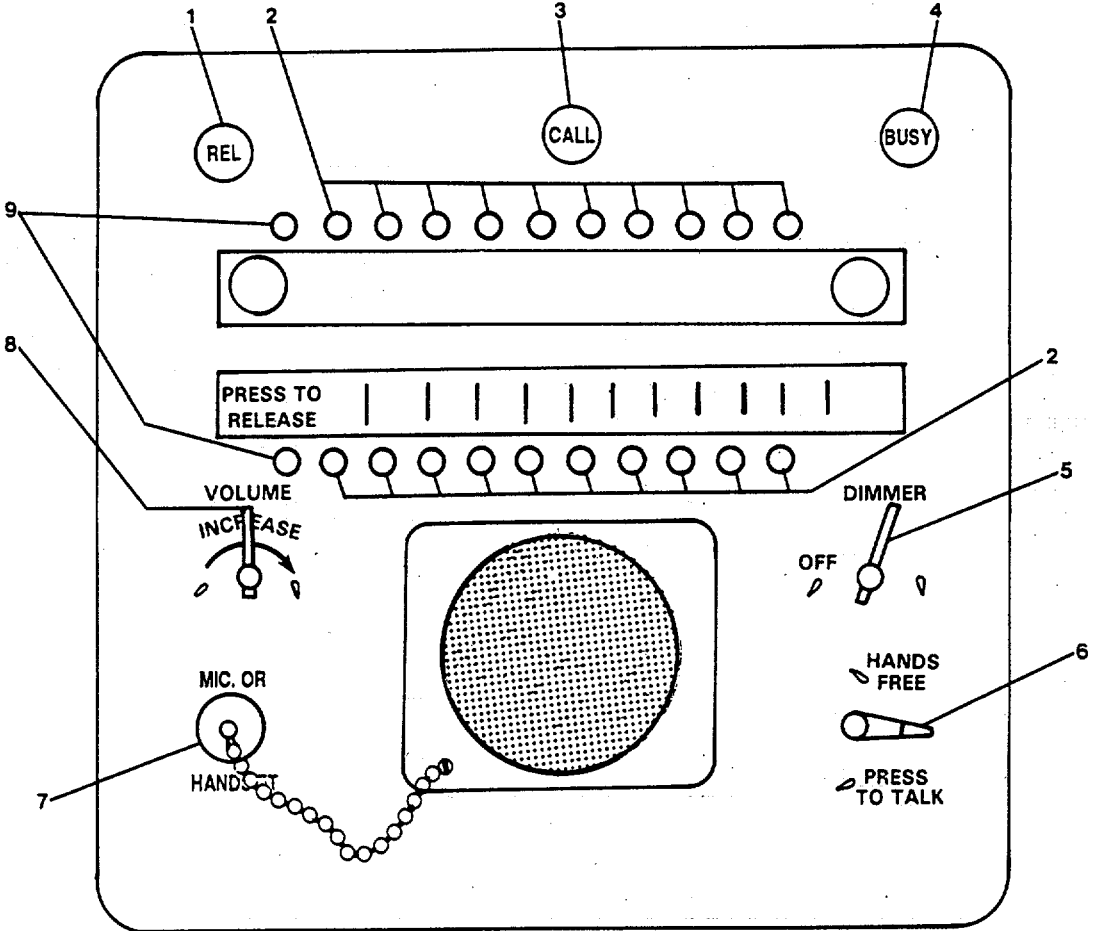

FIGURE 2-23. Intercom Panel, LS-519 / SIC (U).

Table 2-1. Description of Operator's Controls and Indicators - CONT

Key	Control or Indicator	Function
<b>Intercom Panel, LS-519 / SIC (U) (FIGURE 2-23)</b>		
1	REL	Indicates release of system is needed (red).
2	STATION PUSHBUTTON	Connects unit to selected station.
3	CALL	Indicates incoming call (red).
4	BUSY	Indicates system is in use (red).
5	DIMMER	Controls illumination level of intercom panel.
6	HANDS FREE	Provides hands free or press to talk transmission modes.
7	MIC OR HANDSET	Jack plug for external microphone/handset.
8	VOLUME INCREASE	Control sound level of intercom.
9	PRESS TO RELEASE	Releases station pushbuttons.



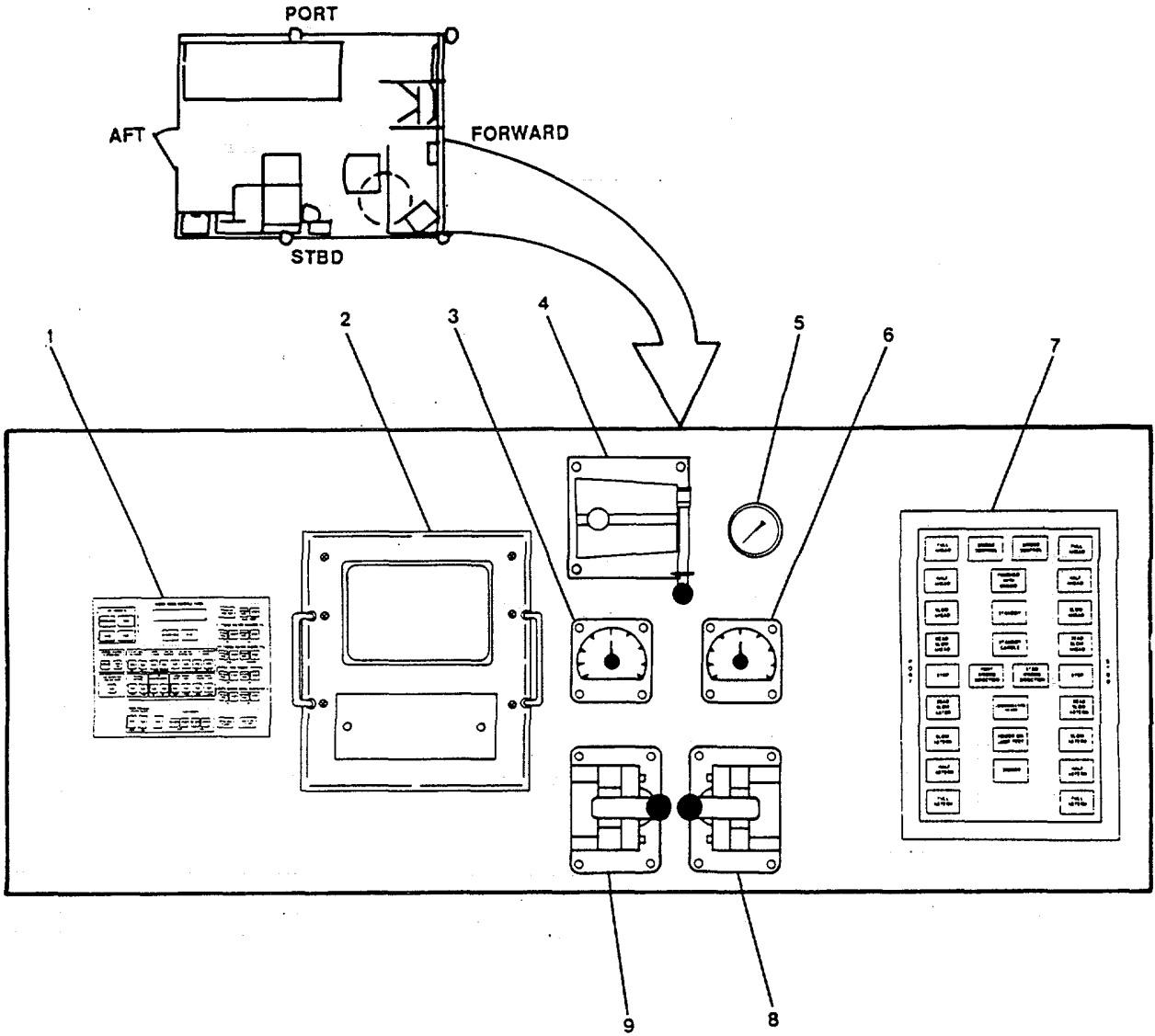

FIGURE 2-24. Engine Room Console.

**Table 2-1. Description of Operator's Controls and Indicators - CONT**

Key	Control or Indicator	Function
<b>Engine Room Console (FIGURE 2-24)</b>		
1	ENGINE ROOM CONSOLE PANEL	Provides equipment operation controls and information.
2	CRT-MCHRY SYSTEMS MONITOR	Provides continuous readout for engines and subsystems.
3	TACH-PORT SHAFT	Indicates port shaft RPM.
4	CONTROL AIR STA SEL VALVE	Transfers control air from/to EOS, neutral, or bridge.
5	THROTTLE AIR PRESS	Indicates psi reading of the control air pressure system.
6	TACH-STBD SHAFT	Indicates starboard shaft RPM.
7	ENGINE ORDER TELEGRAPH	Indicates desired vessel speed and direction signals from bridge.
8	THROTTLE-STBD ENG	Controls speed of the starboard main engine and direction of starboard shaft.
9	THROTTLE-PORT ENG	Controls speed of the port main engine and direction of port shaft.

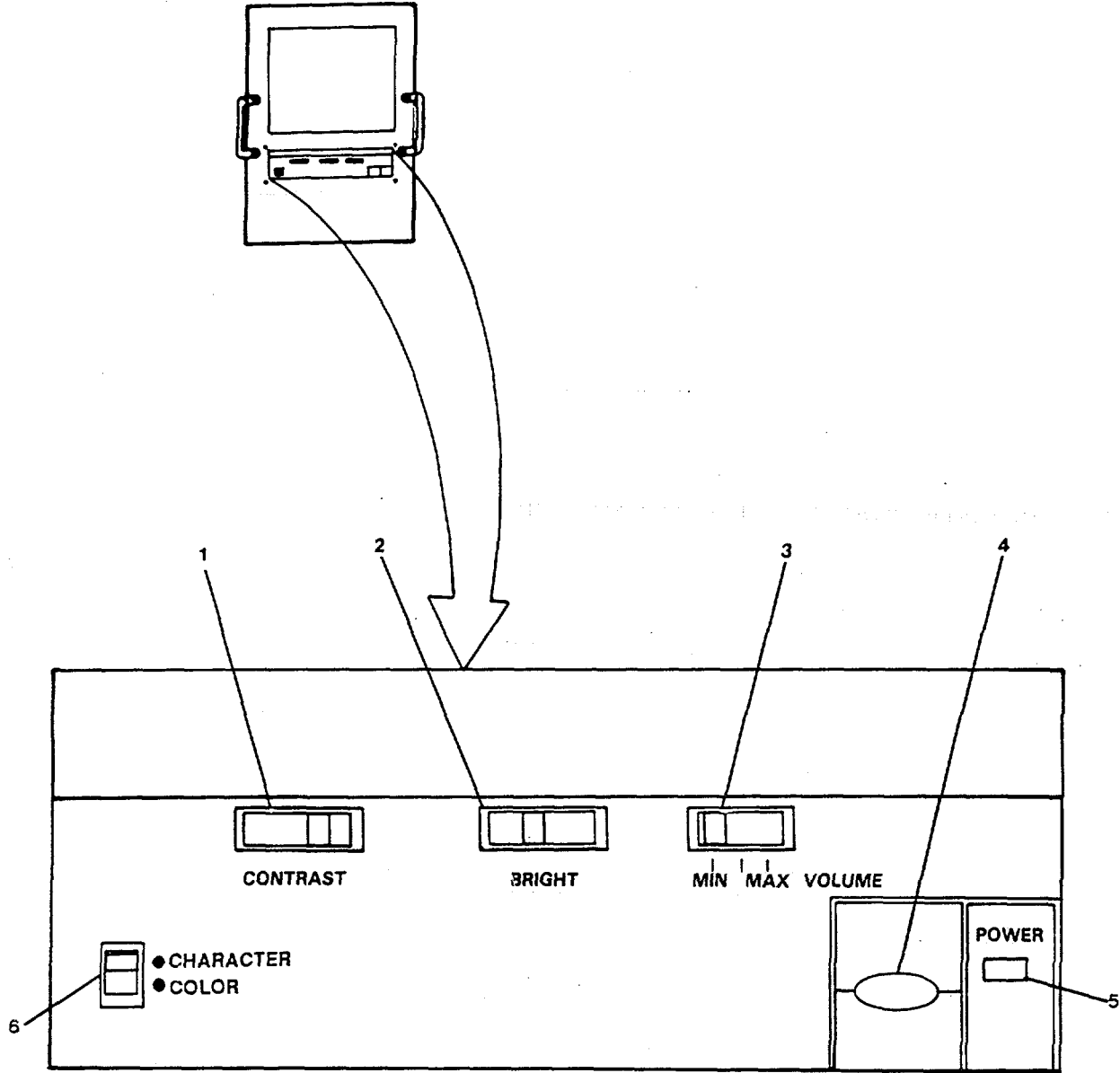

FIGURE 2-25. Machinery Plant Monitor Panel.

**Table 2-1. Description of Operator's Controls and Indicators - CONT**

Key	Control or Indicator	Function
<b>Machinery Plant Monitor Panel (FIGURE 2-25)</b>		
1	CONTRAST	Adjusts contrast of machinery plant monitor.
2	BRIGHT	Adjusts brightness of machinery plant monitor.
3	MIN-MAX VOLUME	Adjusts volume of machinery plant monitor alarm.
4	POWER	Provides ON-OFF power control of machinery plant monitor.
5	POWER	Indicator light that lights when power is on.
6	CHARACTER/COLOR	Two position pushbutton switch. In up position the CRT is in color. In down position CRT is in black and white

Table 2-1. Description of Operator's Controls and Indicators - CONT

Key	Control or Indicator	Function
<b>Engine Room Console Panel (FIGURE 2-26)</b>		
1	ACKNOWLEDGE	Pushbutton will turn OFF the alarm relay (red).
2	SCAN	Pushbutton will cause alarm messages to be displayed in reverse order of occurrence on the Machinery Plant Monitor (white).

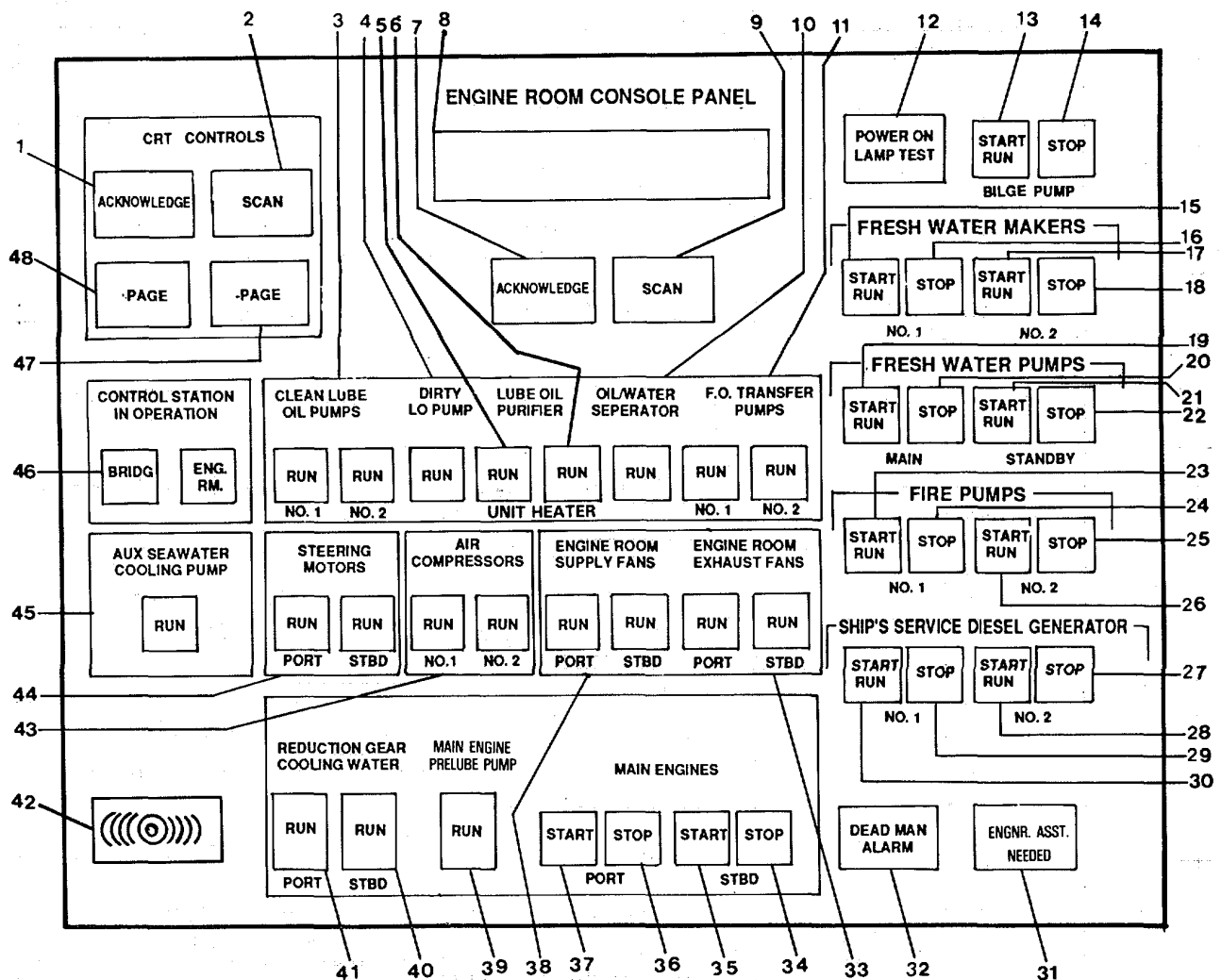

FIGURE 2-26. Engine Room Console Panel.

Table 2-1. Description of Operator's Controls and Indicators - CONT

Key	Control or Indicator	Function
<b>Engine Room Console Panel (FIGURE 2-26) - Continued</b>		
3	CLEAN LUBE OIL PUMPS	Indicates No. 1 or No. 2 pump is transferring clean lubricating oil to engine sumps (white).
4	DIRTY LO PUMP	Indicates pump is transferring dirty lubricating oil off the vessel to a shore facility.
5	LUBE OIL PURIFIER UNIT	Indicates the LUBE OIL PURIFIER UNIT is operating (white).
6	LUBE OIL PURIFIER HEATER	Indicates LUBE OIL PURIFIER HEATER is operating (white).
7	ACKNOWLEDGE	Pushbutton will turn OFF the alarm relay (red).
8		Display CRT which displays alarm message.
9	SCAN	Pushbutton will cause alarm messages to be displayed in reverse order of occurrence (white).
10	OIL/WATER SEPARATOR	Indicates OIL/WATER SEPARATOR is operating (white).
11	F.O. TRANSFER PUMPS	Indicates No. 1 or No. 2 F.O. TRANSFER PUMP is operating (white).
12	POWER ON LAMP TEST	Illuminated, indicates ENGINE ROOM CONSOLE PANEL is powered. Depressed, provides test of all panel lamps (white).
13	START RUN	Pushbutton starts BILGE PUMP. Illuminated, indicates BILGE PUMP is operating (green).
14	STOP	Pushbutton stops BILGE PUMP (red).
15	START RUN	Pushbutton starts No. 1 FRESH WATER MAKER. Illuminated, indicates No. 1 FRESH WATER MAKER is operating (green).
16	STOP	Pushbutton stops No. 1 FRESH WATER MAKER (red).
17	START RUN	Pushbutton starts No. 2 FRESH WATER MAKER. Illuminated, indicates No. 2 FRESH WATER MAKER is operating (green).

Table 2-1. Description of Operator's Controls and Indicators - CONT

Key	Control or Indicator	Function
<b>Engine Room Console Panel (FIGURE 2-26) - Continued</b>		
18	STOP	Pushbutton stops No. 2 FRESH WATER MAKER (red).
19	START RUN	Pushbutton starts MAIN FRESH WATER PUMP. Illuminated, indicates MAIN FRESH WATER PUMP is operating (green).
20	STOP	Pushbutton stops MAIN FRESH WATER PUMP (red).
21	START RUN	Pushbutton starts STANDBY FRESH WATER PUMP. Illuminated, indicates STANDBY FRESH WATER PUMP is operating (green).
22	STOP	Pushbutton stops STANDBY FRESH WATER PUMP (red).
23	START RUN	Pushbutton starts No. 1 FIRE PUMP. Illuminated, indicates No. 1 FIRE PUMP is operating (green).
24	STOP	Pushbutton stops No. 1 FIRE PUMP (red).
25	STOP	Pushbutton stops No. 2 FIRE PUMP (red).
26	START RUN	Pushbutton starts No. 2 FIRE PUMP. Illuminated, indicates No. 2 FIRE PUMP is operating (green).
27	STOP	Pushbutton stops No. 2 SHIP SERVICE DIESEL GENERATOR (red).
28	START RUN	Pushbutton starts No. 2 SHIP SERVICE DIESEL GENERATOR. Illuminated indicates generator is operating (green).
29	STOP	Pushbutton stops No. 1 SHIP SERVICE DIESEL GENERATOR (red).
30	START RUN	Pushbutton starts No. 1 SHIP SERVICE DIESEL GENERATOR. Illuminated, indicates generator is operating (green).
31	ENGNR. ASST. NEEDED	Turns on alarm in mess deck and Chief Engineer's stateroom to indicate engineer assistance needed (red).

Table 2-1. Description of Operator's Controls and Indicators - CONT

Key	Control or Indicator	Function
<b>Engine Room Console Panel (FIGURE 2-26) - Continued</b>		
32	DEAD MAN ALARM	Lights every 15 minutes for operator to respond by pushing button to prevent alarm on Bridge Console Panel and Engineer Assistance Needed alarm (red).
33	ENGINE ROOM EXHAUST EXHAUST FANS	Indicates PORT or starboard ENGINE ROOM FAN is operating.
34	STOP	Pushbutton stops starboard MAIN ENGINE (red).
35	START	Pushbutton starts starboard MAIN ENGINE (green).
36	STOP	Pushbutton stops PORT MAIN ENGINE (red).
37	START	Pushbutton starts PORT MAIN ENGINE (green).
38	ENGINE ROOM SUPPLY FANS	Indicates PORT or starboard ENGINE ROOM SUPPLY FAN is operating (white).
39	RUN	Indicates MAIN ENGINE PRELUBE PUMP is operating (white).
40	RUN WATER pump is operating (white).	Indicates STBD REDUCTION GEAR COOLING
41	RUN WATER pump is operating (white).	Indicates PORT REDUCTION GEAR COOLING
42	Alarm Signal	Alarm sounds when equipment monitored by engine room console panel has malfunctioned.
43	AIR COMPRESSORS	Indicates No. 1 or No. 2 AIR COMPRESSOR is operating (white).
44	STEERING MOTORS	Indicates PORT or STBD STEERING MOTOR is operating (white).
45	AUX SEA WATER COOLING PUMP	Indicates AUX SEA WATER COOLING PUMP is operating (white).
46	CONTROL STATION IN OPERATION	Indicates BRIDG (bridge) or ENG RM (engine room) is in operational control (white).
47	- PAGE	Moves display back one page.
48	+ PAGE	Moves display forward one page.



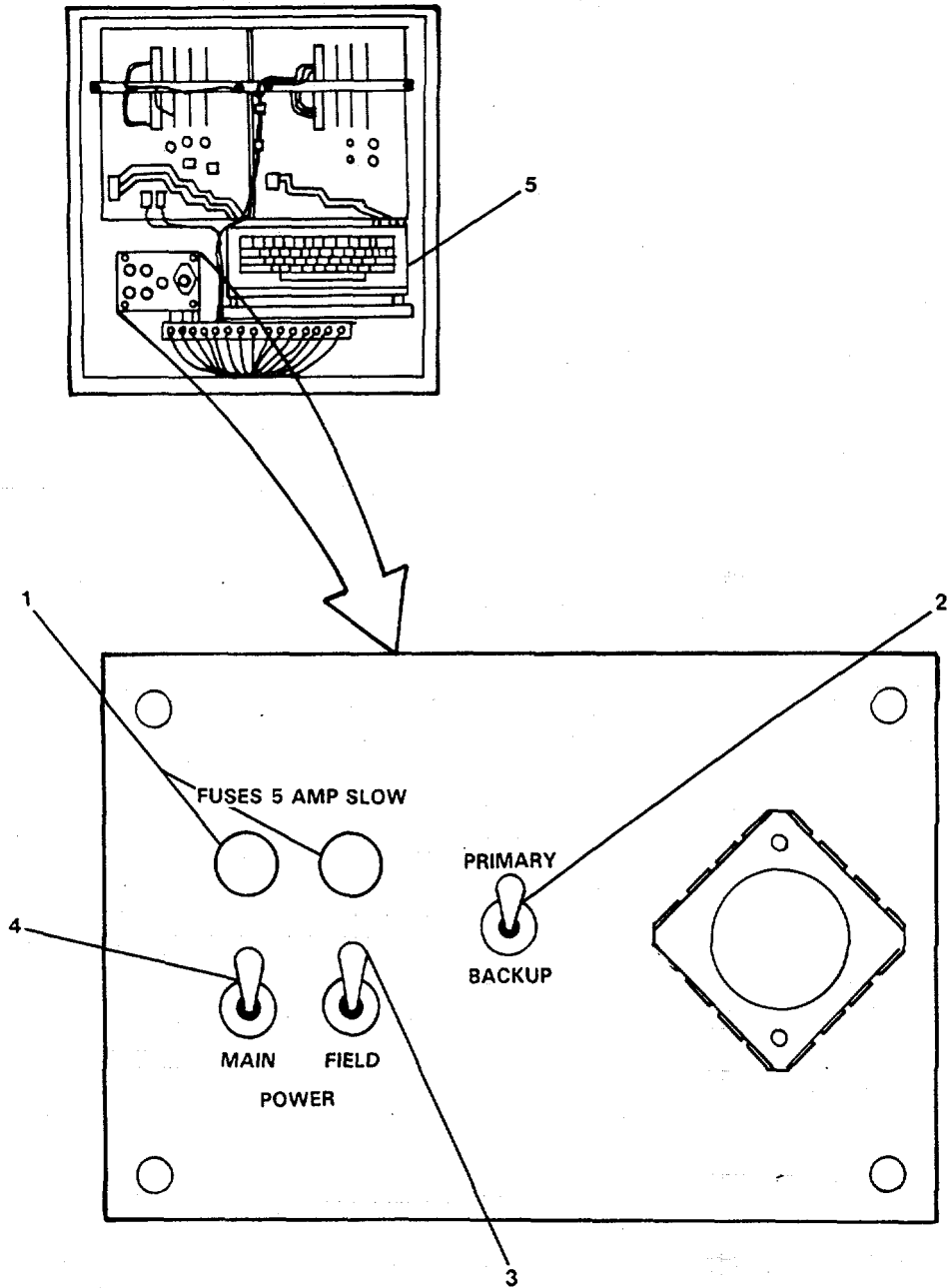

FIGURE 2-27. Engine Efficiency Panel.

Table 2-1. Description of Operator's Controls and Indicators - CONT

Key	Control or Indicator	Function
Engine Efficiency Panel (FIGURE 2-27)		
1	FUSES 5 AMP SLOW	Protects engine efficiency panel from amperage overload.
2	PRIMARY BACKUP	Selects primary or backup circuit boards for panel operation.
3	FIELD	Provides ON-OFF control of power to the remote modules
4	MAIN	<p>Provides ON-OFF control of power for the entire system and feeds power to the field power switch.</p> <p style="text-align: center;"><b>CAUTION</b></p> <p style="text-align: center;">Operator must not touch the keyboard since it is possible to erase or damage the computer program. Only contractor personnel are authorized to use the keyboard or program the computer.</p>
5	Keyboard	Used to program the computer.

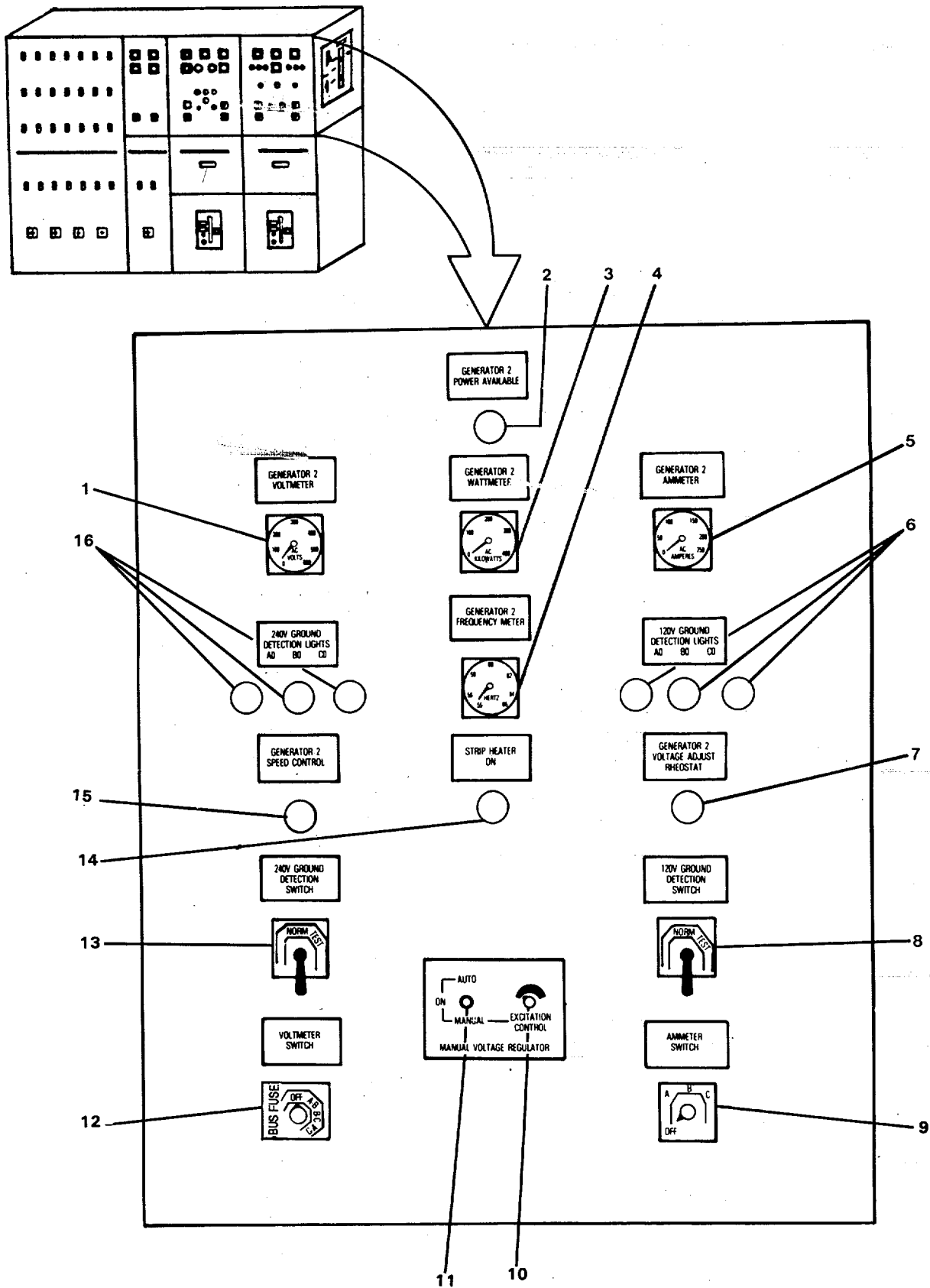

FIGURE 2-28. Main Switchboard (Sheet 1 of 7).

Table 2-1. Description of Operator's Controls and Indicators - CONT

Key	Control or Indicator	Function
Main Switchboard (FIGURE 2-28)		
1	GENERATOR 2 VOLTMETER	Indicates voltage of phase selector switch of generator No. 2.
2	GENERATOR 2 POWER AVAILABLE	White light indicates power available from generator No. 2 (white).
3	GENERATOR 2 WATTMETER	Indicates watt output of generator No. 2.
4	GENERATOR 2 FREQUENCY METER	Indicates frequency of generator No. 2.
5	GENERATOR 2 AMMETER	Indicates amperage of generator No. 2.
6	120V GROUND DETECTION LIGHTS	Indicates ground fault conditions on any one of three phases of generator No. 2 (amber).
7	GENERATOR 2 VOLTAGE ADJUST RHEOSTAT	Adjusts output of generator No. 2 for parallel operation.
8	120V GROUND DETECTION SWITCH	Tests amber lights of three phases of generator No. 2 voltage.
9	AMMETER SWITCH	Selects one of three phases of generator No. 2 displayed on AC ammeter.
10	EXCITATION CONTROL	Controls generator exciter manually.
11	AUTO OFF MANUAL	Controls automatic or manual exciter operation.
12	VOLTMETER SWITCH	Selects A-B, B-C, C-A, or BUS A-B phase of generator No. 2 to be displayed on AC voltmeter.
13	240V GROUND DETECTION SWITCH	Tests amber lights of three phases of generator No. 2 voltage.

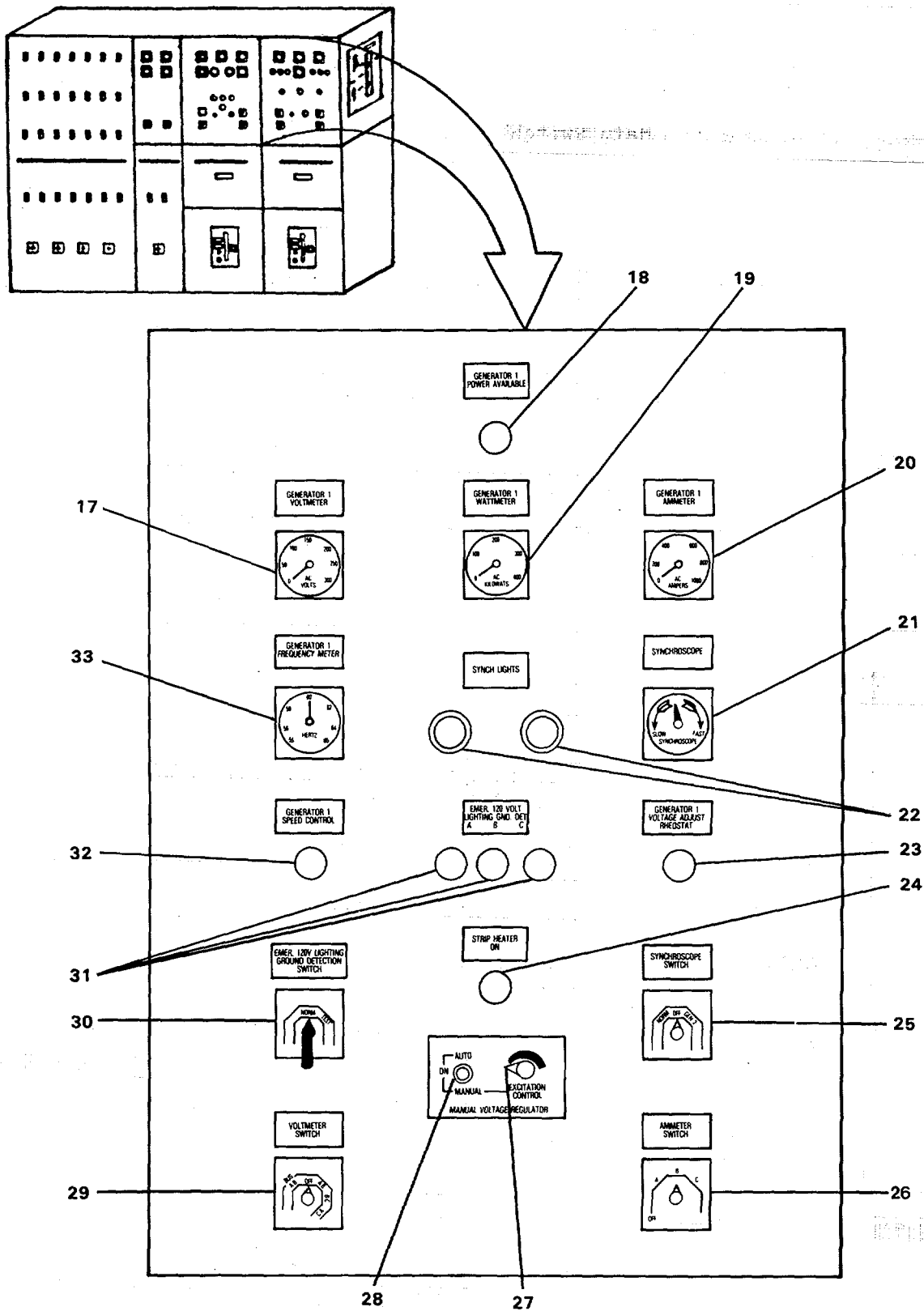

FIGURE 2-28. Main Switchboard (Sheet 2 of 7).

Table 2-1. Description of Operator's Controls and Indicators - CONT

Key	Control or Indicator	Function
Main Switchboard (FIGURE 2-28) - Continued		
14	STRIP HEATER ON	Indicates that strip heater is activated (amber).
15	GENERATOR 2 SPEED CONTROL	Controls speed of diesel engine driving generator No. 2.
16	240V GROUND DETECTION LIGHTS	Indicates ground fault conditions on any one of three phases of generator No. 2. (amber).
17	GENERATOR 1 VOLTMETER	Indicates voltage of phase selector switch of generator No. 1.
18	GENERATOR 1 POWER AVAILABLE	Indicates power available from generator No. 1 (white).
19	GENERATOR 1 WATTMETER	Indicates generator No. 1 watt output.
20	GENERATOR 1 AMMETER	Indicates amperage of generator No. 1.
21	SYNCHROSCOPE	Indicates status of frequency synchronization with generator No. 2. Meter indicates whether frequency is fast or slow.
22	SYNCH. LIGHTS	Steady lights indicate that generator No. 1 is in frequency synchronization with generator No. 2.
23	GENERATOR 1 VOLTAGE ADJUST RHEOSTAT	Adjusts output of generator No. 1 for parallel operation.
24	STRIP HEATER ON	Indicates that strip heater is activated (amber).
25	SYNCHROSCOPE SWITCH	Selects NORMAL, OFF, or GENERATOR NO. 2 mode for synchronization.
26	AMMETER SWITCH	Selects one of three phases of generator No. 1 to be displayed on AC ammeter.
27	EXCITATION CONTROL	Controls generator exciter manually.

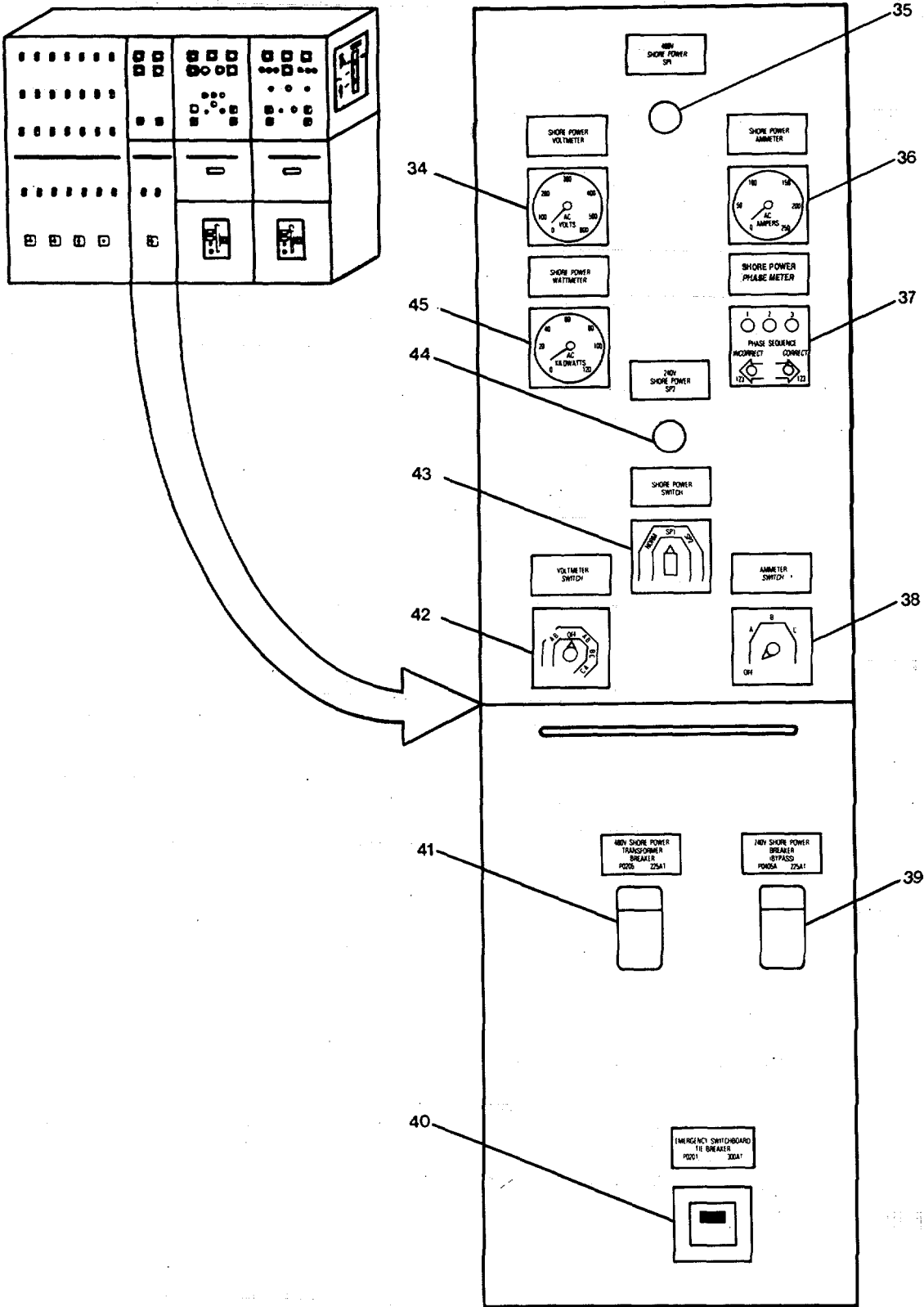

FIGURE 2-28. Main Switchboard (Sheet 3 of 7).

Table 2-1. Description of Operator's Controls and Indicators - CONT

Key	Control or Indicator	Function
Main Switchboard (FIGURE 2-28) - Continued		
28	AUTO OFF MANUAL	Controls automatic or manual exciter operation.
29	VOLTMETER SWITCH	Selects A-B, B-C, C-A, or BUS A-B phase of generator No. 1 to be displayed on AC voltmeter.
30	EMER 120V LIGHTING GROUND DETECTION SWITCH	Tests amber lights of three phases of emergency 120V lighting system.
31	EMER 120V LIGHTING GROUND DETECTION	Indicates ground fault conditions on any one of three phases of emergency lighting system (amber).
32	GENERATOR 1 SPEED CONTROL	Controls speed of diesel engine driving generator No. 1.
33	GENERATOR 1 FREQUENCY METER	Indicates frequency of generator No. 1.
34	SHORE POWER VOLTMETER	Indicates voltage of phase selector switch of shore power.
35	480V SHORE POWER AVAILABLE SP1	Indicates 480V shore power is available (blue).
36	SHORE POWER AMMETER	Indicates amperage of shore power phase selector switch.
37	SHORE POWER PHASE METER	Indicates phase sequence of shore power.
38	AMMETER SWITCH	Selects one of three phases of shore power displayed on AC ammeter.
39	240V SHORE POWER BREAKER (BYPASS)	Protects 240V shore power circuit from amperage overload.
	PO405A	225AT



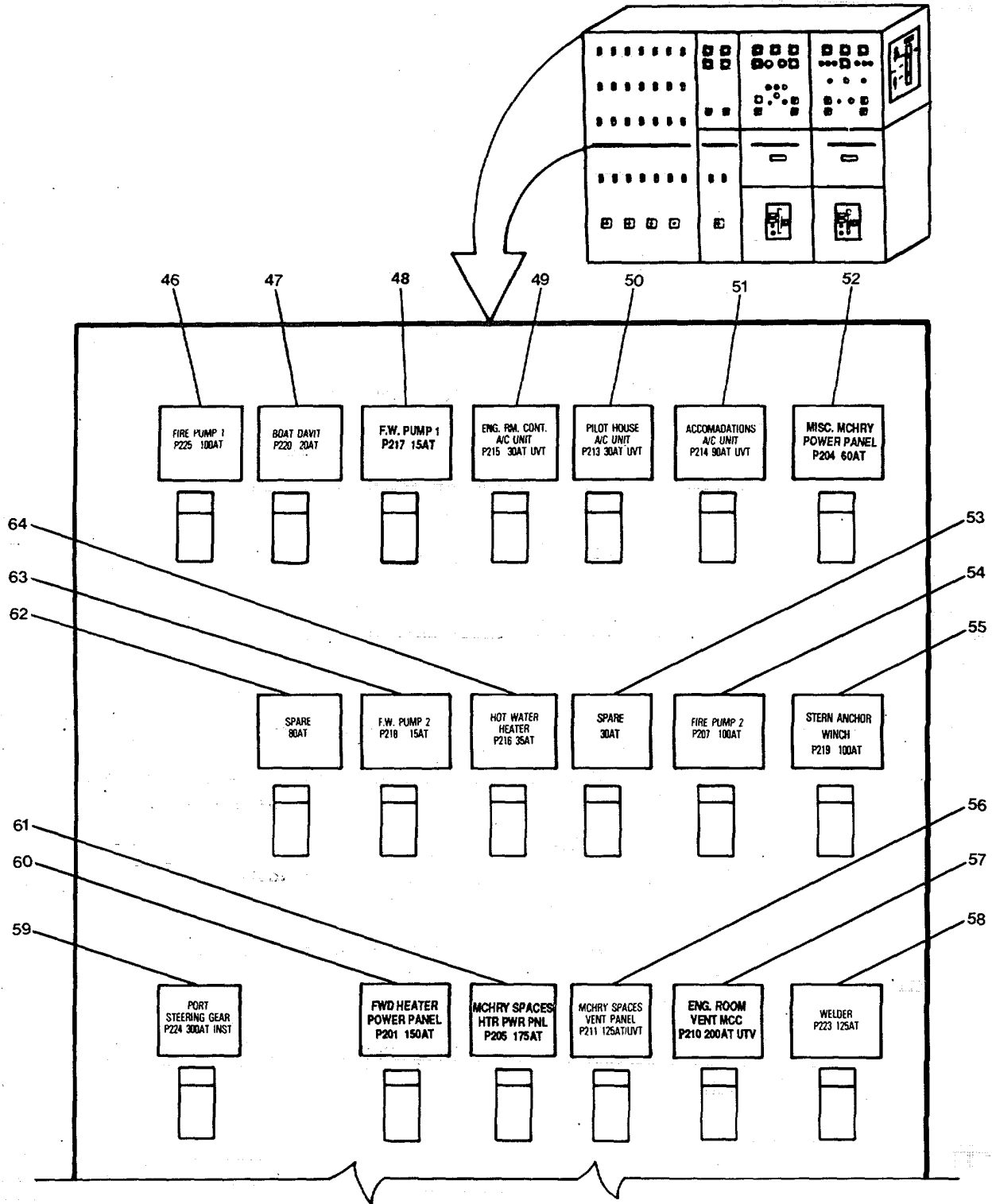

FIGURE 2-28. Main Switchboard (Sheet 4 of 7).

Table 2-1. Description of Operator's Controls and Indicators - CONT

Key	Control or Indicator	Function
Main Switchboard (FIGURE 2-28) - Continued		
40	EMERGENCY SWITCHBOARD TIE BREAKER P201 300AT	Protects Power Panel P201 from amperage overload.
41	480V SHORE POWER TRANSFORMER BREAKER P0205 225AT	Protects Power Panel P0205 from amperage overload.
42	VOLTMETER SWITCH	Selects A-B, B-C, or C-A phase of shore power to be displayed on the voltmeter.
43	SHORE POWER SWITCH	Selects normal, shore power 1, or shore power 2.
44	240V SHORE POWER AVAILABLE SP2	Indicates 240V shore power is available (blue).
45	SHORE POWER WATTMETER	Indicates shore power wattage output.
46	FIRE PUMP 1 P225 100AT	Protects fire pump No. 1 from amperage overload.
47	BOAT DAVIT P220 20AT	Protects boat crane from amperage overload.
48	F.W. PUMP 1 P217 15AT	Protects fresh water pump No. 1 from amperage overload.
49	ENG. RM. CONT. A/C UNIT P215 30AT UVT	Protects engine room operating station A/C unit from amperage overload.
50	PILOT HOUSE A/C UNIT P213 30AT UVT	Protects pilothouse A/C unit from amperage overload.
51	ACCOMMODATIONS A/C UNIT P214 90AT UVT	Protects accommodations A/C unit from amperage overload.

Table 2-1. Description of Operator's Controls and Indicators - CONT

Key	Control or Indicator	Function
Main Switchboard (FIGURE 2-28) - Continued		
52	MISC. MCHRY POWER PANEL P204 60AT	Protects power panel P204 from amperage overload.
53	SPARE 30AT	Spare circuit breaker if additional distribution is required with 30 ampere circuit protection.
54	FIRE PUMP 2 P207 100AT	Protects fire pump No. 2 from amperage overload.
55	STERN ANCHOR WINCH P219 100AT	Protects stern anchor winch from amperage overload.
56	MCHRY SPACES VENT PANEL P211 125AT/UVT	Protects power panel P211 with automatic trip circuit breaker with under-voltage trip protection.
57	ENG. ROOM VENT MCC P210 200AT/UTV	Protects power panel P210 with automatic trip circuit breaker with under-voltage trip protection.
58	WELDER P223(1) 125AT	Protects power panel P223(1) from amperage overload.
59	PORT STEERING GEAR P224 30ATINS	Protects port steering gear-with instantaneous magnetic trip circuit protector.
60	FWD. HEATER POWER PANEL P201 150AT	Protects power panel P201 from amperage overload.
61	MCHRY SPACES HTR PWR PNL P203 175AT	Protects power panel P203 from amperage overload.
62	SPARE 80AT	Spare circuit breaker if additional distribution is required with 80-ampere circuit protection.
63	F.W. PUMP 2 P218 15AT	Protects fresh water pump No. 2 from amperage overload.
64	HOT WATER HTR P216 35AT	Protects hot water heater from amperage overload.

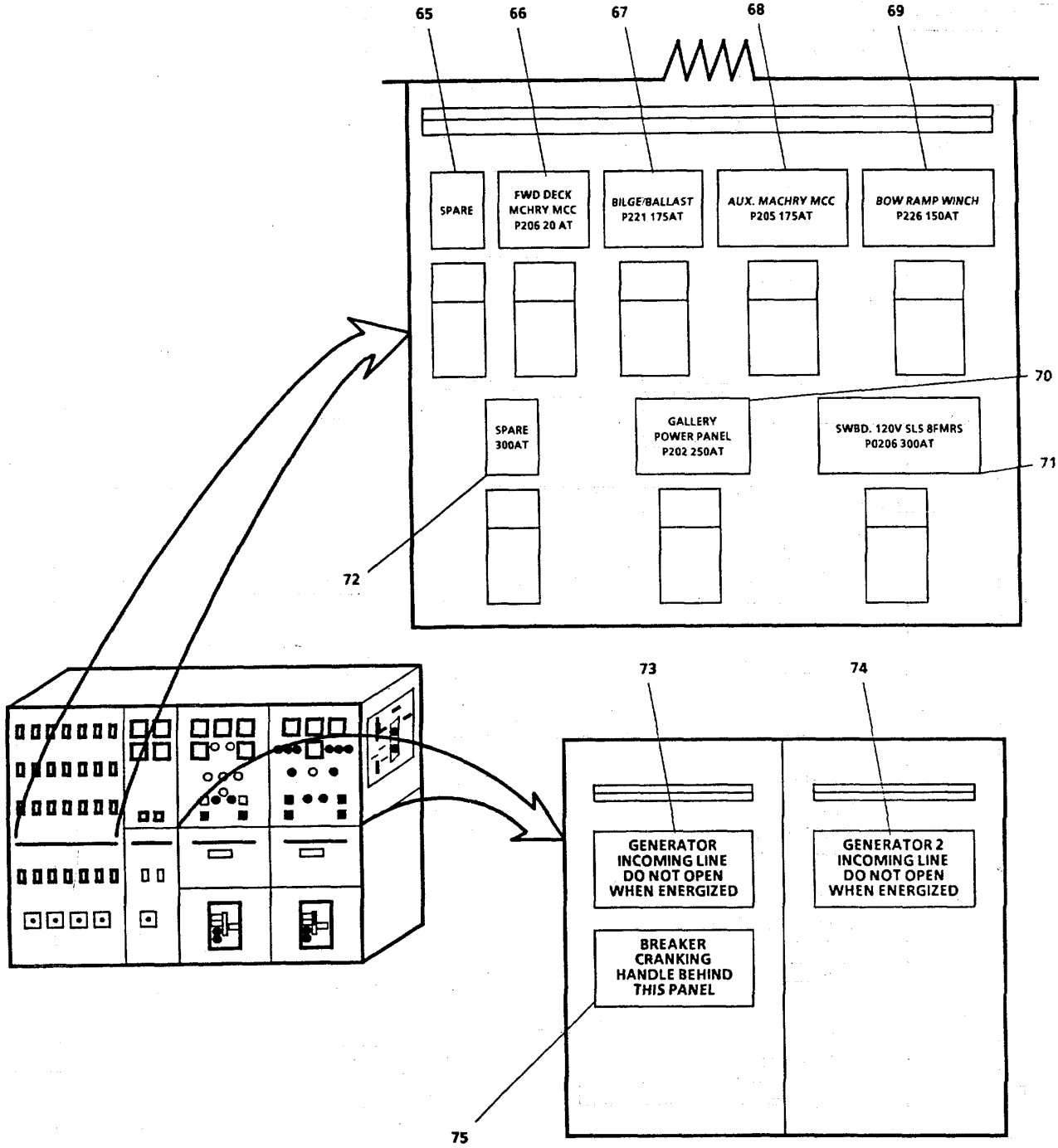

FIGURE 2-28. Main Switchboard (Sheet 5 of 7).

Table 2-1. Description of Operator's Controls and Indicators - CONT

Key	Control or Indicator	Function
Main Switchboard (FIGURE 2-28) - Continued		
65	SPARE 100AT	Spare circuit breaker if additional distribution is required with 100-ampere circuit protection.
66	FWD DECK MCHRY MCC P206 200AT	Protects Power Panel P206 from amperage overload.
67	BILGE/BALLAST PUMP P221 175AT	Protects bilge/ballast pump from amperage overload.
68	AUX. MCHRY MCC P205 175AT	Protects Power Panel P205 from amperage overload.
69	BOW RAMP WINCH P226 150AT	Protects bow ramp winch from amperage overload.
70	GALLEY POWER PANEL P202 250AT	Protects Power Panel P202 from amperage overload.
71	SWBD 120V S/S XFMR P0206 300AT	Protects Power Panel P0206 from amperage overload.
72	SPARE 300AT	Spare circuit breaker if additional distribution is required with 300-ampere circuit protection.
73	GENERATOR 1 INCOMING LINE DO NOT OPEN WHEN ENERGIZED	Red and white warning placard.
74	GENERATOR 2 INCOMING LINE DO NOT OPEN WHEN ENERGIZED	Red and white warning placard.
75	BREAKER CRANKING HANDLE BEHIND THIS PANEL	Provides location of breaker cranking handle.

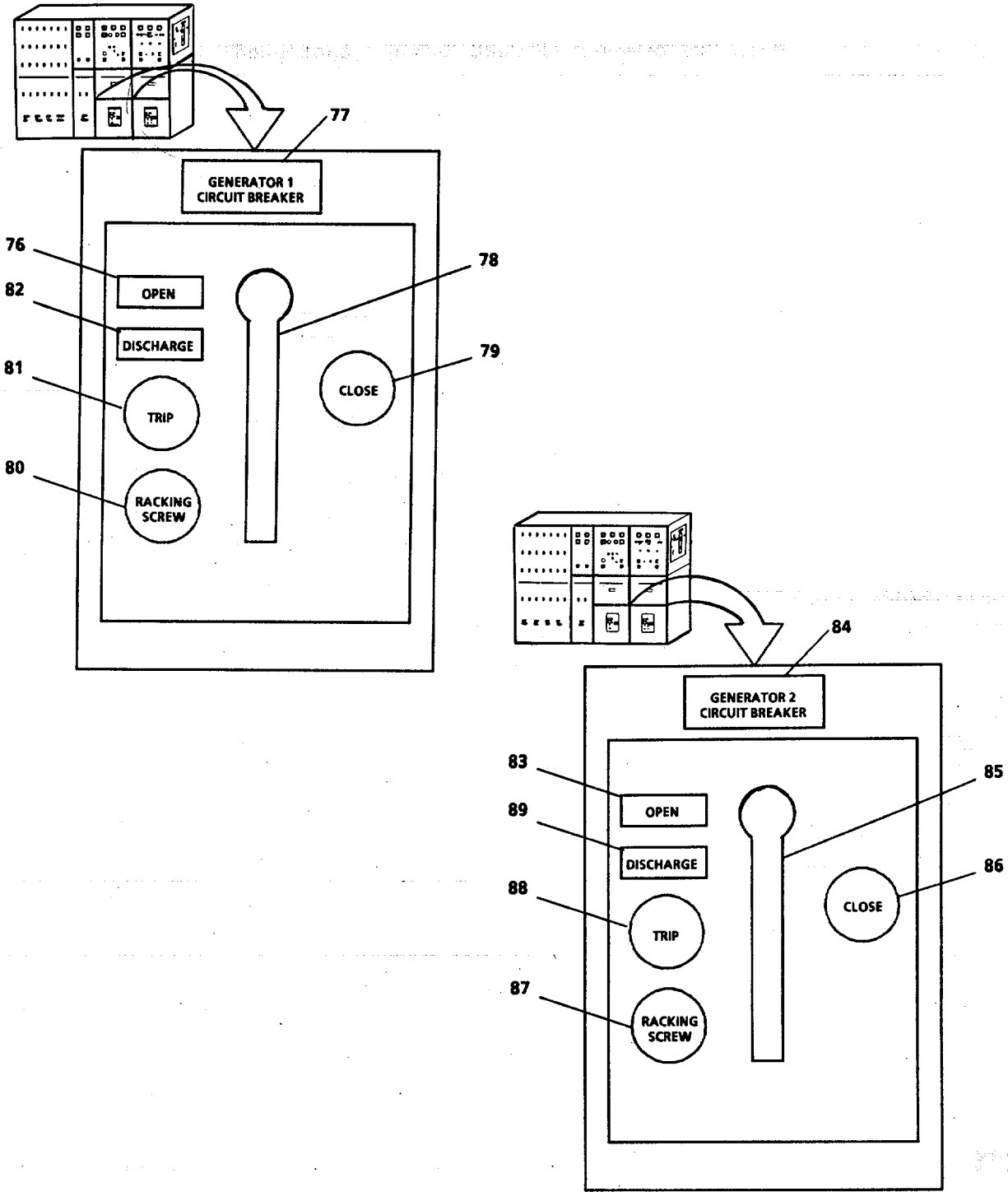

FIGURE 2-28. Main Switchboard (Sheet 6 of 7).

Table 2-1. Description of Operator's Controls and Indicators - CONT

Key	Control or Indicator	Function
Main Switchboard (FIGURE 2-28) - Continued		
76	OPEN                      CLOSED	Indicates circuit breaker open (green). Indicates circuit breaker closed (red).
77	GENERATOR 1 CIRCUIT BREAKER	Panel nameplate.
78	CIRCUIT BREAKER LOADING ARM	Charges spring for circuit breaker contacts.
79	CLOSE	Pushbutton to release breaker closing spring.
80	RACKING SCREW	Door slides to allow breaker cranking end to engage racking screw.
81	TRIP	Pushbutton to open circuit breaker.
82	DISCHARGE	Indicates circuit breaker spring is charged or discharged.
83	OPEN                      CLOSED	Indicates circuit breaker open (green). Indicates circuit breaker closed (red).
84	GENERATOR 2 CIRCUIT BREAKER	Panel nameplate.
85	CIRCUIT BREAKER LOADING ARM	Charges spring for circuit breaker contacts.
86	CLOSE	Pushbutton to release breaker closing spring.
87	RACKING SCREW	Door slides to allow breaker cranking end to engage racking screw.
88	TRIP	Pushbutton to open circuit breaker.
89	DISCHARGE	Indicates circuit breaker spring is charged or discharged.
90	QTRS HEATER PANEL	Protects Power Panel P101 with automatic trip circuit breaker and under-voltage trip protection.
	P101                                      125ATUVT	

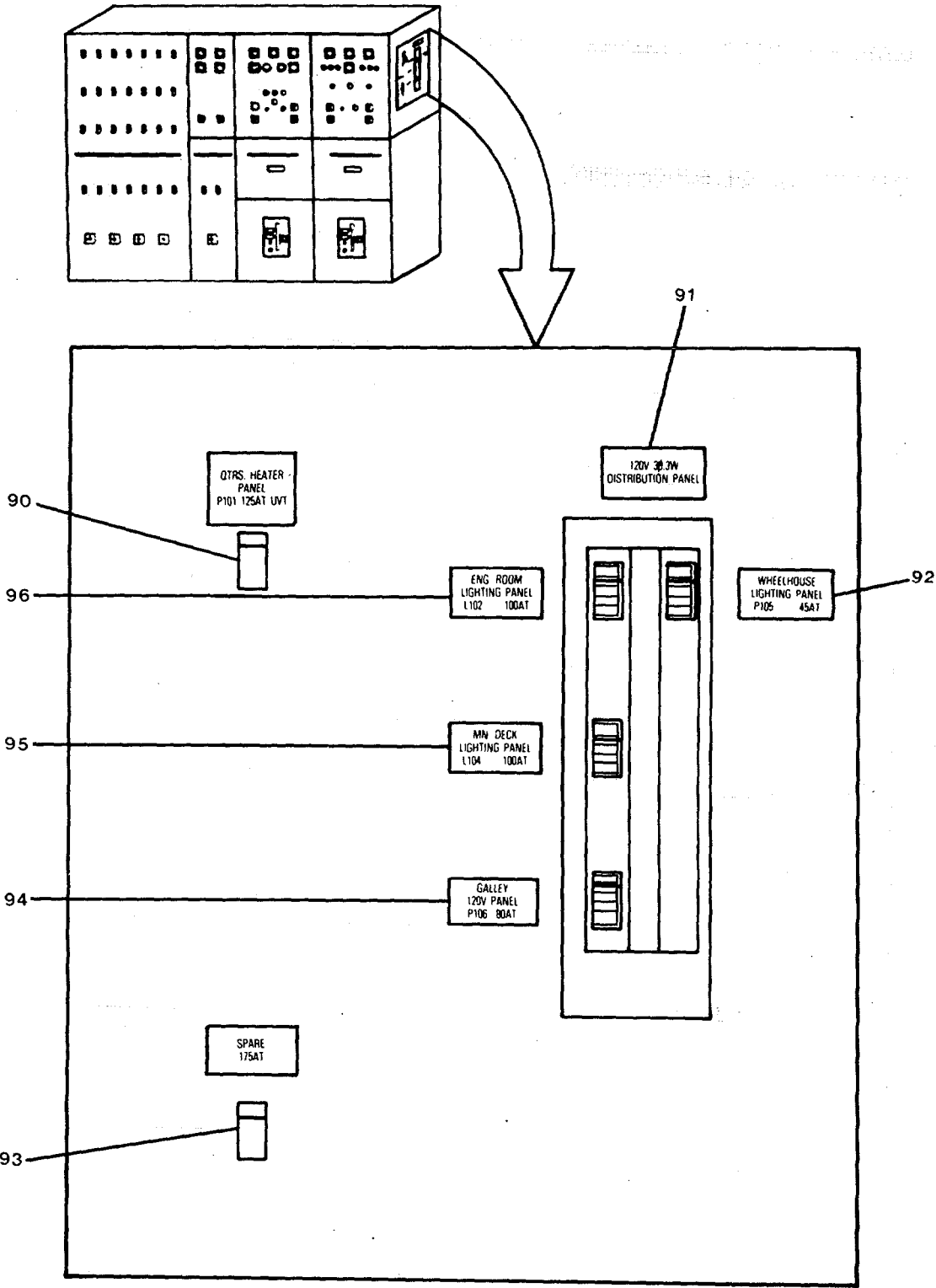

FIGURE 2-28. Main Switchboard (Sheet 7 of 7).



Table 2-1. Description of Operator's Controls and Indicators - CONT

Key	Control or Indicator	Function
Main Switchboard (FIGURE 2-28) - Continued		
91	120V 30 3W DISTRIBUTION PANEL	Panel nameplate.
92	P105 WHEELHOUSE LIGHTING PANEL 45AT	Protects Power Panel P105 with automatic trip circuit breaker.
93	SPARE	Spare circuit breaker if additional distribution is required with 125 ampere circuit protection.
94	P106 GALLEY 120V PANEL 80AT	Protects Power Panel P106 with automatic trip circuit breaker.
95	MN. DECK LIGHTING PANEL L104 100AT	Protects Lighting Panel L104 with automatic trip circuit breaker.
96	L102 ENG. ROOM LIGHTING PANEL 100AT	Protects Lighting Panel L102 with automatic trip circuit breaker.

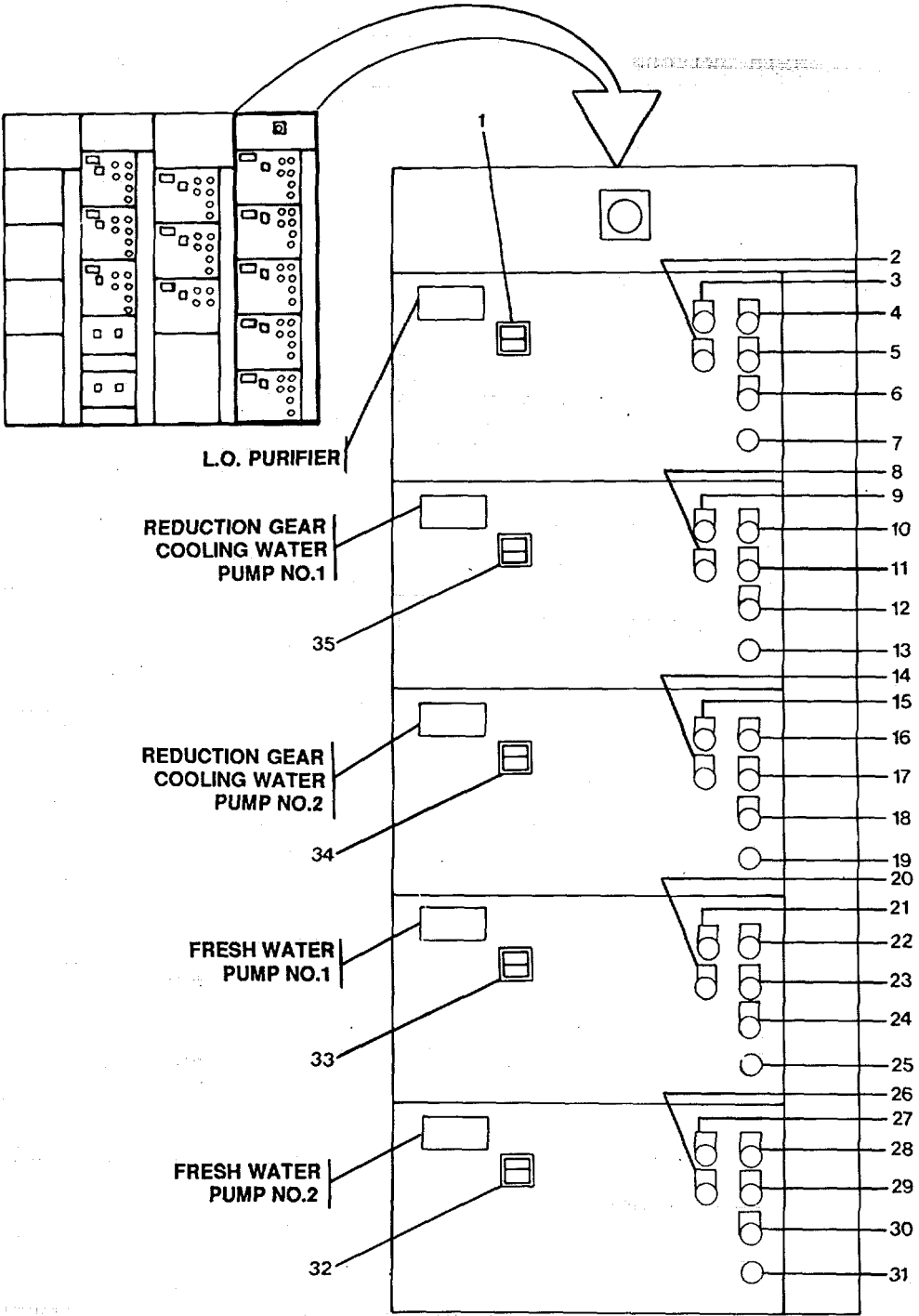

FIGURE 2-29. Auxiliary Machinery Motor Control Center (Sheet 1 of 4).

Table 2-1. Description of Operator's Controls and Indicators - CONT

Key	Control or Indicator	Function
Auxiliary Machinery Motor Control Center (FIGURE 2-29)		
1	P205-6	Protects lube oil purifier pump motor from amperage overload.
2	START	Pushbutton starts lubricating oil purifier pump.
3	MOTOR RUN	Indicates lubricating oil purifier pump operating (green).
4	MOTOR STOP	Indicates lubricating oil purifier pump stopped (white).
5	STOP	Pushbutton stops lubricating oil purifier pump.
6	EMERGENCY RUN	Pushbutton operates lubricating oil purifier pump for the time pushbutton is depressed.
7	RESET	Pushbutton resets lubricating oil purifier pump motor controller.
8	START	Pushbutton starts lubricating oil purifier pump motor control.
9	MOTOR RUN	Indicates reduction gear cooling water pump No. 1 is operating (green).
10	MOTOR STOP	Indicates reduction gear cooling water pump No. 1 is stopped (white).
11	STOP	Pushbutton stops reduction gear cooling water pump No. 1.
12	EMERGENCY RUN	Pushbutton operates reduction gear cooling water pump No. 1 for the time pushbutton is depressed.
13	RESET	Pushbutton resets reduction gear cooling water Pump No. 1 motor controller.
14	START	Pushbutton starts reduction gear cooling water pump No. 2.

Table 2-1. Description of Operator's Controls and Indicators - CONT

Key	Control or Indicator	Function
Auxiliary Machinery Motor Control Center (FIGURE 2-29) - Continued		
15	MOTOR RUN	Indicates reduction gear cooling water pump No. 2 is operating (green).
16	MOTOR STOP	Indicates reduction gear cooling water pump No. 2 is stopped (white).
17	STOP	Pushbutton stops reduction gear cooling water pump No. 2.
18	EMERGENCY RUN	Pushbutton operates reduction gear cooling water pump No. 2 for the time pushbutton is depressed.
19	RESET	Pushbutton resets reduction gear cooling water pump No. 2 motor controller.
20	START	Pushbutton starts freshwater Pump No. 1.
21	MOTOR RUN	Indicates freshwater pump No. 1 is operating (green).
22	MOTOR STOP	Indicates freshwater pump No. 2 is stopped (white).
23	STOP	Pushbutton stops freshwater pump No. 1.
24	EMERGENCY RUN	Pushbutton operates freshwater pump No. 1 for time pushbutton is depressed.
25	RESET	Pushbutton resets freshwater pump No. 1 motor controller.
26	START	Pushbutton starts freshwater pump No. 2.
27	MOTOR RUN	Indicates freshwater pump No. 2 is operating (green).
28	MOTOR STOP	Indicates freshwater pump No. 2 is stopped (white).
29	STOP	Pushbutton stops freshwater pump No. 2.
30	EMERGENCY RUN	Pushbutton operates freshwater pump No. 2 for time pushbutton is depressed.

Table 2-1. Description of Operator's Controls and Indicators - CONT

Key	Control or Indicator	Function
Auxiliary Machinery Motor Control Center (FIGURE 2-29) - Continued		
31	RESET	Pushbutton resets freshwater pump No. 2 motor controller.
32	P205-5	Protects freshwater pump No. 2 motor from amperage overload.
33	P205-4	Protects freshwater pump No. 1 from amperage overload.
34	P205-8	Protects reduction gear cooling water pump No. 2 from amperage overload.
35	P205-7	Protects reduction gear cooling water pump No. 1 from amperage overload.
36	P205-1	Protects auxiliary seawater pump motor from amperage overload.
37	START	Pushbutton starts auxiliary seawater cooling pump.
38	MOTOR RUN	Indicates auxiliary seawater cooling pump is operating (green).
39	MOTOR STOP	Indicates auxiliary seawater cooling pump is stopped (white).
40	STOP	Pushbutton stops auxiliary seawater cooling pump.
41	EMERGENCY RUN	Pushbutton operates auxiliary seawater cooling pump for time pushbutton is depressed.
42	RESET	Pushbutton resets auxiliary seawater cooling pump motor controller.
43	START	Pushbutton starts fuel oil transfer pump No. 1.
44	MOTOR RUN	Indicates fuel oil transfer pump No. 1 is operating (green).
45	MOTOR STOP	Indicates fuel oil transfer pump No. 1 is stopped (white).

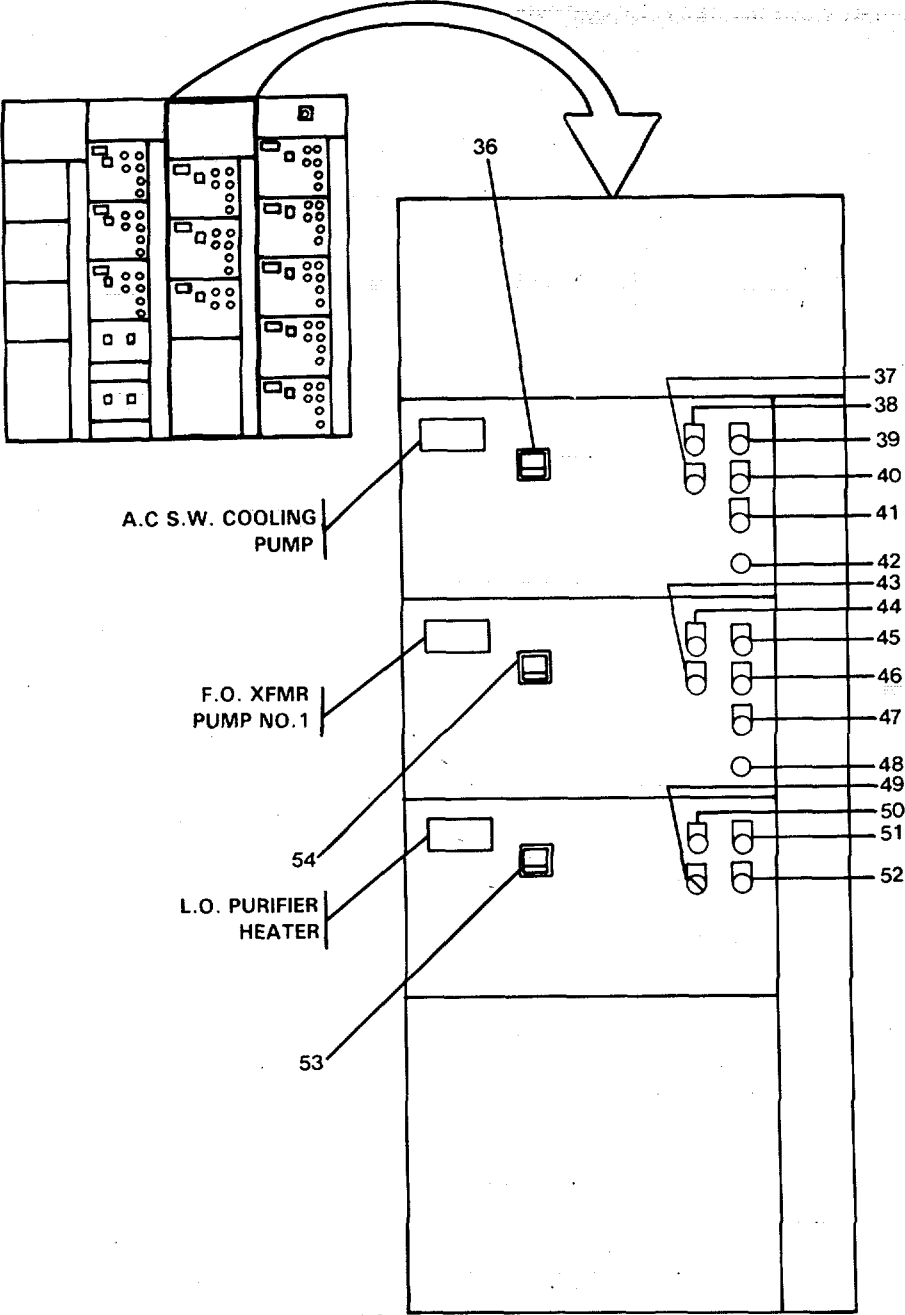

FIGURE 2-29. Auxiliary Machinery Motor Control Center (Sheet 2 of 4).

Table 2-1. Description of Operator's Controls and Indicators - CONT

Key	Control or Indicator	Function
Auxiliary Machinery Motor Control Center (FIGURE 2-29) - Continued		
46	STOP	Pushbutton stops fuel oil transfer pump No. 1.
47	EMERGENCY RUN	Pushbutton operates fuel oil transfer pump No. 1 for time pushbutton is depressed.
48	RESET	Pushbutton resets fuel oil transfer pump No. 1 motor controller.
49	START	Pushbutton starts lubricating oil purifier heater.
50	HEATER ON	Indicates lubricating oil purifier heater is ON (green).
51	HEATER OFF	Indicates lubricating oil purifier heater is OFF (white).
52	STOP	Pushbutton stops lubricating oil purifier heater.
53	P205-3	Protects lubricating oil heater from amperage overload.
54	P205-2	Protects fuel oil transfer pump motor No. 1 from amperage overload.
55	P205-10	Protects air compressor motor No. 1 from amperage overload.
56	START	Pushbutton starts air compressor No. 1.
57	MOTOR RUN	Indicates air compressor No. 1 is operating (green).
58	MOTOR STOP	Indicates air compressor No. 1 is stopped (white).
59	STOP	Pushbutton stops air compressor No. 1.
60	EMERGENCY RUN	Pushbutton operates air compressor No. 1 for time pushbutton is depressed.

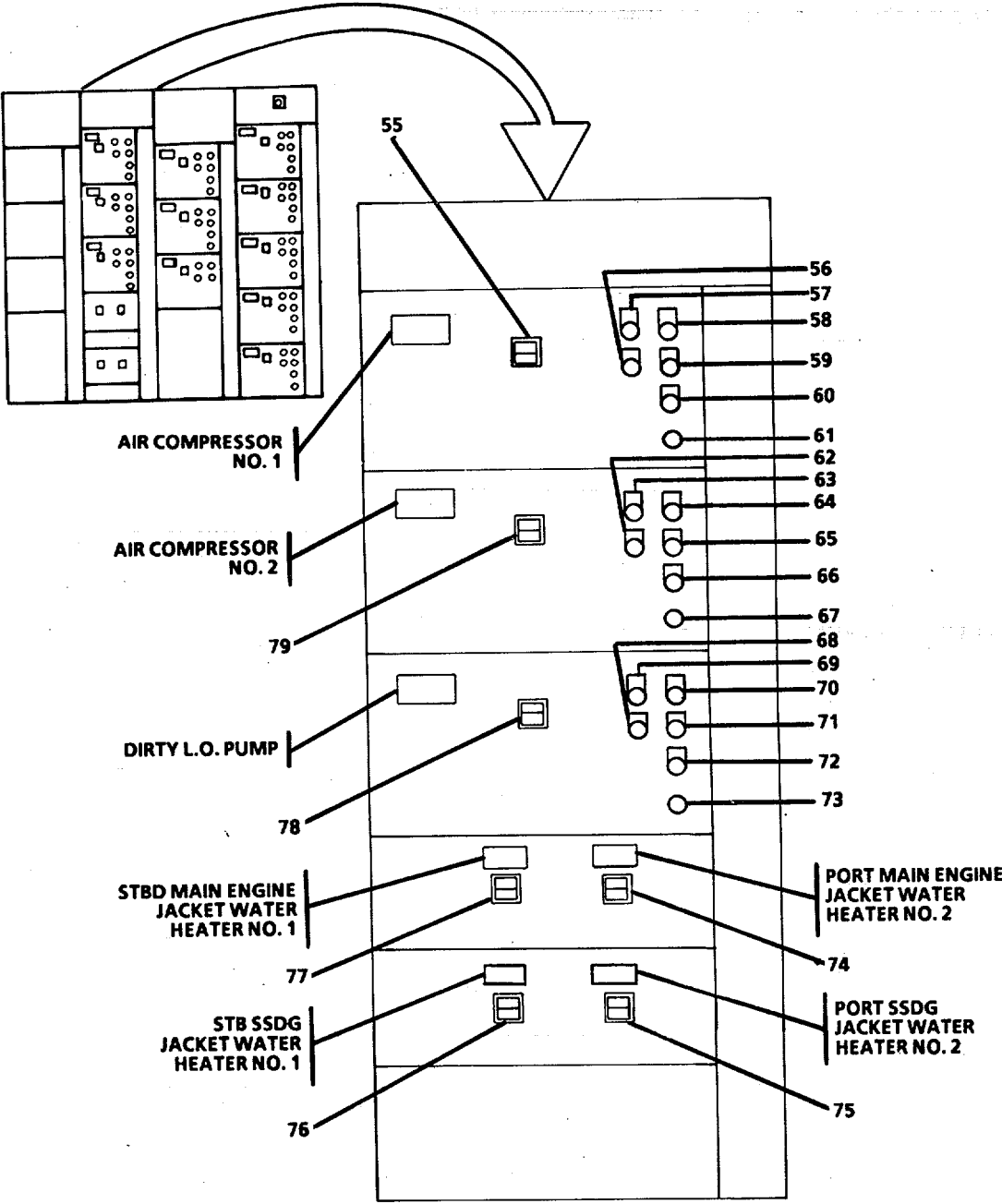

FIGURE 2-29. Auxiliary Machinery Motor control Center (Sheet 3 of 4).



Table 2-1. Description of Operator's Controls and Indicators - CONT

Key	Control or Indicator	Function
Auxiliary Machinery Motor Control Center (FIGURE 2-29) - Continued		
61	RESET	Pushbutton resets air compressor No. 1 motor controller.
62	START	Pushbutton starts air compressor No. 2.
63	MOTOR RUN	Indicates air compressor No. 2 is operating (green).
64	MOTOR STOP	Indicates air compressor No. 2 is stopped (white).
65	STOP	Pushbutton stops air compressor No. 2.
66	EMERGENCY RUN	Pushbutton operates air compressor No. 2 for time pushbutton is depressed.
67	RESET	Pushbutton resets air compressor No. 2 motor controller.
68	START	Pushbutton starts dirty lubricating oil pump.
69	MOTOR RUN	Indicates dirty lubricating oil pump is operating (green).
70	MOTOR STOP	Indicates dirty lubricating oil pump is stopped (white).
71	STOP	Pushbutton stops dirty lubricating oil pump.
72	EMERGENCY RUN	Pushbutton operates dirty lubricating oil pump for time pushbutton is depressed.
73	RESET	Pushbutton resets dirty lubricating oil pump.
74	P205-14A	Protects port main engine jacket water heater from amperage load.
75	P205-13A	Protects port ship service diesel generator jacket water heater from amperage overload.
76	P205-13B	Protects starboard ship service diesel generator jacket water heater from amperage overload.

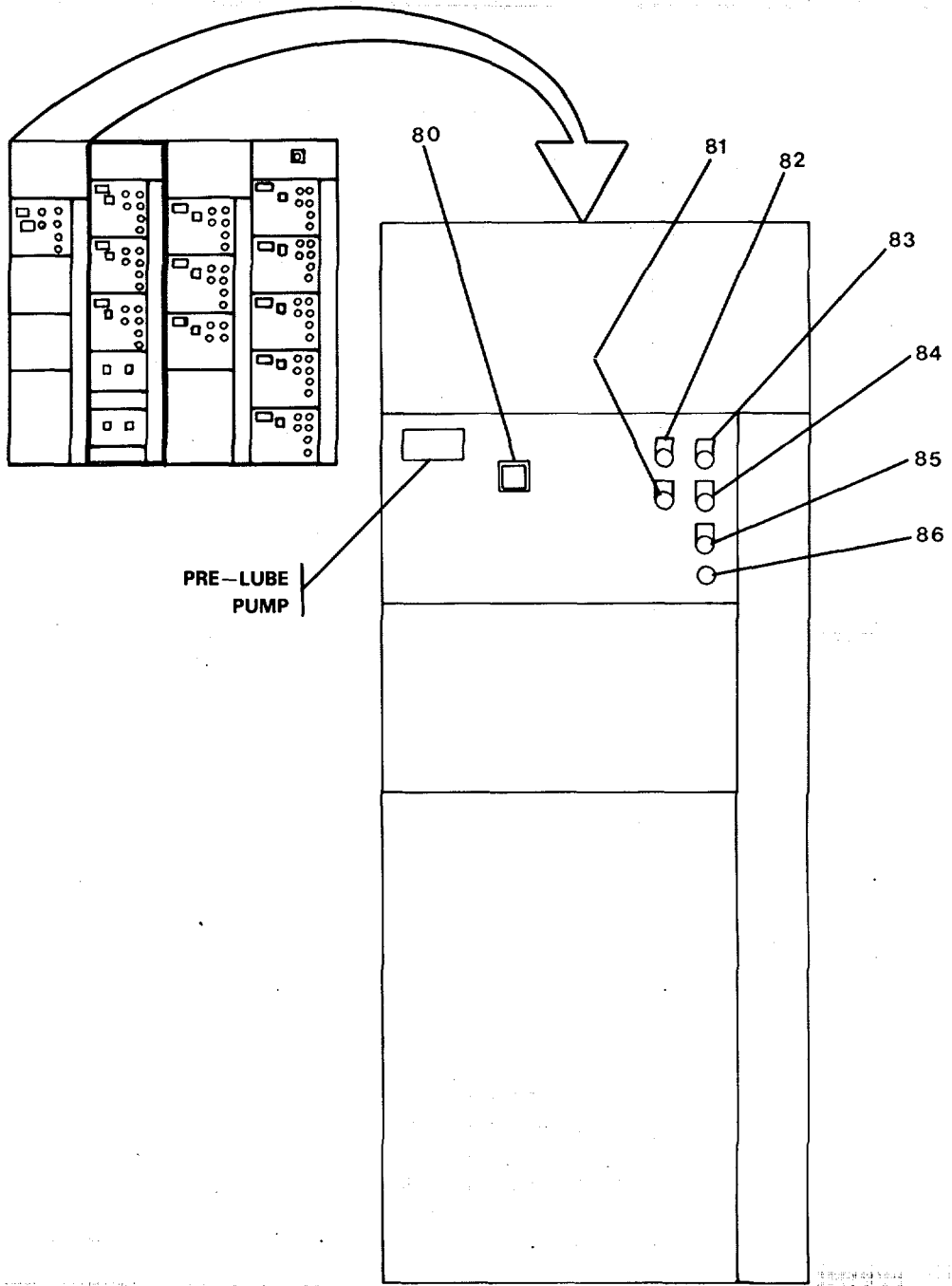

FIGURE 2-29. Auxiliary Machinery Motor Control Center (Sheet 4 of 4).

Table 2-1. Description of Operator's Controls and Indicators - CONT

Key	Control or Indicator	Function
Auxiliary Machinery Motor Control Center (FIGURE 2-29) - Continued		
77	P205-14B	Protects starboard main engine jacket water heater from amperage overload.
78	P205-12	Protects dirty lube oil pump motor from amperage overload.
79	P205-11	Protects air compressor No. 2 motor from amperage overload.
80	P205-9	Protects pre-lube pump motor from amperage overload.
81	START	Pushbutton starts pre-lube pump.
82	MOTOR RUN	Indicates pre-lube pump is operating (green).
83	MOTOR STOP	Indicates pre-lube pump is stopped (white).
84	STOP	Pushbutton stops pre-lube pump.
85	EMERGENCY RUN	Pushbutton operates pre-lube pump for the time pushbutton is depressed.
86	RESET	Pushbutton resets pre-lube motor controller.

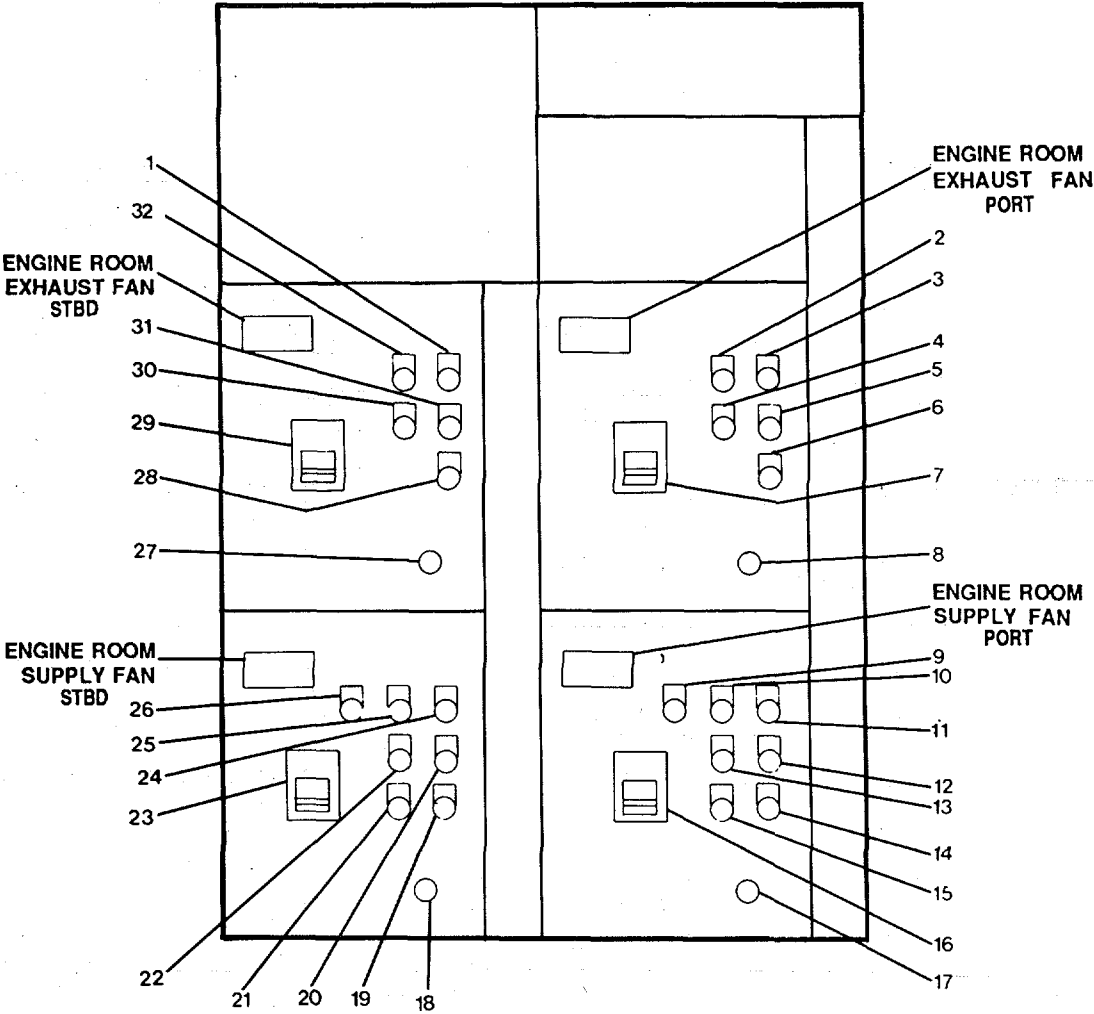

FIGURE 2-30. Engine Room Ventilation Motor Control Center.

Table 2-1. Description of Operator's Controls and Indicators - CONT

Key	Control or Indicator	Function
Engine Room Ventilation Motor Control Center (FIGURE 2-30)		
1	MOTOR STOP	Indicates engine room starboard exhaust fan is stopped (white).
2	MOTOR RUN	Indicates engine room port exhaust fan is operating (green).
3	MOTOR STOP	Indicates engine room port exhaust fan is stopped (white).
4	START	Pushbutton starts engine room port exhaust fan.
5	STOP	Pushbutton stops engine room port exhaust fan.
6	EMERGENCY RUN	Pushbutton operates engine room port exhaust fan for time pushbutton is depressed.
7	P210-3	Protects engine room port exhaust fan motor from amperage overload.
8	RESET	Pushbutton resets engine room port exhaust fan motor controller.
9	EMERGENCY RUN	Pushbutton operates engine room port supply fan for time pushbutton is depressed.
10	HIGH	Indicates engine room port supply fan is in HIGH operating mode (green).
11	HIGH	Pushbutton selects HIGH operating mode for engine room port supply fan.
12	LOW	Pushbutton selects LOW operating mode for engine room port supply fan.
13	LOW	Indicates engine room port supply fan is in LOW operating mode (green).
14	STOP	Pushbutton stops engine room port supply fan.
15	MOTOR STOP	Indicates engine room port supply fan is stopped (white).
16	P210-1	Protects engine room port supply fan from amperage overload.

Table 2-1. Description of Operator's Controls and Indicators - CONT

Key	Control or Indicator	Function
Engine Room Ventilation Motor Control Center (FIGURE 2-30) - Continued		
17	RESET	Pushbutton resets engine room port supply fan motor controller.
18	RESET	Pushbutton resets engine room starboard supply fan motor controller.
19	STOP	Pushbutton stops engine room starboard supply fan.
20	LOW	Pushbutton selects LOW operating mode for engine room starboard supply fan.
21	MOTOR STOP	Indicates engine room starboard supply fan is stopped (white).
22	LOW	Indicates engine room starboard supply fan is in LOW operating mode (green).
23	P210-2	Protects engine room starboard supply fan from amperage overload.
24	HIGH	Pushbutton selects HIGH operating mode for engine room starboard supply fan.
25	HIGH	Indicates engine room starboard supply fan is in HIGH operating mode (green).
26	EMERGENCY RUN	Pushbutton operates engine room starboard supply fan for time pushbutton is depressed.
27	RESET	Pushbutton resets engine room starboard exhaust fan motor controller.
28	EMERGENCY RUN	Pushbutton operates engine room starboard exhaust for time pushbutton is depressed.
29	P210-4	Protects engine room starboard exhaust fan from amperage overload.
30	START	Pushbutton starts engine room starboard exhaust fan.
31	STOP	Pushbutton stops engine room starboard exhaust fan.
32	MOTOR RUN	Indicates engine room exhaust fan is operating (green).

Table 2-1. Description of Operator's Controls and Indicators - CONT

Key	Control or Indicator	Function
<b>Air Compressor and Gauges (FIGURE 2-31)</b>		
1	Pressure Gauge	Indicates pressure output from reducing valve.
2	Pressure Gauge	Indicates pressure in forward storage tank.
3	Pressure Gauge	Indicates pressure in aft storage tank.
4	Pressure Gauge	Indicates pressure output from compressor pressure switch.
5	Pressure Gauge	Indicates oil pressure.

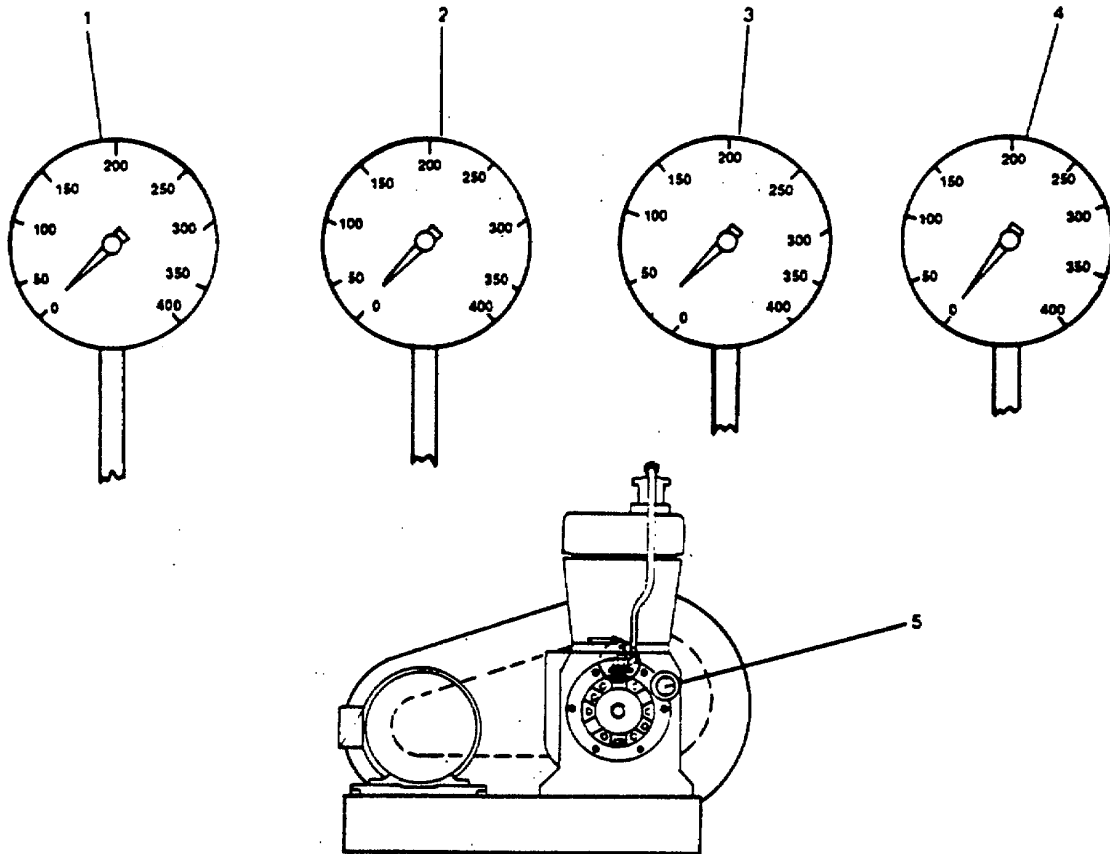

FIGURE 2-31. Air Compressor and Gauges.

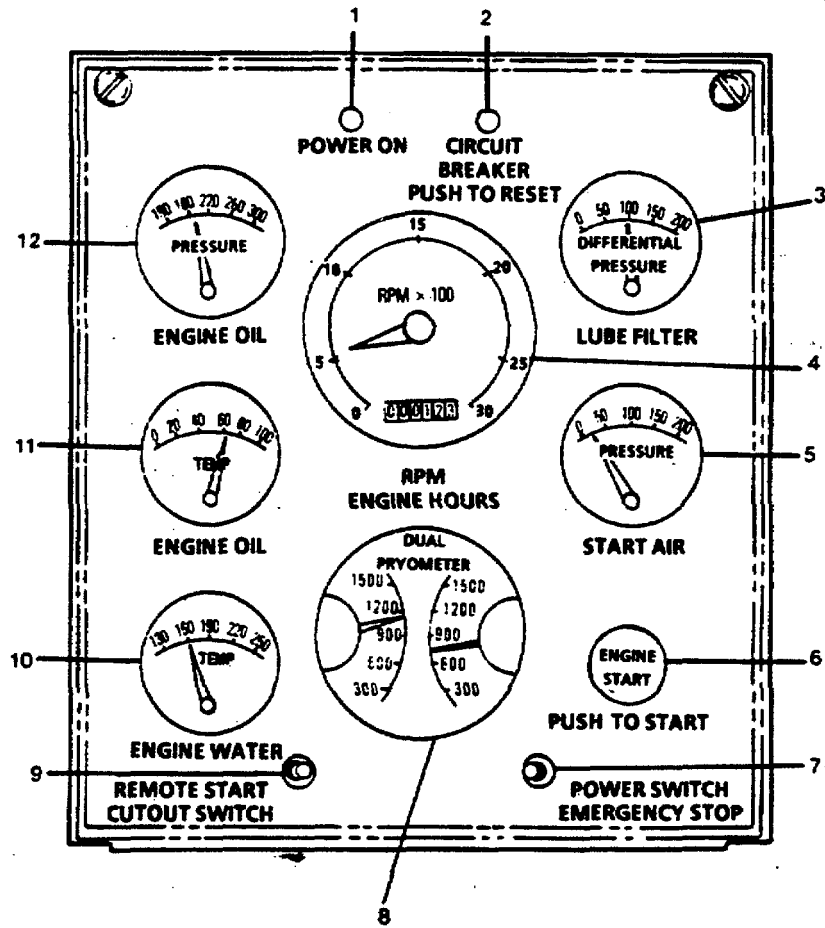

FIGURE 2-32. Main Engine Control Panel



Table 2-1. Description of Operator's Controls and Indicators - CONT

Key	Control or Indicator	Function
Main Engine Control Panel (FIGURE 2-32)		
1	POWER ON	Indicates power to control panel (green).
2	CIRCUIT BREAKER PUSH TO RESET	Protects main engine from amperage overload.
3	LUBE FILTER	Indicates pressure drop across the main engine filter.
4	RPM ENGINE HOURS	Records the number of engine operating hours and indicates engine RPM. Sounds alarm when engine overspeeds.
5	START AIR	Indicates air pressure from the air compression system. Sounds alarm with low air pressure.
6	PUSH TO START	Pushbutton starts the engine using air pressure.
7	POWER SWITCH EMERGENCY STOP	Turns on main engine control panel and stops engine.
8	DUAL PYROMETER	Measures exhaust temperature.
9	REMOTE START CUTOFF SWITCH	Eliminates start control at the pilothouse and EOS.
10	ENGINE WATER	Indicates engine water temperature. Sounds alarm when water temperature is too high.
11	ENGINE OIL	Indicates engine oil temperature at the oil pan. Sounds alarm when oil temperature is too high.
12	ENGINE OIL	Indicates engine oil pressure. Sounds alarm when oil pressure is too low.

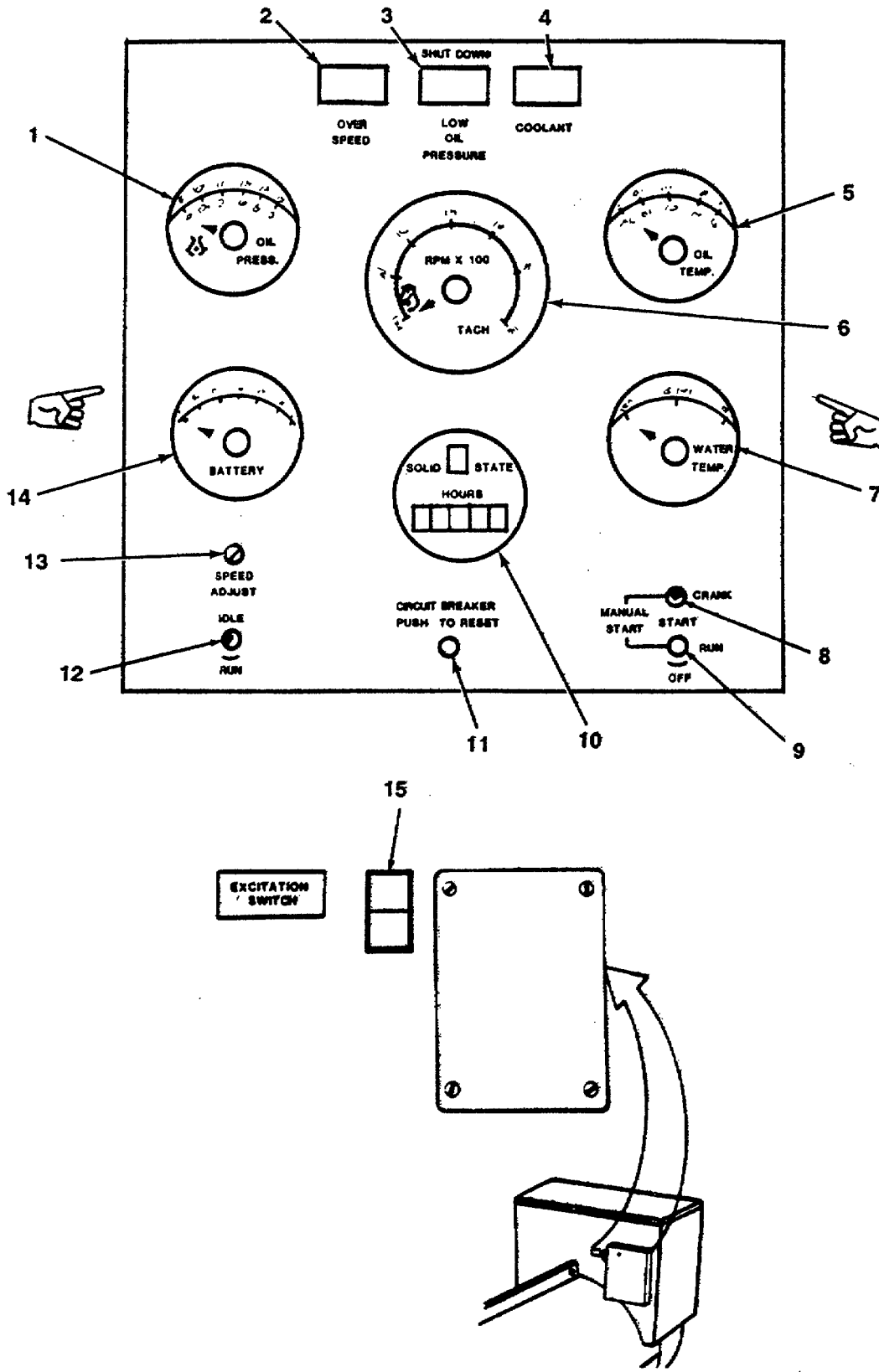

FIGURE 2-33. Ships Service Diesel Generator

**Table 2-1. Description of Operator's Controls and Indicators - CONT**

Key	Control or Indicator	Function
Ship's Service Diesel Generator 250 Kw (FIGURE 2-33)		
1	OIL PRES	Indicates engine oil pressure.
2	OVER SPEED	Indicates overspeed condition (red).
3	LOW OIL PRESSURE	Indicates low oil pressure condition (red).
4	COOLANT	Indicates high coolant temperature (red).
5	OIL TEMP	Gauge indicates engine oil temperature.
6	RPM X 100 TACH	Tachometer indicates engine RPM.
7	WATER TEMP	Gauge indicates engine water temperature.
8	CRANK	Pushbutton starts engine.
9	START RUN OFF	Controls engine mode of operation.
10	HOURS	Records actual usage time.
11	CIRCUIT BREAKER PUSH TO RESET	Resets electrical power to generator control panel.
12	IDLE RUN	Controls engine speed (toggle switch).
13	ADJUST SPEED	Provides fine speed adjustment.
14	BATTERY	Indicates battery voltage.
15	EXCITATION SWITCH	Completes the DC field to produce alternating current.

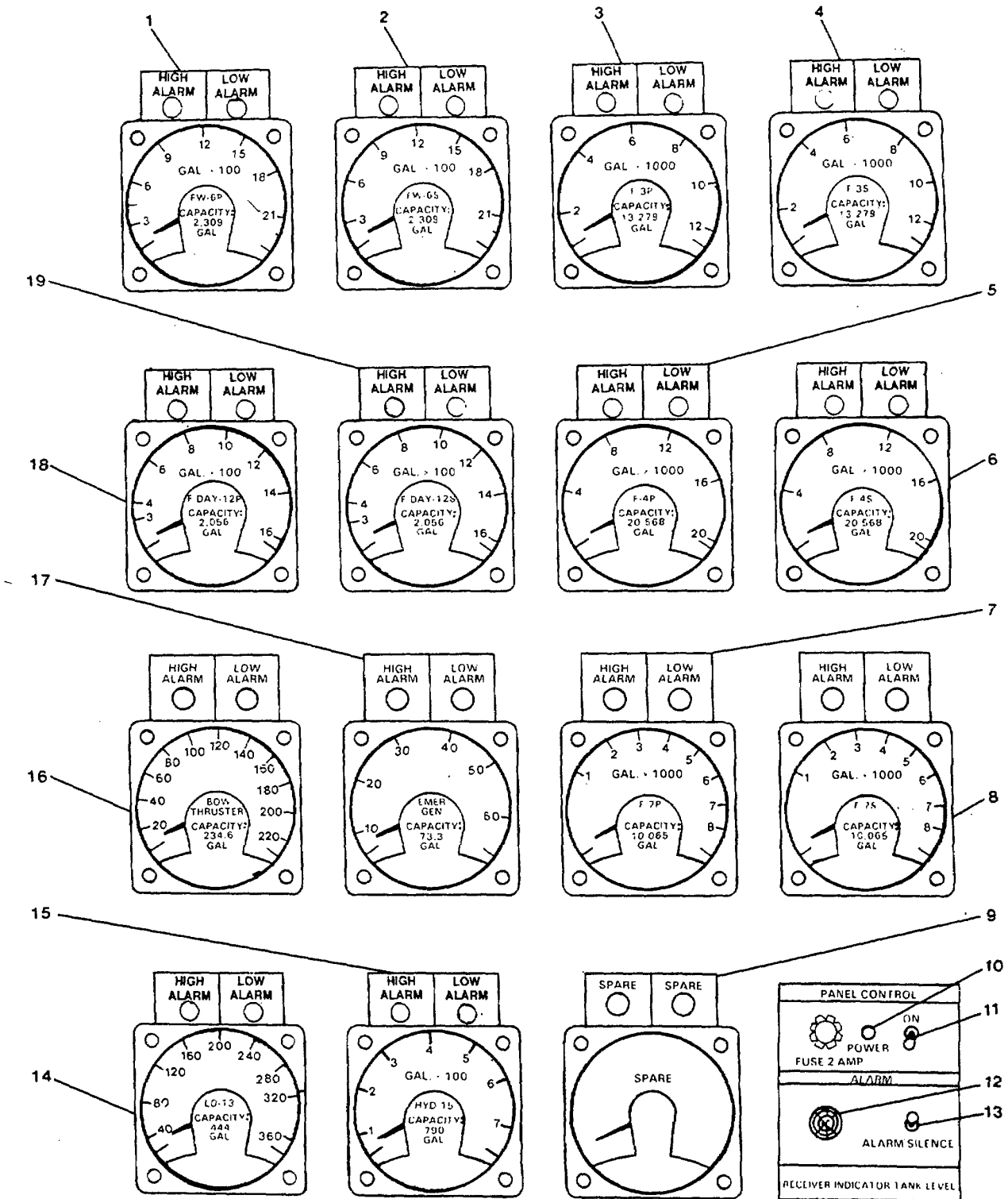

FIGURE 2-34. Tank Level Indicators (Sheet 1 of 2)

**Table 2-1. Description of Operator's Controls and Indicators - CONT**

Key	Control or Indicator	Function
Tank Level Indicators (FIGURE 2-34)		
1	FW-6P	Indicates fresh water tank 6 port eve
2	FW-6P	Indicates fresh water tank 6 STBD level.
3	FW-3P	Indicates fuel oil tank 3 port level.
4	F-3P	Indicates fuel oil tank 3 STBD level.
5	F-4P	Indicates fuel oil tank 4 port level.
6	F-4P	Indicates fuel oil tank 4 STBD level.
7	F-7P	Indicates fuel oil tank 7 port level.
8	F-7S	Indicates fuel oil tank 7 STBD level.
9	SPARE	Not used.
10	POWER	Indicates tank level indicator panel is powered (amber).
11	ON	Switch controls power to tank level indicator panel.
12	Alarm Signal	Activated by tank level indicator alarm system.
13	ALARM SILENCE	Pushbutton silences alarm signal.
14	LO-13	Indicates lubricating-oil tank level.
15	HYD-15	Indicates hydraulic oil tank level.
16	BOWTHRUSTER	Indicates bowthruster fuel oil day tank level.
17	EMER. GEN.	Indicates emergency generator fuel oil day tank level.
18	F DAY-12P	Indicates fuel oil day tank 12 port level.
19	F DAY-12S	Indicates fuel oil day tank 12 STBD level.

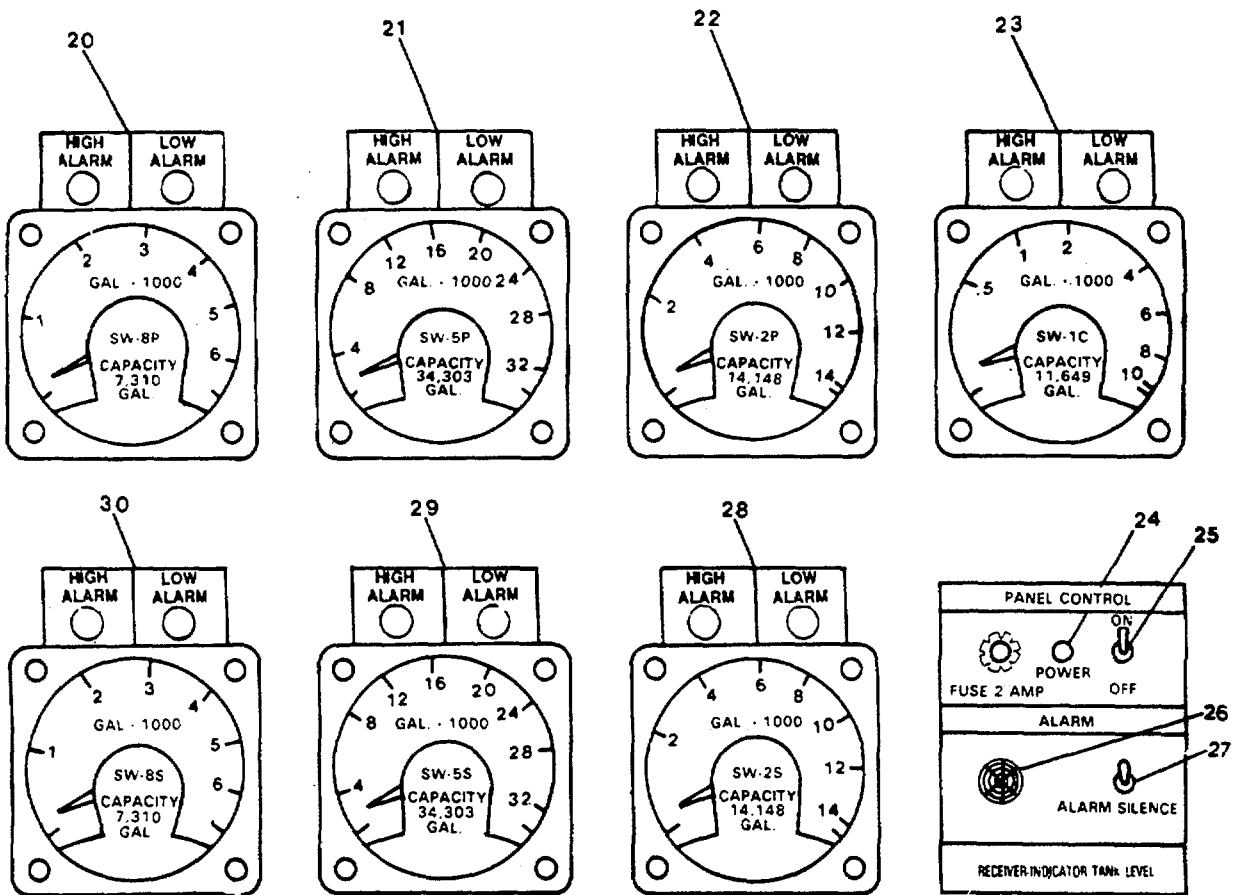

FIGURE 2-34. Tank Level Indicators (Sheet 2 of 2)

**Table 2-1. Description of Operator's Controls and Indicators - CONT**

Key	Control or Indicator	Function
Tank Level Indicators (FIGURE 2-34) - Continued		
20	SW-8P	Indicates sea water ballast tank 8 port level.
21	SW-5P	Indicates sea water ballast tank 5 port level.
22	SW-2P	Indicates sea water ballast tank 2 port level.
23	SW-1C	Indicates sea water ballast tank 1 center level.
24	POWER	Indicates tank level indicator panel is powered (amber).
25	ON	Switch controls power to tank level indicator panel.
26	Alarm Signal	Activated by tank level indicator alarm system.
27	ALARM SILENCE	Pushbutton silences alarm signal.
28	SW-2S	Indicates sea water ballast tank 2 STBD level.
29	SW-5S	Indicates sea water ballast tank 5 STBD level.
30	SW-8S	Indicates sea water ballast tank 8 STBD level.

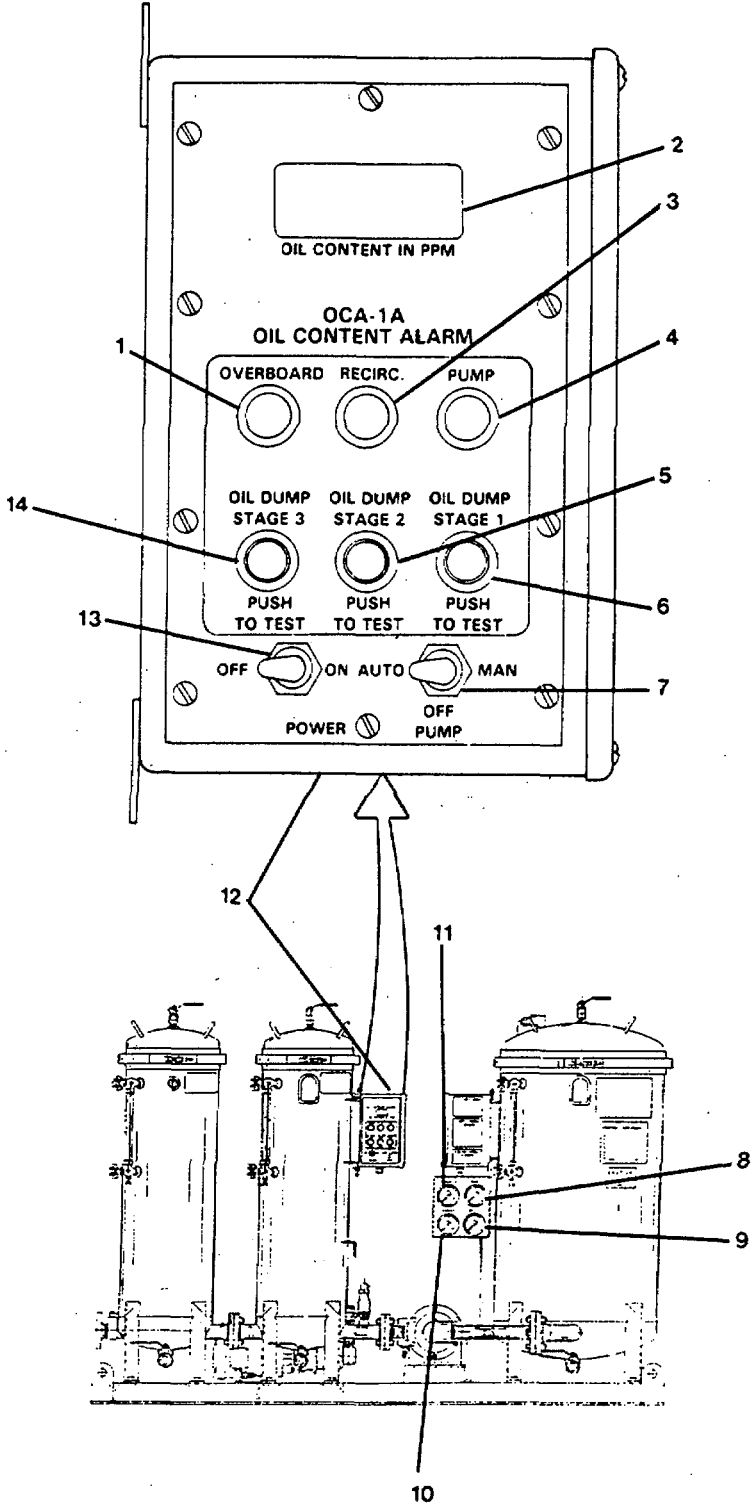

FIGURE 2-35. Oil-Water Separator.



Table 2-1. Description of Operator's Controls and Indicators - CONT

Key	Control or Indicator	Function
Oil-Water Separator (FIGURE 2-35)		
1	OVERBOARD	Indicates discharge of processed water through the water discharge valve (green).
2	OIL CONTENT IN PPM	Indicates contamination level of oil in processed fluid measured in parts per million (PPM).
3	RECIRC.	Indicates recirculation of fluid through the system (red).
4	PUMP	Indicates activation of supply pump (white).
5	OIL DUMP STAGE 2	Indicates discharge of oil from second stage (amber).
6	OIL DUMP STAGE 1	Indicates discharge of oil from first stage (amber).
7	AUTO-OFF-MAN PUMP	Water pump motor and control switch for oil level sensors, displays, and solenoid operated valves.
8	1ST STAGE	Displays internal vacuum reading of first stage separator in inches Hg.
9	3RD STAGE	Displays fluid pressure at inlet of third stage separator.
10	OUTLET	Displays fluid pressure at outlet of third stage separator.
11	2ND STAGE	Displays fluid pressure at inlet of second stage separator.
12	Control Module	Provides display and system status control.
13	OFF-ON-POWER	Provides 115 Vac input power control.
14	OIL DUMP STAGE 3	Indicates discharge of oil from third stage (amber).

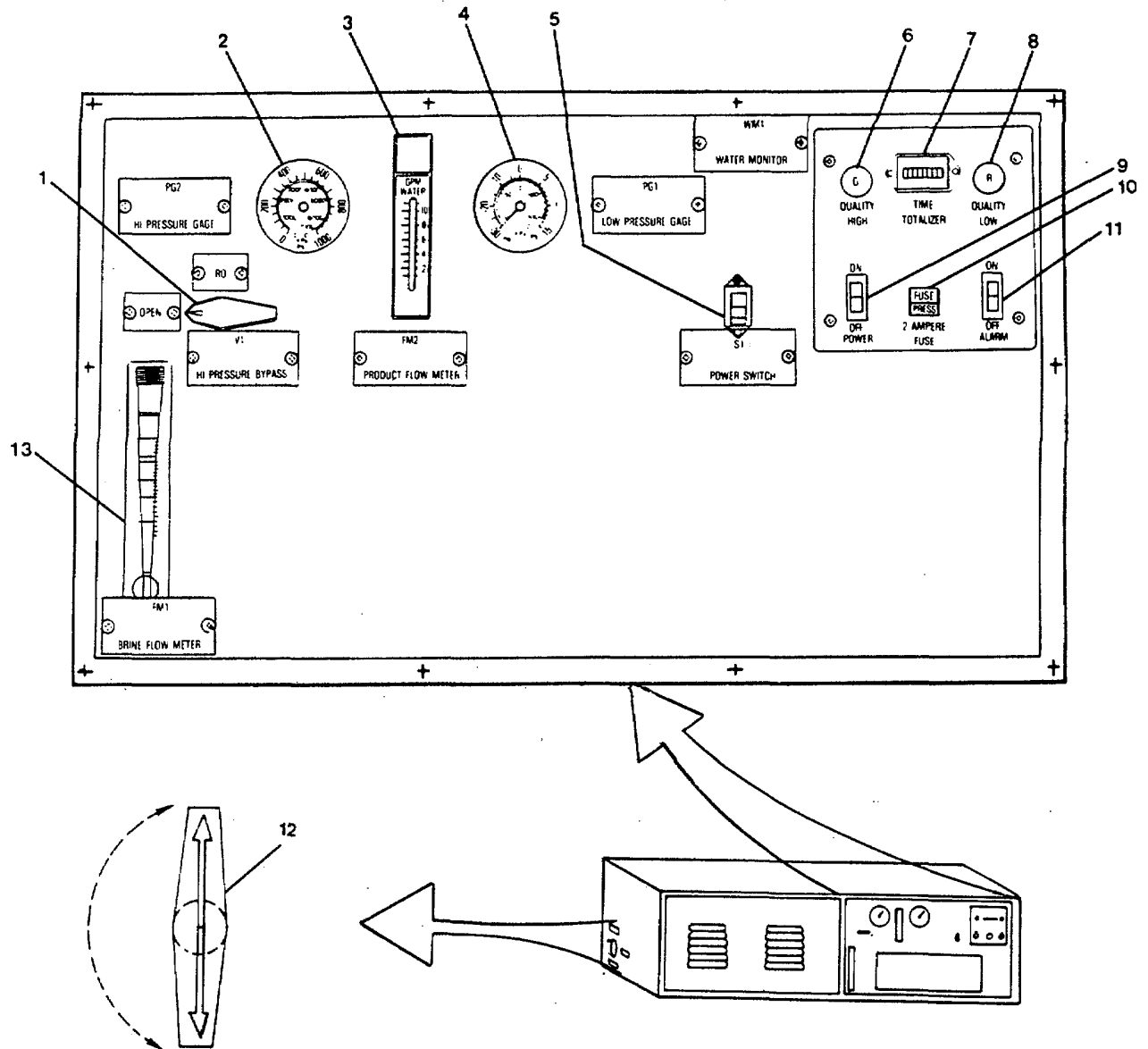

FIGURE 2-36. Reverse Osmosis Desalinator.

**Table 2-1. Description of Operator's Controls and Indicators - CONT**

Key	Control or Indicator	Function
Reverse Osmosis Desalinator (FIGURE 2-36)		
1	V1 HI PRESSURE BYPASS	Restricts downstream flow of reverse osmosis (RO) modules, causing the pump discharge pressure to rise to the factory set 800 psi.
2	PG2 HI PRESSURE GAGE	Indicates pressure in piping between the high pressure pump and the regulating valve.
3	FM2 PRODUCT FLOW METER	Indicates product water outflow from the RO modules.
4	PG1 LOW PRESSURE GAGE	Indicates pressure at the outlet of the micron filters.
5	S1 POWER SWITCH	Energizes the two pump motors and energizes switch contacts on the water monitor power switch.
6	QUALITY HIGH	Indicates the quality of water is acceptable and the water is being pumped into the ship's fresh water system (green).
7	TIME TOTALIZER	Indicates cumulative hours of system operation.
8	QUALITY LOW	Indicates the quality of water is low and the water is being dumped via the brine manifold (red).
9	ON OFF POWER	Controls electrical power to water quality monitor system.
10	2-AMPERE FUSE	Fuse holder. Fuse protects water quality monitor from amperage overload.
11	ON OFF ALARM	Controls electrical power to water quality monitor ALARM system.
12	Cleaning Valve	Controls system in OPERATE or CLEAN mode of operation.
13	FM1 BRINE FLOW METER	Indicates brine outflow before entering brine manifold.

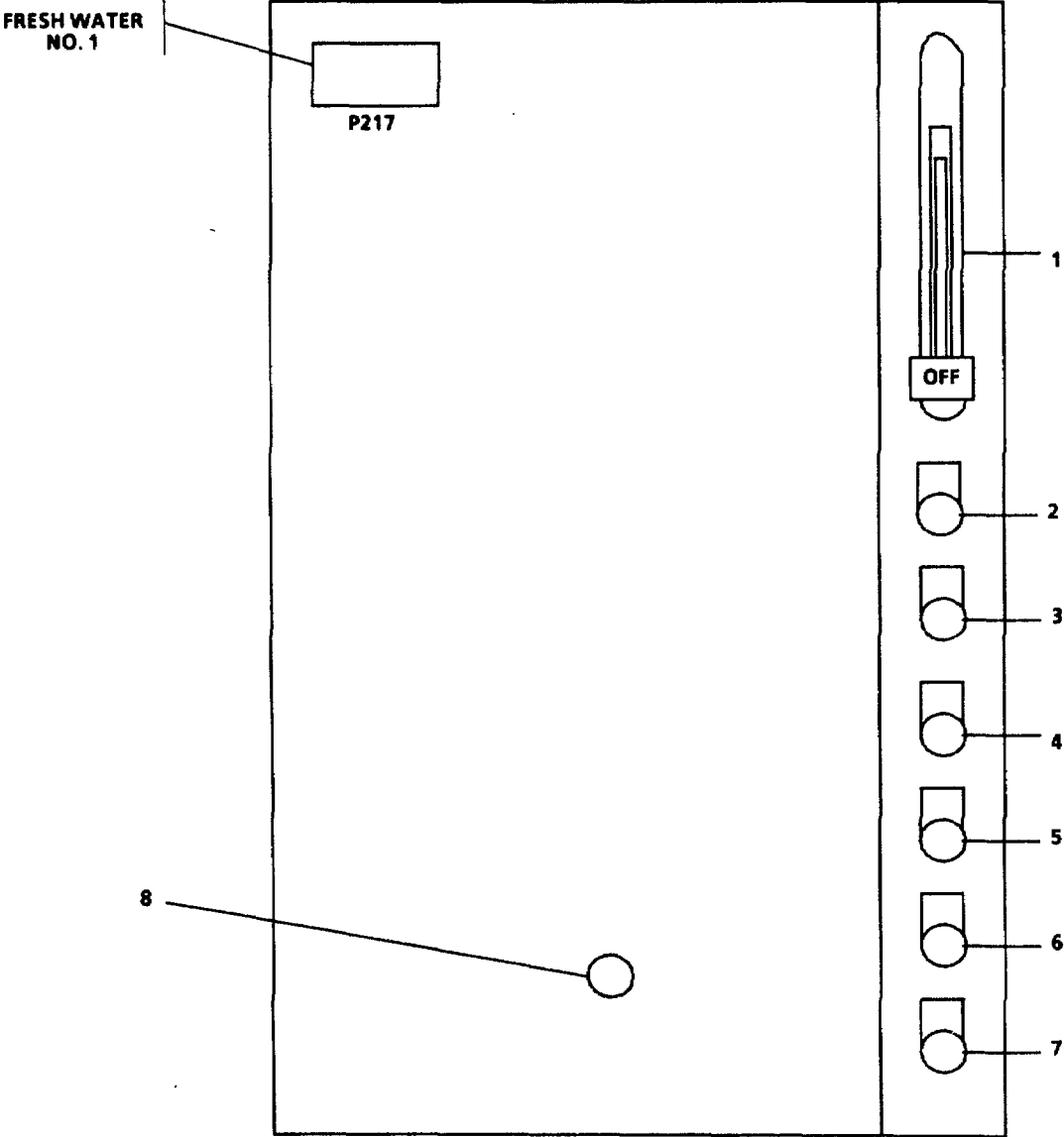

FIGURE 2-37. Fresh Water Motor Controller

**Table 2-1. Description of Operator's Controls and Indicators - CONT**

Key	Control or Indicator	Function
Fresh Water Motor Controller (FIGURE 2-37)		
1	ON-OFF	Provides ON-OFF control with 15-ampere circuit protection. Switch may be locked in OFF position.
2	HAND-OFF-AUTO	Switch HAND position provides continuous operation of the fresh water pump. OFF position stops the fresh water pump. AUTO position provides automatic operation of the fresh water pump.
3	START	Pushbutton starts fresh water maker.
4	STOP	Pushbutton stops fresh water maker.
5	MOTOR RUN	Indicates that fresh water maker is operating (green).
6	MOTOR STOP	Indicates that fresh water maker is stopped (white).
7	EMERGENCY RUN	Pushbutton activates fresh water maker for time pushbutton is pressed.
8	RESET	Resets fresh water make motor controller.

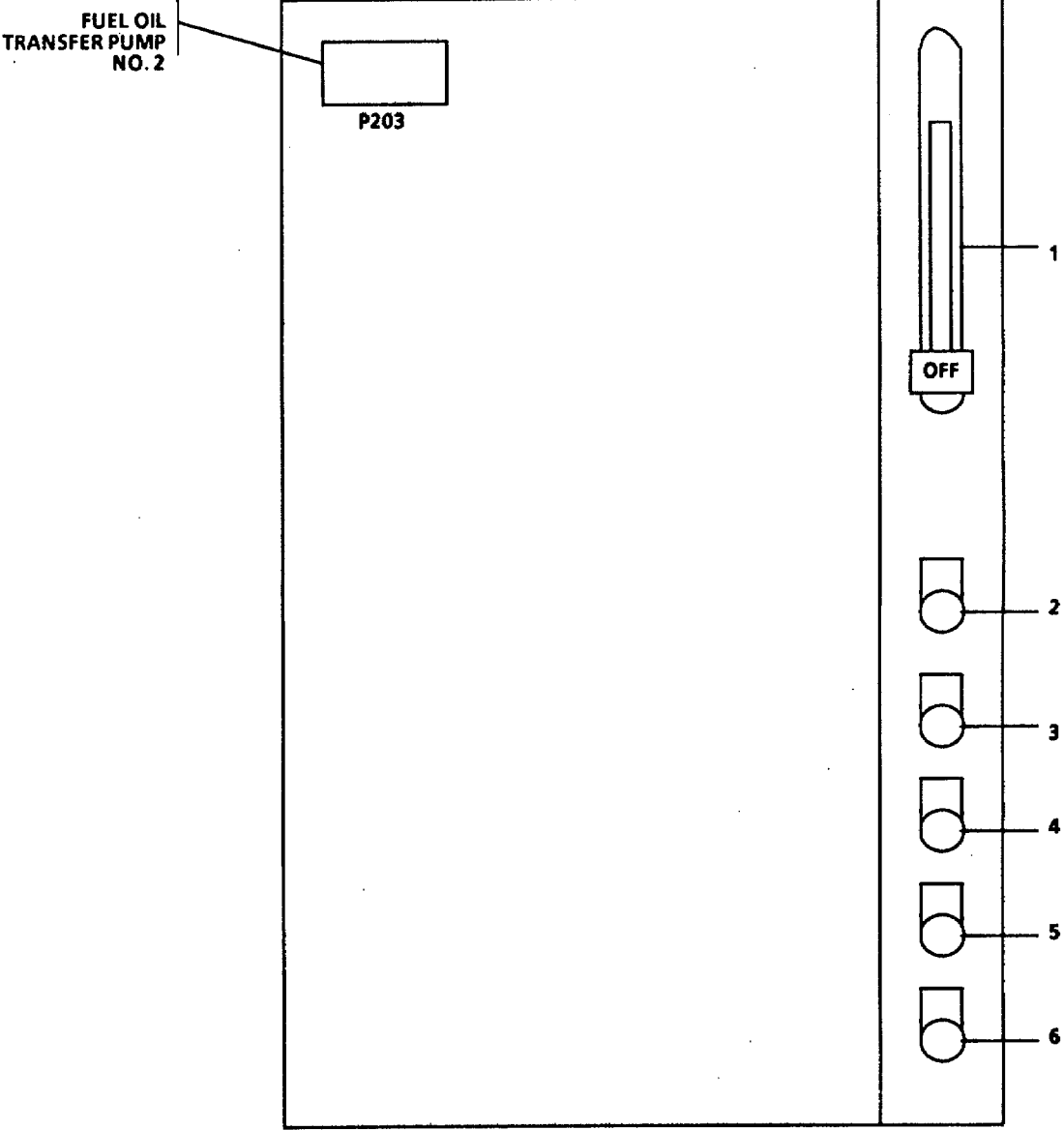

FIGURE 2-38. Fuel Oil Transfer Pump Motor Controller

**Table 2-1. Description of Operator's Controls and Indicators - CONT**

Key	Control or Indicator	Function
Fuel Oil Transfer Pump Motor Controller (FIGURE 2-38)		
1	ON-OFF	Provides ON-OFF control with 15-ampere circuit protection. Switch may be locked in OFF position.
2	START	Pushbutton starts fuel oil transfer pump No. 2.
3	STOP	Pushbutton stops fuel oil transfer pump No. 2.
4	MOTOR RUN	Indicates that fuel oil transfer pump No. 2 is operating (green).
5	MOTOR STOP	Indicates that fuel oil transfer pump No. 2 is stopped (white).
6	EMERGENCY RUN	Pushbutton activates fuel oil transfer for time pushbutton is depressed.

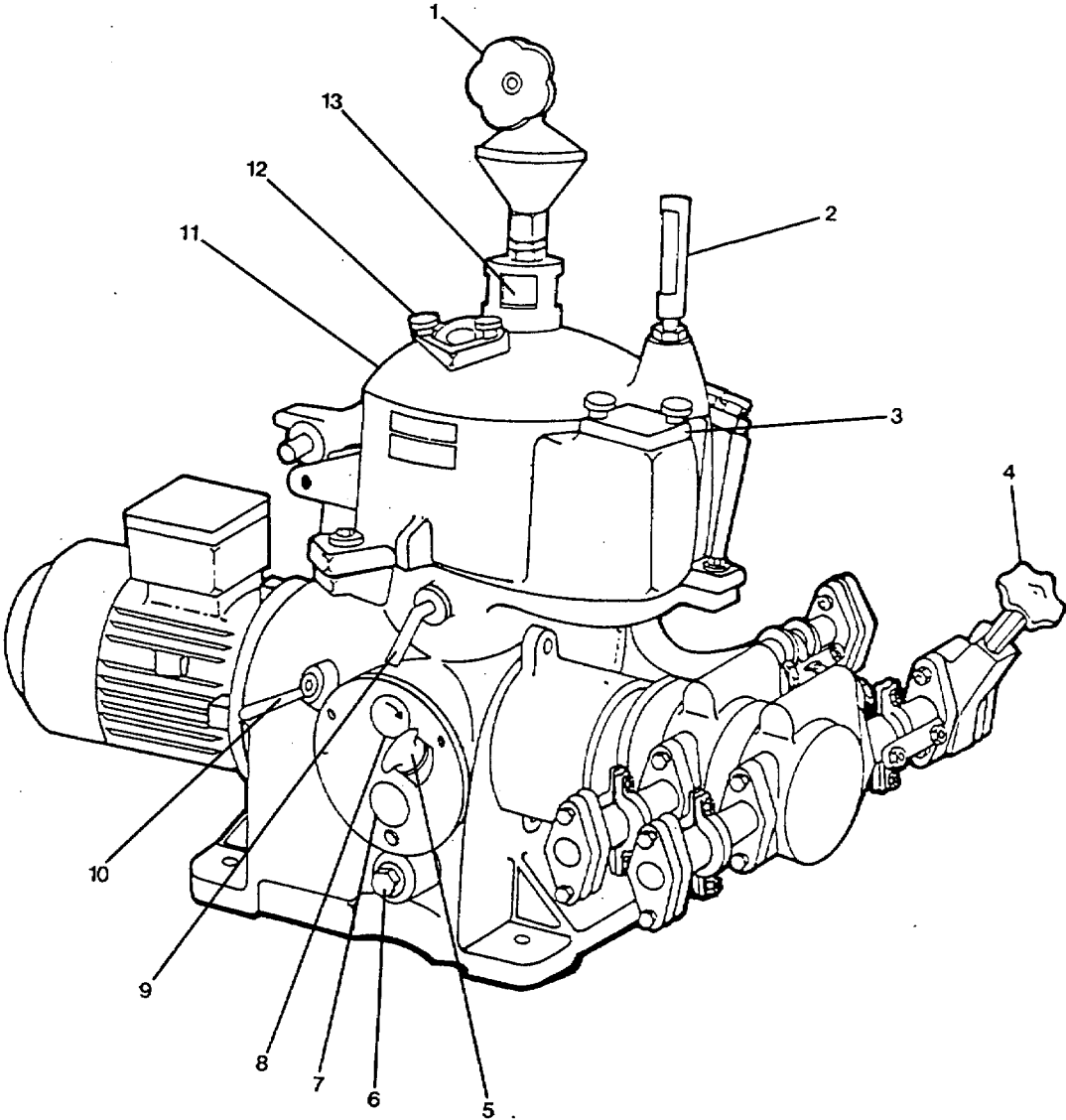

FIGURE 2-39. Lube Oil Purifier.



**Table 2-1. Description of Operator's Controls and Indicators - CONT**

Key	Control or Indicator	Function
Lube Oil Purifier (FIGURE 2-39)		
1	Needle Valve	Provides opening for filling bowl and throttle for amount of makeup water required for type of oil.
2	Thermometer	Indicates temperature of dirty oil.
3	Inspection Cover	Removed, allows observation of dirty water and clean oil discharges.
4	Valve	Adjusts dirty oil feed line capacity.
5	Oil Fill Screw	Open, allows gear oil replenishment.
6	Drain Cock	Drains oil from feed channel of hood.
7	Gear Oil Sight Glass	Indicates oil level in gear chamber; should be up to upper third of sight glass.
8	Revolution Indicator Disk	Indicates direction and speed of bowl rotation. Bowl must rotate in clockwise direction.
9	Lock Screw	Locks bowl in stationary position.
10	Brake Handle	Provides braking of motor driven gear train. Release brake by turning handle clockwise.
11	Hood	Provides access to bowl.
12	Inspection Cover	Removed, allows observation of dirty water oil discharges.
13	Dirty Oil Sight Glass	Indicates dirty-oil going to oil pre-heater.

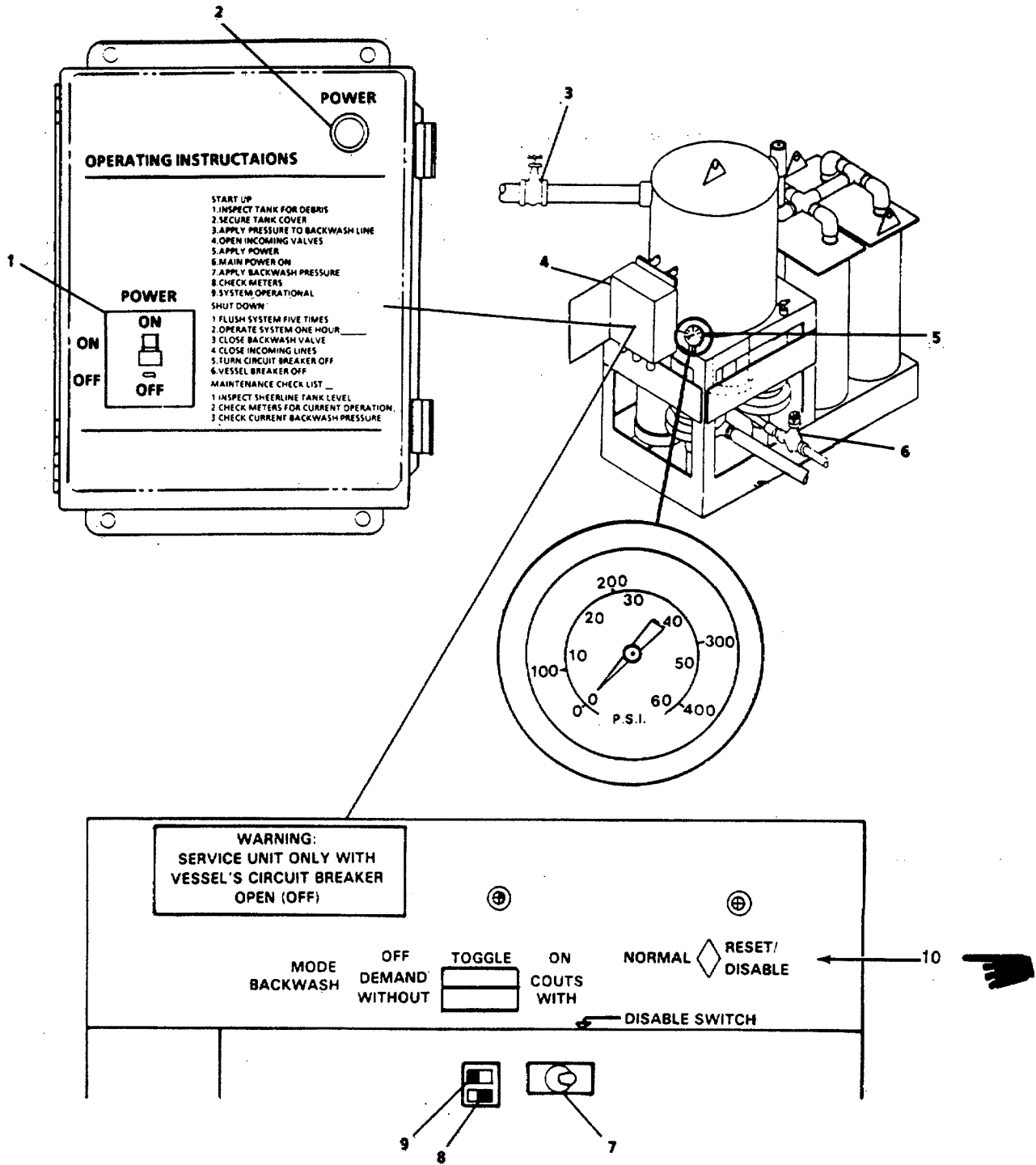

FIGURE 2-40. Marine Sanitation Device (Sheet 1 of 2)

**Table 2-1. Description of Operator's Controls and Indicators - CONT**

Key	Control or Indicator	Function
Marine, Sanitation Device (FIGURE 2-40)		
1	POWER ON-OFF	Turns ON the marine sanitation device.
2	POWER	Lights when power control switch is in ON position (green).
3	Sewage Inlet Valve	Provides opening for sewage flow to treatment tank.
4	Junction Box	Contains a solid state electronics package.
5	Pressure Gauge	Indicates backwash water system pressure.
6	Backwash Control Valve	Provides water pressure to backwash line.
7	Discharge Control Valve	
8	Switch #2	Controls operation of backwash solenoid.
9	Switch #1	Selects DEMAND or CONTINUOUS mode of operation.
10	NORMAL-RESET/ DISABLE	Selects NORMAL or CONTINUOUS mode of operation. In RESET/DISABLE position, the electronics and remote status indicators are bypassed.
11	MACERATOR	Indicates status of MACERATOR pump [flashing-operational, continuous-non-operational] (red).
12	POWER ON	Indicates main circuit breaker is closed (green).
13	HIGH LEVEL WARNING	Indicates treatment tank is filled to capacity (red).
14	Commode Warning Light	Indicates surge/holding tanks are filled to capacity (red).
15	BACKWASH	Indicates status of BACKWASH solenoid operated valve [flashing-operational, continuous-non-operational] (red).
16	DISCHARGE	Indicates status of DISCHARGE pump [flashing-operational, continuous-non-operational] (red).

Table 2-1. Description of Operator's Controls and Indicators - CONT

Key	Control or Indicator	Function
Marine Sanitation Device (FIGURE 2-40)		
17	SLUDGE RETURN	Indicates status of SLUDGE RETURN pump [flashing - operational, continuous - non-operational] (red).
18	FLOW	Indicates status of FLOW pump [flashing - operational, continuous - non-operational] (red).

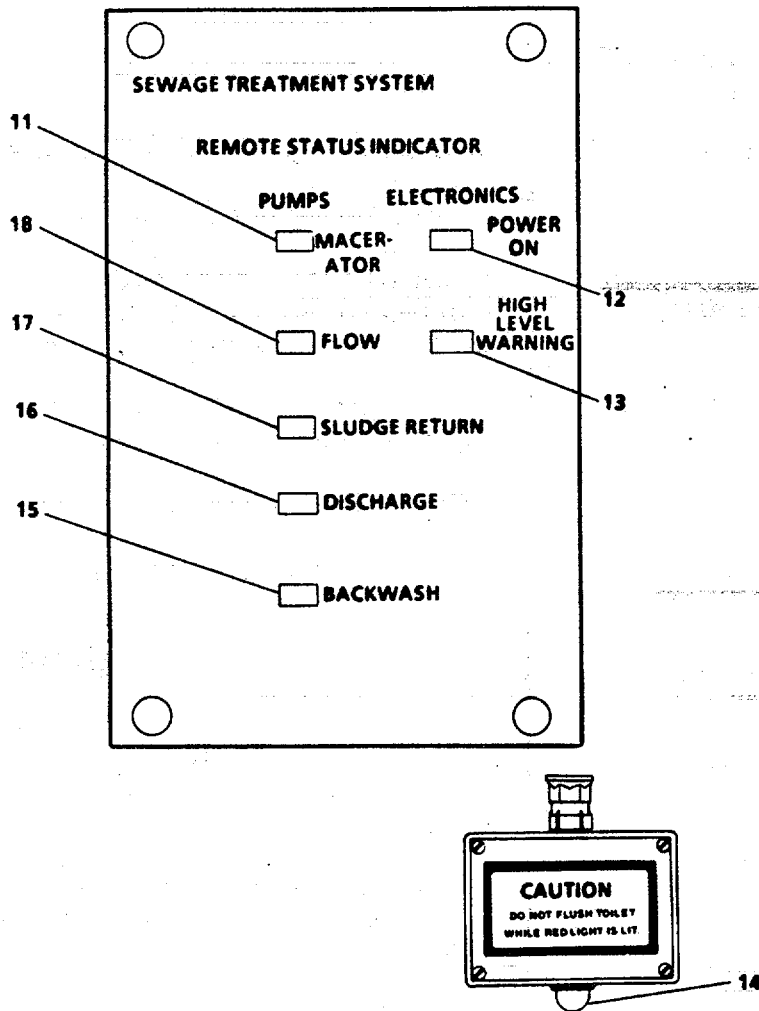

FIGURE 2-40. Marine Sanitation Device (Sheet 2 of 2).

**Table 2-1. Description of Operator's Controls and Indicators - CONT**

Key	Control or Indicator	Function
Steering Gear Motor Controller (FIGURE 2-41)		
1	ON-OFF	Provides ON-OFF control with 15 amperes circuit protection. May be locked in OFF position.
2	HAND-OFF-AUTO	Switch. HAND position provides continuous operation of steering gear motor. OFF position turns off steering gear motor. AUTO position provides automatic operation of steering gear motor.
3	MOTOR RUN	Indicates that steering gear motor is operating (green).
4	RESET	Resets steering gear motor controller.

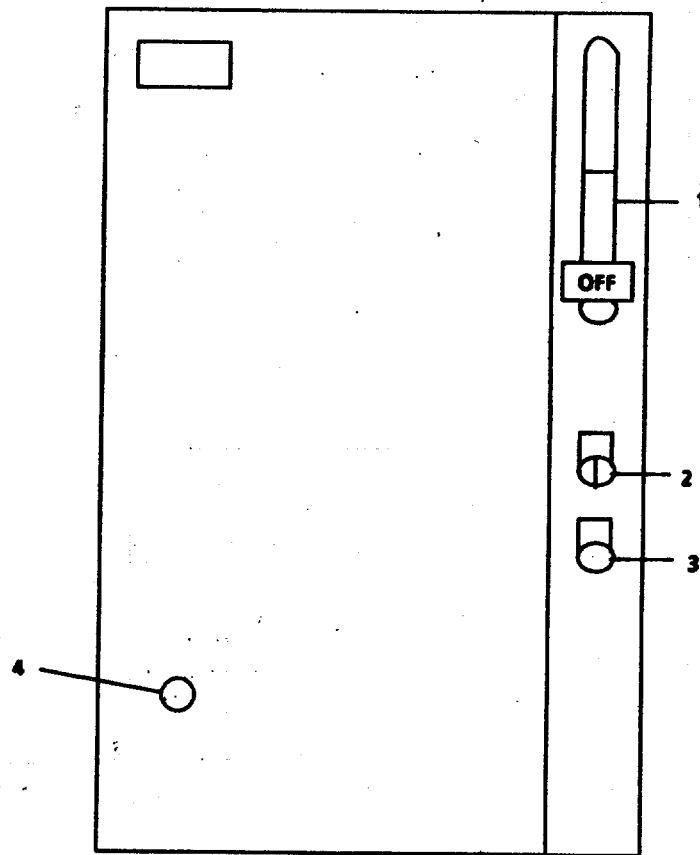
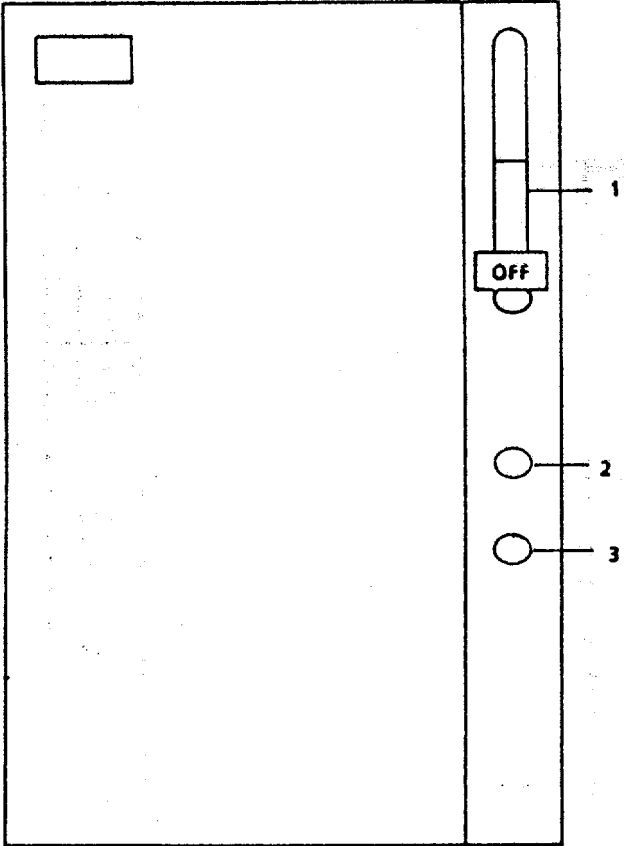

FIGURE 2-41. Steering Motor Controller.  
2-111

**Table 2-1. Description of Operator's Controls and Indicators - CONT**

Key	Control or Indicator	Function
	Steering Gear Motor Controller (FIGURE 2-41.1) Hulls 2008 and subsequent	
1	ON-OFF	Provides ON-OFF control with 15 amperes circuit protection. May be locked in OFF position.
2	MOTOR RUN	Indicates that steering gear motor is operating (green).
3	LOCAL-OFF-REMOTE	Selects Local or Remote Operation



*FIGURE 2-41.1. Steering Gear Motor Controller.*

Table 2-1. Description of Operator's Controls and Indicators - CONT

Key	Control or Indicator	Function
Steering Gear Room Local Control Unit (FIGURE 2-42)		
1	PORT STBD	Rudder angle indicator provides rudder position in relation to center line of vessel.
2	LOCAL REMOTE	Transfers steering control from pilothouse steering control panel to steering gear room local control unit.
3	PORT STBD	Operates rudders to port or starboard with control transfer switch in local position.

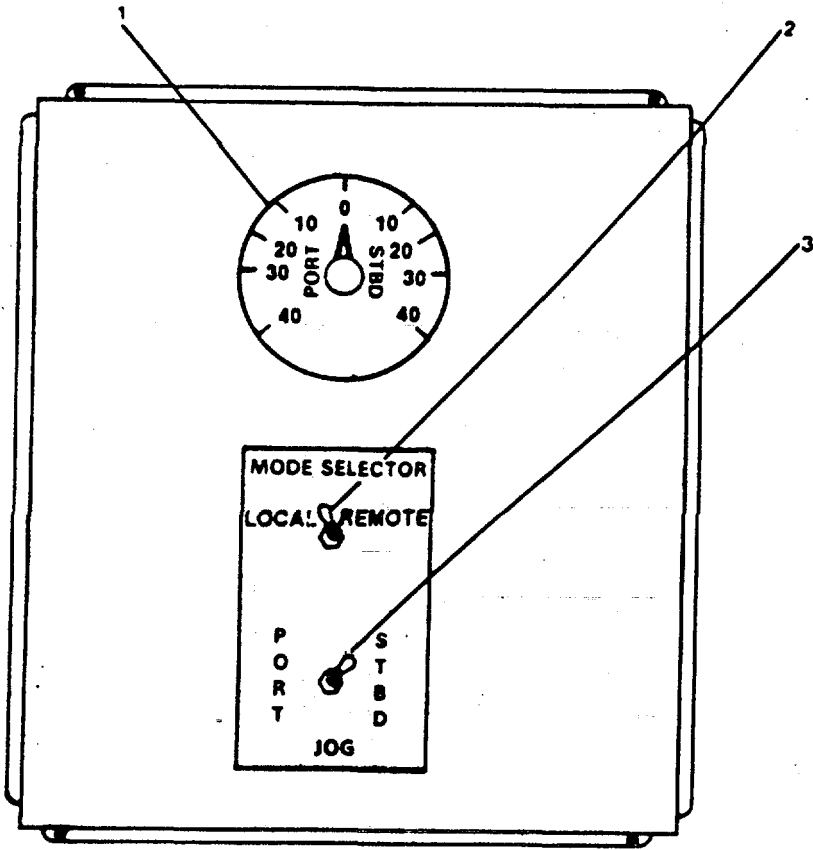

FIGURE 2-42. Steering Gear Room Local Control Unit.

**Table 2-1. Description of Operator's Controls and Indicators - CONT**

Key	Control or Indicator	Function
	Steering Gear Motor Controller (FIGURE 2-42.1) Hulls 2008 and subsequent	
1	MODE	Transfers steering control from pilothouse steering control panel to steering gear room local control unit.
2	Non-Follow-up	Operates rudders to port or starboard with control transfer switch in local position.
3	FUSES	Provides protection for electrical circuits.
4	RUDDER INDICATOR	Rudder angle indicator provides rudder position in relation to center line of vessel.

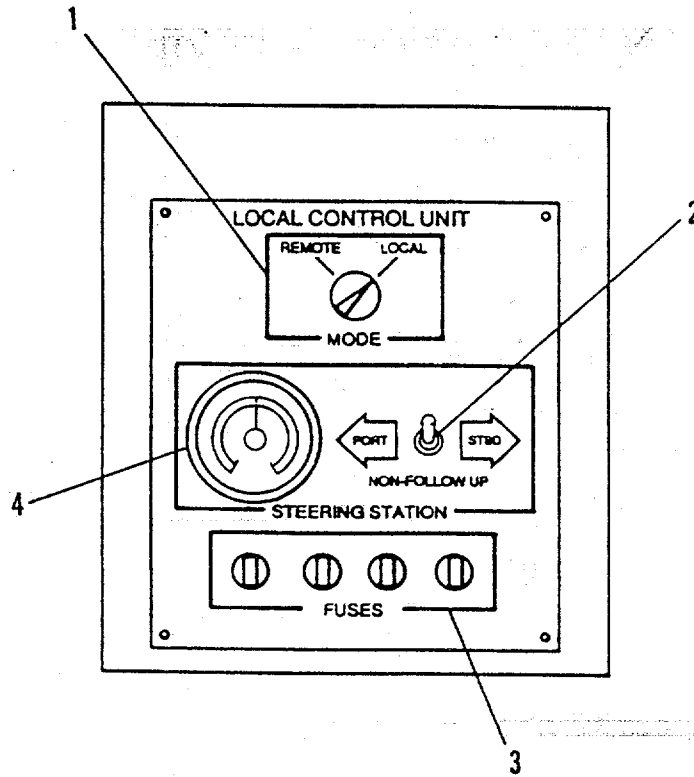

FIGURE 2-42.1. Steering Gear Room Local Control Unit.



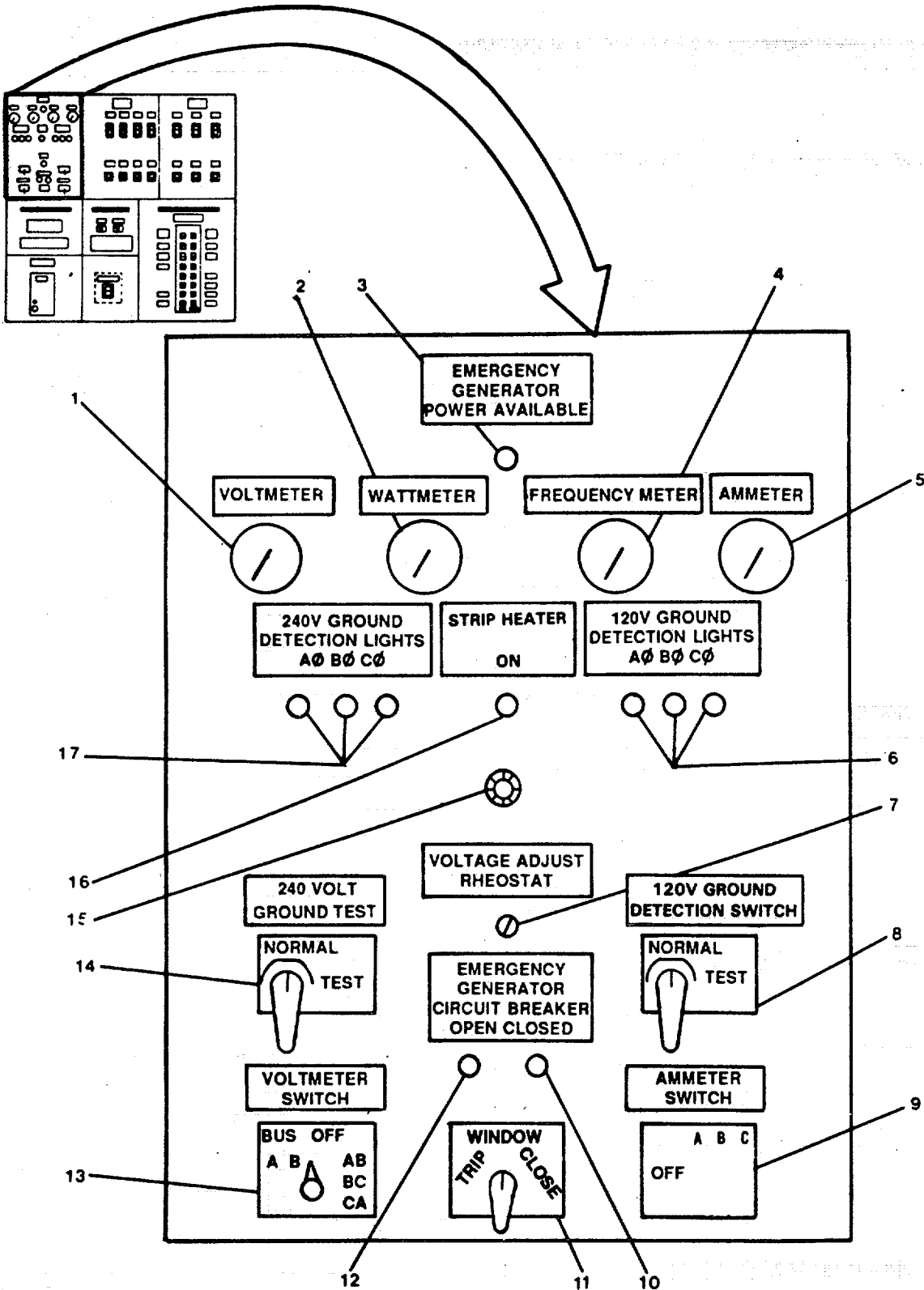

FIGURE 2-43. Emergency Switchboard (Sheet 1 of 4).

(2-114.1 blank)/2-114.2

**Table 2-1. Description of Operator's Controls and Indicators - CONT**

Key	Control or Indicator	Function
Emergency Switchboard (FIGURE 2-43)		
1	VOLTMETER	Indicates emergency generator voltage.
2	WATTMETER	Indicates emergency generator watt output.
3	EMERGENCY GENERATOR POWER AVAILABLE	Indicates emergency generator power is available (white).
4	FREQUENCY METER	Indicates emergency generator frequency.
5	AMMETER	Indicates emergency generator amperage.
6	120V GROUND DETECTION LIGHT	Indicates ground fault conditions on any one of these phases of the emergency generator (amber).
7	VOLTAGE ADJUST RHEOSTAT	Adjusts emergency generator voltage output.
8	120V GROUND DETECTION SWITCH	Provides test of 120V ground detection lights.
9	AMMETER SWITCH	Provides selection of phases A, B, or C for reading on AMMETER (5).
10	EMERGENCY GENERATOR CIRCUIT BREAKER CLOSED	Indicates circuit breaker is in closed position (red).
11	Circuit Breaker Control Switch	Selects TRIP or CLOSE position for emergency generator circuit breaker.
12	EMERGENCY GENERATOR CIRCUIT BREAKER OPEN	Indicates that circuit breaker is in OPEN position (green).
13	VOLTMETER SWITCH	Selects phases A-B, B-C, C-A, or BUS A-B for reading on VOLTMETER (1).
14	240 VOLT GROUND TEST	Provides test of 240V ground detection lights.

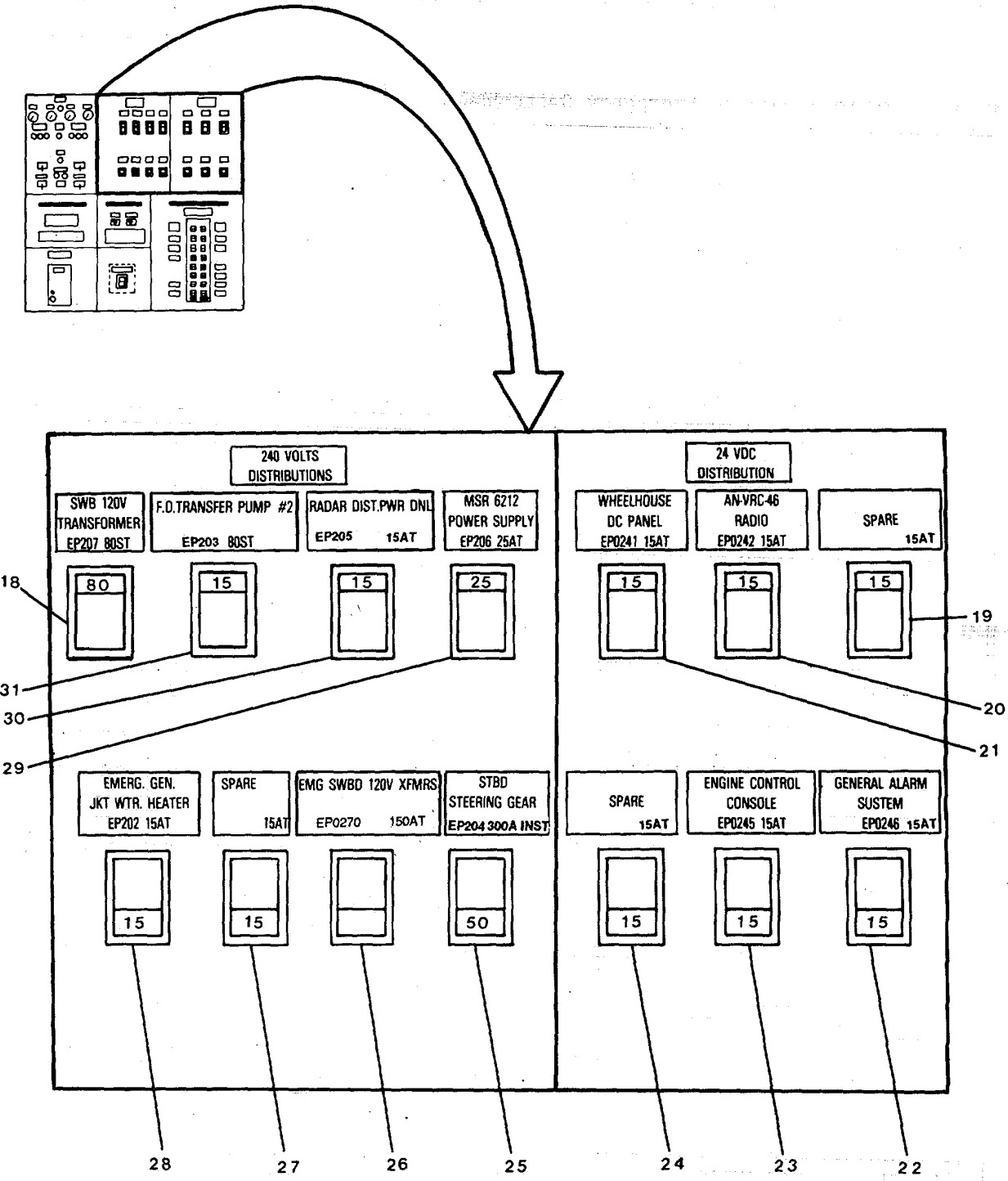

FIGURE 2-43. Emergency Switchboard (Sheet 2 of 4).

**Table 2-1. Description of Operator's Controls and Indicators - CONT**

Key	Control or Indicator	Function
Emergency Switchboard (FIGURE 2-43) - continued		
15	EMERGENCY GENERATOR SPEED CONTROL	Controls speed of Emergency Generator Engine.
16	STRIP HEATER ON	Indicates that engine STRIP HEATER is operating (red).
17	240V GROUND DETECTION LIGHTS	Indicates ground fault conditions on any one of three phases of the emergency generator (amber)
18	SWBD 120V TRANSFORMER P207	Provides 3-phase 240V with 80-ampere automatic trip circuit protection.
19	SPARE	Spare circuit breaker if additional distribution is required with 15 ampere automatic trip protection.
20	AN-VRC-46 overload RADIO EP0242	Provides AN/VRC-46 with 24 Vdc amperage protection.
21	WHEELHOUSE DC PANEL EP0241	Provides Power Panel EP0241 with amperage overload protection.
22	GENERAL ALARM SYSTEM EP0246	Provides general alarm system with 24 Vdc amperage overload protection.
23	ENGINE CONTROL CONSOLE EP0245	Provides engine control console with 24 Vdc amperage overload protection.
24	SPARE	Spare circuit breaker if additional distribution is required with 15 ampere automatic trip protection.
25	PORT STEERING GEAR EP2042	Provides port steering gear with amperage overload protection.
26	ENG SWBD 120V XFMR EP0207	Provides power panel EP0207 with amperage overload protection.

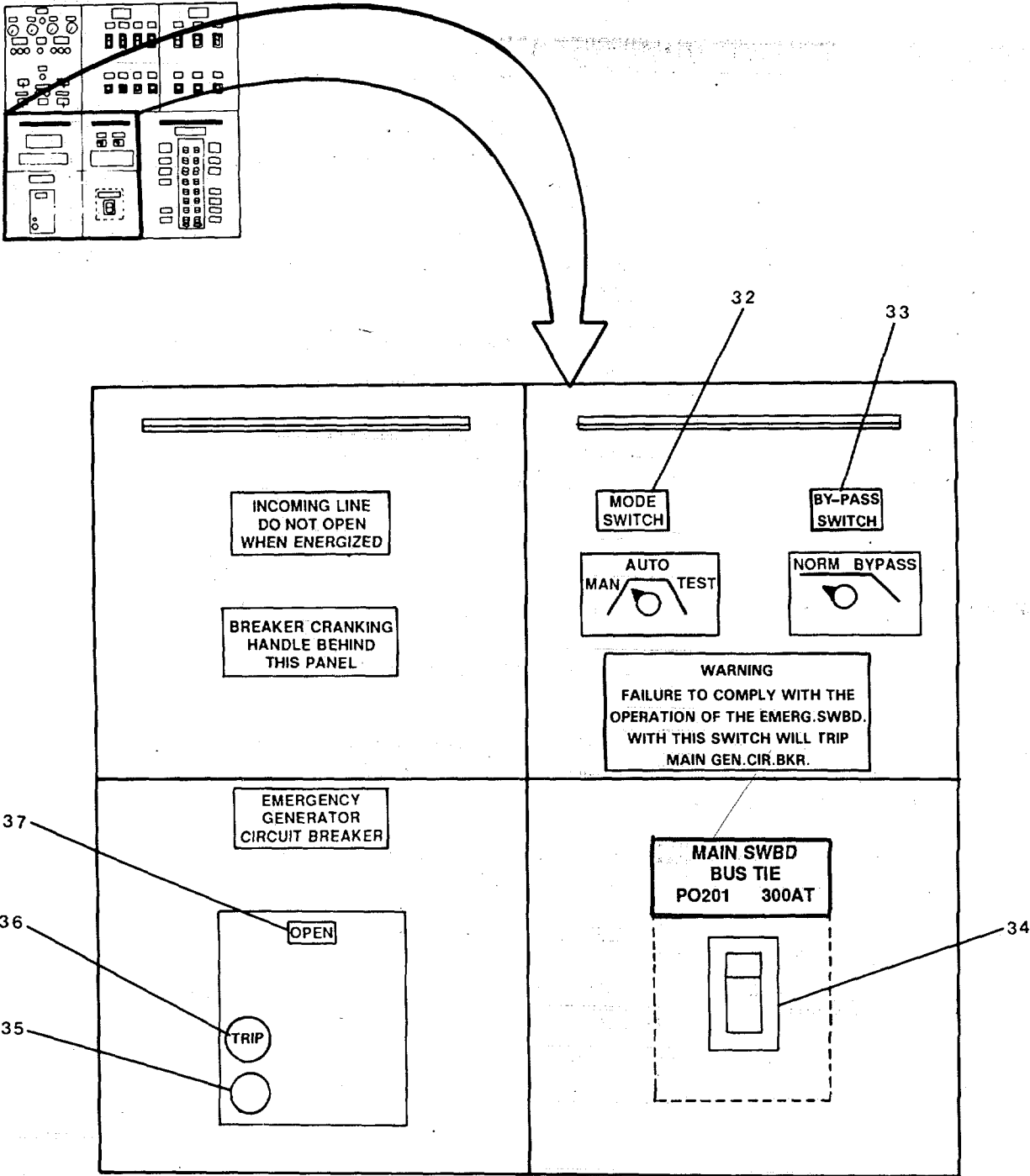

FIGURE 2-43. Emergency Switchboard (Sheet 3 of 4).

**Table 2-1. Description of Operator's Controls and Indicators - CONT**

Key	Control or Indicator	Function
Emergency Switchboard (FIGURE 2-43) - continued		
27	SPARE 15AT	Spare circuit breaker if additional distribution is required with 15 ampere automatic trip protection.
28	EMER. GEN. JKT. WATER HEATER EP202 15AT	Provides Emergency Generator Jacket Water Heater with amperage overload protection.
29	MSR 6212 POWER SUPPLY EP206 25AT	Provides MSR 6212 Power Supply with amperage overload protection.
30	RADAR DIST PWR PNL EP205 15AT	Provides Power Panel EP205 with amperage overload protection.
31	FO TRANSFER PUMP 1 EP203 15AT	Provides Fuel Oil Transfer Pump No. 1 with amperage overload protection.
32	MODE SWITCH	Selects MAN, AUTO, or TEST modes of operation.
33	BY-PASS	Allows feeding of power to Main Switchboard. SWITCH
34	MAIN SWBD BUS TIE P201 300AT	Provides 3 phase 240 volts with 300-ampere automatic trip circuit protection.
35	RACKING SCREW	Door slides to allow breaker cranking end to engage racking screw.
36	TRIP	Pushbutton to open circuit breaker.
37	OPEN            CLOSED	Indicates circuit breaker open (green). Indicates circuit breaker closed (red).

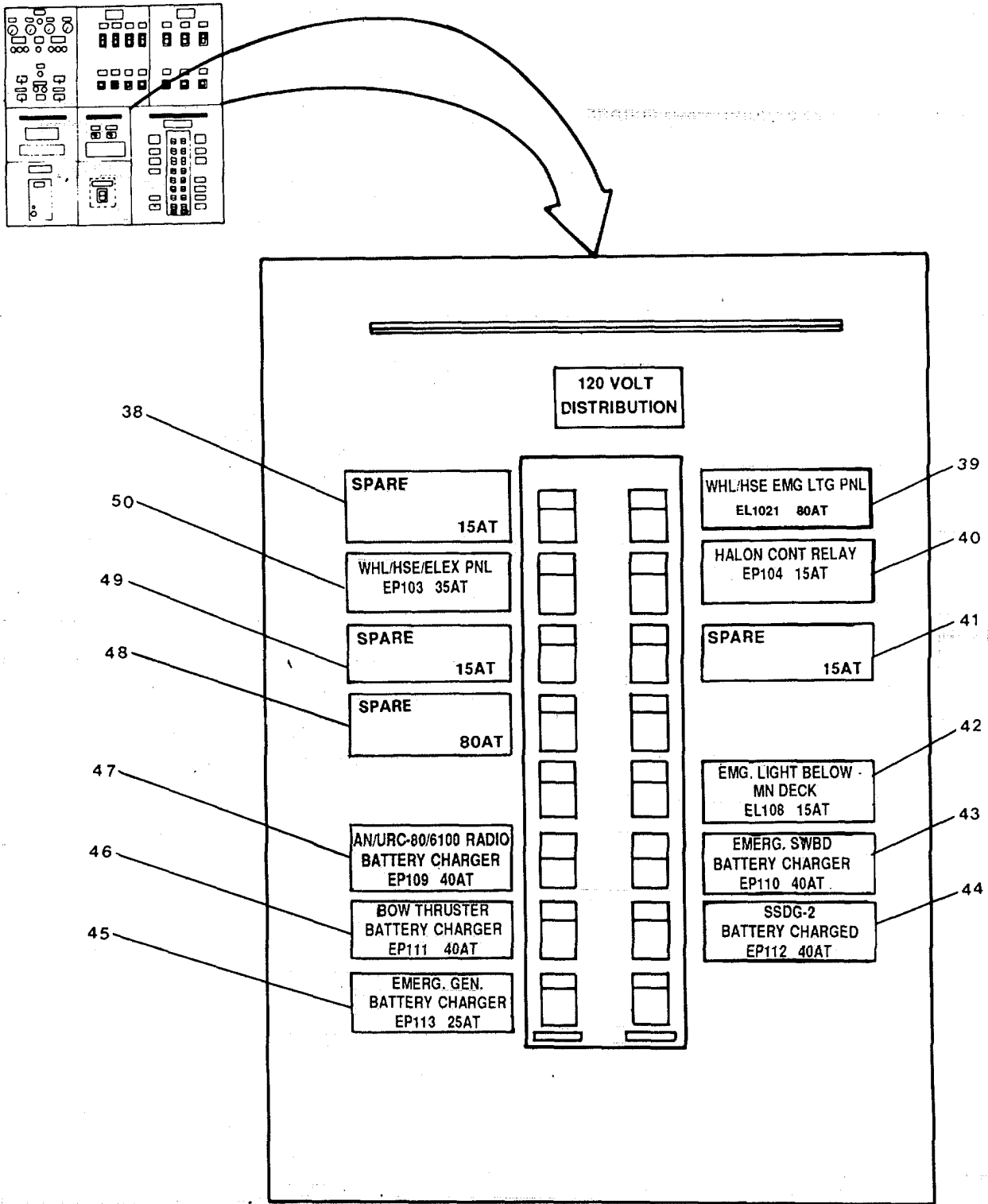

FIGURE 2-43. Emergency Switchboard (Sheet 4 of 4).

Table 2-1. Description of Operator’s Controls and Indicators – CONT

Key	Control or Indicator	Function
Emergency Switchboard (FIGURE 2-43) – Continued		
38	SPARE 80AT	Spare circuit breaker if additional distribution is required with 80-ampere circuit problem.
39	WHL/HSE ENG LTG PNL EP102 (1) 60AT	Protects Power Panel EP102 (1) with amperage overload protection.
<b>NOTE</b>		
<b>Not applicable to vessels with FM-200 Fire Suppressant System installed.</b>		
40	HALON CONT RELAY EP105 15AT	Provides Halon Cont Relay with amperage overload protection.
41	SPARE 15AT	Spare circuit breaker if additional distribution is required with 15-ampere circuit protection.
42	EM LTG BELOW MN DECK EP110 15AT	Provides power panel EP110 with amperage overload protection.
43	EMERG. SWBD BATTERY CHARGER EP112 40AT	Provides emergency switchboard battery charger with amperage overload protection.
44	SSDG 2 BATTERY CHARGER EP112 40AT	Provides the SSDG No. 2 with automatic trip circuit protection.
45	EMER GEN BATTERY CHARGER EP113 25AT	Provides the emergency generator battery charger with automatic trip circuit protection.
46	BOW THRUSTER BATTERY CHARGER EP109 40AT	Provides the bowthruster battery charger with automatic trip circuit protection.
47	AN/URC-80/6100 RADIO BATTERY CHARGER EP109 40AT	Provides power panel EP109 with amperage overload protection.
48	SPARE 80AT	Spare circuit breaker if additional distribution is required with 80-ampere circuit protection.
49	SPARE 15AT	Spare circuit breaker if additional distribution is required with 15-ampere circuit protection.
50	WHL/HSE/ELEX PNL EP103 35AT	Provides power panel EP103 with amperage overload protection.



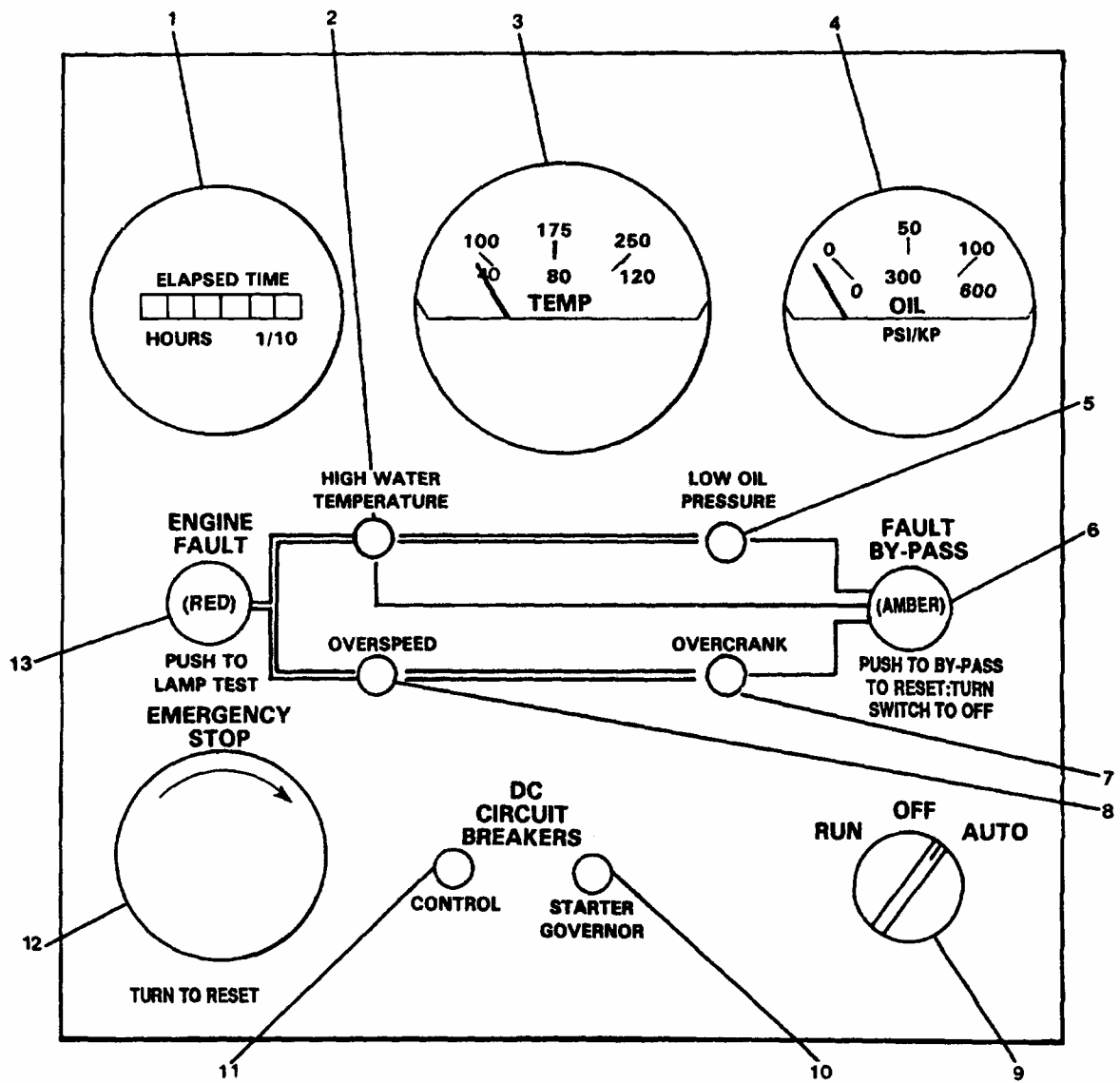

FIGURE 2-44. Emergency Generator Diesel Engine Control Panel.

**Table 2-1. Description of Operator's Controls and Indicators - CONT**

Key	Control or Indicator	Function
Emergency Generator Diesel Engine Control Panel (FIGURE 2-44)		
1	ELAPSED TIME HOURS	Records cumulative time of engine operation. 1/10
2	HIGH WATER TEMPERATURE	Circuit breaker opens when engine shuts down for high water temperature.
3	TEMP	Indicates engine water temperature.
4	OIL PSI/KP	Indicates oil engine pressure.
5	LOW OIL PRESSURE	Circuit breaker opens when engine shuts down for low oil pressure.
6	FAULT BY-PASS	Push to by-pass. To reset, turn RUN-OFF-AUTO switch to OFF (amber).
7	OVERCRANK OVERCRANK condition.	Circuit breaker opens when engine shuts down for
8	OVERSPEED OVERSPEED	Circuit breaker opens when engine shuts down for condition.
9	RUN-OFF-AUTO	Set to RUN for manual operation; AUTO for normal operation.
10	STARTER GOVERNOR	Circuit breaker opens for malfunction in starter or governor wiring systems.
11	CONTROL	Circuit breaker opens for short in control panel wiring.
12	EMERGENCY STOP	Push to stop engine. Turn clockwise to reset.
13	ENGINE FAULT	Illuminates when any circuit breaker opens (red).

Table 2-1. Description of Operator's Controls and Indicators - CONT

Key	Control or Indicator	Function
15 Ton A/C Controller (FIGURE 2-45)		
1	RESET-OFF-ON	Controls power to motor controller.
2	FAN OFF COMPRESSOR	Controls operating mode of air conditioning unit.

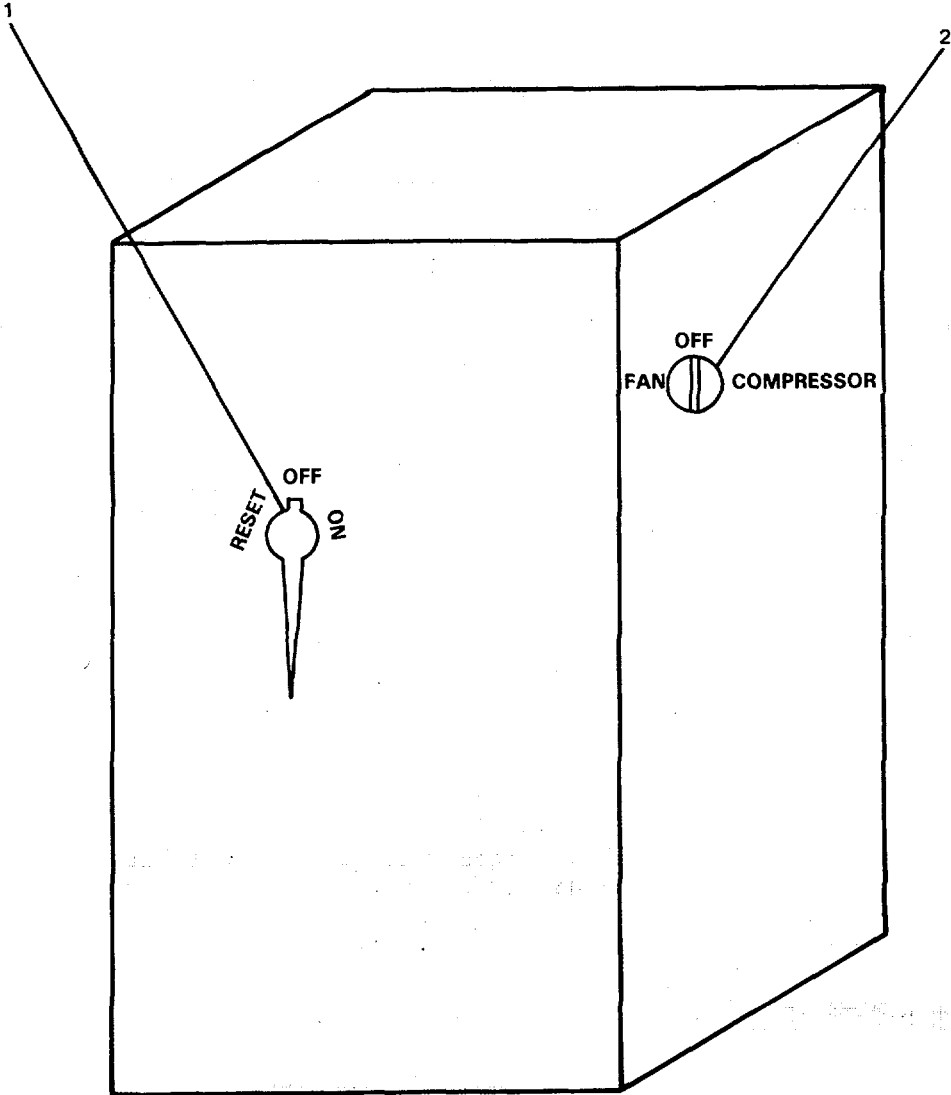

FIGURE 2-45. 15 Ton A/C Controller.

**Table 2-1. Description of Operator's Controls and Indicators - CONT**

Key	Control or Indicator	Function
Bowthruster Waterjet (FIGURE 2-46)		
1	Manual Control Valve Level	Provides manual waterjet control in bowthruster room.
2	Throttle	Controls speed of bowthruster engine.
3	Sight Gauge	Provides oil quantity readings.
4	Filler Cap	Removal of filler cap allows refill of hydraulic oil storage tank.
5	Sight Gauge	Provides hydraulic oil quantity and temperature readings.

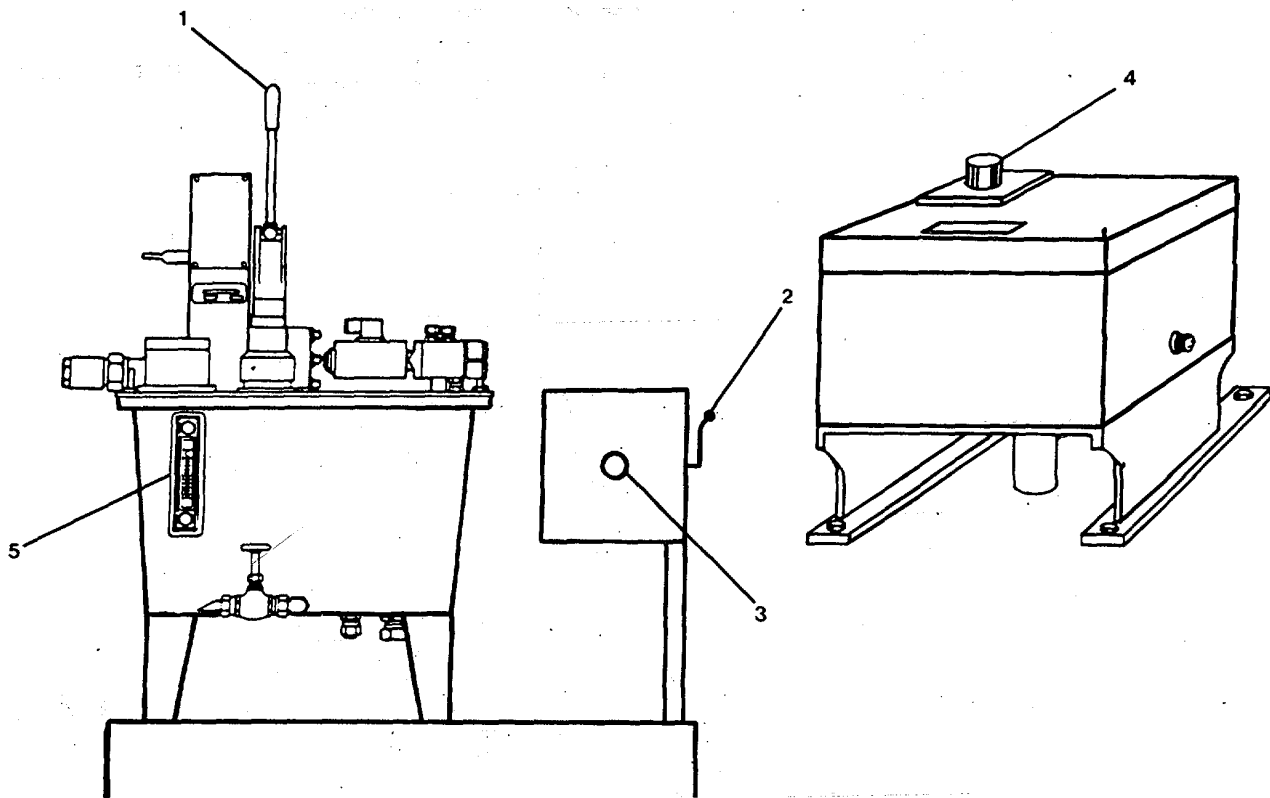
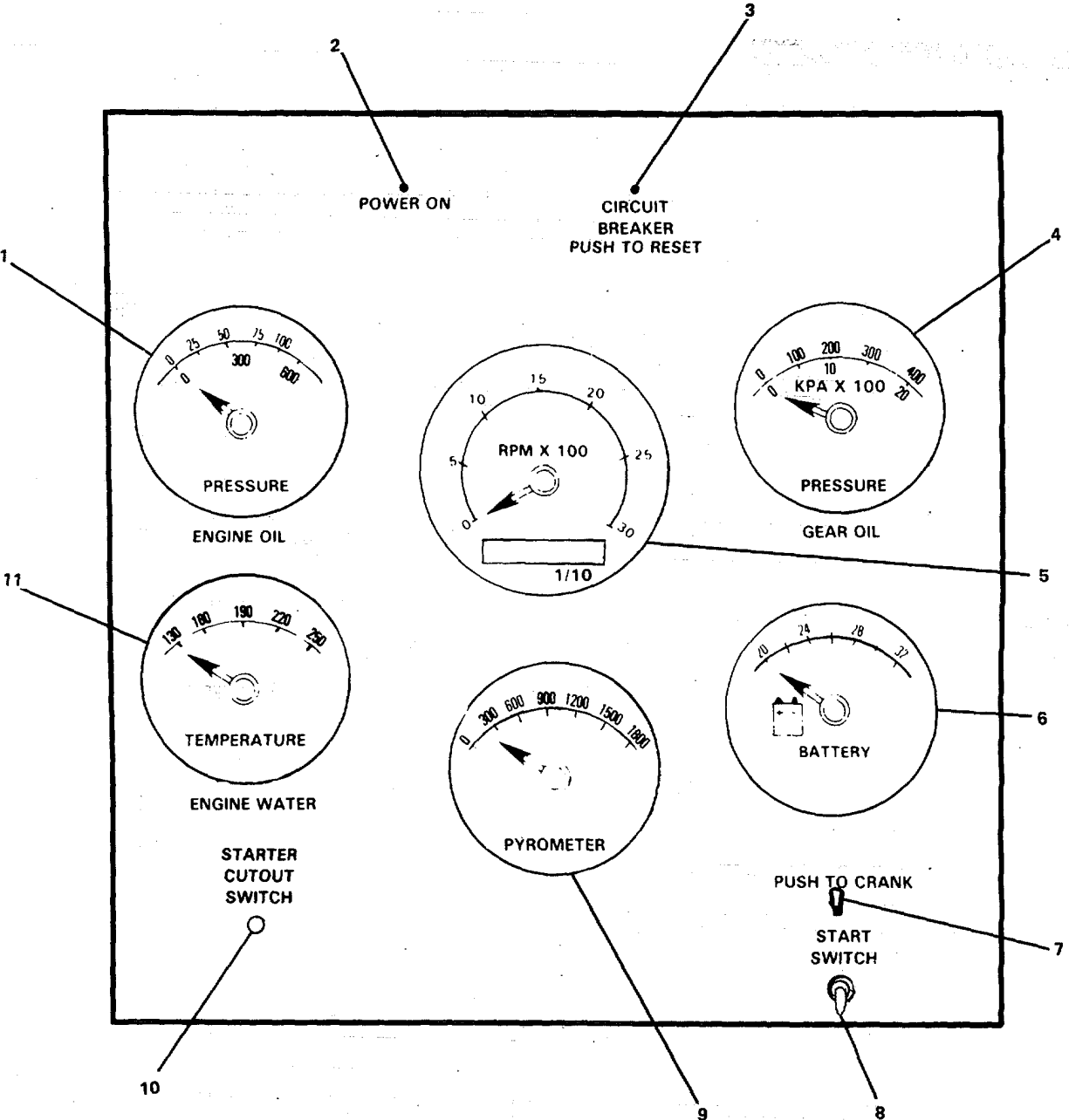

FIGURE 2-46. Bowthruster Waterjet.



- LEGEND**
- 1. START SWITCH
  - 2. STARTER CUTOUT SWITCH

FIGURE 2-47. Bowthruster Engine Control Panel.

**Table 2-1. Description of Operator's Controls and Indicators - CONT**

Key	Control or Indicator	Function
Bowthruuster Engine Control Panel (FIGURE 2-47)		
1	ENGINE OIL	Indicates engine oil pressure.
2	POWER ON	Indicates control panel power is on.
3	CIRCUIT BREAKER PUSH TO RESET	Provides control panel circuit protection.
4	GEAR OIL	Indicates gear oil pressure.
5	RPM X 100	Indicates bowthruuster engine rpm.
6	BATTERY	Indicates battery charge condition.
7	PUSH TO CRANK	Depress pushbutton to start engine.
8	Toggle Switch	In UP position, engine can be started, in DOWN position cannot be started.
9	PYROMETER	Indicates exhaust gas temperature.
10	STARTER CUTOUT SWITCH EOS	In UP position, engine started local or from pilothouse. In DOWN position, pilothouse and control is cut out.
11	ENGINE WATER	Indicates engine water temperature.

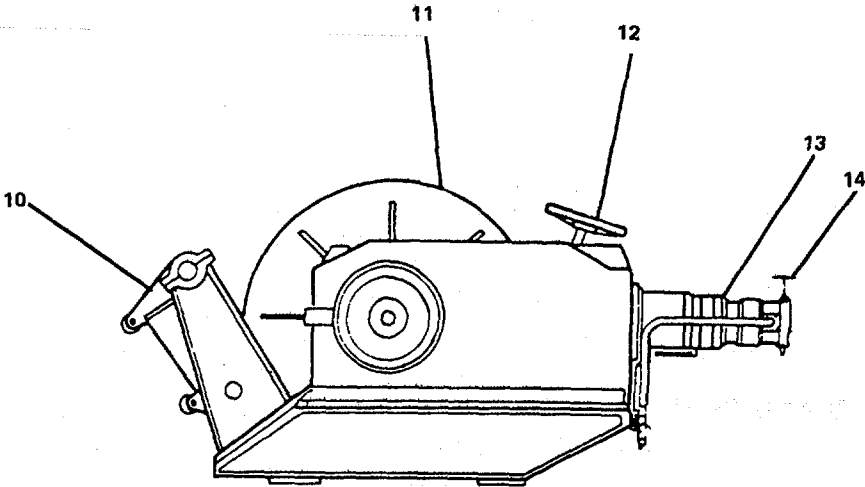
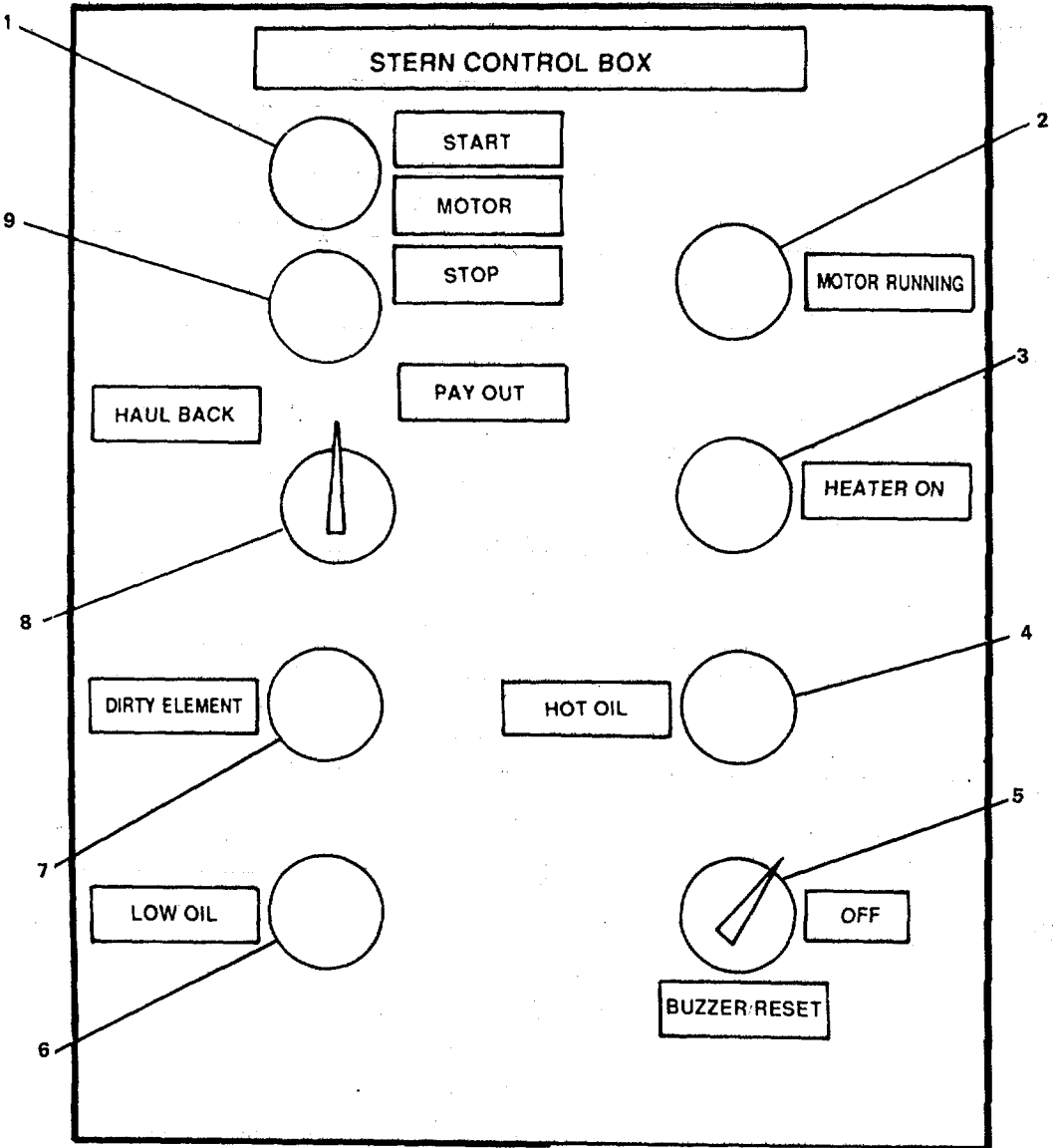

FIGURE 2-48. Stern Anchor Winch Control (Sheet 1 of 3).

**Table 2-1. Description of Operator's Controls and Indicators - CONT**

Key	Control or Indicator	Function
Stern Anchor and Winch Controls (FIGURE 2-48)		
1	START	Pushbutton starts stern anchor winch hydraulic pump motor (green).
2	MOTOR RUNNING	Indicates hydraulic pump motor is operating (green).
3	HEATER ON	Not used.
4	HOT OIL	Indicates hydraulic oil temperature is above normal (red).
5	BUZZER RESET	Resets alarm signal.
6	LOW OIL	Indicates hydraulic oil level is low and should be replenished (red).
7	DIRTY ELEMENT	Indicates hydraulic oil filter element should be cleaned or replaced (red).
8	HAUL OUT                      PAY OUT	Moving switch to HAUL BACK position rotates main spool counterclockwise and hauls in anchor. Moving switch to PAY OUT position rotates main spool clockwise and pays out anchor.
9	STOP	Pushbutton stops stern anchor winch hydraulic pump motor (red)
10	Level Wind Carriage	Level winds wire rope onto main spool.
11	Main Spool	Stores stern anchor wire rope.
12	Brake Handwheel	Engages mechanical brakes on stern anchor winch drum.
13	Hydraulic Failsafe Brake	Locks brakes stopping main spool rotation when hydraulic pressure is lost.
14	Hydraulic Motor Assy Flow (Speed Control Valve)	Controls speed of stern anchor winch.



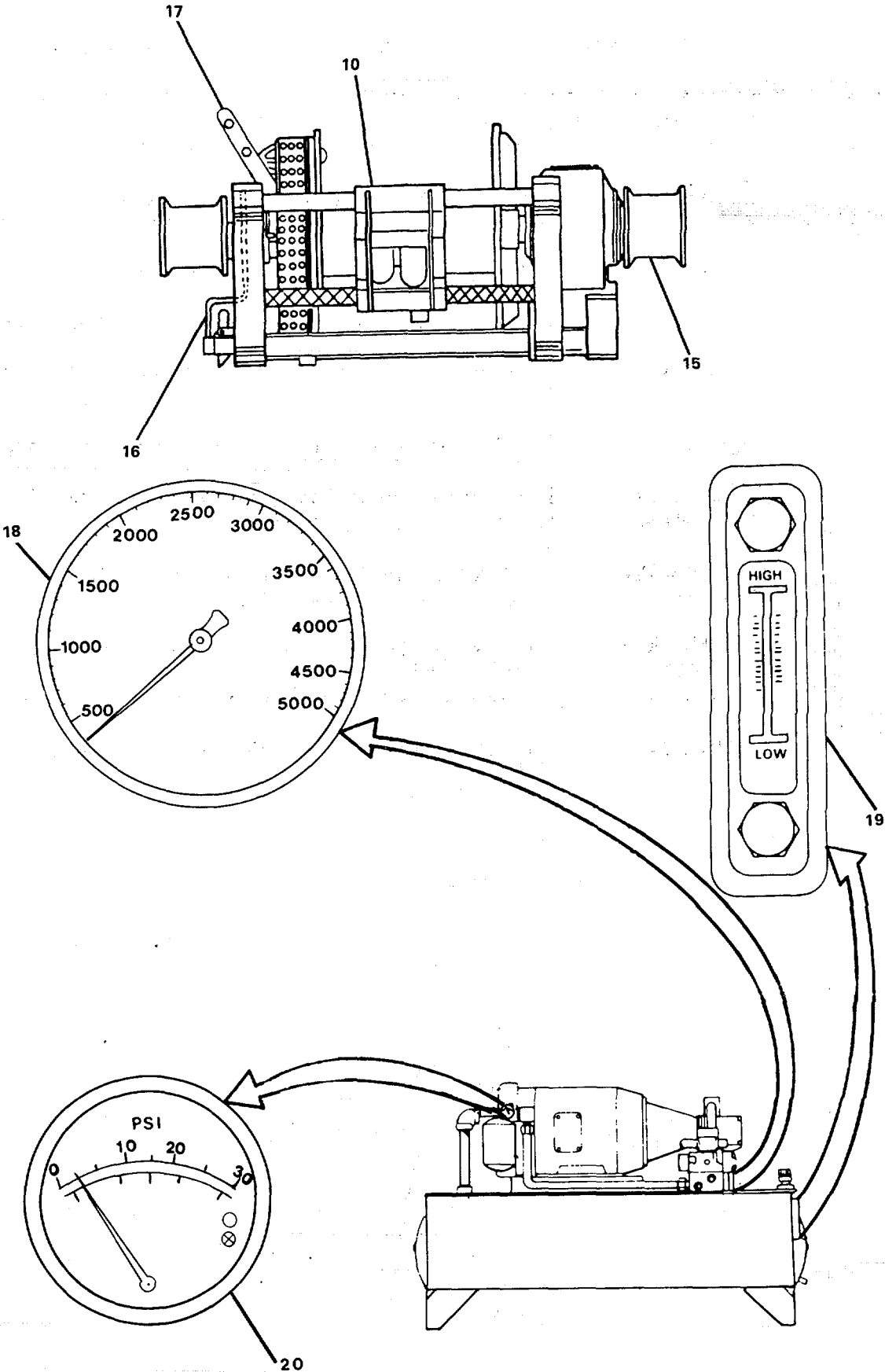

FIGURE 2-48. Stern Anchor Winch Control (Sheet 2 of 3).  
2-130

**Table 2-1. Description of Operator's Controls and Indicators - CONT**

Key	Control or Indicator	Function
Stern Anchor and Winch Controls (FIGURE 2-48) - Continued		
15	Cat Head	Hauls in/pays out auxiliary wire rope or line.
16	Dog Lever	Engages or disengages dog lug on spool flange.
17	Clutch Lever	Manually operated locking mechanism for IN or OUT operation.
18	Pressure Indicator	Indicates stern anchor winch hydraulic pressure.
19	Fluid Level Sight Glass	Indicates fluid level and temperature of stern anchor hydraulic fluid.
20	Filter Condition Indicator	Indicates when stern anchor winch hydraulic filter needs to be changed.
21	Anchor Shackle	Connects anchor to detachable link.
22	Pad Eyes	Attachments for anchor holdback wire rope.
23	Turnbuckle	Attaches to pad eyes and supports anchor.

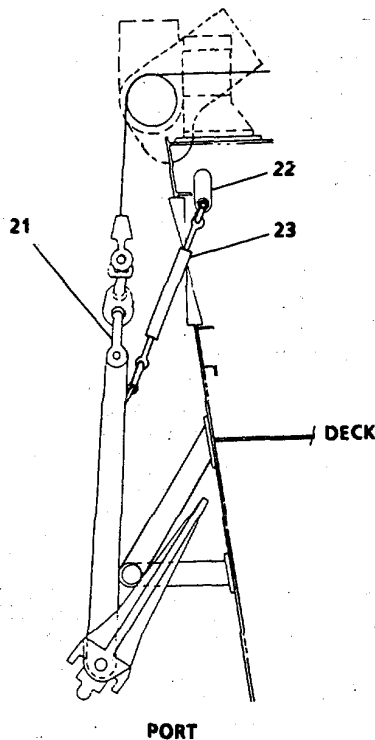

FIGURE 2-48. Stern Anchor Winch Controls (Sheet 3 of 3).

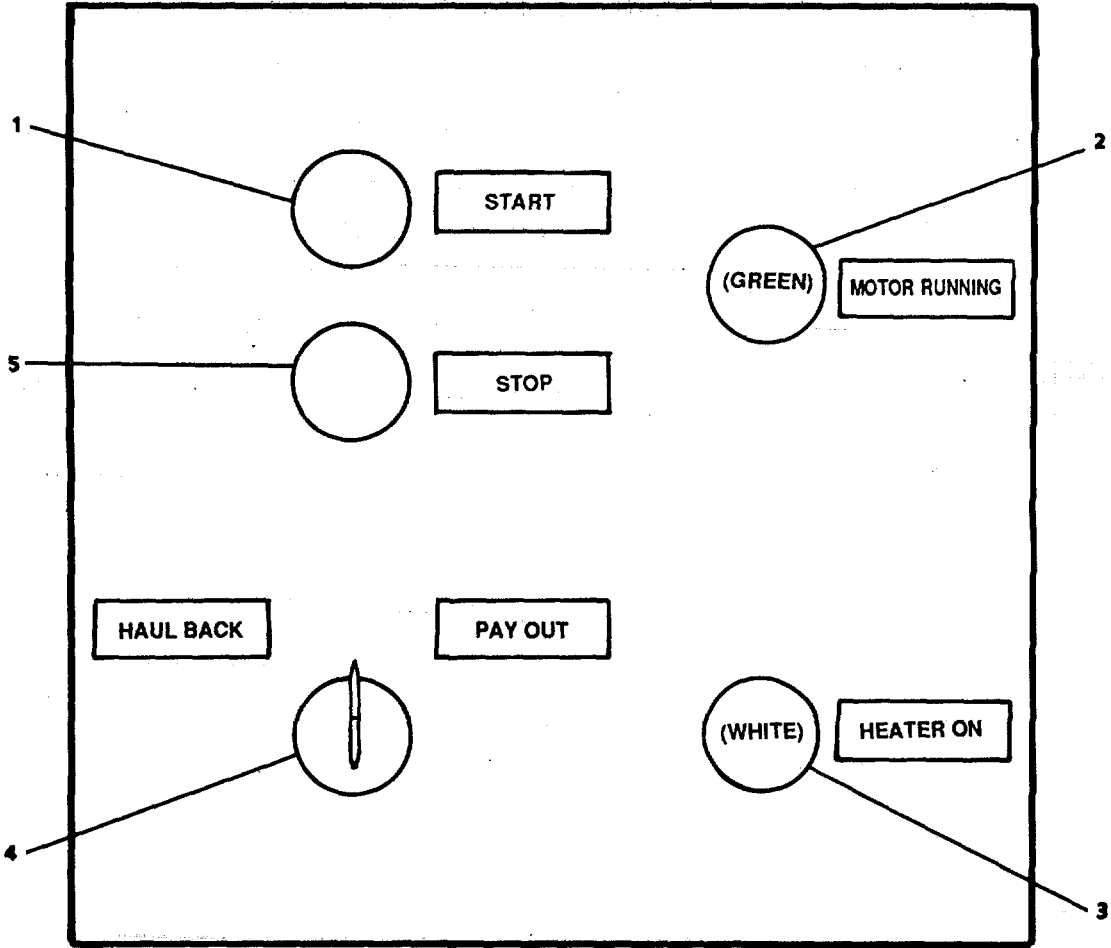

FIGURE 2-49. Bow Anchor Windlass (Sheer 1 of 3).

**Table 2-1. Description of Operator's Controls and Indicators - CONT**

Key	Control or Indicator	Function
Bow Anchor Windlass (FIGURE 2-49)		
1	START	Pushbutton starts bow windlass hydraulic pump motor (green).
2	MOTOR OPERATING	Indicates hydraulic pump motor is operating (red).
3	HEATER ON	Not used (white).
4	HAUL BACK/PAY OUT	Moving switch to PAY OUT, pays out anchor chain, lowering anchor. Moving switch to HAUL BACK hauls in anchor chain, raising anchor.
5	STOP	Pushbutton stops bow anchor windlass hydraulic pump motor (red).
6	Hydraulic Pressure Gauge	Indicates hydraulic pressure in bow anchor windlass system.
7	Fluid Level Sight Glass	Indicates fluid level and temperature of bow anchor windlass hydraulic fluid.
8	Filter Condition Indicator	Indicates when bow anchor windlass-hydraulic filter needs to be changed.
9	Clutch Lever	Engages/disengages clutch for operation.
10	Winch Brake	Controlled by hand brake wheel to secure bow winch drum.
11	Hand Brake Wheel	Applies manual brake to bow winch drum.
12	Wildcat	Hauls in and pays out anchor chain.
13	Cat Head	Auxiliary line handling drum used for warping vessel during mooring.
14	Fail Safe Brake	Locks brakes stopping main spool rotation when hydraulic pressure is lost.
15	Chain Stopper	When engaged, prevents anchor chain from moving down hawse pipe. When disengaged, permits anchor chain movement downward.

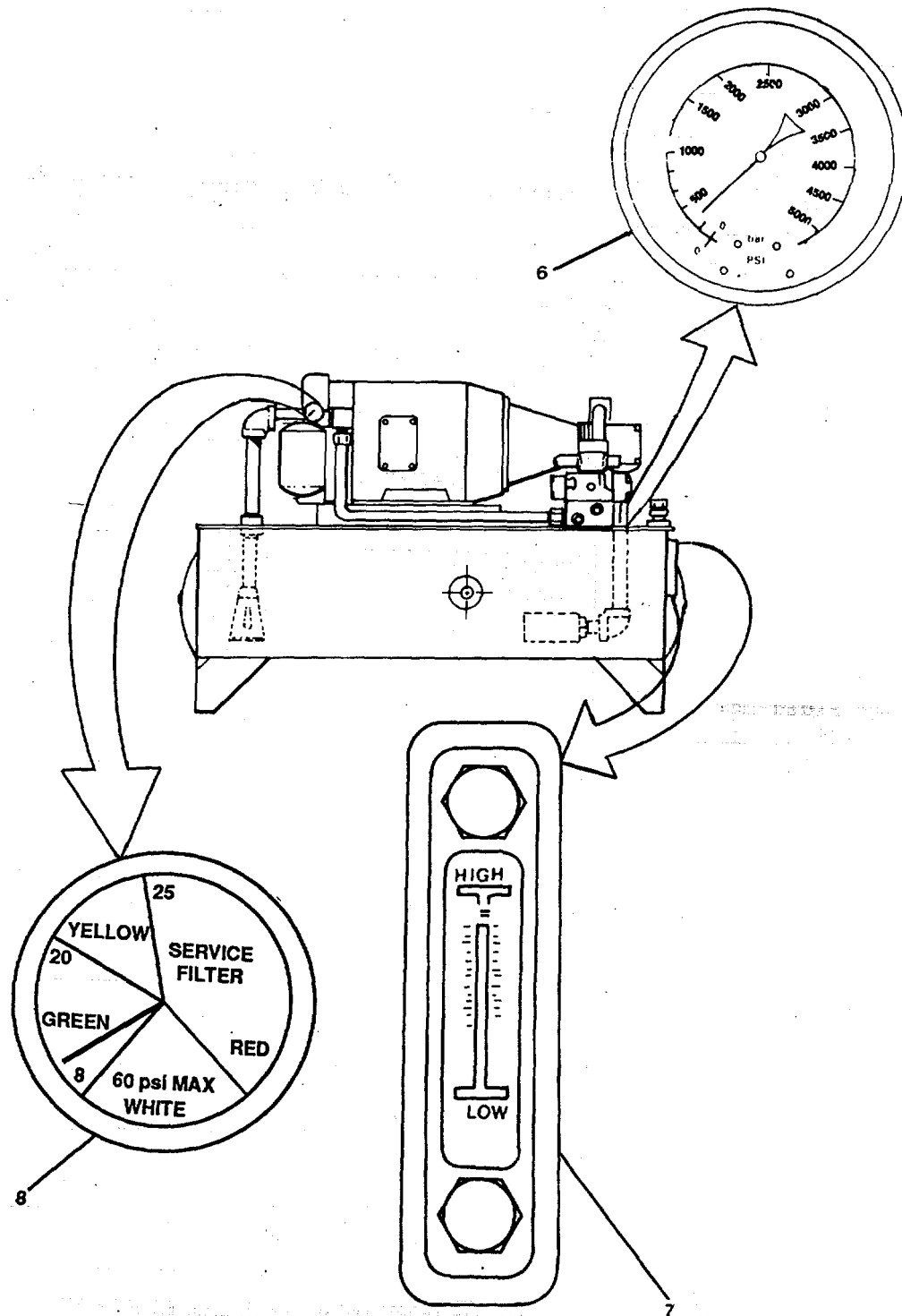

FIGURE 2-49. Bow Anchor Windlass (Sheer 2 of 3).

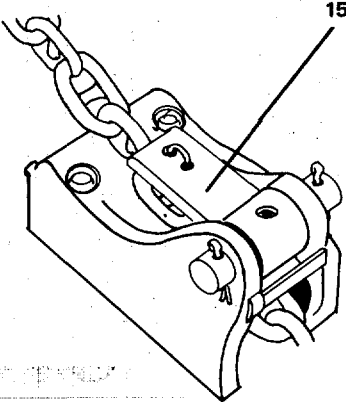
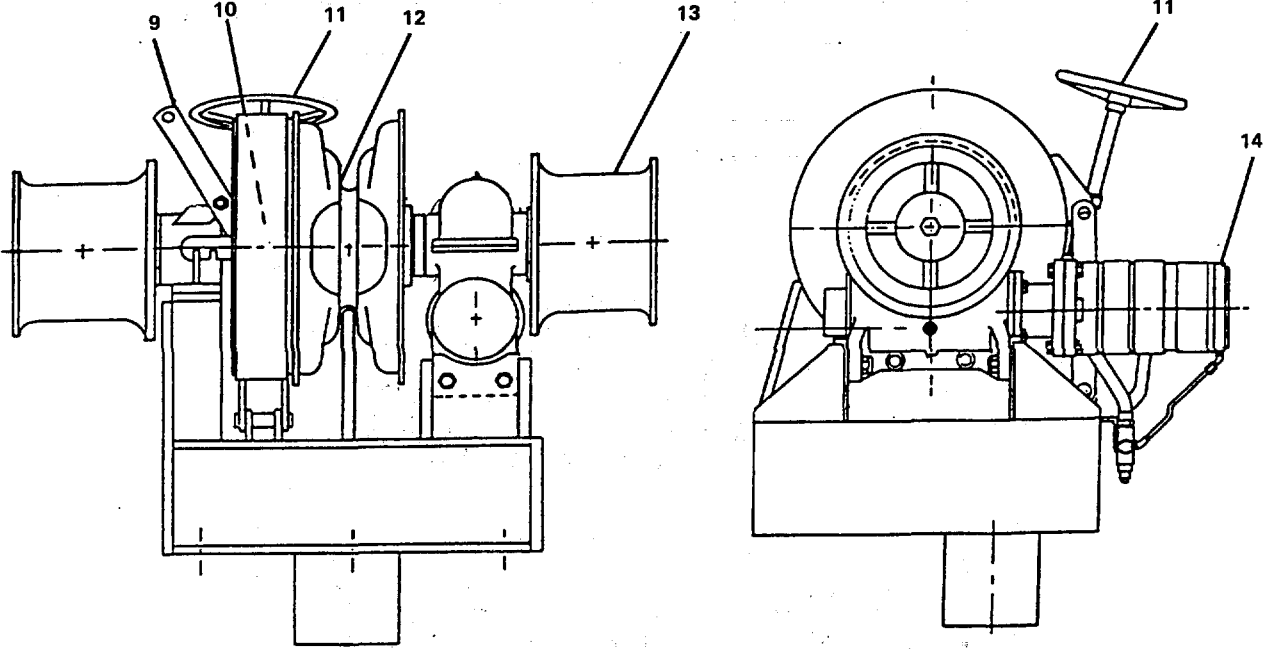
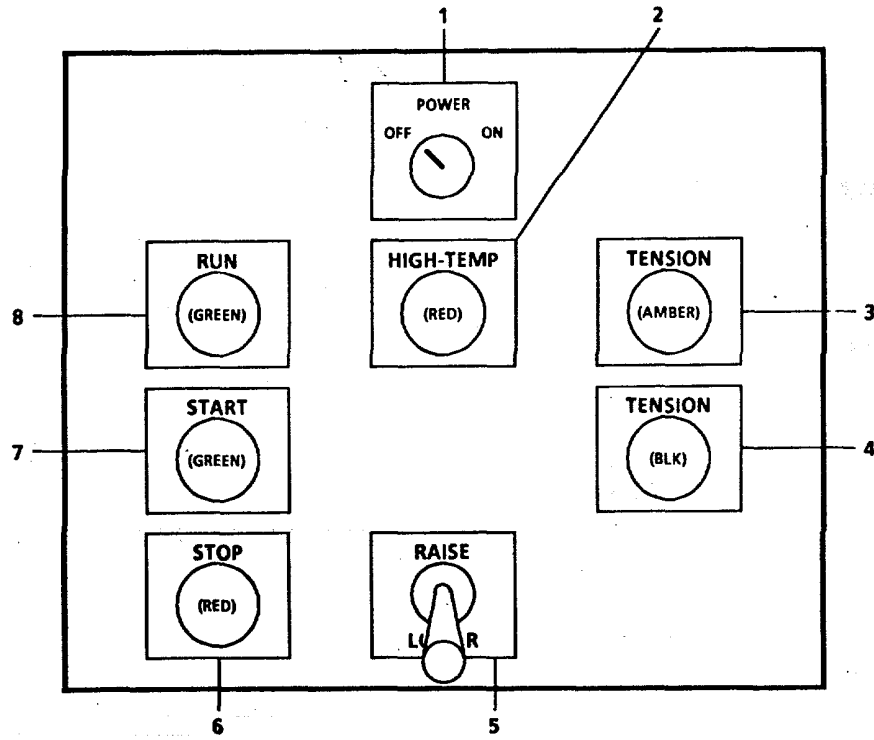
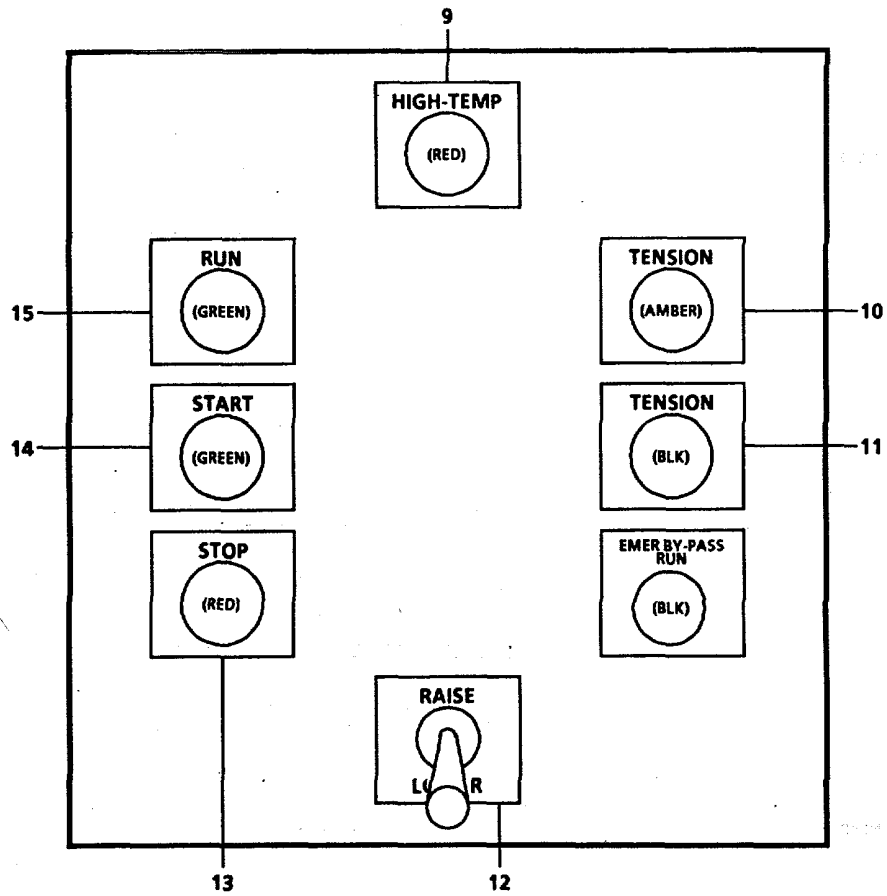

FIGURE 2-49. Bow Anchor Windlass (Sheer 3 of 3).



**PILOTHOUSE CONSOLE**



**BOATSWAINS LOCKER**

FIGURE 2-50. Bow Ramp System (Sheet 1 of 3).  
2-136

Table 2-1. Description of Operator's Controls and Indicators - CONT

Key	Control or Indicator	Function
Bow Ramp System (FIGURE 2-50)		
1	OFF-POWER-ON	Switch turns hydraulic pump OFF or ON.
2	HIGH TEMP	Indicates hydraulic fluid temperature is above normal (red).
3	TENSION	Indicates excessive slack in wire rope (amber).
4	TENSION	Pushbutton increases tension on wire rope.
5	RAISE-LOWER	Movement of control switch raises or lowers ramp.
6	STOP	Pushbutton stops hydraulic pump.
7	START	Pushbutton starts hydraulic pump.
8	RUN	Indicates hydraulic pump is operating (green).
9	HIGH TEMP	Indicates hydraulic fluid temperature in boatswain storeroom.
10	TENSION	Indicates excessive slack in wire rope (amber).
11	TENSION	Pushbutton increases tension on wire rope from the boatswain storeroom.
12	RAISE-LOWER	Movement of control switch raises or lowers ramp from boatswain storeroom.
13	STOP	Pushbutton stops hydraulic pump from boatswain storeroom.
14	START	Pushbutton starts hydraulic pump from boatswain storeroom.
15	RUN	Indicates hydraulic pump is operating in boatswain storeroom (green).



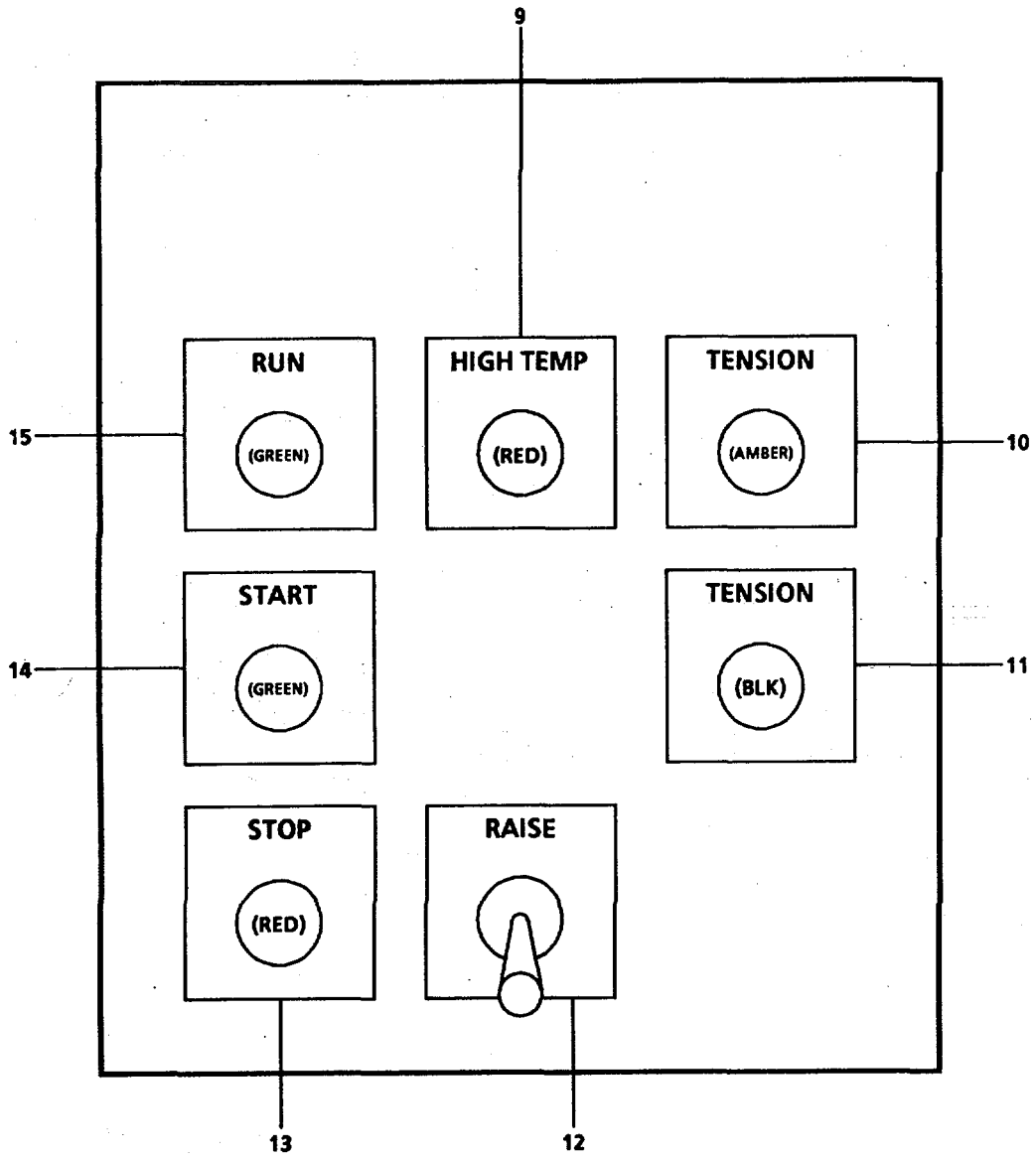

**FORECASTLE**

FIGURE 2-50. Bow Ramp System (Sheet 2 of 3).

Table 2-1. Description of Operator's Controls and Indicators - CONT

Key	Control or Indicator	Function
Bow Ramp System (FIGURE 2-50) - Continued		
16	Slack Wire Detector Bail	Provides signal to slack wire limit switch for excessive slack in wire rope.
17	Emergency Hand Crank	Hand crank used to manually raise and lower bow ramp.
18	Fluid Level Sight Glass	Indicates fluid level and temperature of hydraulic fluid.
19	Hydraulic Pressure	Indicates hydraulic pressure in bow ramp system.
20	Filter Condition	Indicates when bow ramp hydraulic fluid filter needs to be changed.

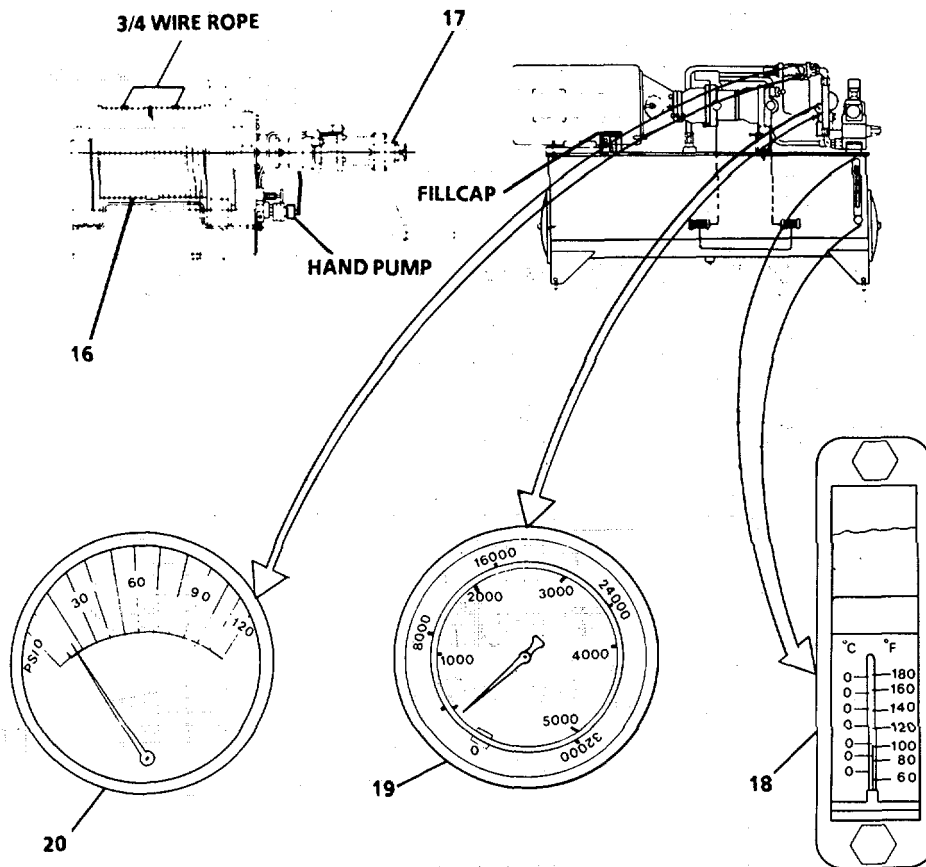

FIGURE 2-50. Bow Ramp System (Sheet 3 of 3).

Table 2-1. Description of Operator's Controls and Indicators - CONT

Key	Control or Indicator	Function
Bow Ramp Locking Assembly (FIGURE 2-51)		
1	Chain Stopper	To stop and hold chain for paying out.
2	Chain	Controls up and down movement of bow ramp.
3	Locking clamp	Holds bow ramp stud in up position.
4	Ratchet handle	Used to tighten locking assembly.
5	Chain stopper handle	Sets chain stopper or releases chain stopper.

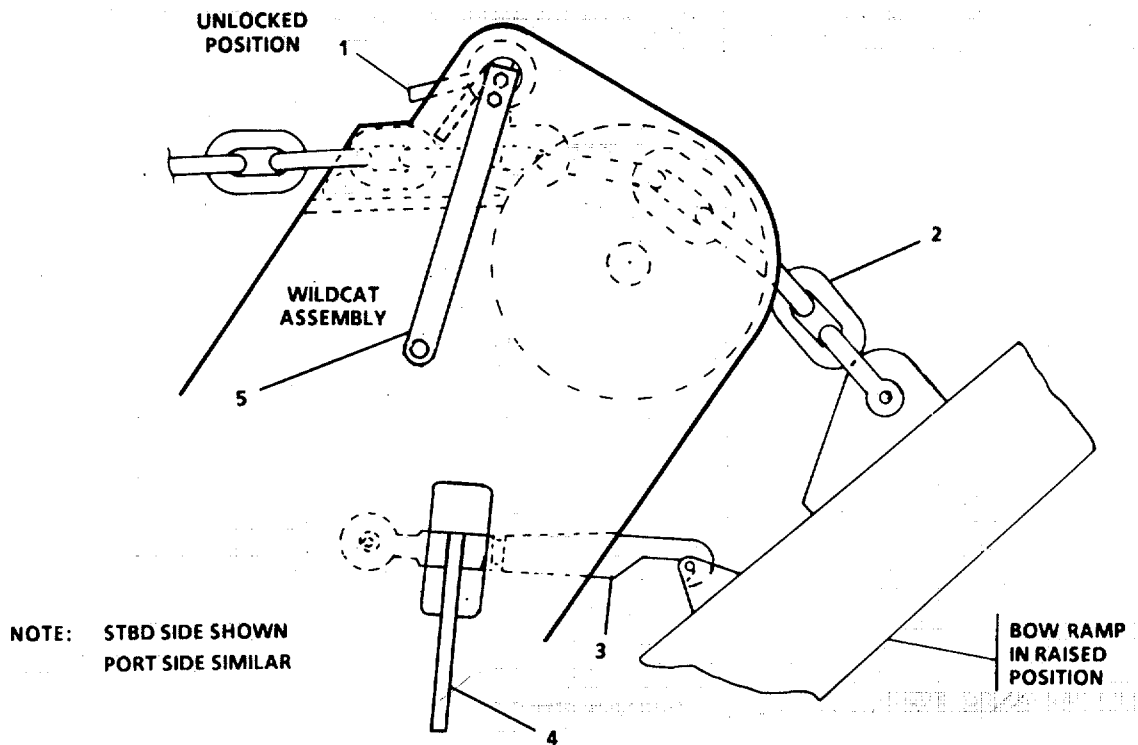

FIGURE 2-51. Bow Ramp Locking Assembly.

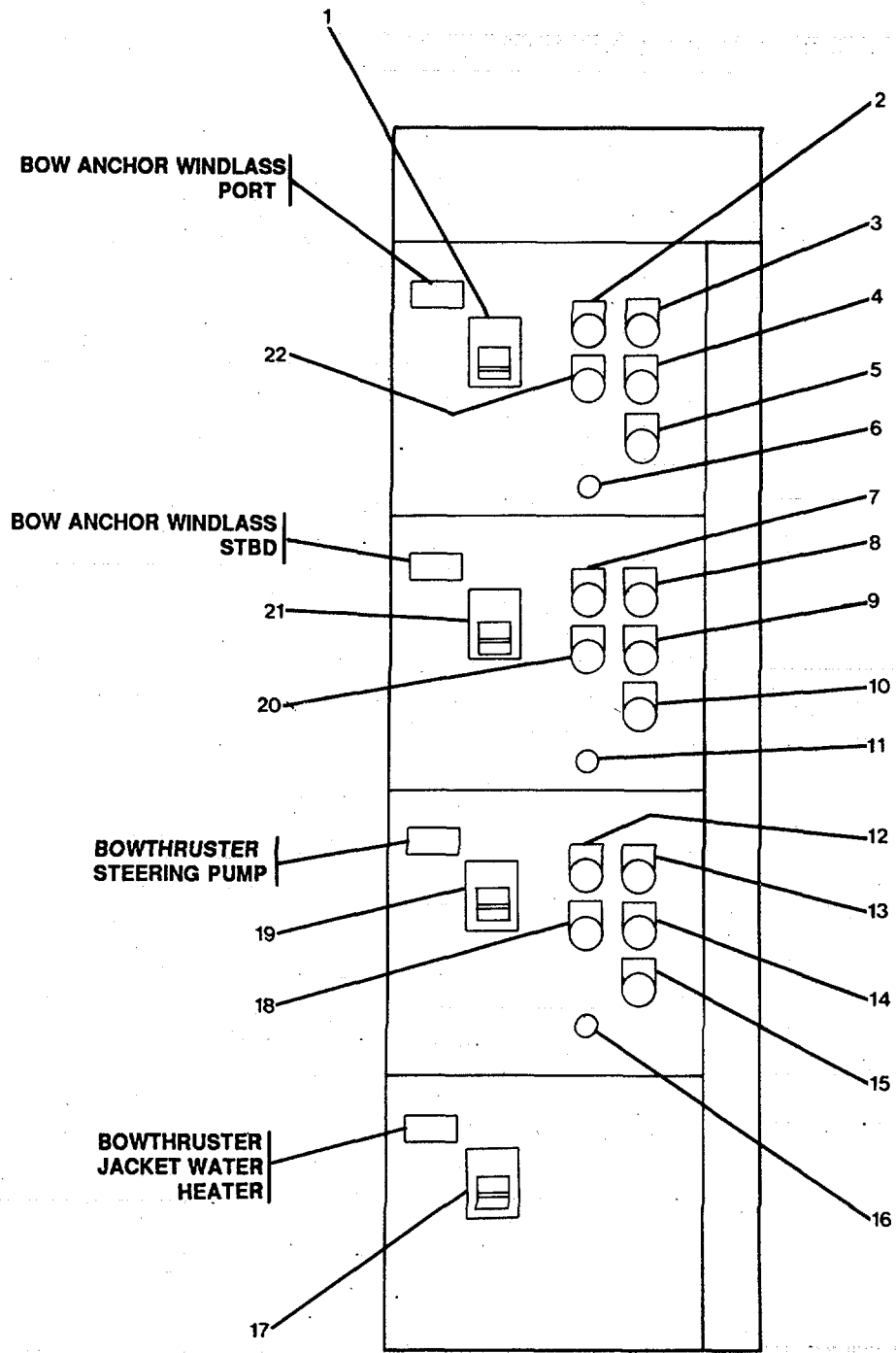

FIGURE 2-52. Forward Deck Machinery Motor Control Center.

(2-141 blank)/2-142

Table 2-1. Description of Operator's Controls and Indicators - CONT

Key	Control or Indicator	Function
Forward Deck Machinery Motor Control Center (FIGURE 2-52)		
1	P206-1	Protects port bow anchor windlass motor from amperage overload.'
2	MOTOR RUN	Indicates port bow anchor windlass motor is operating (.green).
3	MOTOR STOP	Indicates port bow anchor windlass motor is stopped (white).
4	STOP	Pushbutton stops port bow anchor windlass motor.
5	EMERGENCY RUN	Pushbutton operates port bow anchor windlass motor for time pushbutton is depressed.
6	RESET	Pushbutton resets port bow anchor windlass motor controller.
7	MOTOR RUN	Indicates starboard bow anchor windlass motor is operating (green).
8	MOTOR STOP	Indicates starboard bow anchor windlass motor is stopped (white).
9	STOP	Pushbutton stops starboard bow anchor windlass motor.
10	EMERGENCY RUN	Pushbutton operates starboard bow anchor windlass motor for time pushbutton is depressed.
11	RESET	Pushbutton resets starboard bow anchor windlass motor controller.
12	MOTOR RUN	Indicates bowthruster steering pump is operating (green).
13	MOTOR STOP	Indicates bowthruster steering pump is stopped (white).
14	STOP	Pushbutton stops bowthruster steering pump.
15	EMERGENCY RUN	Pushbutton operates bowthruster steering pump for time pushbutton is depressed.

Table 2-1. Description of Operator's Controls and Indicators - CONT

Key	Control or Indicator	Function
Forward Deck Machinery Motor Control Center (FIGURE 2-52) - Continued		
16	RESET	Pushbutton resets bowthruster steering pump motor controller.
17	P206-4	Protects bowthruster jacket water heater from amperage overload.
18	START	Pushbutton starts bowthruster steering pump.
19	P206-3	Protects bowthruster steering pump from amperage overload.
20	START	Pushbutton starts starboard bow anchor windlass motor.
21	P206-2	Protects starboard bow anchor windlass motor from amperage overload.
22	START	Pushbutton starts port bow anchor windlass

Table 2-1. Description of Operator's Controls and Indicators – CONT

Key	Control or Indicator	Function
<b>NOTE</b>		
<b>Not applicable to vessels with FM-200 Fire Suppressant System installed. Ref. para. 2-46 through 2-47, for FM-200 and Water Washdown System operation.</b>		
Surface Pull Box Halon 1301 Fire Suppression System (FIGURE 2-53)		
1	Glass Front	Protects pull handle from inadvertent operation.
2	Valve Release Pull Handle	Opens CO <sup>2</sup> discharge valve.
3	Hammer	Breaks glass for access to valve release pull handle.
4	Cylinder Release Pull Handle	Opens HALON discharge valve.

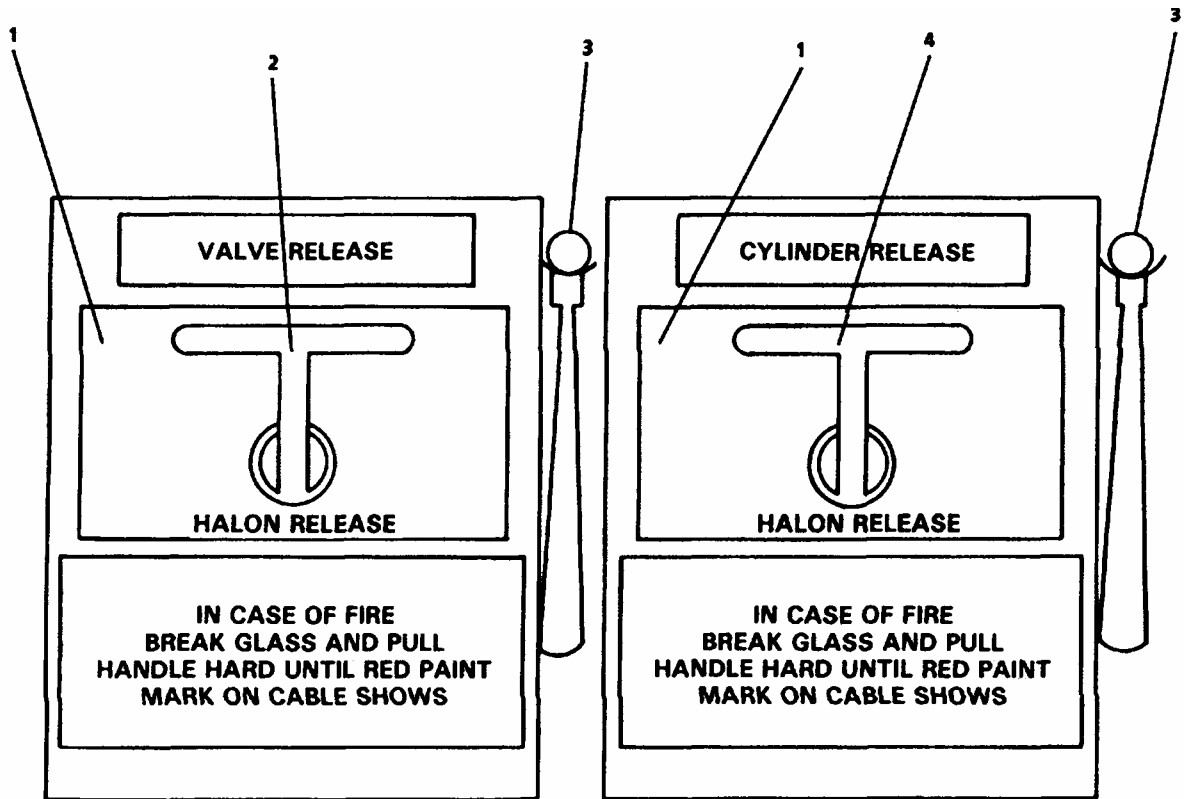

FIGURE 2-53. Surface Pull Box HALON 1301 Fire Suppression System.

Table 2-1. Description of Operator's Controls and Indicators - CONT

Key	Control or Indicator	Function
<b>NOTE</b>		
<p><b>Not applicable to vessels with FM-200 Fire Suppressant System installed. Ref. para. 2-46 through 2-47, for FM-200 and Water Washdown System operation.</b></p> <p>Lever Operated Control HALON 1301 Fire Suppression System (FIGURE 2-54)</p>		
1	Lever Release CO <sup>2</sup> Cylinder	Raise to release CO <sup>2</sup> charge.
2	Lever Operated Control	Mounted on carbon dioxide (CO <sup>2</sup> ) cylinder.

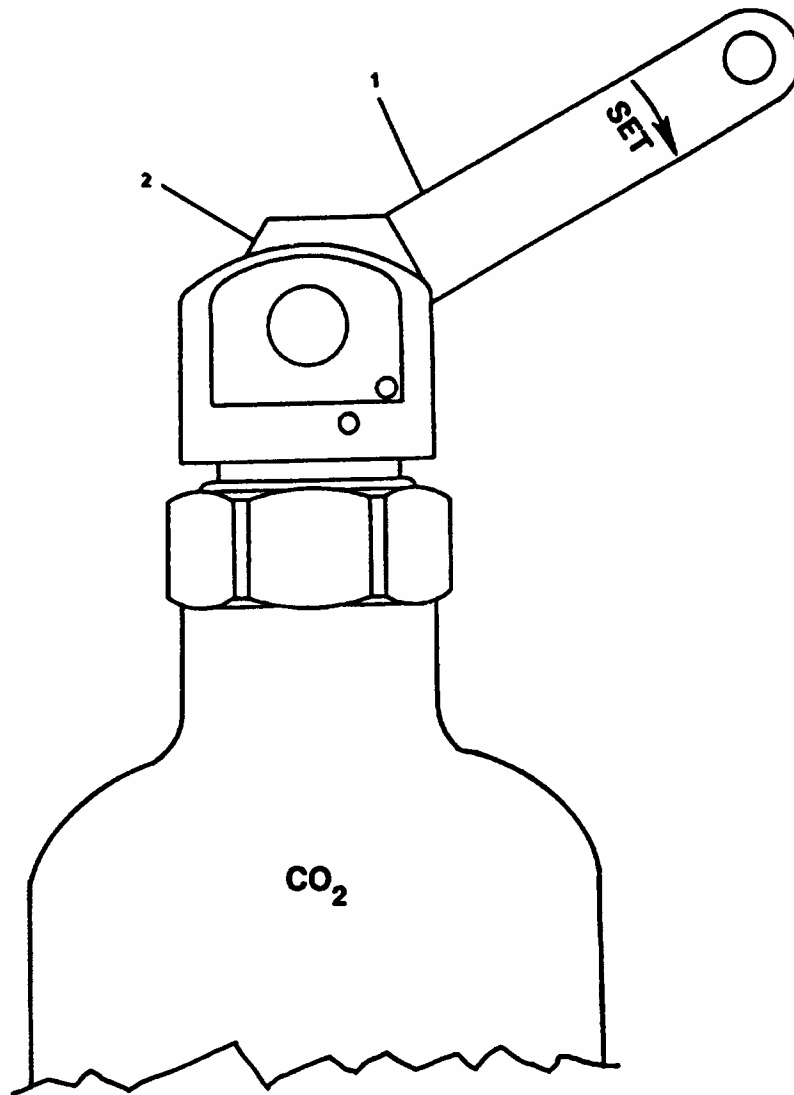

FIGURE 2-54. Lever Operated Control HALON 1301 Fire Suppression System.



Table 2-1. Description of Operator's Controls and Indicators – CONT

Key	Control or Indicator	Function
<p><b>NOTE</b></p> <p><b>Not applicable to vessels with FM-200 Fire Suppressant System installed. Ref. para. 2-46 through 2-47, for and Water Washdown System operation.</b></p> <p>Remote Lever Operated Control HALON 1301 Fire Suppression System (FIGURE 2-55)</p>		
1	Lever Control 1/2-Inch Glove Valve	Mounted in carbon dioxide (CO
2	Lever Release	Raise to operate glove valve (1) and release CO <sup>2</sup> charge.

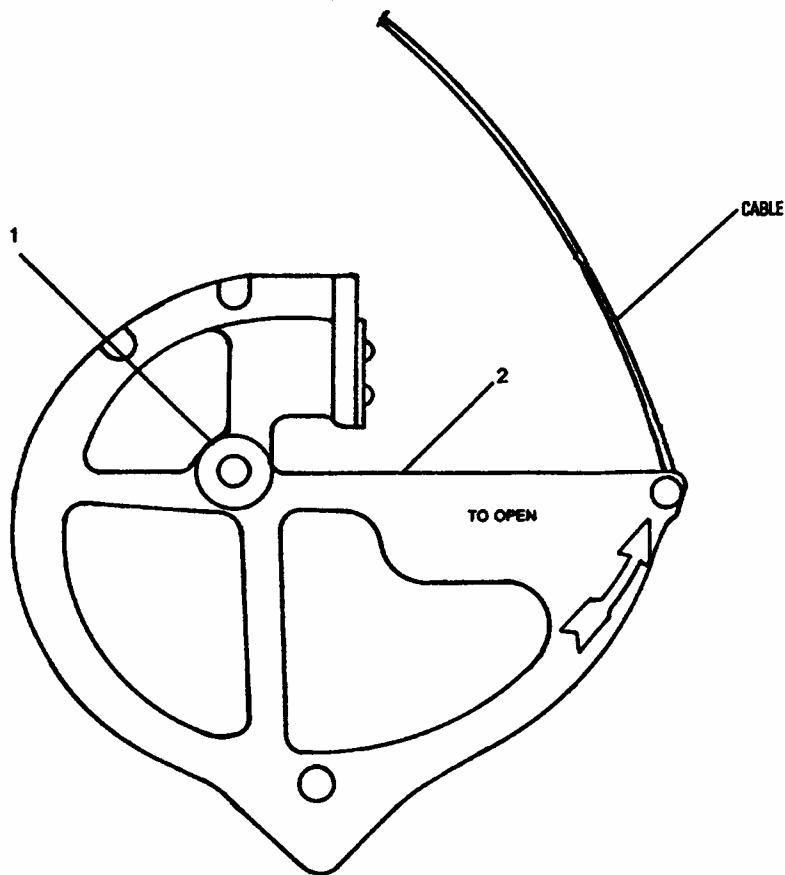

FIGURE 2-55. Remote Lever Operated Control HALON 1301 Fire Suppression System.

Table 2-1. Description of Operator's Controls and Indicators – CONT

Key	Control or Indicator	Function
<p><b>NOTE</b></p> <p><b>Not applicable to vessels with FM-200 Fire Suppressant System installed. Ref. para. 2-46 through 2-47, for and Water Washdown System operation.</b></p> <p>Pneumatic Switch HALON 1301 Fire Suppression System (FIGURE 2-56)</p>		
1	Reset Plunger	Resets fire suppression system after discharge.

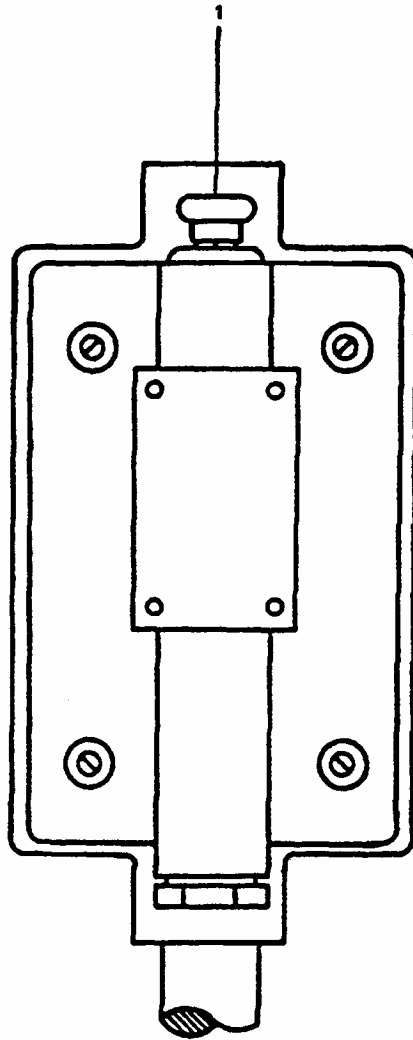

FIGURE 2-56. Pneumatic Switch HALON 1301 Fire Suppression System.

Table 2-1. Description of Operator's Controls and Indicators - CONT

Key	Control or Indicator	Function
Fire Station (FIGURE 2-57)		
1	Valve	Turns pressurized water ON or OFF.
2	Nozzle	Directs water by spray or straight stream to fire.

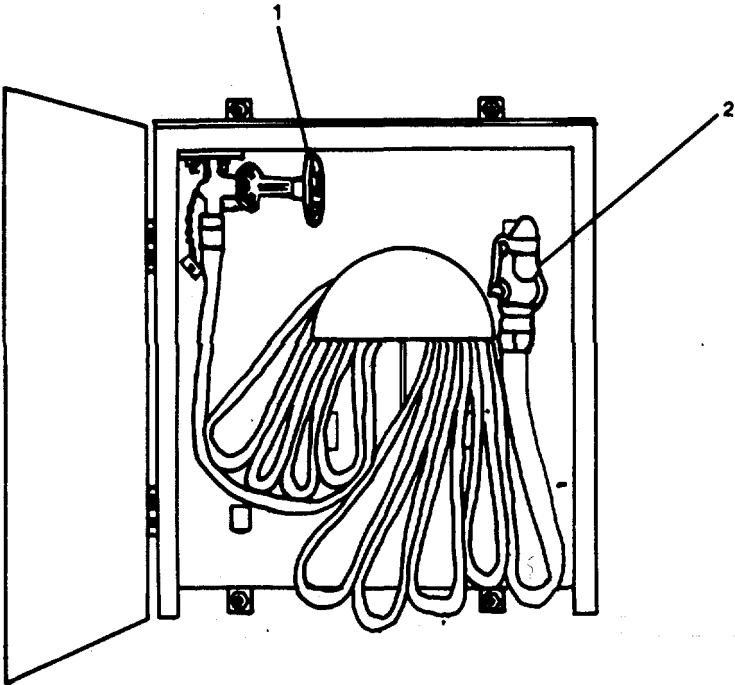

FIGURE 2-57. Fire Station.

Table 2-1. Description of Operator's Controls and Indicators - CONT

Key	Control or Indicator	Function
Oxygen Breathing Apparatus (OBA) (FIGURE 2-58)		
1	Timer	Provides a check of time remaining. Timer bell will ring for 8-10 seconds continuously.
2	Pressure Relief Valve and Pull Tab	Vents overpressure automatically. Tab provides manual release.
3	Canister Release Tab	Releases canister from harness.
4	Canister Seal	Protects chemicals from moisture until canister is ready for use.
5	Candle Cover	Protects candle when not in use.
6	Lanyard	Releases candle firing pin when pulled.

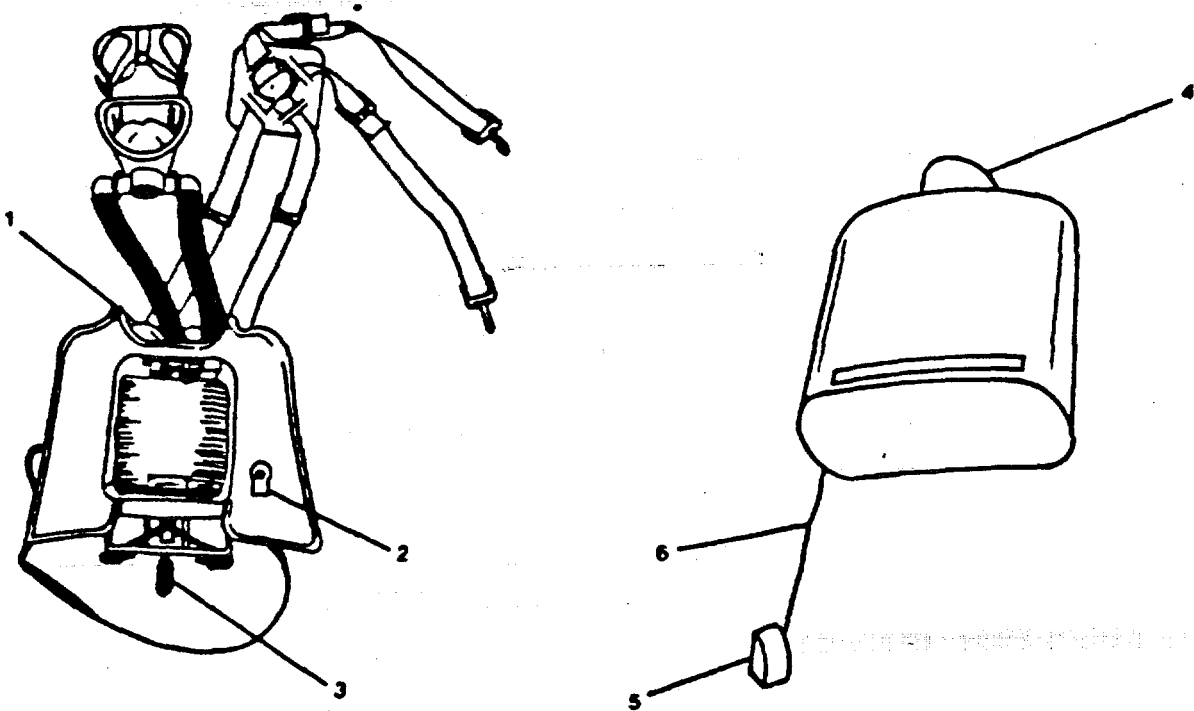

FIGURE 2-58. Oxygen Breathing Apparatus (OBA).

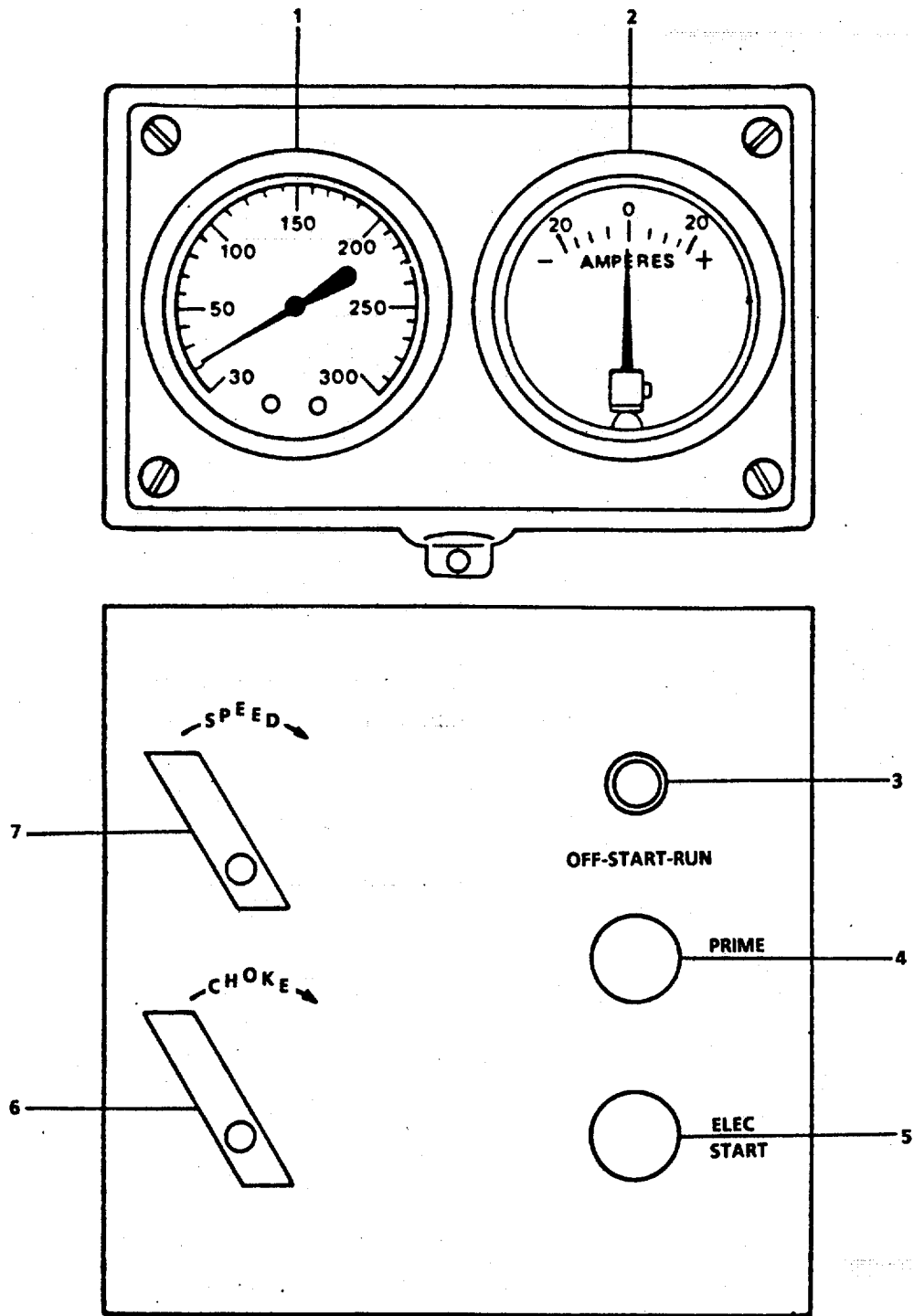

FIGURE 2-59. Portable Fire Pump (P-250) (Sheet 1 of 3)

(2-151 blank)/2-152

Table 2-1. Description of Operator's Controls and Indicators - CONT

Key	Control or Indicator	Function
Portable Fire Pump (P-250) (FIGURE 2-59)		
1	Pressure Gauge	Indicates pump pressure, or pump vacuum when priming.
2	AMPERES Gauge	Indicates if alternator is charging or discharging.
3	OFF-START-RUN	Switch turns engine off in OFF, allows engine to start in START, and allows engine to run in RUN position and prevents over speed of engine if prime is lost.
4	PRIME	Pushbutton to put pump in priming mode.
5	START	Pushbutton to place engine in starting mode with OFF-START-RUN switch in START position.
6	CHOKE	Controls carburetor fuel/air mixture.
7	SPEED	Controls speed of engine.
8	Suction Hose Connection with Cover	Provides connection for suction hose.
9	Water Discharge Valve	In closed position and PRIME pushbutton depressed, pump is in priming mode. In open position, pump can discharge water.
10	Discharge Hose Connection with Cover	Provides connection for discharge hose.
11	Priming Pump Discharge Port	Discharges output of pump.
12	Manual Priming Inlet Plug	To manually prime pump when lift is greater than 20 feet.
13	Pump Drain Valve	When open, drains water from pump.
14	Manual Start Pull Cord	Provides emergency engine starting.
15	External Fuel Tank	Provides fuel for pump engine.

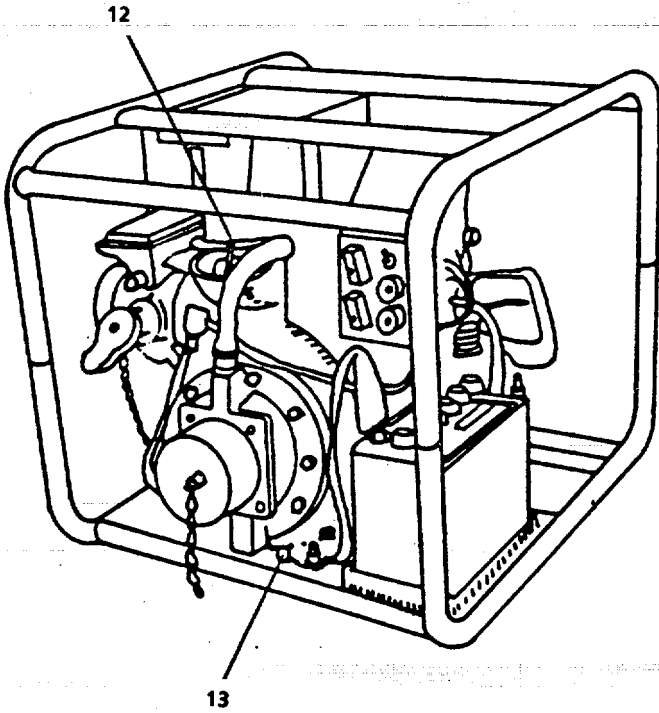
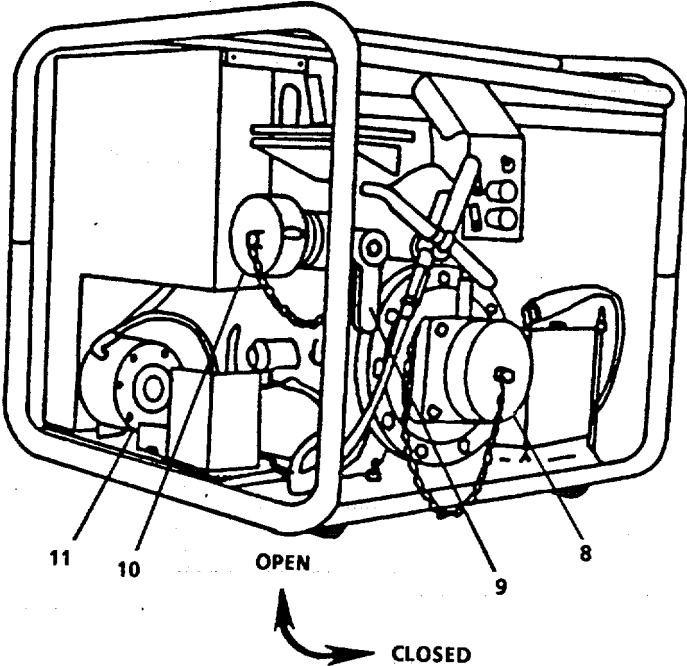

FIGURE 2-59. Portable Fire Pump (P-250) (Sheet 2 of 3).

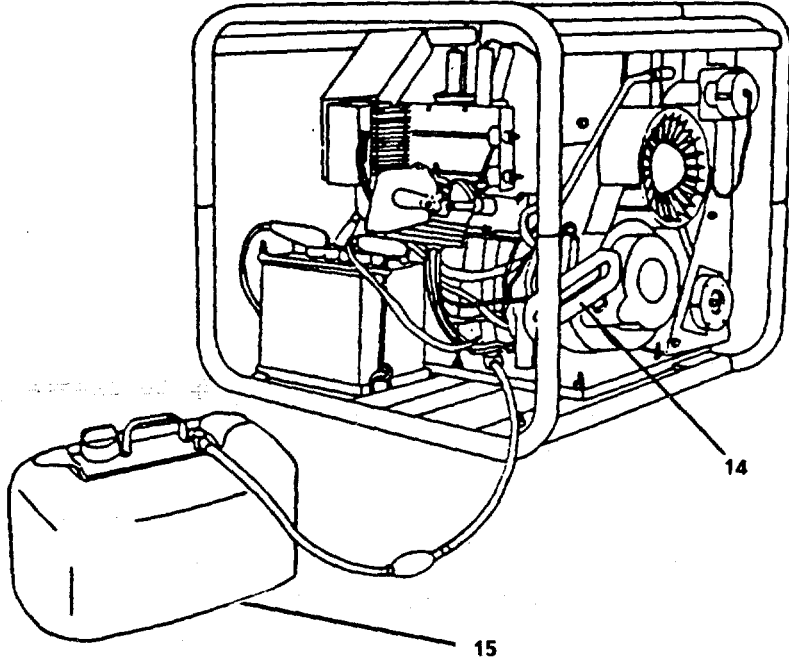

FIGURE 2-59. Portable Fire Pump (P-250) (Sheet 3 of 3).



Table 2-1. Description of Operator's Controls and Indicators - CONT

Key	Control or Indicator	Function
Liferaft (FIGURE 2-60)		
1	Liferaft Container	Contains liferaft and CO2 bottle.
2	Pressure Release Strap	Releases top and bottom halves of container when liferaft inflates.
3	Retainer Strap	Holds container to liferaft cradle.
4	Locking Ring	Holds pelican hook in closed position.
5	Pelican Hook	Attaches hook at end of retaining strap to cradle.
6	Hydrostatic Release	Causes automatic inflation of liferaft in container when submerged.
7	Thimble	Protects rope from fraying.
8	Cradle Shackle	A device to secure strap to cradle.
9	Cradle	Secure platform for liferaft.
10	Launch Ramp	Provides area for launching liferaft.
11	Painter Line	Attached to launch ramp, causes automatic liferaft inflation.

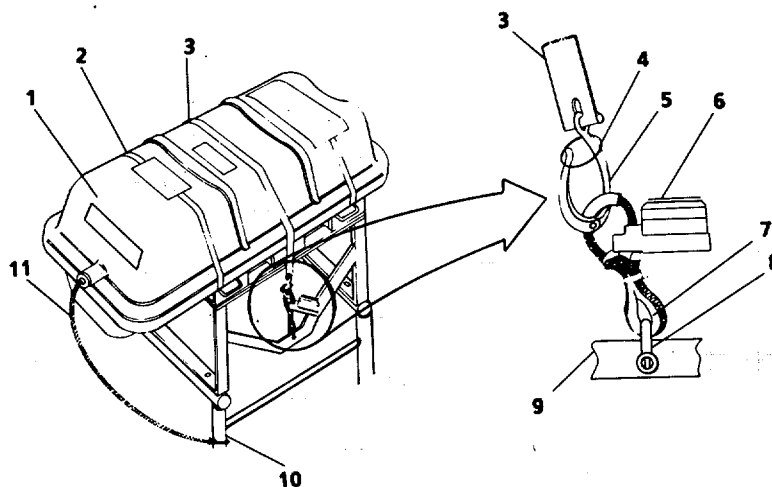

FIGURE 2-60. Liferaft.

**Table 2-1. Description of Operator's Controls and Indicators - CONT**

Key	Control or Indicator	Function
Rescue/Workboat and Motor (FIGURE 2-61)		
1	SLING	Device to lift rescue/workboat.
2	FIBERGLASS MOLDED BOTTOM	Ridged bottom of boat.
3	TILLER ARM AND THROTTLE	Used to steer boat and control speed.
4	MOTOR MOUNT BRACKET	To secure motor to the boat transom.
5	GEAR SHIFT LEVER	Controls forward and reverse operation of the motor.
6	INFLATED CHAMBER	Inflatable chamber for stability.

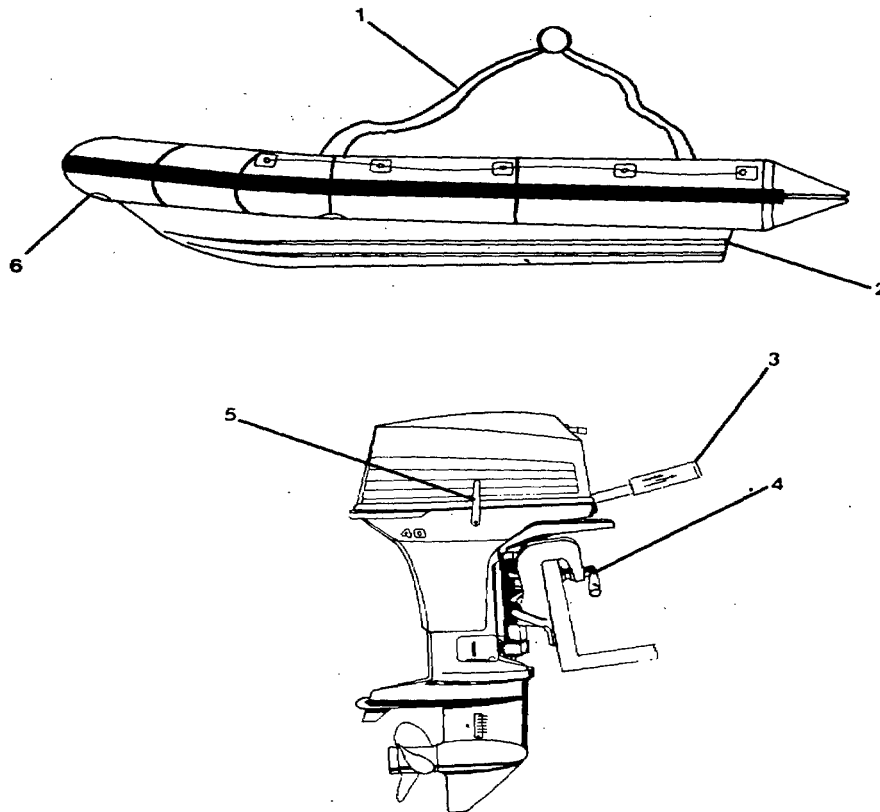

FIGURE 2-61. Rescue/Workboat and Motor.

Table 2-1. Description of Operator's Controls and Indicators - CONT

Key	Control or Indicator	Function
Rescue/Workboat Crane (FIGURE 2-62)		
1	Hook	Provides connection to load.
2	Cradle	To hold remote control unit.
3	Cable	Cable for remote control unit.
4	UP	Pushbutton raises hook cable.
5	DOWN	Pushbutton lowers hook cable.
6	Remote Control	Provides control of hook cable.
7	Motor Controller	OFF-ON control for power unit.
8	Hand Crank	Provides crane with 360' non-continuous horizontal rotation.
9	Power Cord	Connection between motor controller and power junction box.

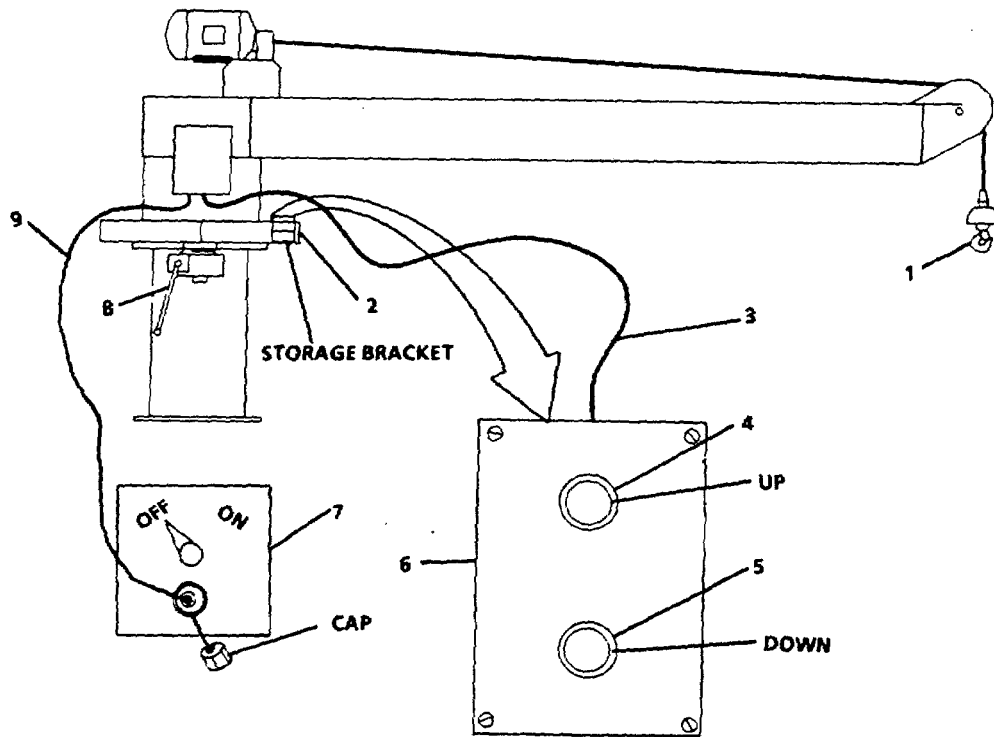

FIGURE 2-62. Rescue/Workboat Crane.

Table 2-1. Description of Operator's Controls and Indicators - CONT

Key	Control or Indicator	Function
Bench Grinder (FIGURE 2-63)		
<b>WARNING</b>		
Eye protection shield does NOT replace the face-eye protection, operator MUST wear while using this equipment.		
1	Eye Shield Protection	Protects operator from sparks and debris while allowing observation of grinding.
2	Grinder Wheel	Rotating grinder disk.
3	Tool Rest	Supports tool or item being worked on.
4	ON/OFF Switch	Controls electrical power to unit.

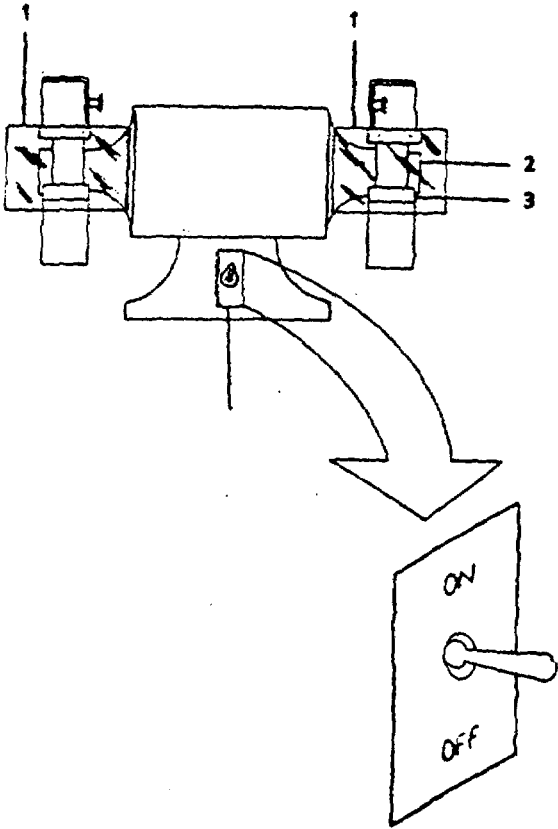

FIGURE 2-63. Bench Grinder.

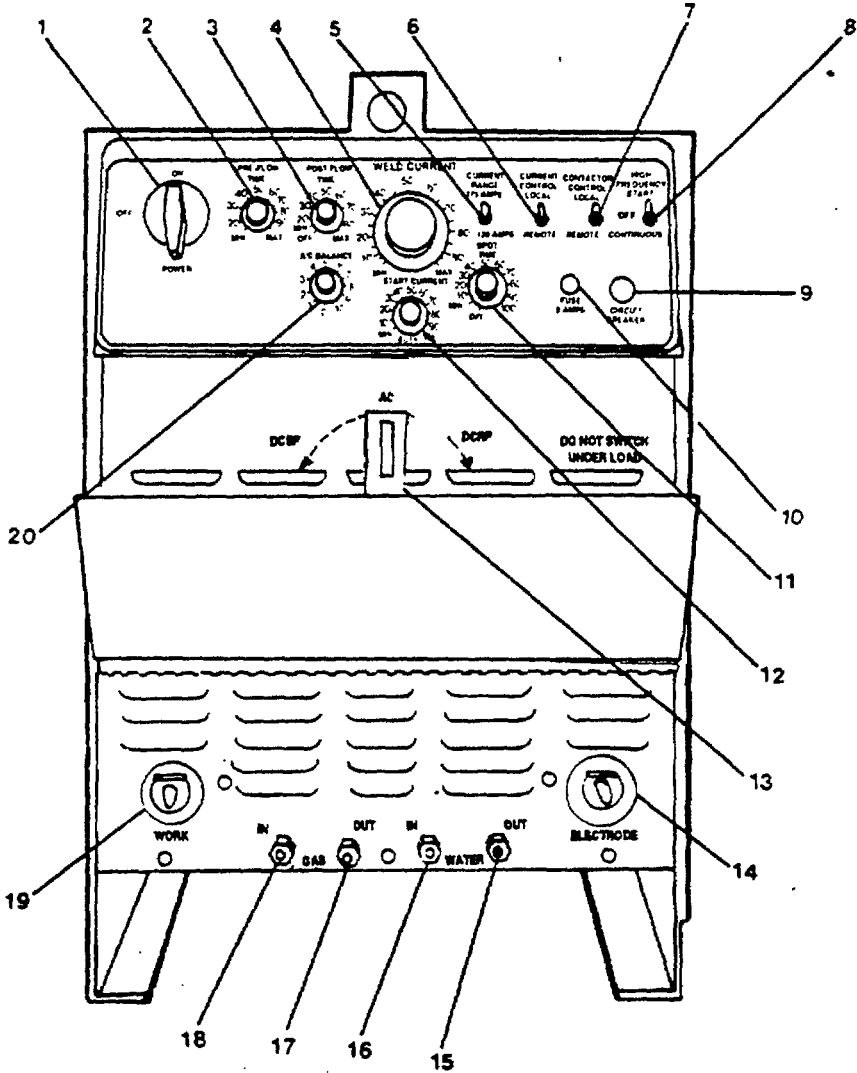

FIGURE 2-64. Electric Welding Machine.

Table 2-1. Description of Operator's Controls and Indicators - CONT

Key	Control or Indicator	Function
Electric Welding Machine (FIGURE 2-64)		
1	POWER-OFF-ON	Controls the welding machine fan and control circuitry, and places the welding machine in a ready-to-weld status.
2	PRE-FLOW TIME	Provides a gas/water pre-flow potentiometer for purging the torch and weld area of atmospheric contaminants. Range of timer is from 0 to 10 seconds.
3	POST-FLOW TIME	Provides a switched potentiometer to control gas and water post-flow to shield molten metal from atmospheric contaminants. Post-flow can be set from 5 to 50 seconds.
4	WELD CURRENT	Provides a means of selecting the exact weld current desired within the range being used.
5	CURRENT RANGE	Provides the capability of selecting from two amperage ranges. High range covers 5 to 375 amperes, and low range covers 5 to 125 amperes.
6	CURRENT CONTROL	Provides local or remote control of amperage desired.
7	CONTACTOR CONTROL	Provides local or remote control of both the contactor and gas and water.
8	HIGH FREQUENCY	Provides a dual function: to enable starting the arc in gas tungsten arc welding (TIG) without touching the electrode to the work, and to stabilize the arc during welding operation.
9	CIRCUIT BREAKER	Provides 10-ampere circuit breaker protection for control panel.
10	FUSE 2 AMPS	Provides 2-ampere fuse protection for control panel.
11	SPOT TIME	Allows operator to set time for use of welding machine in spot weld mode.

**Table 2-1. Description of Operator's Controls and Indicators - CONT**

Key	Control or Indicator	Function
Electric Welding Machine (FIGURE 2-64) - continued		
12	START CURRENT	Provides starting current selection, which is in effect for approximately the first second of the weld. After this time period, the weld current goes to the setting of the weld current control.
13	DCSP AC DCRP	Switch selects either ac (AC), dc straight (DCSP), or dc reverse polarity (DCRP) without changing the secondary cable connections.
14	ELECTRODE	Terminal to contact the electrode holder to the welding machine.
15	WATER OUT	Provide fresh water cooling for the electrode holder.
16	IN WATER	Supply connection for fresh water for the electrode holder cooling system.
17	GAS OUT	Provides gas (argon or helium) to the electrode holder.
18	IN GAS	Supply connection for gas to the welding machine.
19	WORK	Terminal to connect the WORK or ground cable between the welding machine and the item being welded.
20	A/C BALANCE	Rotate control clockwise from the 50/50 balance to more straight polarity, less tungsten heating results and higher welding current may be applied to obtain more penetration. Rotate control counterclockwise toward 50/50 balance point, more reverse polarity, more tungsten heating and cleaning action are provided.

**Table 2-1. Description of Operator's Controls and Indicators - CONT**

Key	Control or Indicator	Function
Clothes Dryer Panel (FIGURE 2-65)		
1	FABRIC SELECTOR	Select dryer temperature for normal or delicate fabrics.
2	PUSH-TO-START	Pushbutton activates dryer.
3	IN USE	Indicates dryer in operation (red).
4	TIMER	Controls dryer operating time.

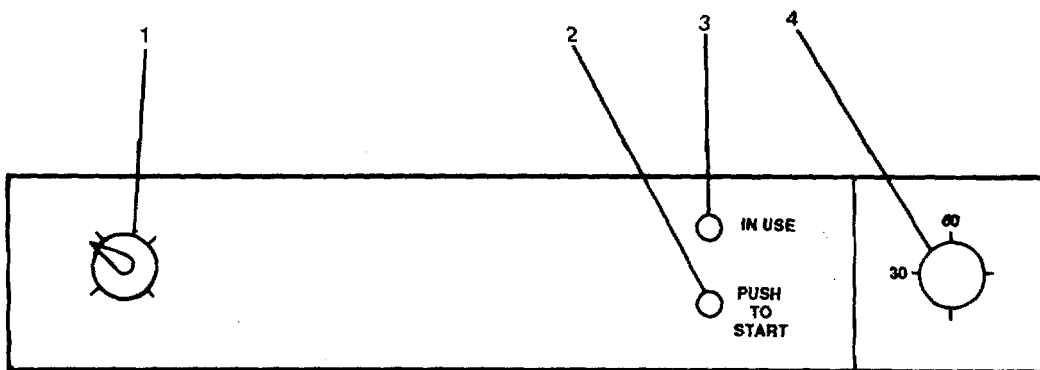

FIGURE 2-65. Clothes Dryer Panel.

(2-163 blank)/2-164



**Table 2-1. Description of Operator's Controls and Indicators - CONT**

Key	Control or Indicator	Function
Clothes Washer Panel (FIGURE 2-66)		
1	TEMPERATURE	Controls wash water temperature.
2	SPEED	Selects normal or delicate wash cycles.
3	UNBALANCED LOAD	Indicates unbalanced load condition (red).
4	IN USE	Indicates washer is operating.
5	TIMER	Controls washer activation as desired.
6	SPIN	Indicates washer in spin mode of operation (red).
7	RINSE	Indicates washer in rinse mode of operation (green).

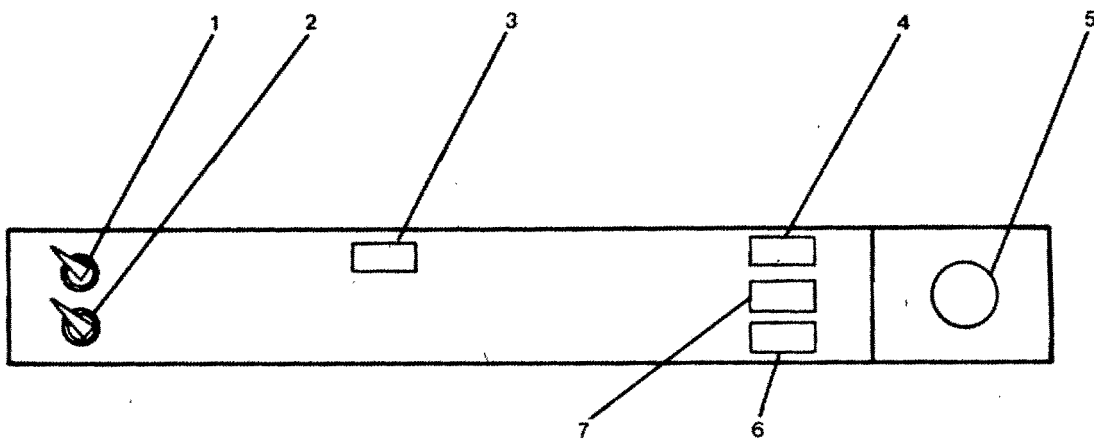

FIGURE 2-66. Clothes Washer Panel.

**Table 2-1. Description of Operator's Controls and Indicators - CONT**

Key	Control or Indicator	Function
Dishwasher (FIGURE 2-67)		
1	WASH START FILL	Switch activates start of wash cycle.
2	ON-OFF HEAT	Switch controls electrical power to dishwasher.
3	RINSE TEMP. 100°F MIN -24 SEC.	Indicates temperature of final rinse water.
4	RINSE FLOW PRES. 20 PSI	Indicates pressure of final rinse water.
5	WASH TEMP. 150°F MIN -93 SEC.	Indicates temperature of wash tank water.

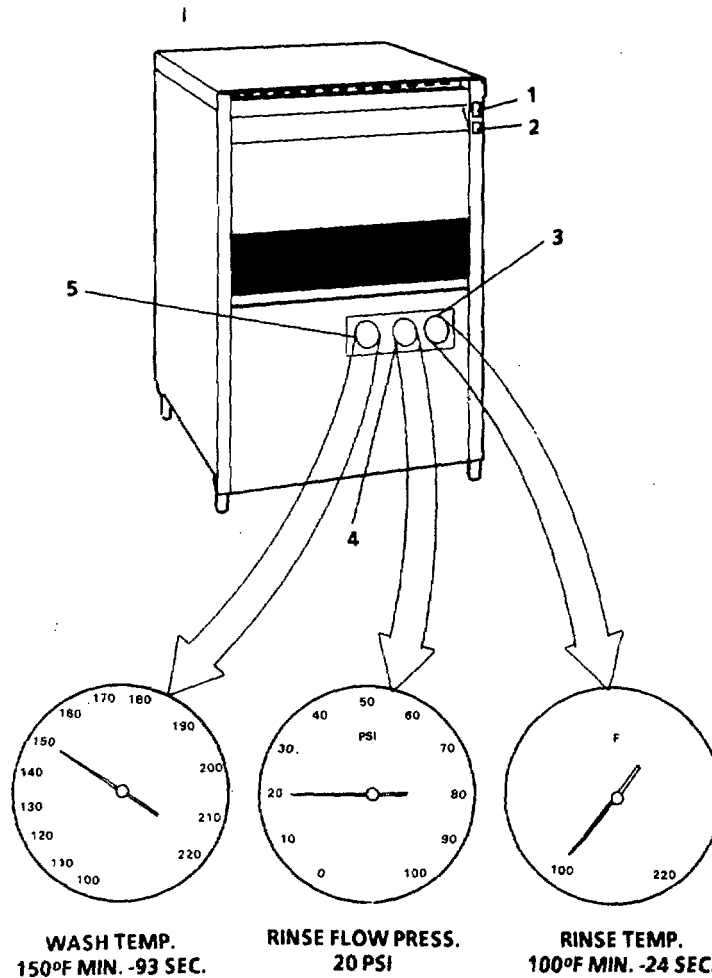

FIGURE 2-67. Dishwasher.

Table 2-1. Description of Operator's Controls and Indicators - CONT

Key	Control or Indicator	Function
Electric Griddle (FIGURE 2-68)		
1	Left Side Temperature Control	Controls left side grill temperature.
2	Right Side Temperature Control	Controls right side grill temperature.
3	Heating Indicator Lights	Indicates left or right heating elements are powered (red).

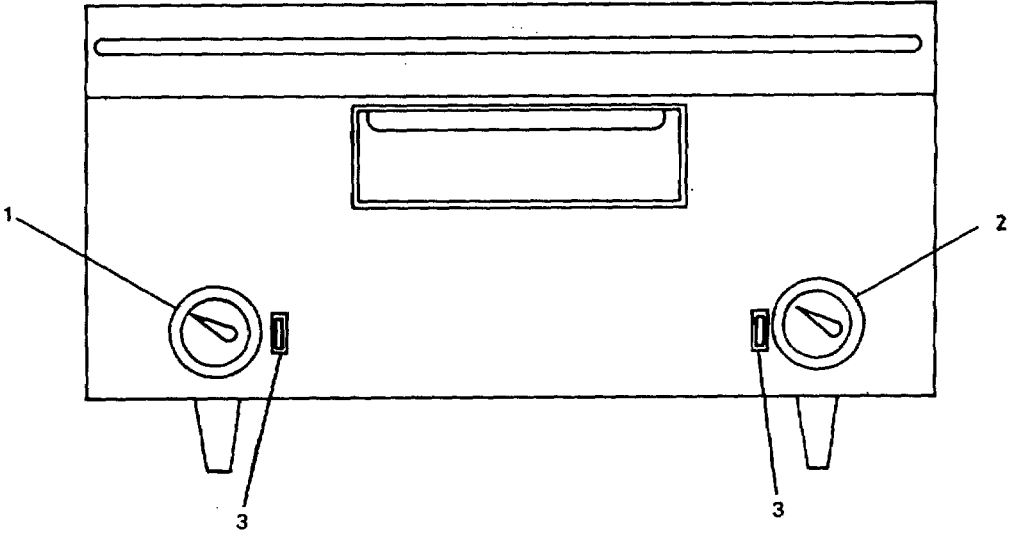
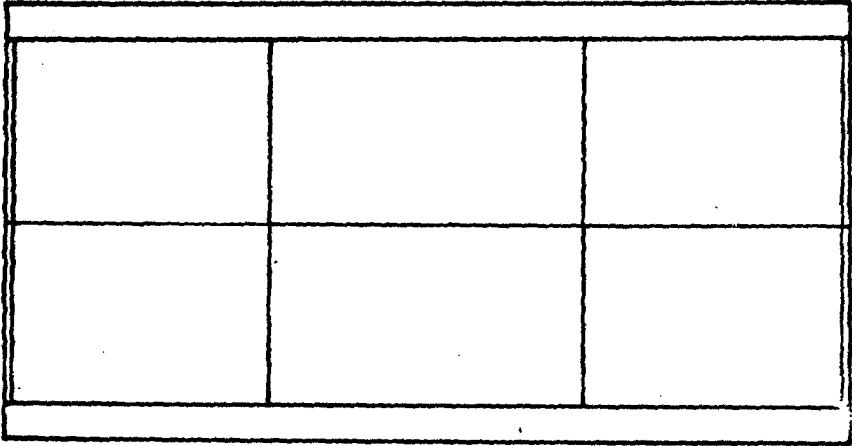
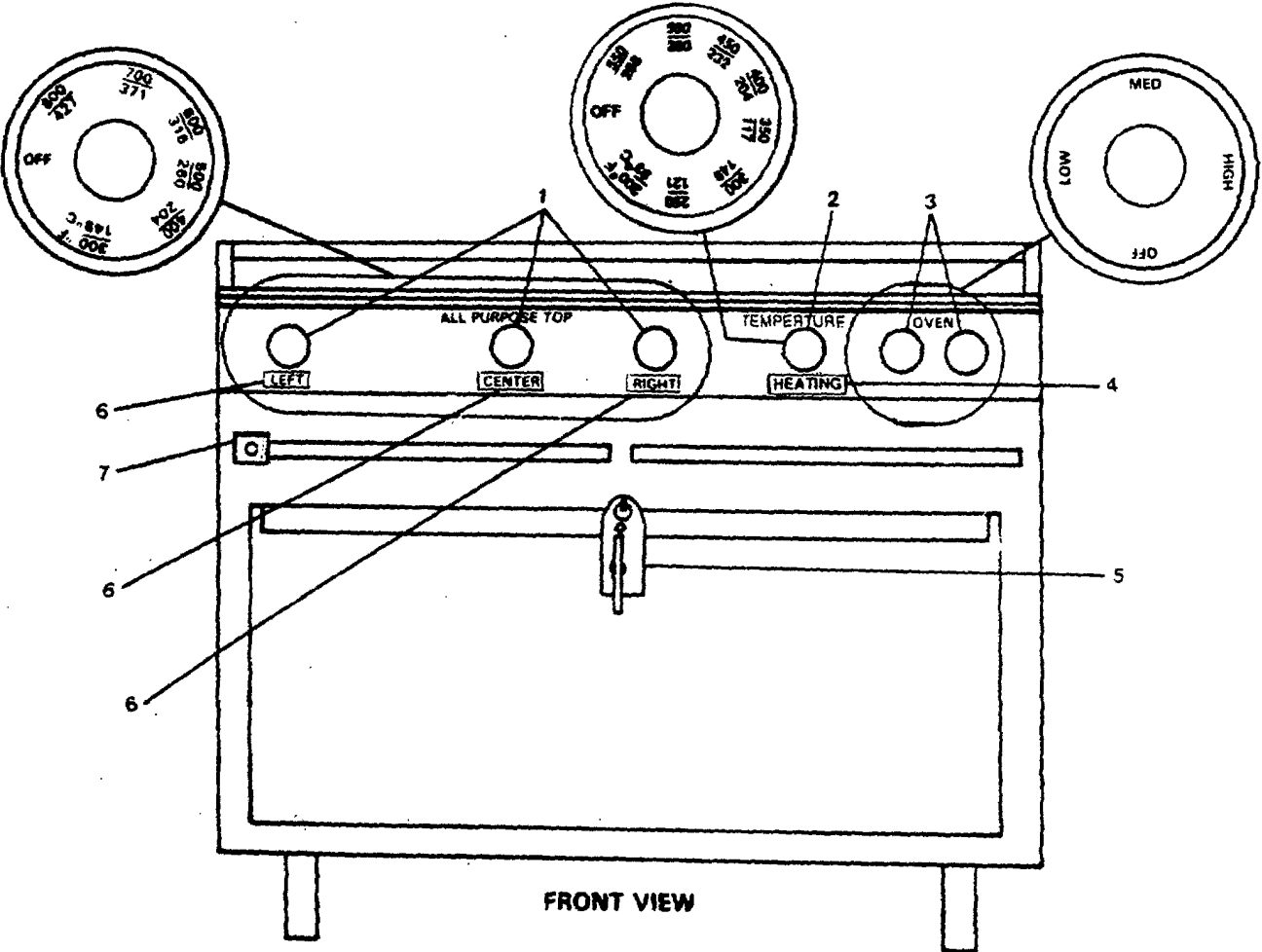

FIGURE 2-68. Electric Griddle.



TOP VIEW



FRONT VIEW

FIGURE 2-69. Marine Electric Range.

**Table 2-1. Description of Operator's Controls and Indicators - CONT**

Key	Control or Indicator	Function
Marine Electric Range (FIGURE 2-69)		
1	Control Dial	Controls temperature of electric range top heating elements.
2	Oven Temperature Control	Controls temperature of deck oven.
3	OVEN	Controls upper and lower oven heating elements.
4	HEATING	Indicates oven heating elements are heating (amber)
5	Oven Door Handle	Secures door in closed position.
6	LEFT CENTER RIGHT	Indicates corresponding range top element is ON (amber).
7	Oven Vent	Open/Close oven vent.

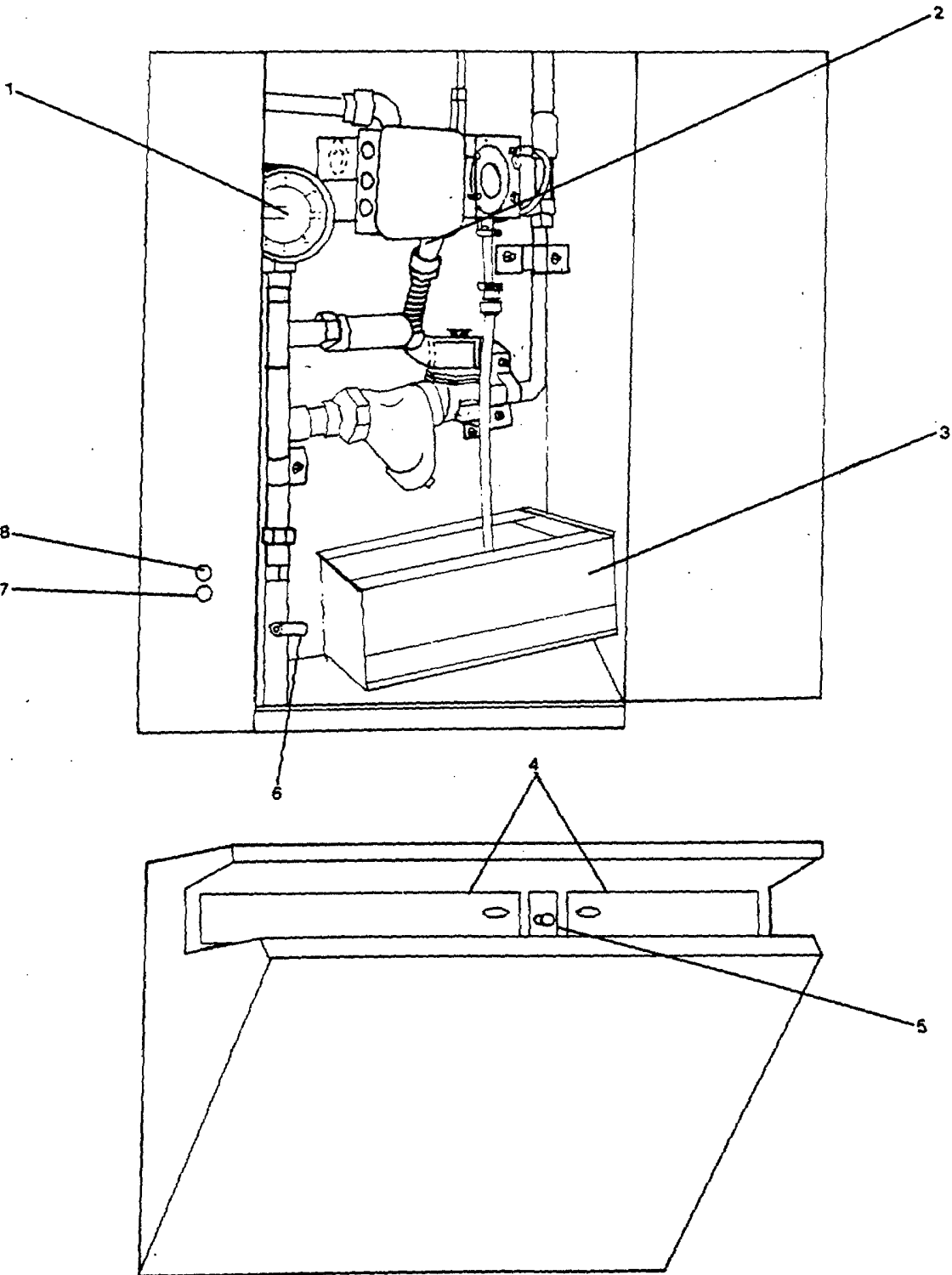

FIGURE 2-70. Gaylord Hood Controls (Sheet 1 of 2).

**Table 2-1. Description of Operator's Controls and Indicators - CONT**

Key	Control or Indicator	Function
Gaylord Hood Controls (FIGURE 2-70)		
1	Pressure Gauge	Gauge provides system pressure reading.
2	Switch	Momentary switch used to test pump.
3	Soap Container	Soap supply for hood system
4	Access Doors	Provides means to visually inspect internal components of hood.
5	Vent Control	Controls exhaust damper.
6	Shut-off valve	Controls hood plumbing system.
7	Start Pushbutton	Pushbutton starts exhaust ventilator.
8	Stop Pushbutton	Pushbutton stops exhaust ventilator
9	Output Valve	Controls pump fluid output to Gaylord Vent System.
10	Switch	ON-OFF control for booster heater.
11	Input Valve	Controls fluid input to pump.

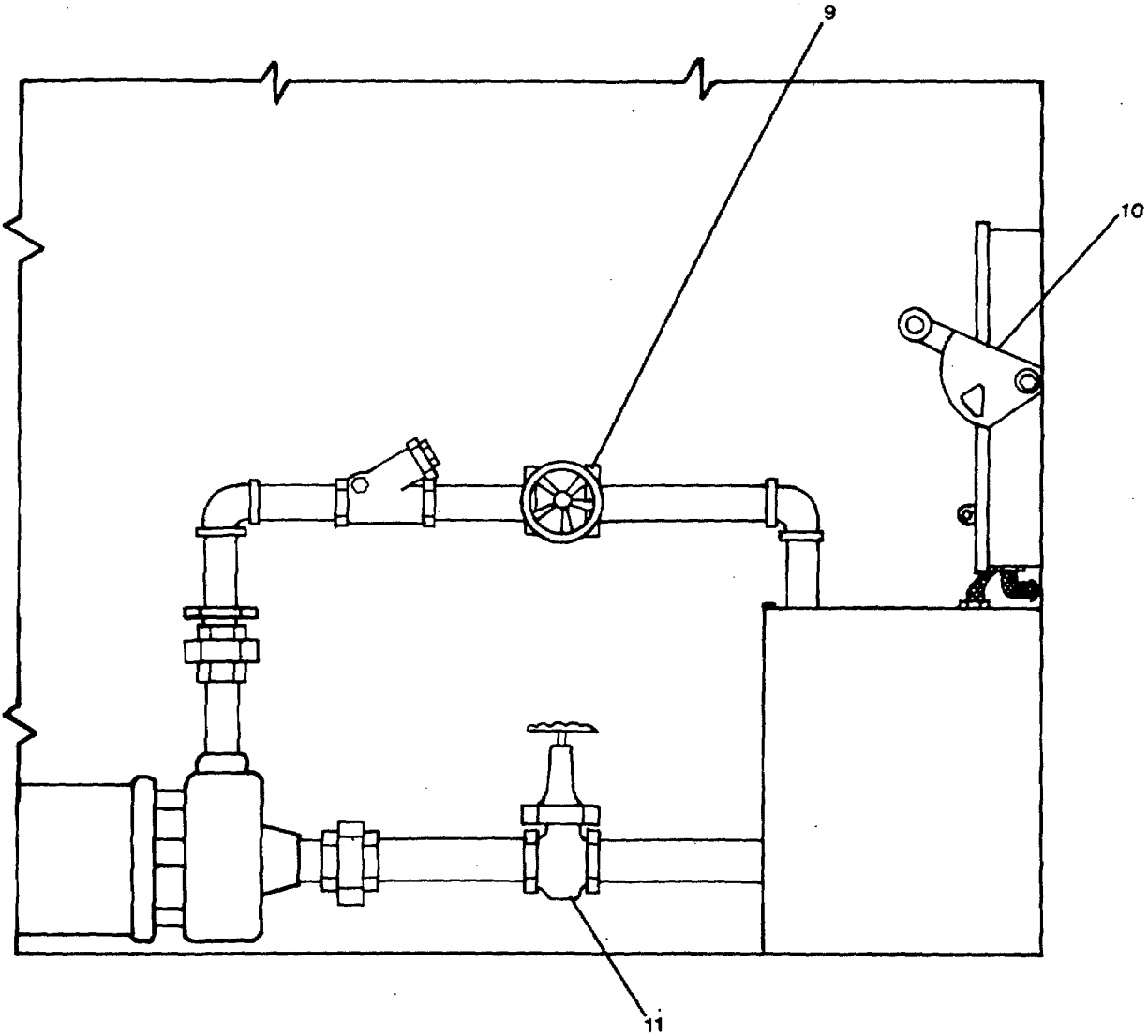

FIGURE 2-70. Gaylord Hood Controls (Sheet 2 of 2).



**Table 2-1. Description of Operator's Controls and Indicators - CONT**

Key	Control or Indicator	Function
Meat Slicer (FIGURE 2-71)		
1	Meat Grip	Provides aid for holding odd shapes or short end pieces.
2	Carriage	Allows back and forth movement with right hand while left hand is free to receive slices as they come from the knife.
3	Slice Adjusting, Dial	Adjusts thickness of slices cut.
4	On-Off Switch	Controls slicer operation.
5	Sharpener Slot	Provides a mounting position for slicer knife sharpener.
6	Slicer Knife	Cuts product as it is fed through on the carriage.

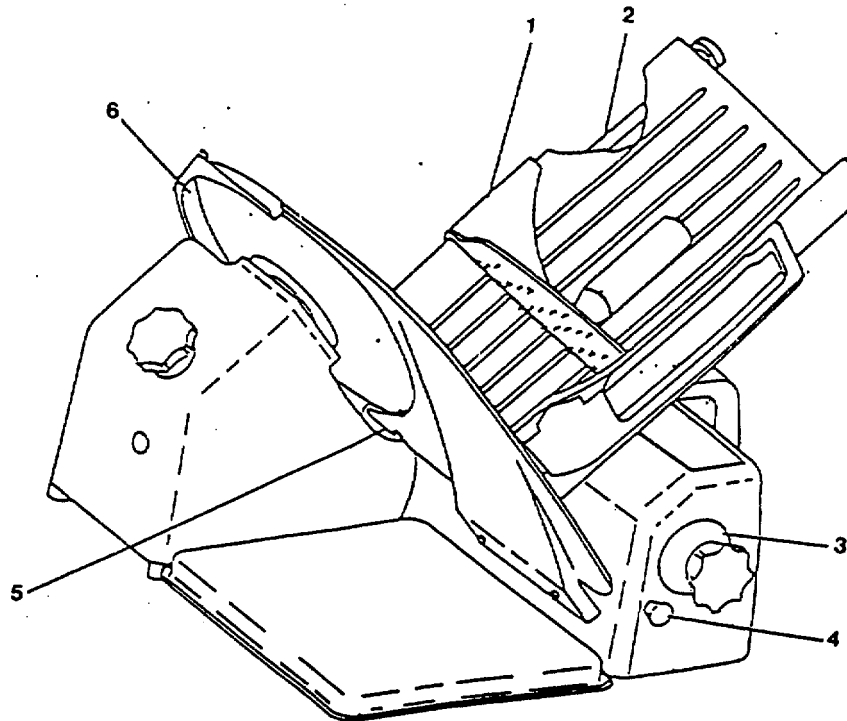

FIGURE 2-71. Meat Slicer.

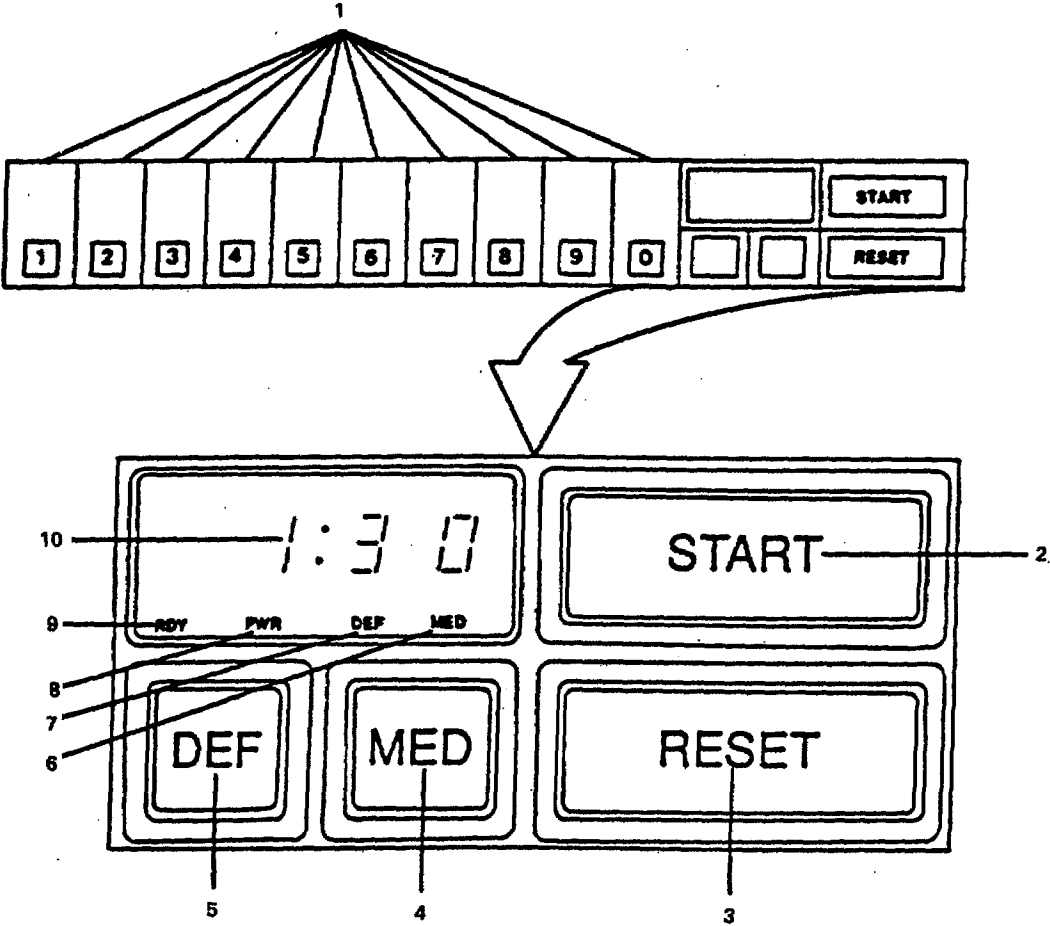

FIGURE 2-72. Microwave Oven Panel.

**Table 2-1. Description of Operator's Controls and Indicators - CONT**

Key	Control or Indicator	Function
Microwave Oven Panel (FIGURE 2-72)		
1	Time Pads	Selects oven operating time.
2	START	Starts oven.
3	RESET	Clears time and power level entries for new instructions.
4	MED	Sets oven to medium power mode.
5	DEF	Sets oven to defrost mode.
6	MED	Indicates oven has been set on medium power mode.
7	DEF	Indicates oven has been set on defrost power mode.
8	PWR	Indicates oven is activated and time countdown has started.
9	RDY	Indicates oven is ready for start after time has been set.
10	Digital Timer Display	Indicates time set by time pads.

**Table 2-1. Description of Operator's Controls and Indicators - CONT**

Key	Control or Indicator	Function
Electric Mixer (FIGURE 2-73)		
1	Auxiliary Drive Socket	Provides drive slot for auxiliary cutters.
2	Thumb Screw	Locks auxiliary drive shaft in drive socket.
3	Speed Change Lever	Adjusts mixer speeds as required.
4	On-Off Power Switch	Controls electrical power to electric mixer.
5	Bowl Lift Handle	Adjusts depth of bowl.
6	Bowl Support	Provides lock and support of mixing bowl.
7	Attachment Spindle	Provides means of attaching blades and beaters.
8	Beater Shaft	Provides rotating drive force.

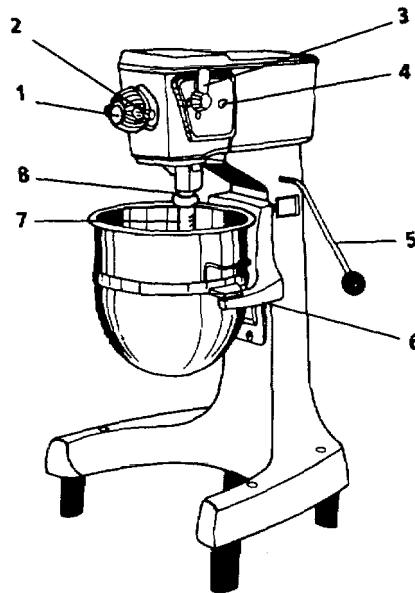

FIGURE 2-73. Electric Mixer.

**Table 2-1. Description of Operator's Controls and Indicators-CONT**

Key	Control or Indicator	Function
Milk Dispenser (FIGURE 2-74)		
1	Milk Dispenser	Hold bulk milk.
2	Thermometer	Gives a continuous reading of temperature in dispenser.
3	Dispensing Valve	Movement of dispensing valve will discharge milk from the holding container.
4	Key Lock	Key lock to secure dispenser door.
5	Latch	Secures door in closed position.

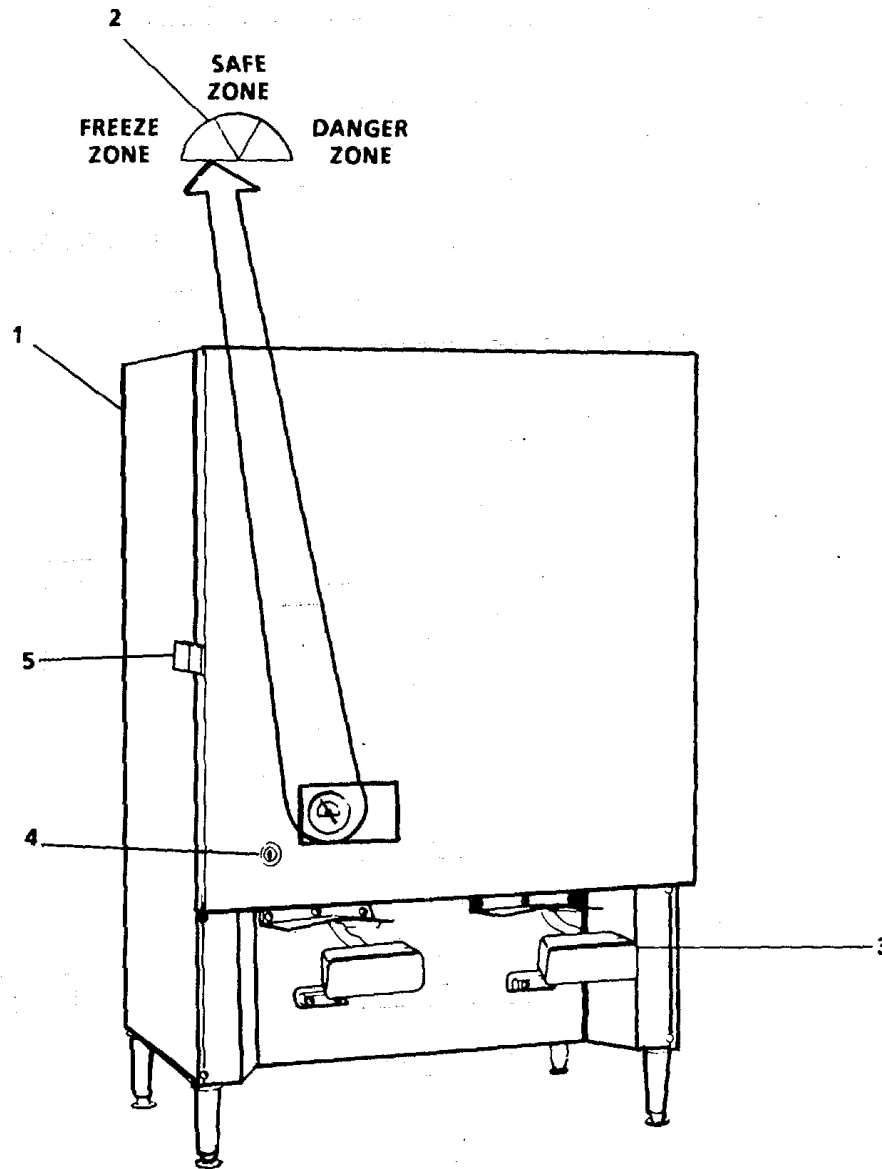

FIGURE 2-74. Milk Dispenser.

**Table 2-1. Description of Operator's Controls and Indicators-CONT**

Key	Control or Indicator	Function
Post-Mix Dispenser (FIGURE 2-75)		
1	Cover with Water Lever	Installed in along side number 3 position, dispenses only carbonated water.
2	Dispensing Valves	Dispenses five different product flavors.
3	Carbonated Water Pump Switch	Located under top cover, controls carbonated water pump operation.
4	Dispensing Valves Keyed Lockout Switch	Provides control of electric dispensing valves.
5	Unit Power Switch	Must be in ON position before unit will operate.
6	Dispensing Lever	Releases drink.

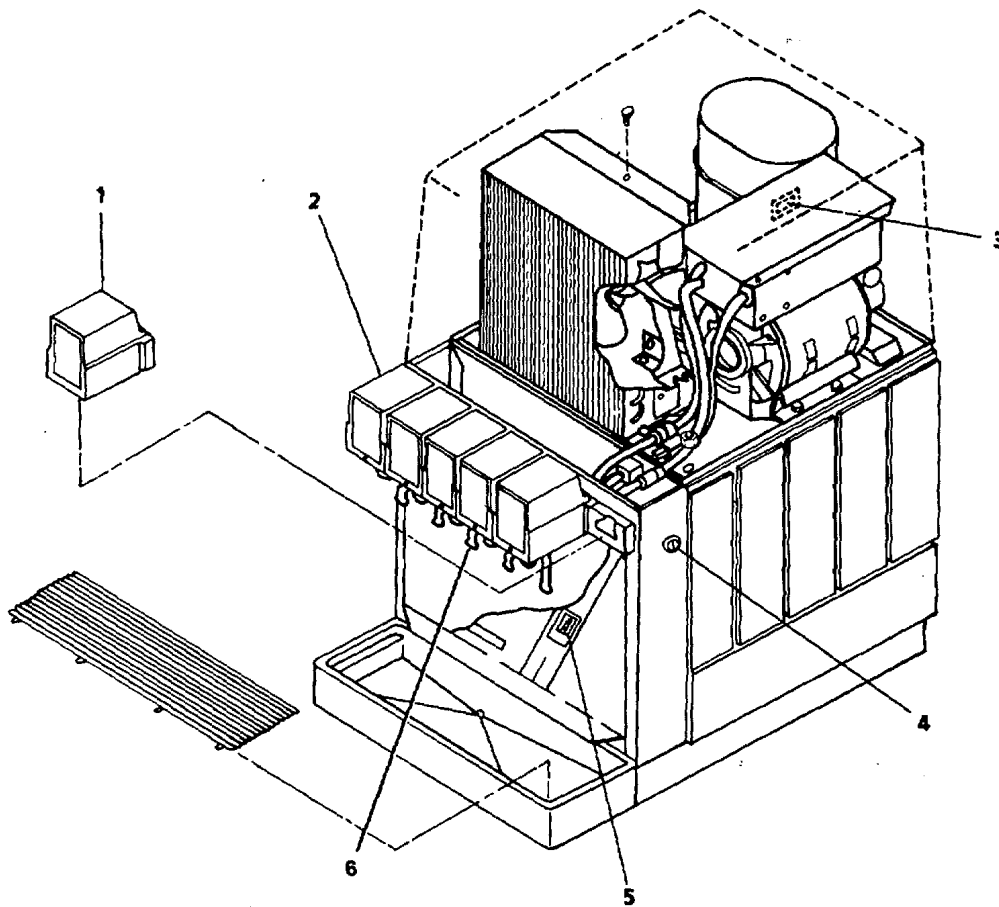

FIGURE 2-75. Post-Mix Dispenser.

**Table 2-1. Description of Operator's Controls and Indicators-CONT**

Key	Control or Indicator	Function
Marine Coffee Maker OT-20 (FIGURE 2-76)		
1	ON-OFF	Controls heating element of top warmer.
2	Indicator Light	Indicates top warmer is on (red).
3	START	Deflecting START switch will start a brew cycle and allow water to flow into tank.
4	Indicator Light	Indicates that power is on for brewer and that bottom warmer is on (red).
5	ON-OFF	Turns power on to brewer and bottom warmer.
6	Coffee Pot Guard	Prevents coffee pots from sliding off coffee maker during inclement weather.
7	Coffee Pot	Container for brewed coffee.
8	Funnel	Contains the filter and coffee grounds.

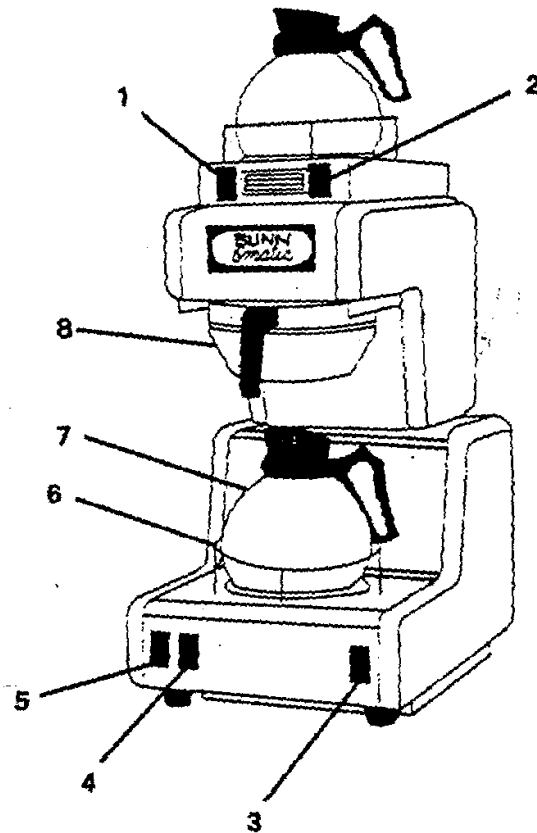

FIGURE 2-76. Marine Coffee Maker OT-20.

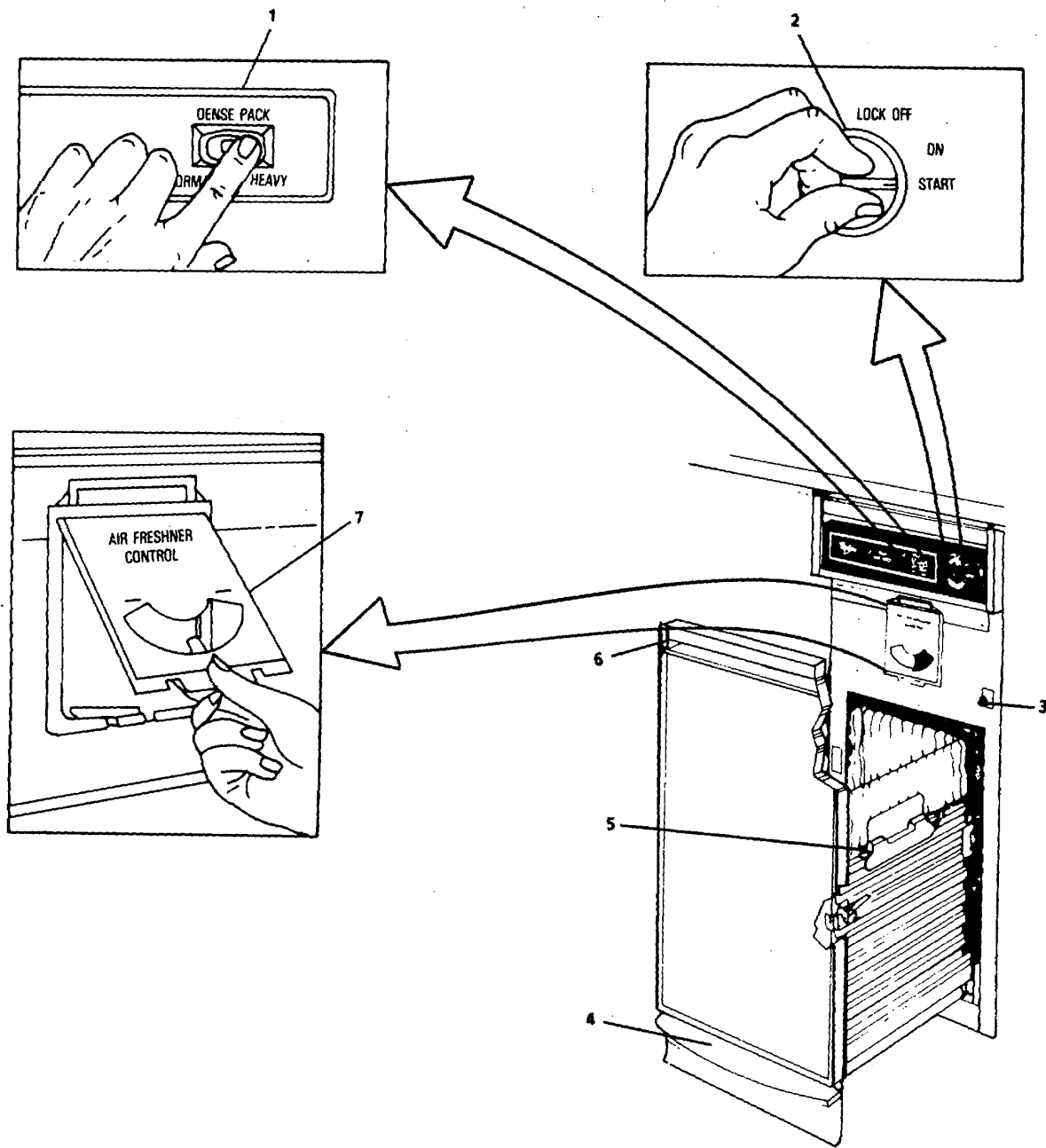

FIGURE 2-77. Trash Compactor.



**Table 2-1. Description of Operator's Controls and Indicators-CONT**

Key	Control or Indicator	Function
Trash Compactor (FIGURE 2-77)		
1	DENSE PACK	Allows use of few bags by putting constant pressure on trash to keep it from springing back.
2	LOCK/OFF-ON-START	Provides control of trash compactor cycle activation.
3	Drawer Monitor	Prevents trash compactor operation with drawer open.
4	Touch-Toe Bar	When depressed, opens drawer.
5	Bag Carrier Handle	Holds rope securing bag in place.
6	Drawer Handle	Lift and pull handle to open drawer.
7	AIR FRESHENER CONTROL	Dial set at normal, maximum or minimum as needed.

**Table 2-1. Description of Operator's Controls and Indicators-CONT**

Key	Control or Indicator	Function
Freezer Model F30-2M-ADS (FIGURE 2-78)		
1	Thermometer	Indicates temperature inside freezer.
2	Handle Assembly	Used to open door; also contains a key lock.

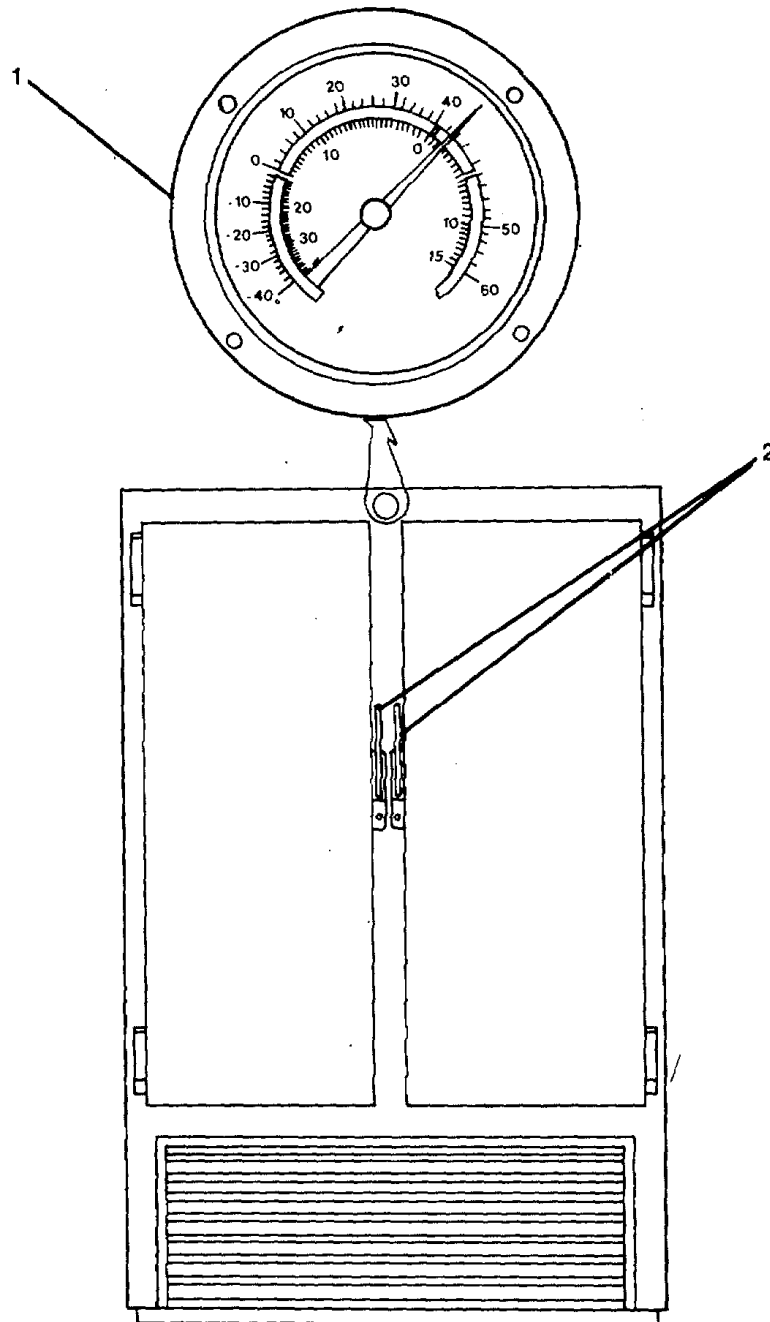

FIGURE 2-78. Freezer Model F30-2M-ADS.

Table 2-1. Description of Operator's Controls and Indicators-CONT

Key	Control or Indicator	Function
Freezer Model F20-2M-ADS (FIGURE 2-79)		
1	Thermometer	Indicates temperature inside freezer.
2	Handle Assembly	Used to open door; also contains a key lock.

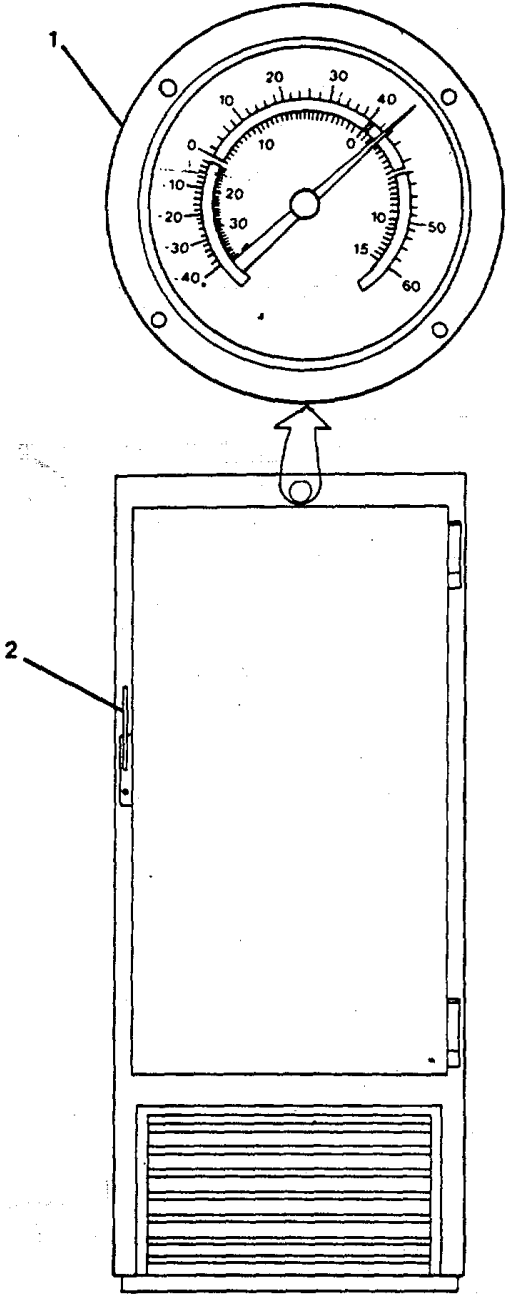

FIGURE 2-79. Freezer Model F20-2M-ADS.

**Table 2-1. Description of Operator's Controls and Indicators-CONT**

Key	Control or Indicator	Function
Refrigerator Model R30-2M-S (FIGURE 2-80)		
1	Thermometer	Indicates temperature inside the refrigerator.
2	Handle Assembly	Used to open door; also contains a key lock.

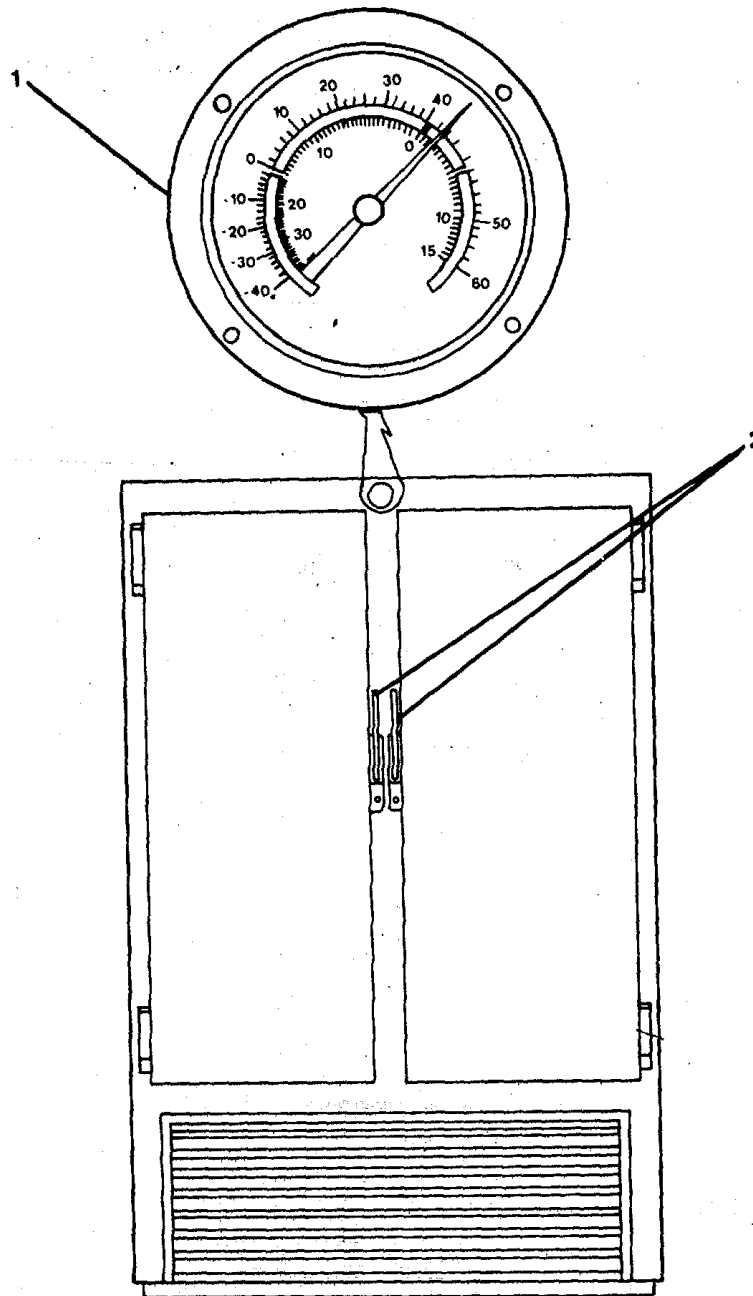

FIGURE 2-80. Refrigerator Model R30-2M-S.

**Table 2-1. Description of Operator's Controls and Indicators-CONT**

Key	Control or Indicator	Function
Refrigerator Model R18-2M-S (FIGURE 2-81)		
1	Thermometer	Indicates temperature inside the refrigerator.
2	Handle Assembly	Used to open door; also contains a key lock.

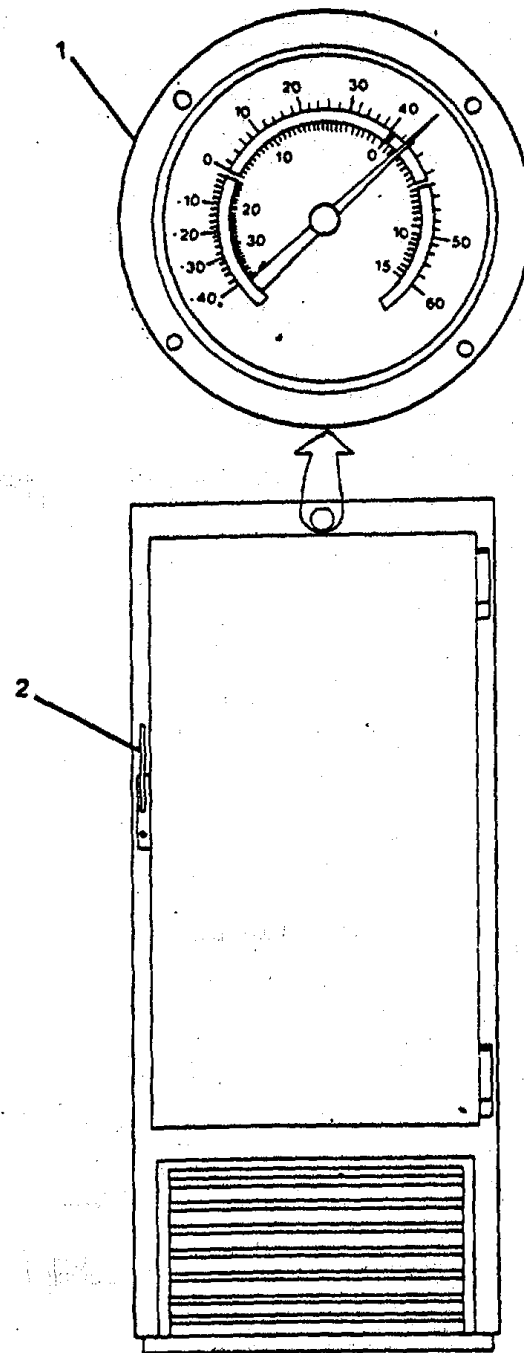
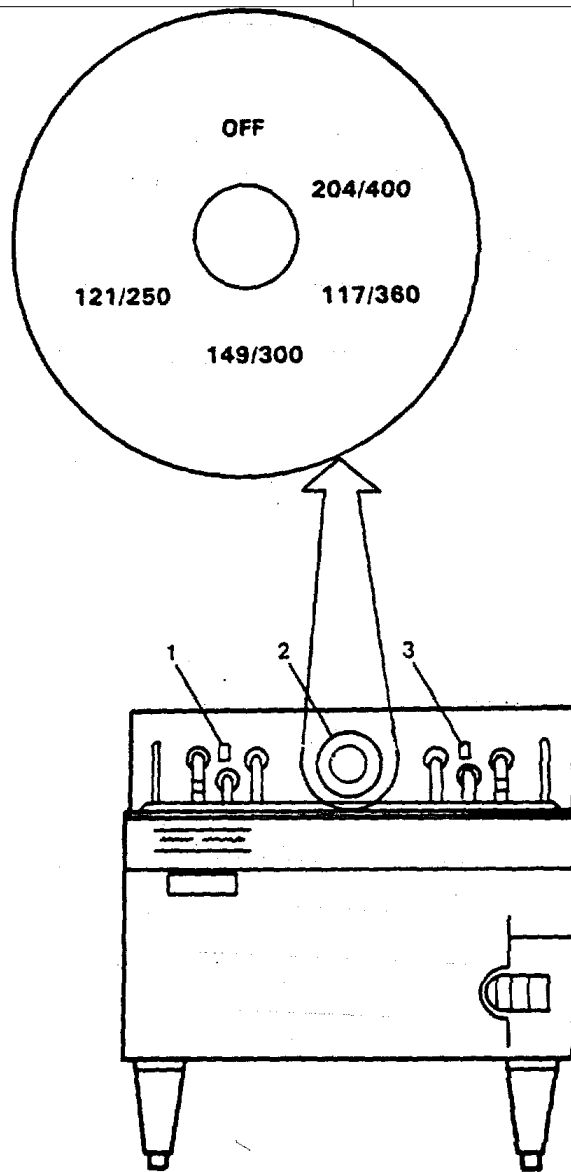

FIGURE 2-81. Refrigerator Model R18-2M-S.

**Table 2-1. Description of Operator's Controls and Indicators-CONT**

Key	Control or Indicator	Function
Fry Kettle (FIGURE 2-82)		
1	Indicator Light	Indicates that temperature control is turned to any heating position and that elements are energized (amber).
2	Thermostat Dial	Automatically maintains fat at selected temperatures from 250°-400°F.
3	Overheat Light	Indicates that electric current to heating elements has been interrupted due to overheating of cooking oil (red).



*FIGURE 2-82. Fry Kettle.*

Table 2-1. Description of Operator's Controls and Indicators-CONT

Key	Control or Indicator	Function
	Ice Maker (FIGURE 2-83)	
1	Handle	Used to open door for access to ice storage compartment.

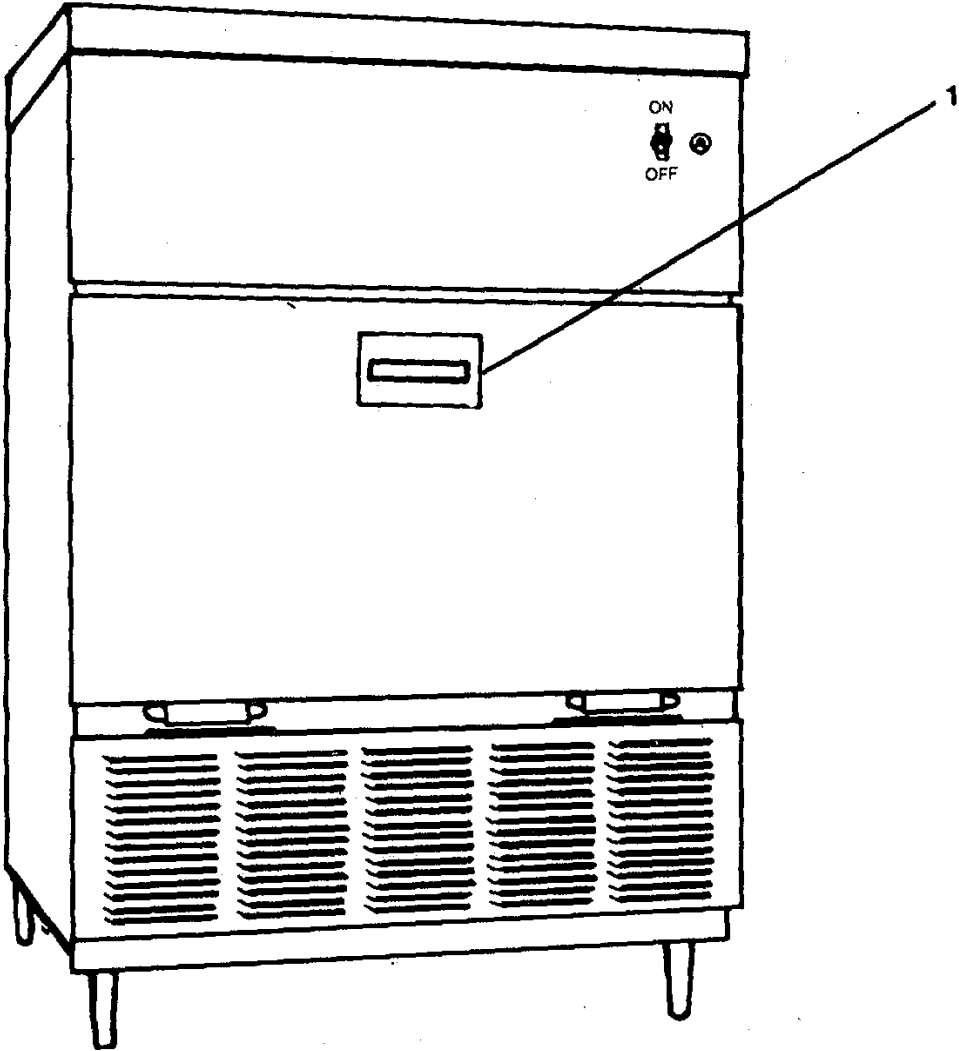

FIGURE 2-83. Ice Maker.

Table 2-1. Description of Operator's Controls and Indicators-CONT

Key	Control or Indicator	Function
Type I Motor Switch (FIGURE 2-84)		
1	START	Pushbutton to start motor it controls.
2	STOP	Pushbutton to stop motor it controls.
3	LOCK	Slide lock to lock motor in the stopped condition.

**NOTE**  
This type motor controllers is used throughout the vessel to control various motor driven equipment.

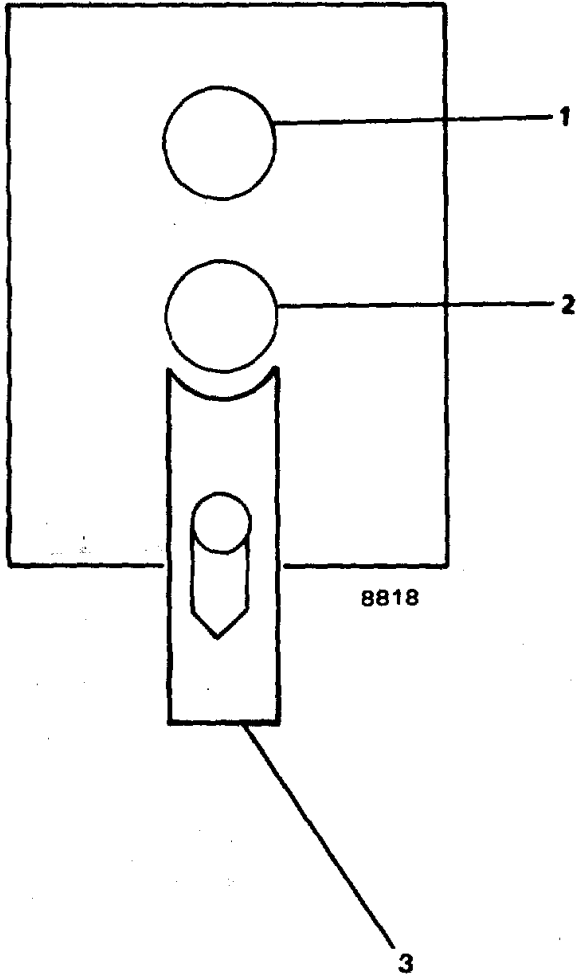

FIGURE 2-84. Type I Motor Switch.



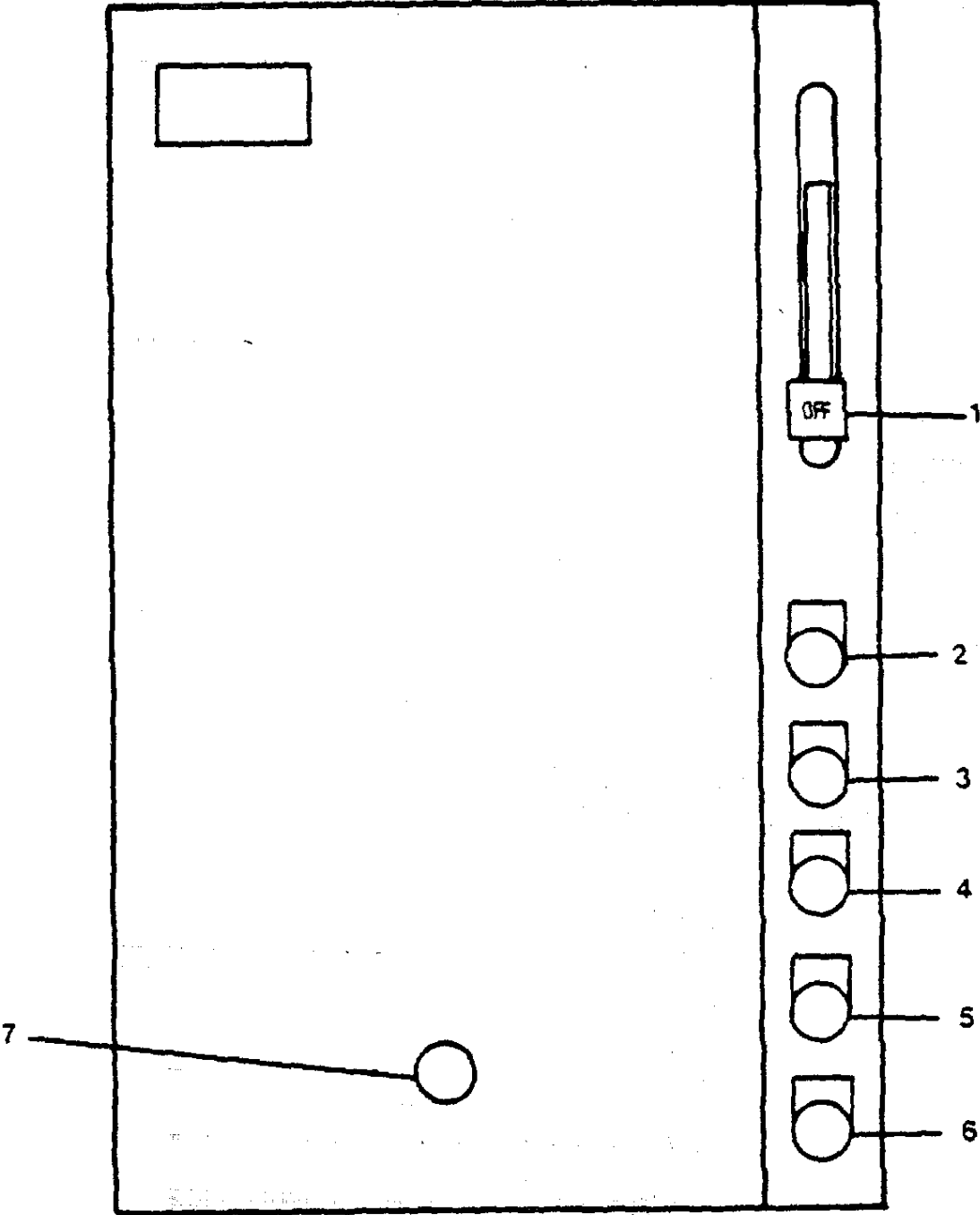

FIGURE 2-85. Type II Motor Controller.

**Table 2-1. Description of Operator's Controls and Indicators-CONT**

Key	Control or Indicator	Function
Type II Motor Controller (FIGURE 2-85)		
1	ON-OFF	Provides ON-OFF control with 15-ampere circuit protection. Switch may be locked in OFF
2	START	Pushbutton starts motor it controls.
3	STOP	Pushbutton stops motor it controls.
4	MOTOR RUN	Indicates that motor it controls is operating (green).
5	MOTOR STOP	Indicates that motor it controls is stopped (white).
6	EMERGENCY RUN	Pushbutton operates motor it controls for time pushbutton is pressed.
7	RESET	Resets motor it controls.
<b>NOTE</b>		
This type motor controller is used throughout the vessel to control various motor driven equipment.		

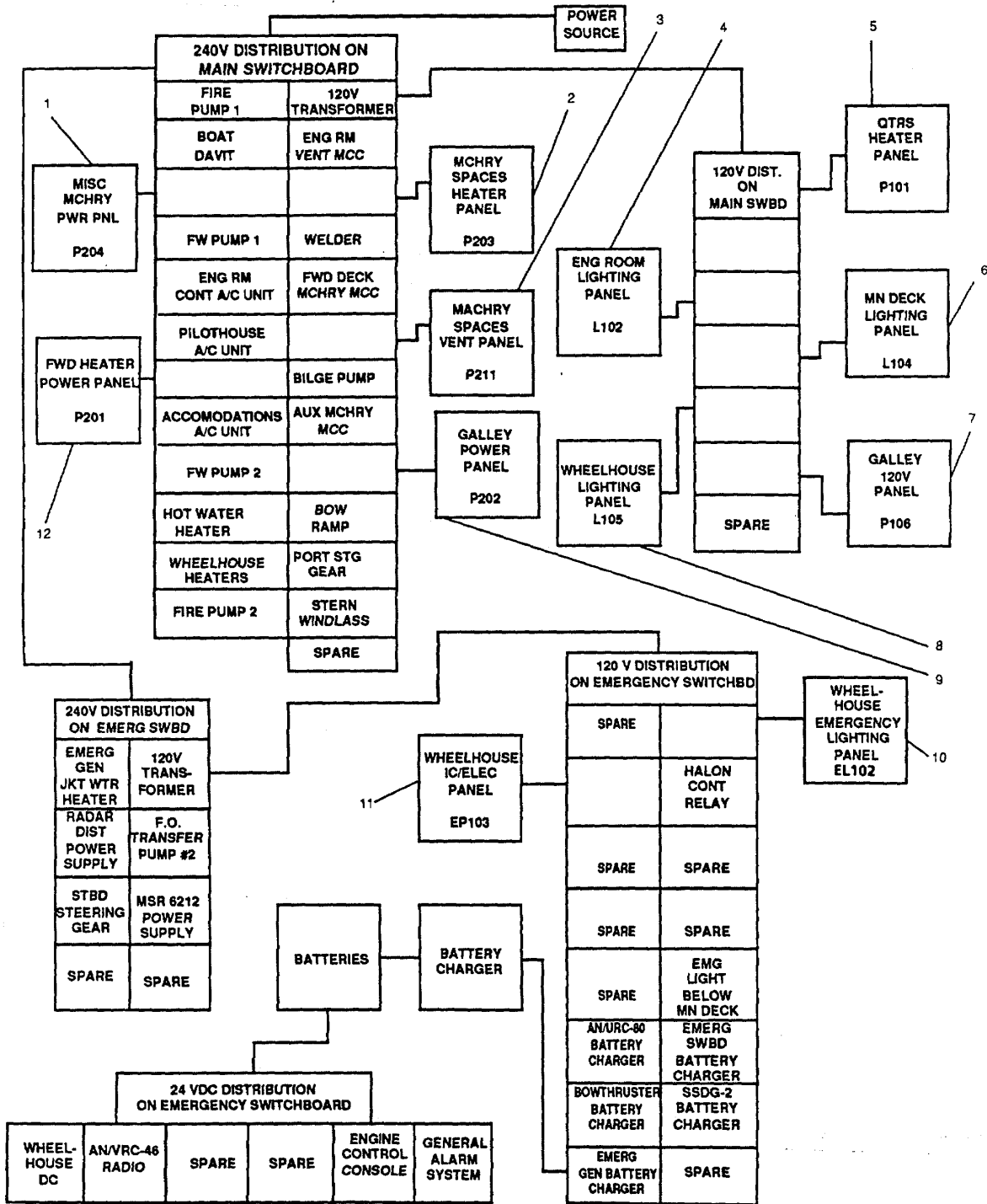
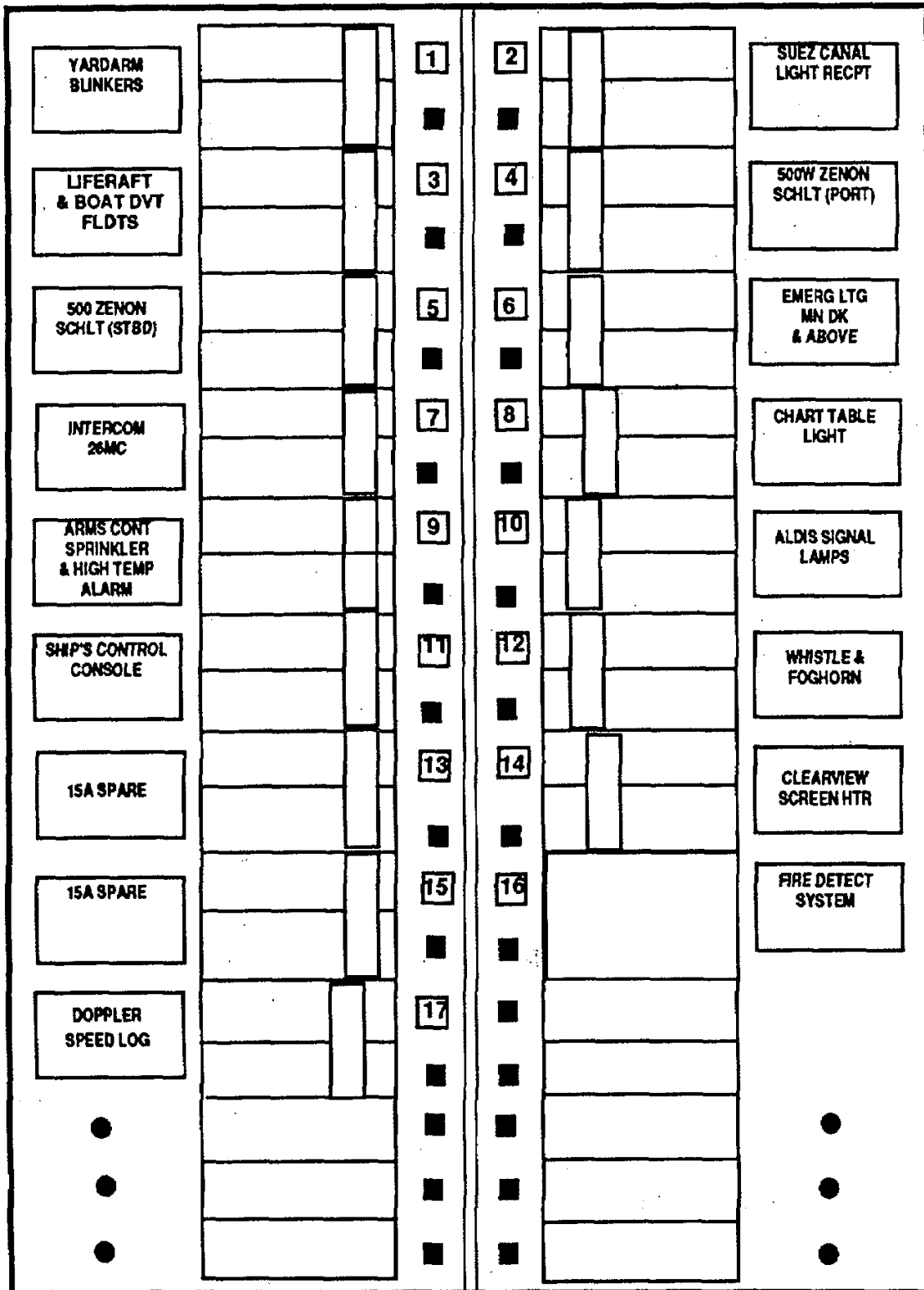

FIGURE 2-86. Power and Lighting Distribution Panels (Sheet 1 of 13).

**Table 2-1. Description of Operator's Controls and Indicators-CONT**

Key	Control or Indicator	Function
Power and Lighting Distribution Panels (FIGURE 2-86)		
1	MISC MCHRY PWR PNL P204	Provides protection for and control of circuits shown on Sheet 12.
2	MCHRY SPACES HEATER PANEL P203	Provides protection for and control of panel and circuits shown on Sheet 11.
3	MCHRY SPACES VENT PANEL P211	Provides protection for and control of panel and circuits shown on Sheet 13.
4	ENG ROOM LIGHTING PANEL L102	Provides protection for and control of panel and circuit shown on Sheet 4.
5	QTRS HEATER PANEL P101	Provides protection for and control of panel and circuits shown on Sheet 7.
6	MN DECK LIGHTING PANEL L104	Provides protection for and control of panel and circuits shown on Sheet 5.
7	GALLEY 120V PANEL P106	Provides protection for and control of panel and circuit shown on Sheet 8.
8	WHEELHOUSE LIGHTING PANEL L105	Provides protection for and control of circuits shown on Sheet 6.
9	GALLEY POWER PANEL P202	Provides protection for and control of panel circuits shown on Sheet 10.
10	WHEELHOUSE EMERGENCY LIGHTING PANEL EL102	Provides protection for and control of panel and circuits shown on Sheet 2.
11	WHEELHOUSE IC/ELEC PANEL EP103	Provides protection for and control of panel and circuit shown on Sheet 3.
12	FWD HEATER POWER PANEL P201	Provides protection for and control of panel and circuits shown on Sheet 9.



EL102

FIGURE 2-86. Power and Lighting Distribution Panels (sheet 2 of 13).

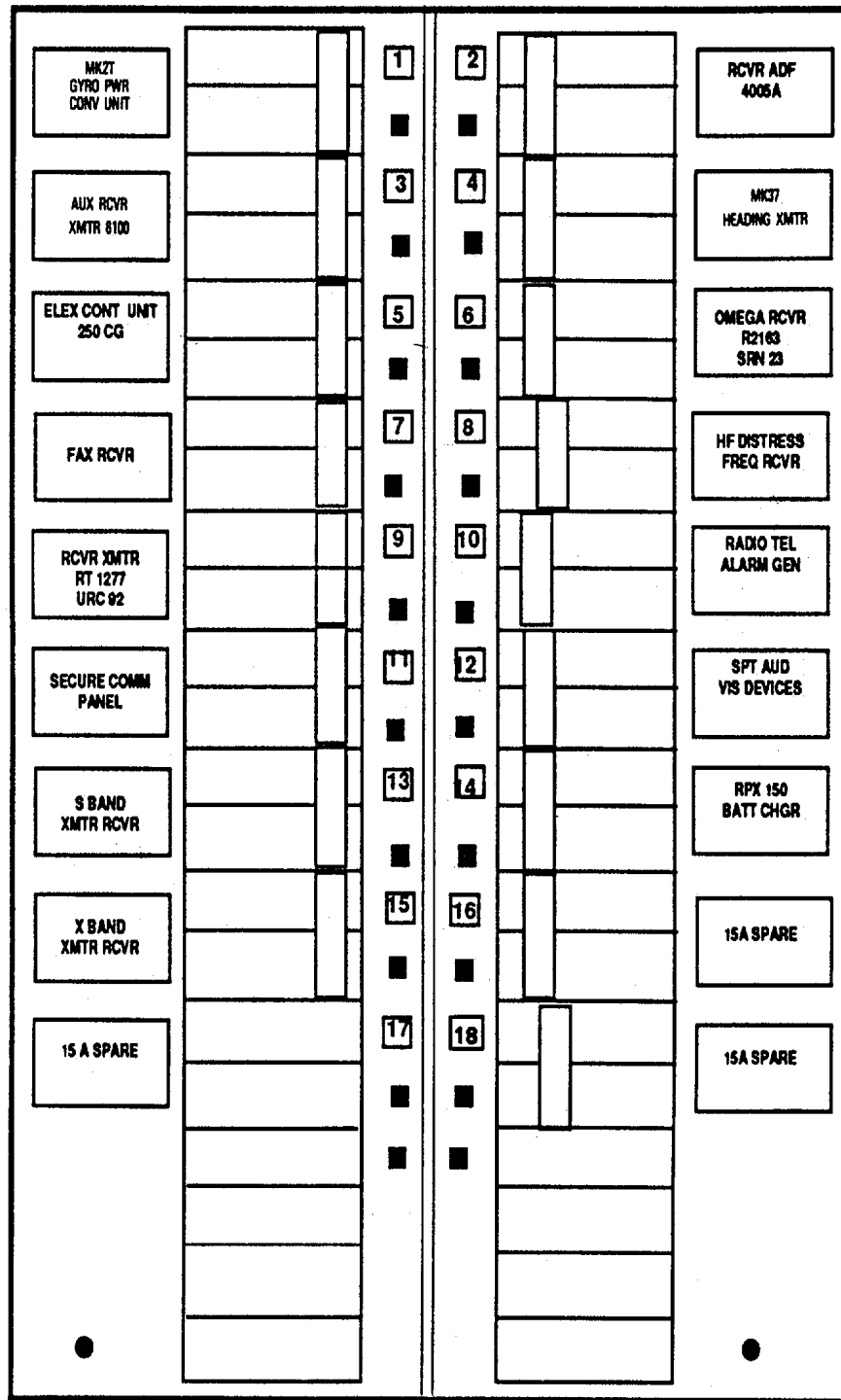

EL103

FIGURE 2-86. Power and Lighting Distribution Panels (sheet 3 of 13).

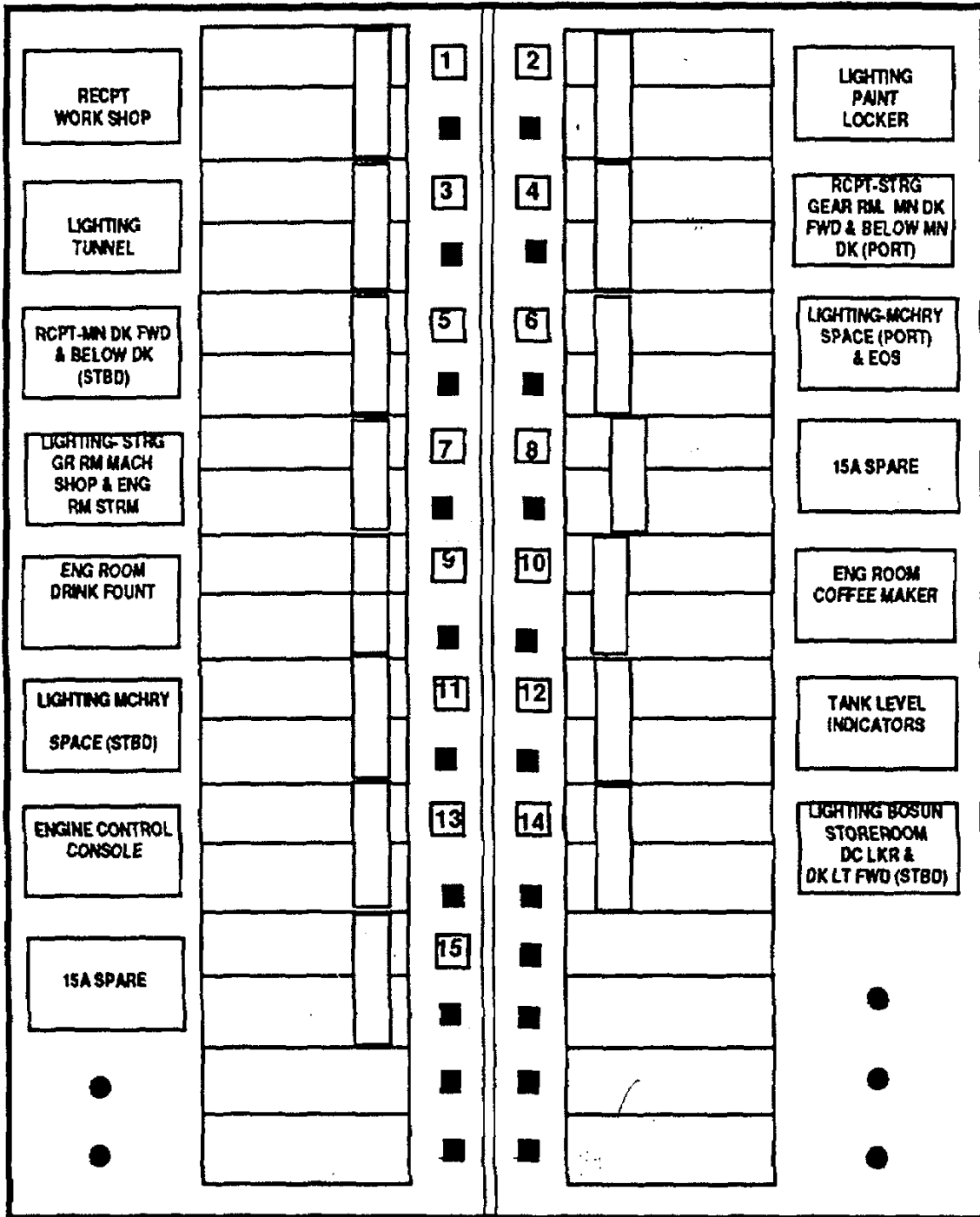

L102

FIGURE 2-86. Power and Lighting Distribution Panels (sheet 4 of 13).

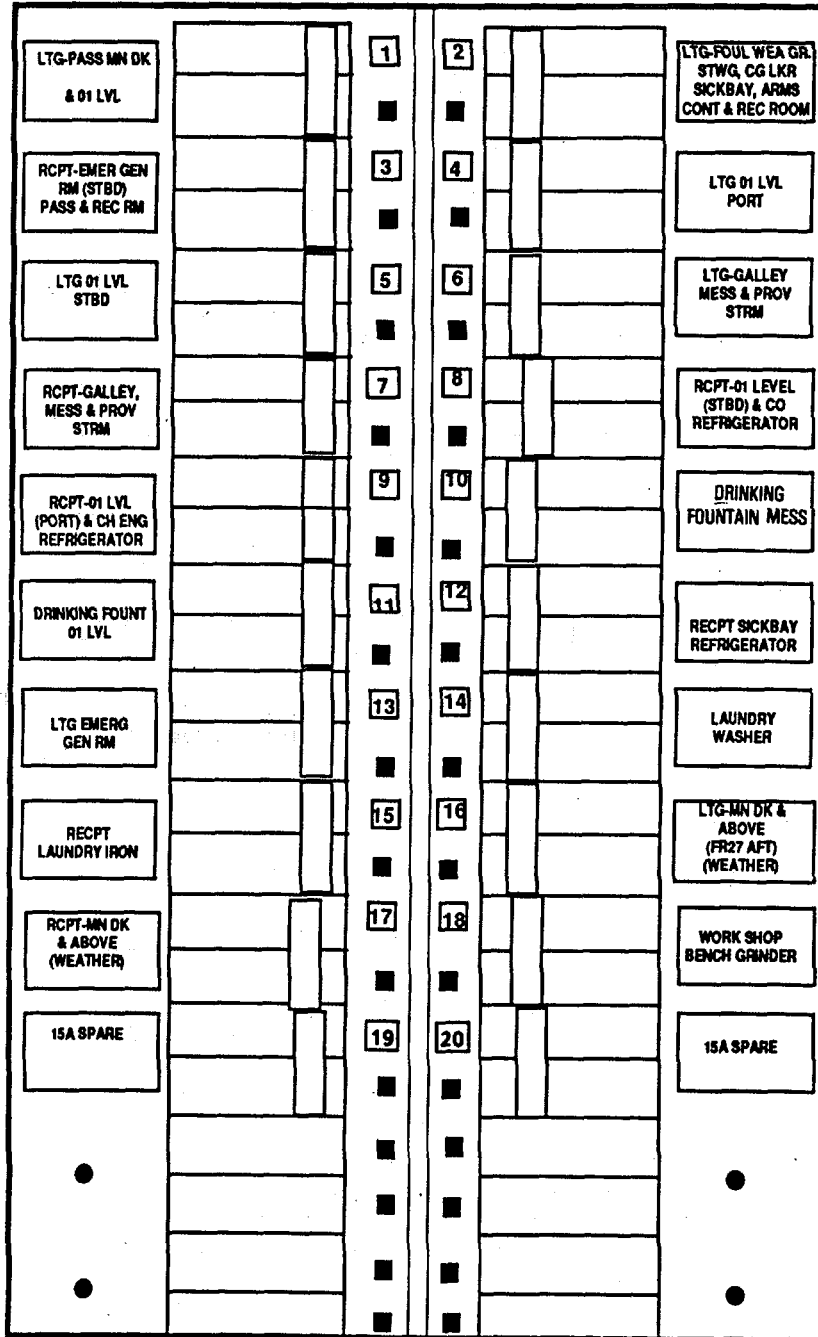

L104

FIGURE 2-86. Power and Lighting Distribution Panels (Sheet 5 of 13).



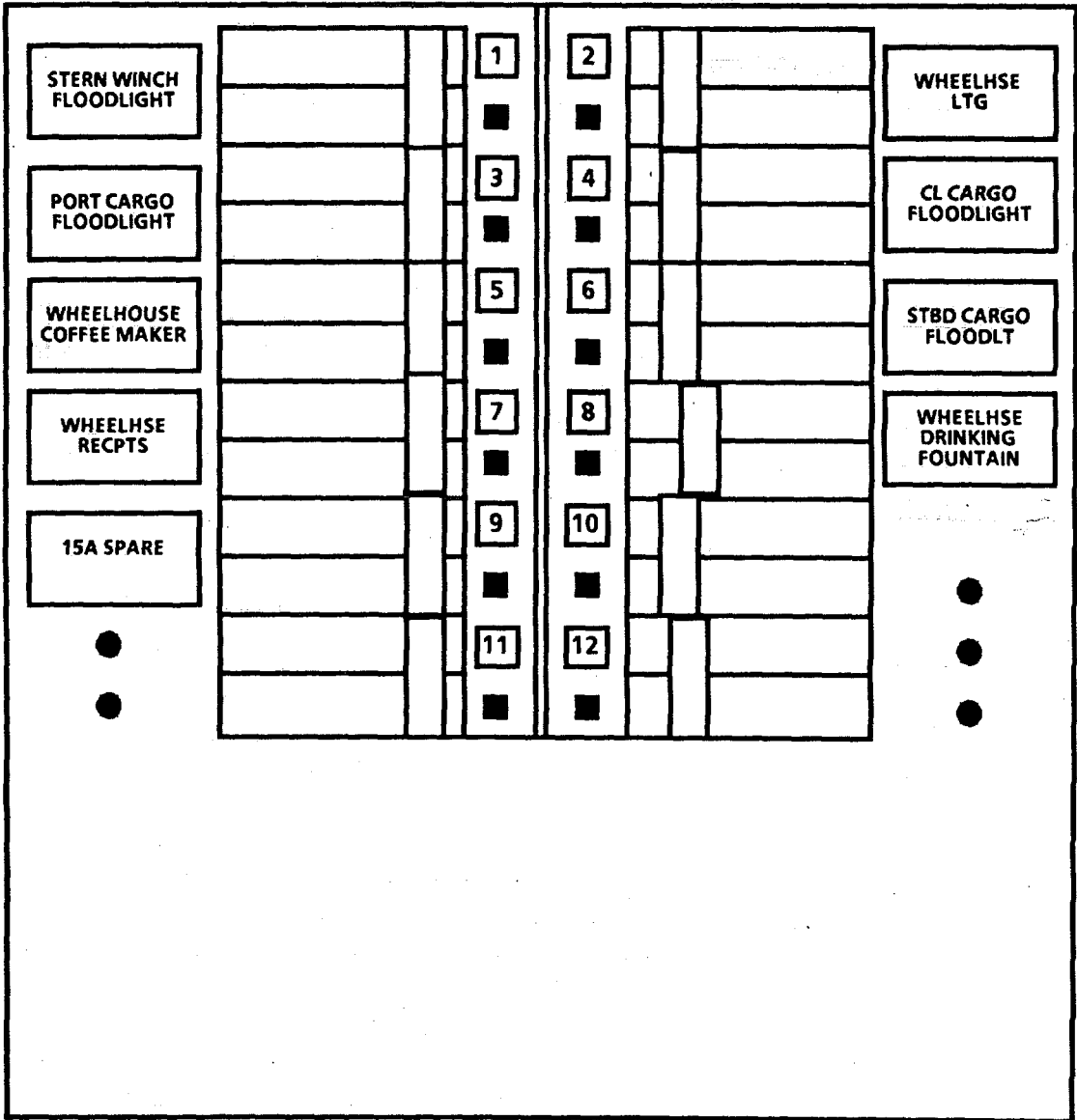

L105

FIGURE 2-86. Power and Lighting Distribution Panels (Sheet 6 of 13).

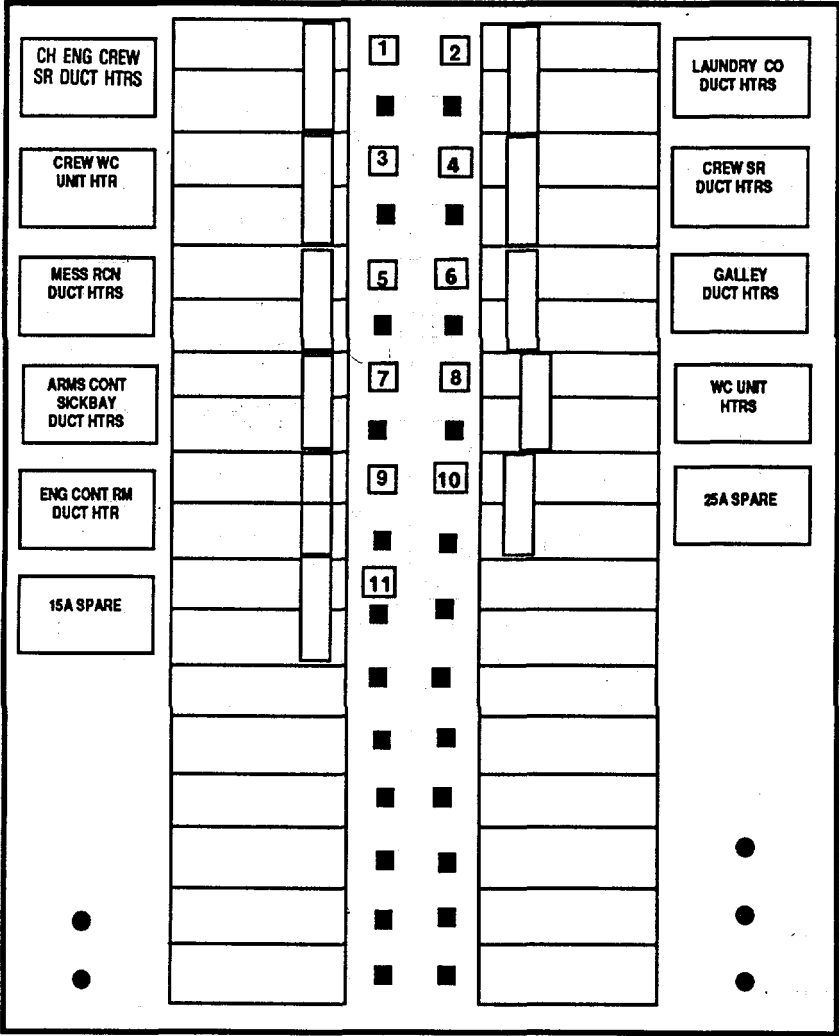

P101

FIGURE 2-86. Power and Lighting Distribution Panels (Sheet 7 of 13).

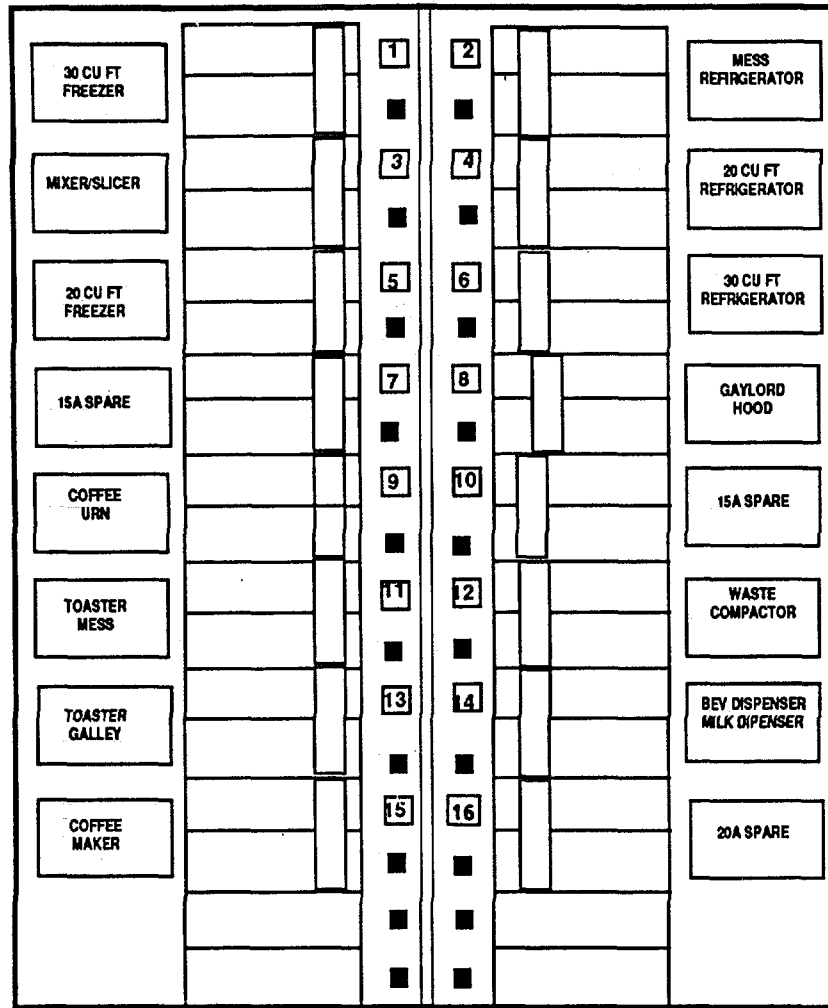

P106

FIGURE 2-86. Power and Lighting Distribution Panels (Sheet 8 of 13).

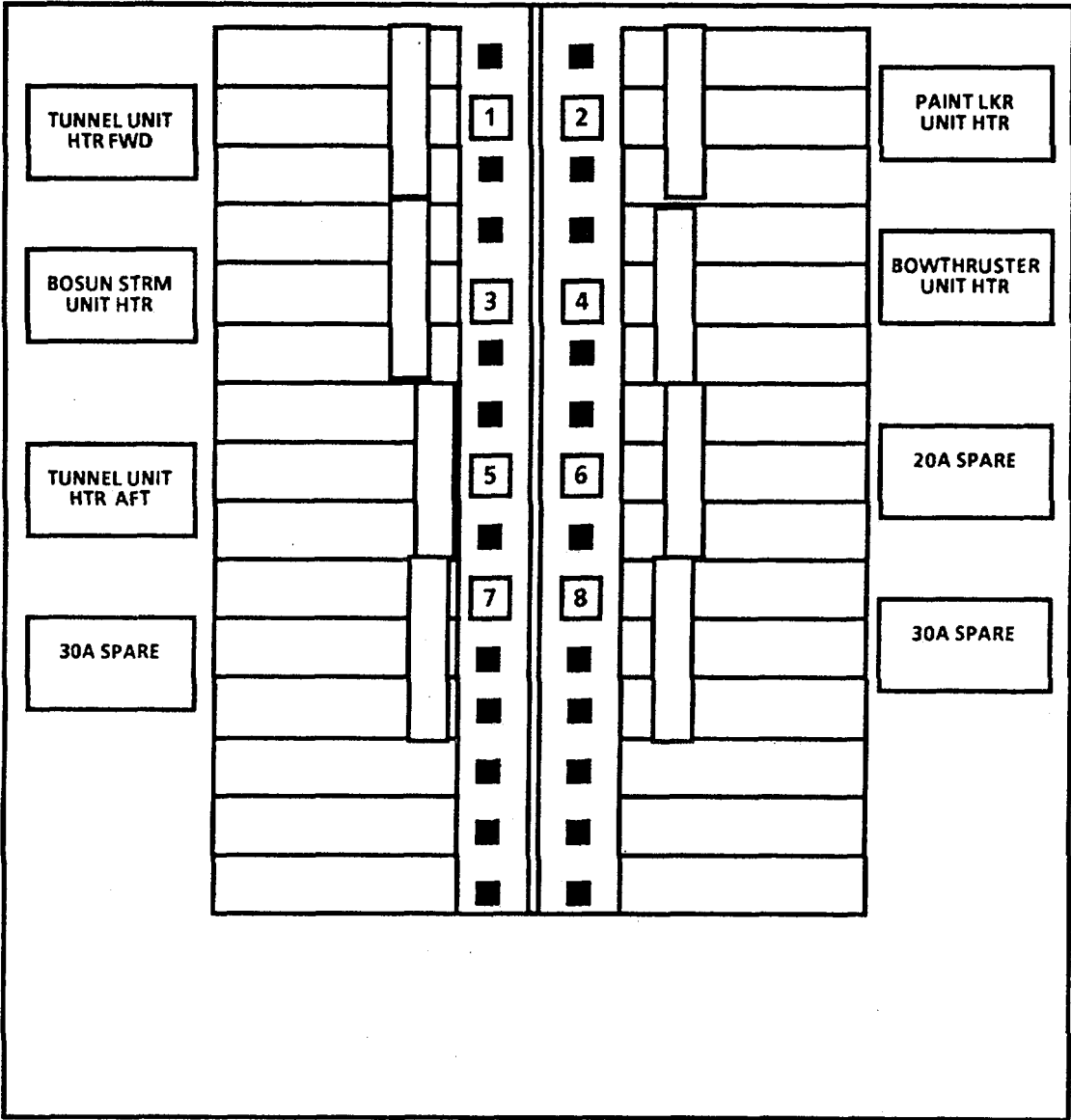

P201

FIGURE 2-86. Power and Lighting Distribution Panels (Sheet 9 of 13).

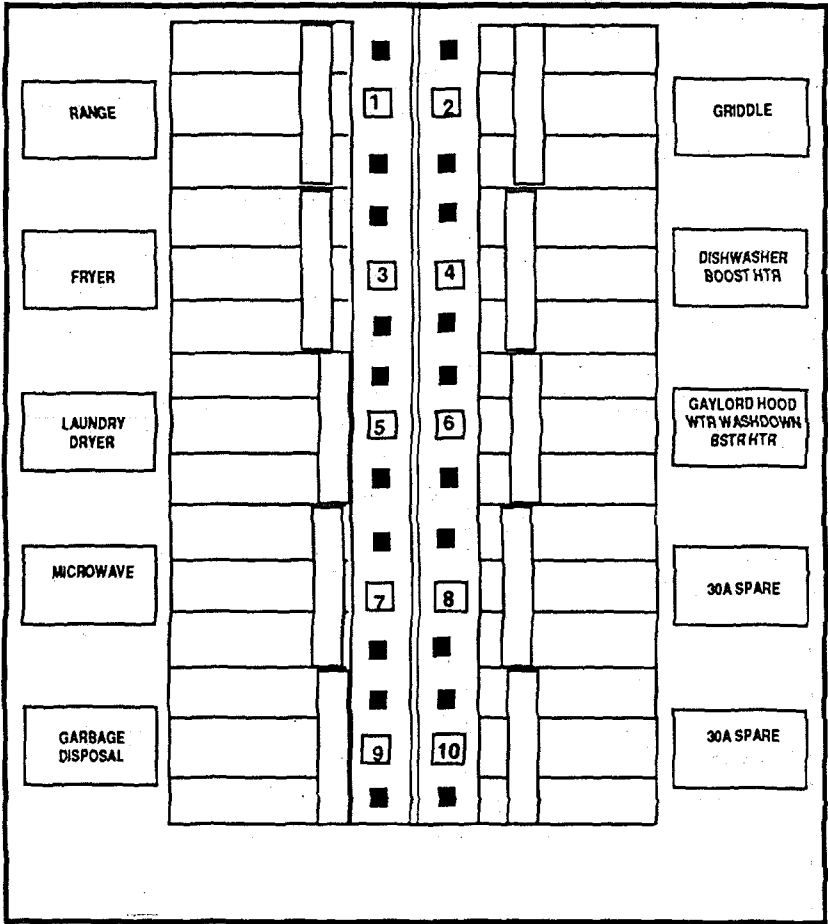

P202

FIGURE 2-86. Power and Lighting Distribution Panels (Sheet 10 of 13).

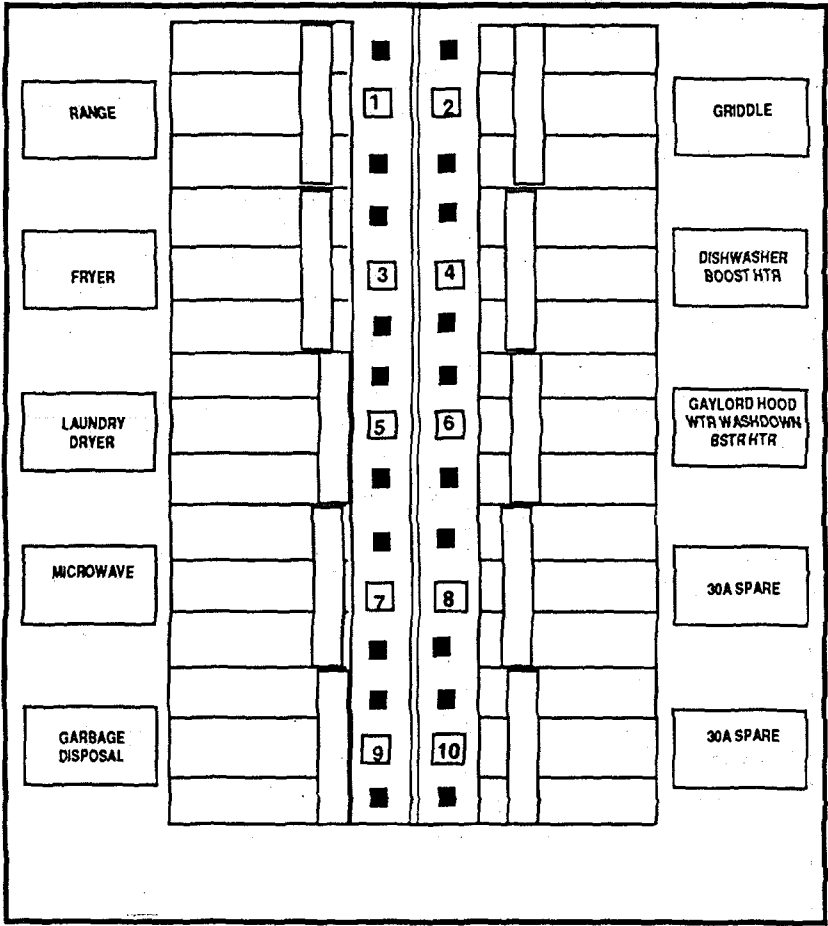

P202

FIGURE 2-86. Power and Lighting Distribution Panels (Sheet 11 of 13).

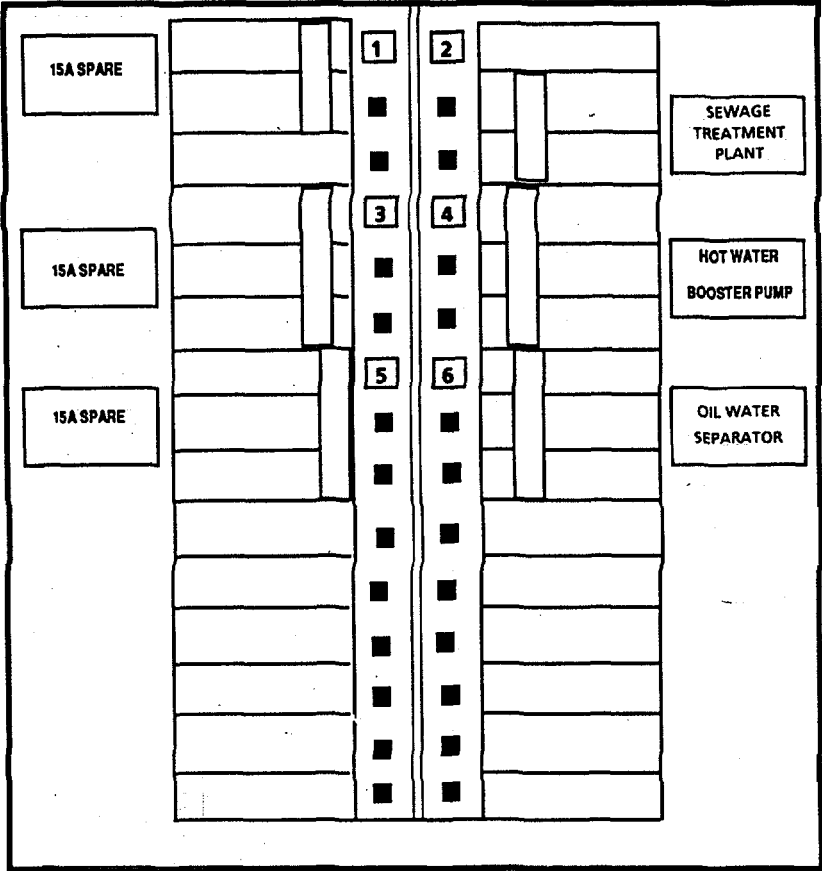

P204

FIGURE 2-86. Power and Lighting Distribution Panels (Sheet 12 of 13).

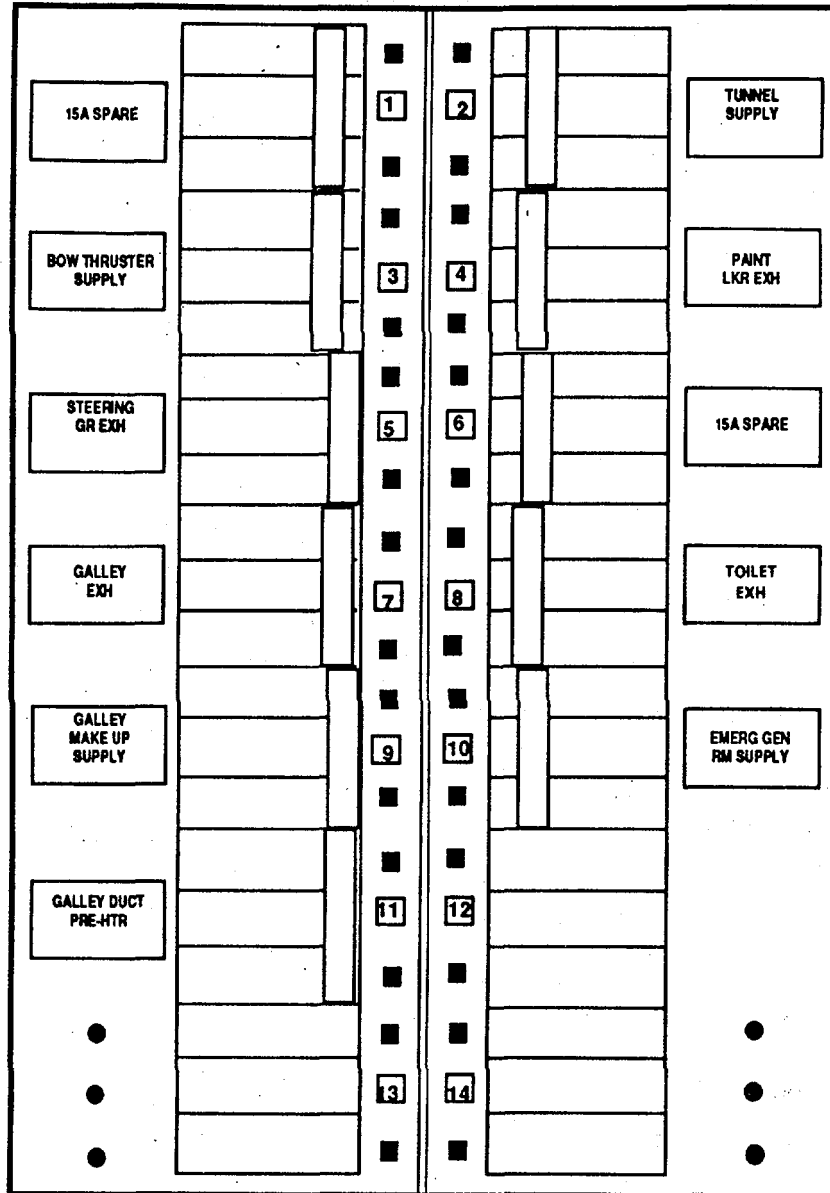

P211

FIGURE 2-86. Power and Lighting Distribution Panels (Sheet 13 of 13).



**Section II. PREVENTIVE MAINTENANCE CHECKS AND SERVICE (PMCS)**

**2-2. PMCS Introductory Material.**

<u>Compartment/Item To Be Inspected</u>	<u>Item No.</u>
General	
Craft Cleanliness.....	1
Life Lines and Stanchions.....	2
Life Jacket.....	3
Life Ring.....	4
Fire Pull Box.....	5
Fire Station and Foam Station.....	6
Portable CO2 Fire Extinguisher.....	7
Doors, Hatches, Covers, and Scuttles.....	8
Intercom.....	9
Sound Powered Telephone.....	10
Power Distribution System.....	11
Space Heaters.....	12
Piping.....	13
Pilothouse Top	
Mast and Yardarm.....	14
Searchlight (Port).....	15
Magnetic Compass.....	16
Gyro Repeater.....	17
Searchlight (STDB).....	18
02 Level Exterior	
Gyro Repeater (STBD).....	19
Pyrotechnic Signal Locker, Ammo Locker, Grenade MK3A1 Locker, and Grenade Fuse M206A1 Locker.....	20
Liferaft (STBD).....	21
Rescue/Workboat Outboard Motor.....	22
Rescue/Workboat.....	23
Rescue/Workboat Crane.....	24
Liferaft (Port).....	25
Liferaft (Midships).....	25.1
Communications Batteries.....	26
Gyro Repeater (Port).....	27
Pilothouse	
Searchlight Lever/Gear Control (STBD).....	28
Pilothouse Air Handling Unit.....	29
Gyro Compass.....	30
Pilothouse Console.....	31
Helm.....	32
Clearview Screens & Control.....	33
Searchlight Lever/Gear Control (Port).....	34
Battery Charger for Commo Batteries.....	35
Radio Receiver.....	35.1
Satellite Signal Navigation Set.....	35.2
Searchlight Power Supply.....	36
Marine Fire Detector Panel.....	37
Navigation Lighting System.....	38

<u>Compartment/Item To Be Inspected</u>	<u>Item No.</u>
01 Level Exterior	
Roller Fairlead (STBD).....	39
Stern Anchor Winch.....	40
Shore Power Terminal Box.....	41
Roller Fairlead (Port).....	42
Towing Hawser Reels (2).....	43
Emergency Generator Batteries.....	44
Aft Main Deck (Exterior)	
Shore Power Cable.....	45
Handling Davit.....	46
External Hull.....	47
Aft Main Deck (Interior)	
Marine Freezer.....	48
Marine Refrigerator.....	49
Microwave Oven.....	50
Dishwasher.....	51
Milk Dispenser.....	52
First Aid and Medical Supplies.....	53
16-Ton 240V Compressor.....	54
Stern Anchor Winch Hydraulic Fluid Tank.....	55
Emergency Generator.....	56
Emergency Generator Day Tank.....	57
Emergency Switchboard.....	58
Engine Room HALON 1301 Fire Suppression System.....	59
Cargo Deck	
External Hull (forward of superstructure, above waterline).....	60
Forecastle Deck	
Handling Davit (STBD).....	61
Bow Anchor Windlass (STBD).....	62
Fairlead Roller (STBD).....	63
Chain Stopper (STBD).....	64
Bow Ramp Controls.....	65
Bow Anchor Windlass Controller (STBD).....	66
Bow Anchor Windlass (Port).....	67
Fairlead Roller (Port).....	68
Chain Stopper (Port).....	69
Bow Anchor Windlass Controller (Port).....	70
Handling Davit (Port).....	71
Main Deck, Forward	
Paint Locker HALON 1301 Fire Suppression System.....	72
Bow Ramp.....	73
Bow Ramp Hydraulic Power Rack Assembly.....	74
Standard Bow Anchor Windlass Hydraulic Power Pack Assembly.....	75
Portable Firefighting Pump, Model PE-250.....	76

<u>Compartment/Item To Be Inspected</u>	<u>Item No.</u>
Steering Gear Compartment	
Steering Gear and Linkage.....	77
Electrohydraulic Steering System.....	78
Compass Repeater.....	79
Steering Gear Local Control Unit.....	80
Stern Anchor Winch Hydraulic Pump.....	81
Engine Room	
Engine Room and Interior Hull.....	82
Compressed Air Subsystem.....	83
Propeller-and-Propeller Shaft (Port).....	84
Reduction Gear (Port).....	85
Main Propulsion Engine (Port).....	86
Ship's Service Diesel Generator (Port).....	87
Fuel Filter/Coalescer.....	88
Fuel Transfer Hand Pump.....	89
Fuel Transfer Pumps.....	90
Fresh Water Pumps.....	91
Dirty Lube Oil Pump.....	92
Tank Level Indicators.....	93
Fire Pumps.....	94
Batteries.....	95
Battery Charger.....	96
Ship's Service Diesel Generator (STBD).....	97
Bilge/Ballast Pump.....	98
Sea Water Circulating Pump.....	99
Reduction Gear (STBD).....	100
Main Propulsion Engine (STBD).....	101
Propeller and Propeller Shaft (STBD).....	102
Marine Sanitation Device.....	103
STBD Reduction Gear Oil Cooling Pump.....	104
Prelube Oil Pump.....	105
Oil-Water Separator.....	106
Purifier Preheater.....	107
Lubricating Oil Purifier.....	108
Lubricating Oil Transfer Hand Pump.....	109
Fresh Water Makers.....	110
Port Reduction Gear Oil Cooling Pump.....	111
Engine Room Operating Station	
Marine Sanitation Device Monitor Panel.....	112
Engine Room Console.....	113
EOS Air Handling Unit.....	114
Main Switchboard.....	115
Machine Shop & Storeroom	
Bench Grinder.....	116
Arc Welder.....	117
Wet/Dry Vacuum.....	118
Tools, Spare Parts and Equipment.....	119

<u>Compartment/Item To Be Inspected</u>	<u>Item No.</u>
Engine Room (Forward) and Tunnel	
Ventilation Motor Control Center.....	120
Auxiliary Machinery Motor Control Center.....	121
Hydraulic Fluid Storage Tank.....	122
 Bowthruster Compartment	
Bowthruster Day Tank.....	123
Battery Box.....	124
Battery Charger.....	125
Manual Hand Pumps.....	126
Port Anchor Windlass Hydraulic Power Unit.....	127
Bowthruster Engine.....	128
Bowthruster Waterjet Set.....	129
Emergency Fire Pump.....	130

a. General To ensure that the LCU 2000 is ready for operation at all times, it must be systematically inspected so that defects may be discovered and corrected, preventing serious damage or failure. DA Form 2404 (Equipment Inspection and Maintenance Worksheet) will be used for the PMCS. All corrected faults will be recorded on DA Form 4640 (Deck Department Log) and DA Form 4993 (Engine Department Log). All uncorrected faults will be transcribed to DA Form 2407 (Maintenance Request) and the appropriate log. PMCS will be accomplished as outlined in Table 22. The LCU will be serviced in accordance with the intervals outlined in the PMCS, table.

- (1) Before You Operate. Required preventive maintenance services will be performed before operating (B). Any deficiencies noted will be corrected before equipment operation. Observe all WARNINGS and CAUTIONS.
- (2) While You Operate. During operation services (D) is a check on the vessel's performance. If any deficiencies are noted that will result in damage to the equipment, operation of that equipment will be stopped. Observe all WARNINGS and CAUTIONS.
- (3) After You Operate. After operation services (A) are the basic preventive maintenance services. Services will be performed at intervals based on normal operation of the equipment. Observe all WARNINGS and CAUTIONS.
- (4) If Your Equipment Fails to Operate. Report any deficiencies using the proper forms. See DA Pam 738-750.

b. PMCS Procedures The Preventive Maintenance Checks and Services table lists the inspections and care of the equipment required to keep it in good operating condition.

- (1) Interval Column. The interval column of the PMCS table indicates when to do a certain check or service.
- (2) Procedure Column. The procedure column of the PMCS table instructs who the required checks and services are performed. Carefully follow these instructions. If the required tools are not available or if the procedure directs, have organization maintenance do the work.

- (3) Equipment DoesNot Perform. If the equipment does not perform as required, refer to Chapter 3 under Troubleshooting for possible problems. Report any malfunctions or failures on the proper DA Form 2404, or refer to DA Pam 738-750.
- (4) First Time Operator. Perform weekly as well as before operations PMCS if:
  - (a) You are the assigned operator and have not operated the item since the last weekly.
  - (b) You are operating the item for the first time.
- (5) Equipment Is Not Ready/Available If: Column. This column tells you when and why your equipment cannot be used.

**NOTE**

The terms "ready/available" and "mission capable" refer to the same status: Equipment is on hand and is able to perform its combat mission (See DA Pam 738-750).

- (6) Leakage Classifications. Leakage definitions for operator/crew PMCS shall be classified as follows:
  - (a) Class I: seepage of fluid (as indicated by wetness or discoloration) not great enough to form drops.
  - (b) Class II: leakage of fluid great enough to form drops but not enough to cause ~~st~~topdrip from the item being checked/inspected.
  - (c) Class III: leakage of fluid great enough to form drops that fall from the item being checked/inspected.

**Table 2-2. Operator/Crew Preventive Maintenance Checks and Services**

**NOTE**

If the equipment must be kept in continuous operation, check and service only those items that can be checked and serviced without disturbing operation. Make the complete checks and services when the equipment can be shut down.

**B - Before                      D - During                      A - After                      W - Weekly                      M - Monthly**

ITEM NO	INTERVAL					ITEM TO BE INSPECTED	PROCEDURES CHECK FOR AND HAVE REPAIRED OR ADJUST AS NECESSARY	EQUIPMENT IS NOT READY/ AVAILABLE IF:
	B	D	A	W	M			
							<p style="text-align: center;"><b><u>WARNING</u></b></p> <p>Electrical Hazards. The electrical system and the pneumatic equipment system are dangerous when performing maintenance or inspections. Be sure to observe all warnings to prevent injury or possible death of personnel.</p> <p style="text-align: center;"><b><u>CAUTION</u></b></p> <p>Equipment operation is allowable with minor leakages (Class I or II). Consider the fluid capacity in the item/system being checked/inspected. When in doubt, notify the section supervisor.</p> <p>When operating with Class I or Class II leaks, continue to check fluid levels as required in the PMCS.</p> <p>Class III leaks should be reported to your supervisor or unit maintenance.</p> <p style="text-align: center;"><b><u>CAUTION</u></b></p> <p>Operating the equipment contrary to published instructions will cause damage and possible destruction of the equipment. Always be sure the equipment is operated properly.</p>	

Table 2-2. Operator/Crew Preventive Maintenance Checks and Service - CONT

B - Before                      D - During                      A - After                      W - Weekly                      M - Monthly

ITEM NO	INTERVAL					ITEM TO BE INSPECTED	PROCEDURES CHECK FOR AND HAVE REPAIRED OR ADJUST AS NECESSARY	EQUIPMENT IS NOT READY/ AVAILABLE IF:
	B	D	A	W	M			
1	I		I	I		General Craft Cleanliness	Inspect glass, frames and brackets for damage; clean windows, vents and ports. Inspect entire craft for cleanliness.	
2	I				I	Life Lines and Stanchions	Ensure life lines are in good condition, and are secured in place. Visually inspect safety chains for wear and corrosion. Ensure safety chains are utilized.	
3	I				I	Life Jackets	Life jackets shall be inspected for rips, oil stains, broken straps, fiber deterioration, and hull marking of vessel.  Check that light attached to jacket operates and that case is not damaged.	Life jackets are unserviceable.
4		I			I	Life Rings	Inspect for damage and proper marking. Check that marker lights function when casing is turned upright.	
5					I	Fire Pull Box	Inspect box and pull handles for damage. Document all defects and discrepancies and refer to unit maintenance.	Damage or condition exists which makes Fire Pull Box inoperable.
6						Fire Station and Foam Station	<b><u>WARNING</u></b>  During inspections, immediately report any defects to your supervisor and correct without delay or refer to unit maintenance.  Inspect fire hose in the hose rack for tears, fraying or cuts. Check nozzle and nozzle handle for proper operation.	

Table 2-2. Operator/Crew Preventive Maintenance Checks and Service - CONT

B - Before                      D - During                      A - After                      W - Weekly                      M - Monthly

ITEM NO	INTERVAL					ITEM TO BE INSPECTED	PROCEDURES CHECK FOR AND HAVE REPAIRED OR ADJUST AS NECESSARY	EQUIPMENT IS NOT READY/ AVAILABLE IF:
	B	D	A	W	M			
6						Fire Station and Foam Station - continued	Check hose connection at Fire Station Isolation valve for tightness. will not attach properly.	Hoses are defective or connections
7	I					Portable Fire Extinguisher	Inspect for tight mounting, full charge, corroded nozzles, and closed valves with untampered seals. Direct particular attention to extinguisher lines and nozzles in the engine room, checking for damage.	Extinguisher is damaged or seal is broken.
8	I					Doors, Hatches/Covers - Scuttles capability is impaired.	Inspect for proper installation, missing/defective fasteners, also check gasket for proper seal	Watertight integrity or operation
9	I					Intercom Exterior	Visually Inspect exterior for damage or dirt build-up. Clean using a soft cloth.	Damaged or defective parts.
	I					Hardware	Inspect mounting hardware for tightness. Tighten as necessary.	
		I				Rotary switches	Check mechanical operation of each rotary switch. Repeat any work parts or incorrectly operating parts	
			I			Unit performance	Check the two-way voice capability of the master station. Select other stations on the system and conduct a two-way conversation.	
		I				a. Transmissions and receptions should be clear, undistorted, and easily understood.		



Table 2-2. Operator/Crew Preventive Maintenance Checks and Service - CONT

B - Before                      D - During                      A - After                      W - Weekly                      M - Monthly

ITEM NO	INTERVAL					ITEM TO BE INSPECTED	PROCEDURES CHECK FOR AND HAVE REPAIRED OR ADJUST AS NECESSARY	EQUIPMENT IS NOT READY/ AVAILABLE IF:
	B	D	A	W	M			
9		I		I		Intercom - Continued	<p>b. Check the indicator lamps. The call lamps at the called station(s) should be lit. The REL lamp at the calling station should be lit. If called station is busy, the busy light should be lit.</p> <p>c. Check the control switches. Vary position of the dimmer control switch and observe intensity of the panel illumination. Vary VOLUME control switch during reception and verify intensity of the received speech is controlled.</p> <p>d. Check the hands free capability by operating hands free with another station in the system.</p> <p>Document all observed unit malfunctions and refer to unit maintenance.</p>	One or more unit malfunctions occur.
10					Sound Powered Telephones			
	I	I		I	a. Head Set-Chest Set	<p>Visually inspect head set connections to the chestset for frayed wiring on loose connections. Inspect ear cups for tears and cleanliness. Inspect neck straps for fraying or missing fasteners. Press pushbutton on mouthpiece and release. Observe pushbutton goes in and out. Visually inspect wire from chest set to jack plug for loose connections, cracks on damaged insulation.</p>		

Table 2-2. Operator/Crew Preventive Maintenance Checks and Service - CONT

B - Before                      D - During                      A - After                      W - Weekly                      M - Monthly

ITEM NO	INTERVAL					ITEM TO BE INSPECTED	PROCEDURES CHECK FOR AND HAVE REPAIRED OR ADJUST AS NECESSARY	EQUIPMENT IS NOT READY/ AVAILABLE IF:
	B	D	A	W	M			
10		I			I	Sound Powered Telephones - Continued	<p>Check the two-way voice capability of the headset. Select another station on the system and conduct a two-way conversation. Transmission and receptions should be clear, undistorted and easily understood.</p> <p>Document all observed discrepancies or unit malfunctions and refer to unit maintenance.</p>	
			I		I	b. Handset Exterior	Visually inspect the handset and wiring for loose connections. Tighten as necessary. Visually inspect exterior for damage or dirt buildup. Clean using a soft, clean cloth.	
					I	Hardware	Inspect mounting hardware for tightness. Tighten as necessary.	
			I		I	Rotary Switches	Check mechanical operation of each rotary switch. Document any worn part or incorrectly operating parts and refer to unit maintenance.	
			I			Operation	<p>Check the two-way voice capability of the unit Select other stations and conduct a two-way conversation.</p> <p>a. Transmissions and receptions should be clear, undistorted and easily understood.</p>	

Table 2-2. Operator/Crew Preventive Maintenance Checks and Service - CONT

B - Before                      D - During                      A - After                      W - Weekly                      M - Monthly

ITEM NO	INTERVAL					ITEM TO BE INSPECTED	PROCEDURES CHECK FOR AND HAVE REPAIRED OR ADJUST AS NECESSARY	EQUIPMENT IS NOT READY/ AVAILABLE IF:
	B	D	A	W	M			
10		I				Sound Powered Telephones - continued	b. Check the audible and light indicators. On models SELR and SFLR the indicator lights should light along with the calling signal. Document all observed unit malfunctions and refer to unit maintenance.	One or more malfunctions occur.
11	I	I	I			Power Distribution System	<p style="text-align: center;"><b><u>WARNING</u></b></p> <p>Electrical wiring, panels, and components contain high voltages that can cause severe injury or death.</p> <p style="text-align: center;"><b><u>NOTE</u></b></p> <p>Electrical wiring checks and services consist of visual inspections only. Observe all CAUTIONS and WARNING labels on electrical equipment.</p>	
						I Wiring	Visually inspect all accessible wiring, fuse terminal blocks, and connections. Ensure hardware and connections are securely supported, clean and undamaged. Visually inspect cables and wiring insulations. Ensure insulation is not worn, chafed or damaged. Visually inspect conduits and shielding. Ensure conduits are securely supported and undamaged; shielding is unfrayed and properly grounded.	
						I Panels	Inspect power and lighting panels, motor controllers, and other electrical panels for secure mounting. Visually inspect panel surface for damage.	Panel is not securely mounted or has damage which could affect operation.

Table 2-2. Operator/Crew Preventive Maintenance Checks and Service - CONT

B - Before                      D - During                      A - After                      W - Weekly                      M - Monthly

ITEM NO	INTERVAL					ITEM TO BE INSPECTED	PROCEDURES CHECK FOR AND HAVE REPAIRED OR ADJUST AS NECESSARY	EQUIPMENT IS NOT READY/ AVAILABLE IF:
	B	D	A	W	M			
12		I				HVAC Equipment	Check units for unusual noises and leaks	Unusual noises.
						Air Passages	Check unit for dust, lint and dirt buildup. Ensure all air passages are open.	
						Exterior	Check exterior of unit for wear, damage and corrosion.	
13						Piping	Visually inspect all piping for leaks. Pay particular attention to all valves, connections, joints, etc. Correct all leaks or document and report discrepancies/damage/ Class III leakage to engineer on watch and unit maintenance.	If Class III leakage is observed.
		I	I	I		Sanitary Spaces	Visually inspect all faucets on wash basins and showers for leaks. Inspect all commodes for leaks and stoppage. Inspect shower and wash basin drains are unstopped. If Class III leakage is observed or if drains or commodes are stopped, refer to supervisor and unit maintenance.	
14						<u>Pilothouse Top</u>		Mast is damaged to extent that navigational systems are not properly supported.
		I				Mast and Yardarm	Inspect for mechanical damage to navigational equipment and ensure lights are functional.	

Table 2-2. Operator/Crew Preventive Maintenance Checks and Service - CONT

B - Before                      D - During                      A - After                      W - Weekly                      M - Monthly

ITEM NO	INTERVAL					ITEM TO BE INSPECTED	PROCEDURES CHECK FOR AND HAVE REPAIRED OR ADJUST AS NECESSARY	EQUIPMENT IS NOT READY/ AVAILABLE IF:
	B	D	A	W	M			
15						500 Watt Searchlight (Port)	<p style="text-align: center;"><b><u>WARNING</u></b></p> <ul style="list-style-type: none"> <li>• High pressures exist inside lamp, especially when hot, and under certain conditions it could explode. Handle lamp only in its protective cover.</li> <li>• Remove protective cover from lamp before energizing circuits. Protect the eyes and wear gloves when removing cover from lamp. An industrial type face mask is recommended for eye and face protection.</li> <li>• Avoid direct exposure from the powerful direct and reflected radiations given off by the lamp. The front cover glass provides protection from these radiations.</li> <li>• Do not stand close in front of searchlight front cover glass when lamp is lighted. In the event of lamp explosion the front cover glass could break.</li> </ul> <p style="text-align: center;"><b><u>CAUTION</u></b></p> <p>Operation of lamp with finger marks or grease on the surface will cause deterioration of the quartz arc tube.</p> <p>Visually inspect lamp for blackening. If black, refer to unit maintenance for repair.</p>	
	I					Lamp		

Table 2-2. Operator/Crew Preventive Maintenance Checks and Service - CONT

B - Before                      D - During                      A - After                      W - Weekly                      M - Monthly

ITEM NO	INTERVAL					ITEM TO BE INSPECTED	PROCEDURES CHECK FOR AND HAVE REPAIRED OR ADJUST AS NECESSARY	EQUIPMENT IS NOT READY/ AVAILABLE IF:
	B	D	A	W	M			
15	I					500 Watt Searchlight (Port) - continued	Visually inspect for crack in the quartz. If a crack is detected. Refer corrective action to unit maintenance.	
					I	Reflector	Visually inspect for tarnishing, dirt buildup, or corrosion. Refer cleaning requirements to unit maintenance.	
					I	Front Cover Class	Visually inspect glass for defects or dirt buildup. Refer corrective action to unit maintenance.	
					I	Searchlight	Visually inspect the case for damage, dirt buildp, or corrosion. Refer corrective action to unit maintenance.	
16	I	I	I	I	Magnetic Compass	Check heading on two known courses. Check deviation when-ever metal structural changes are made to vessel; or when electronic equipment is added/removed. Check that deviation card is up to date and annual deviation card is located in immediate vicinity of compass. If damage is found, refer to Unit Maintenance.	Magnetic compass is in-operative. Compass will not swing freely in gimbal.	
17					Gyro Repeater			
				I	External	Visually inspect exterior surfaces are clean. If dirty clean with soft cloth.		

Table 2-2. Operator/Crew Preventive Maintenance Checks and Service - CONT

B - Before                      D - During                      A - After                      W - Weekly                      M - Monthly

ITEM NO	INTERVAL					ITEM TO BE INSPECTED	PROCEDURES CHECK FOR AND HAVE REPAIRED OR ADJUST AS NECESSARY	EQUIPMENT IS NOT READY/ AVAILABLE IF:
	B	D	A	W	M			
17					I	Gyro Repeater - continued Card window	Check for cleanliness and broken glass. If glass is broken, refer to unit maintenance.	Binnacle does not move freely in shock mount.
					I	Dimmer	Check dimmer controls illumination of repeater.	
					I	Shock mount	Check that binnacle moves freely in its shock mount. If binnacle binds or does not move refer to unit maintenance.	
18						500 Watt Searchlight (STBD)	<p style="text-align: center;"><b><u>WARNING</u></b></p> <ul style="list-style-type: none"> <li>• High pressures exist inside lamp, especially when hot, and under certain conditions it could explode. Handle lamp only in its protective cover.</li> <li>• Remove protective cover from lamp before energizing circuits. Protect the eyes and wear gloves when removing cover from lamp. An industrial type face mask is recommended for eye and face protection.</li> <li>• Avoid direct exposure from the powerful direct and reflected radiations given off by the lamp. The front cover glass provides protection from these radiations.</li> <li>• Do not stand close in front of searchlight front cover glass when lamp is lighted. In the event of lamp explosion the front cover glass could break.</li> </ul>	

Table 2-2. Operator/Crew Preventive Maintenance Checks and Service - CONT

B - Before                      D - During                      A - After                      W - Weekly                      M - Monthly

ITEM NO	INTERVAL					ITEM TO BE INSPECTED	PROCEDURES CHECK FOR AND HAVE REPAIRED OR ADJUST AS NECESSARY	EQUIPMENT IS NOT READY/ AVAILABLE IF:
	B	D	A	W	M			
18						500 Watt Searchlight (STBD) - continued	<p style="text-align: center;"><b>CAUTION</b></p> <p>Operation of lamp with finger marks or grease on the surface will cause deterioration of the quartz arc tube.</p> <p>Visually inspect lamp for blackening. If black, refer to unit maintenance for repair.</p> <p>Visually inspect for crack in the quartz. If a crack is detected, refer corrective action to unit maintenance.</p> <p>Visually inspect for tarnishing, dirt buildup, or corrosion. Refer cleaning requirements to unit maintenance.</p> <p>Visually inspect glass for defects or dirt buildup. Refer corrective action to unit maintenance.</p> <p>Visually inspect the case for damage, dirtbuildup, or corrosion. Refer corrective action to unit maintenance.</p>	
	I					Lamp		
	I							
					I	Reflector		
					I	Front Cover Glass		
					I	Searchlight		
19						<u>02 Level Exterior</u>	<p>Visually inspect exterior surfaces are clean. If dirty clean with soft cloth.</p> <p>Check for cleanliness and broken glass. If glass is broken, refer to unit maintenance.</p>	
					I	Gyro Repeater (STBD) External		
					I	Card window		



Table 2-2. Operator/Crew Preventive Maintenance Checks and Service - CONT

B - Before                      D - During                      A - After                      W - Weekly                      M - Monthly

ITEM NO	INTERVAL					ITEM TO BE INSPECTED	PROCEDURES CHECK FOR AND HAVE REPAIRED OR ADJUST AS NECESSARY	EQUIPMENT IS NOT READY/ AVAILABLE IF:
	B	D	A	W	M			
19						Gyro Repeater (STBD) - continued Dimmer	Check dimmer controls illumination of repeater.	
						Shock mount	Check that binnacle moves freely in its shock mount. If binnacle binds or does not move refer to unit maintenance.	Binnacle does not move freely in shockmount.
20						Pyrotechnic Signal Locker, Ammo Locker, Grenade MK3A1 Locker, and Grenade Fuse M206A1 Locker	Visually inspect lockers for damage or missing parts.	
21						Liferaft	<p style="text-align: center;"><b><u>WARNING</u></b></p> <p>During inspections and service, immediately report noted defects to your supervisor.</p> <p><u>YOUR LIFE AND THAT OF THE CREW</u> may depend on this equipment working in an emergency.</p> <p style="text-align: center;"><b><u>NOTE</u></b></p> <p>Servicing must be carried out every 12 months at a USCG approved facility and comply with requirements of USCG Specification 160.051, Para 6. Crew servicing is limited to visual inspections only.</p>	Labels are missing or unreadable.

Table 2-2. Operator/Crew Preventive Maintenance Checks and Service - CONT

B - Before                      D - During                      A - After                      W - Weekly                      M - Monthly

ITEM NO	INTERVAL					ITEM TO BE INSPECTED	PROCEDURES CHECK FOR AND HAVE REPAIRED OR ADJUST AS NECESSARY	EQUIPMENT IS NOT READY/ AVAILABLE IF:
	B	D	A	W	M			
21						Liferaft - continued	<p>WARNING</p> <p>Use caution when inspecting cylinder lanyard connected to eye bolt on deck. Accidentally pulling this cable will cause liferaft to inflate which could injure personnel or damage raft assembly.</p>	
		I		I		Container Exterior, Seals, Cables, Lanyards, Hydrostatic Release, Retainer Clips and Pins.	Visually inspect Container for bad dents or cracks which could leak water. Check cables and lanyards for chafing, cuts, or loose connectors. Document and report all defects and discrepancies to unit maintenance.	Damage or defect of Seals, Hydrostatic Release, or Retainer Clips and Pins which could cause liferaft to malfunction during emergency.
22					I	Rescue/Workboat Outboard Motor	<p>Visually inspect exterior for cleanliness. If dirty clean with clean soft cloth.</p> <p>a. Check tiller arm and throttle for loose fitting. Tighten loose fitting.</p> <p>b. Check gear shift lever. Shift gears into forward and reverse. If gear shift lever does not operate properly, refer to unit maintenance.</p> <p>c. Check propeller for debris, Debris, foreign foreign objects and loose or objects wedged broken fittings, bent or broken blades. Refer problems to unit maintenance. blade.</p>	or lodged on propeller. Broken or bent propeller
		I		I				
			I		I			
			I		I			

Table 2-2. Operator/Crew Preventive Maintenance Checks and Service - CONT

B - Before                      D - During                      A - After                      W - Weekly                      M - Monthly

ITEM NO	INTERVAL					ITEM TO BE INSPECTED	PROCEDURES CHECK FOR AND HAVE REPAIRED OR ADJUST AS NECESSARY	EQUIPMENT IS NOT READY/ AVAILABLE IF:
	B	D	A	W	M			
23					I	Rescue/Workboat	Visually inspect exterior for cleanliness. If dirty clean exterior with soft cloth and water. Check fiberglass bottom for cracks or holes. Check inflated chamber for leakage, cracks, or tears. Refer problems to unit maintenance.	Holes or cracks in fiberglass bottom or cracks or tears on inflated chamber.
24					I	Rescue/Workboat Crane	Inspect entire crane assembly for deterioration or visible defects. If damage is found or conditions appear questionable, report defects and discrepancies to unit, maintenance.	
		I				Operation	During operation, check crane for unusual sounds or malfunctioning. Refer to unit maintenance.	
					I	Exterior	Visually inspect the exterior of the crane. If dirty clean with rag and solvent.	
					I	Hook	Check hook for loose connection to wire cable. Tighten connection if needed.	
					I	Cable	Check cable for frays and corrosion.	
25						Liferaft (Port)	<p><b><u>WARNING</u></b></p> <p>During inspections and service, immediately report noted defects to your supervisor.</p> <p><b><u>YOUR LIFE AND THAT OF THE CREW</u></b> may depend on this equipment working in an emergency.</p>	Labels are missing or unreadable.

Table 2-2. Operator/Crew Preventive Maintenance Checks and Service - CONT

B - Before                      D - During                      A - After                      W - Weekly                      M - Monthly

ITEM NO	INTERVAL					ITEM TO BE INSPECTED	PROCEDURES CHECK FOR AND HAVE REPAIRED OR ADJUST AS NECESSARY	EQUIPMENT IS NOT READY/ AVAILABLE IF:
	B	D	A	W	M			
25						Liferaft (Port) - continued	<p style="text-align: center;"><b><u>NOTE</u></b></p> <p>Servicing must be carried out every 12 months at a USCG approved facility and comply with requirements of USCG Specification 160.051, Para. 6. Crew servicing is limited to visual inspections only.</p> <p style="text-align: center;"><b><u>WARNING</u></b></p> <p>Use caution when inspecting cylinder lanyard connected to eye bolt on deck. Accidentally pulling this cable will cause liferaft to inflate which could injure personnel or damage raft assembly.</p>	
						Container Exterior, Seals, Cables, Lanyards, Hydrostatic Release, Retainer Clips and Pins.	Visually inspect Container for bad dents or cracks which could leak water. Check cables and lanyards for chafing, cuts, or loose connectors. Document and report all defects and discrepancies to unit maintenance.	Damage or defect of Seals, Hydrostatic Release, or Retainer Clips and Pins which could cause liferaft to malfunction during an emergency. Labels are missing or
25.1						Liferaft (Midships) unreadable.	<p style="text-align: center;"><b><u>WARNING</u></b></p> <p>During inspections and service, immediately report noted defects to your supervisor.</p> <p><b><u>YOUR LIFE AND THAT OF THE CREW</u></b> may depend on this equipment working in an emergency.</p>	

Table 2-2. Operator/Crew Preventive Maintenance Checks and Service - CONT

B - Before                      D - During                      A - After                      W - Weekly                      M - Monthly

ITEM NO	INTERVAL					ITEM TO BE INSPECTED	PROCEDURES CHECK FOR AND HAVE REPAIRED OR ADJUSTED AS NECESSARY	EQUIPMENT IS NOT READY/ AVAILABLE IF:
	B	D	A	W	M			
25.1						Liferaft (Midships) - continued	<p align="center"><b>NOTE</b></p> <p>Servicing must be carried out every 12 months at a USCG approved facility and comply with requirements of USCG Specification 160.051, Para 6.Crew servicing is limited to visual inspections only.</p> <p align="center"><b>WARNING</b></p> <p>Use caution when inspecting cylinder lanyard connected to eye bolt on deck. Accidentally pulling this cable will cause liferaft to inflate which could injure personnel or damage raft assembly.</p>	
	I					Container Exterior, Seals, Cables, Lanyards, Hydrostatic Release, Retainer Clips and Pins.	Visually inspect Container for bad dents or cracks which could leak water. Check cables and lanyards for chafing, cuts, or loose connectors. Document and report all defects and discrepancies to unit maintenance.	Damage or defect of Seals, Hydrostatic Release, or Retainer Clips and Pins which could cause liferaft to malfunction during an emergency.
26						Communications Batteries	<p align="center"><b>WARNING</b></p> <p>Do not smoke when observing battery electrolyte level. Batteries give off fumes that can explode. Electrolyte is an acid and can cause personal injury if it contacts skin or eyes. Wear approved goggles, gloves, and apron.</p>	

Table 2-2. Operator/Crew Preventive Maintenance Checks and Service - CONT

B - Before                      D - During                      A - After                      W - Weekly                      M - Monthly

ITEM NO	INTERVAL					ITEM TO BE INSPECTED	PROCEDURES CHECK FOR AND HAVE REPAIRED OR ADJUSTED AS NECESSARY	EQUIPMENT IS NOT READY/ AVAILABLE IF:
	B	D	A	W	M			
25						Communications Batteries - continued		
	I		I	I		Batteries, cables and terminals	Inspect batteries, terminals, connections, cables and vent caps for cleanliness and tightness. Clean or tighten terminal connections as required. Clean battery as required.	
27					I	Electrolyte	Check electrolyte level with hydrometer.	
					I	Gyro Repeater (Port) External	Visually inspect exterior surfaces are clean. If dirty clean with soft cloth.	
					I	Card window	Check for cleanliness and broken glass. If glass is broken, refer to unit maintenance.	
					I	Dimmer	Check dimmer controls illumination of repeater.	
					I	Shock mount	Check that binnacle moves freely in its shock mount. If binnacle binds or does not move in shock mount refer to unit maintenance.	Binnacle does not move freely
28					I	<u>Pilothouse</u> Searchlight Lever/Gear Control (STBD)	Have another soldier observe searchlight. Operate lever to ensure searchlight moves in desired direction (horizontal and vertical). Operate locks to ensure they secure searchlight.	Controls do not perform any one function.

Table 2-2. Operator/Crew Preventive Maintenance Checks and Service - CONT

B - Before                      D - During                      A - After                      W - Weekly                      M - Monthly

ITEM NO	INTERVAL					ITEM TO BE INSPECTED	PROCEDURES CHECK FOR AND HAVE REPAIRED OR ADJUSTED AS NECESSARY	EQUIPMENT IS NOT READY/ AVAILABLE IF:
	B	D	A	W	M			
29	I	I				Engine Control Room - Air Handling Unit	Check unit for leaks and unusual noises.	Unusual noises.
					I		Check exterior of unit for wear, damage and corrosion.	
	I			I		Air Grille	Check air grille for dust or dirt buildup and restrictions.	
	I			I		Filter	Check filter for dust, lint and dirt buildup.	
30						Gyro Compass		Power loss to compass.
					I	Follow-Up Alarm Lamp	Check that light is OFF.	
					I	Caged lamp	Check that light is OFF. Latitude Control Check that control is set at local latitude.	
					I	North-Side (N-S) Switch	Check that switch is set at proper latitude.	
					I	Level Meter	Normal settled tilt indication	
					I	Azimuth Card Reading	Check that azimuth reading is within two degrees when settled.	
					I	Card Window	Check for cleanliness.	
					I	Fluid Level	Check that fluid has no bubbles Viewed in Window present. Refer to unit maintenance.	
					I	Master Compass	Check for oil seepage around any seam or seal. Refer to unit maintenance	
				I	Shock Mounts	Check that binnacle moves freely in its shock mounts.	Any class of oil leakage.	

Table 2-2. Operator/Crew Preventive Maintenance Checks and Service - CONT

B - Before                      D - During                      A - After                      W - Weekly                      M - Monthly

ITEM NO	INTERVAL					ITEM TO BE INSPECTED	PROCEDURES CHECK FOR AND HAVE REPAIRED OR ADJUSTED AS NECESSARY	EQUIPMENT IS NOT READY/ AVAILABLE IF:
	B	D	A	W	M			
31	I					Pilothouse Console	Inspect console for cleanliness, clean as required. Look for any loose, missing, or broken switches or controls, gauges, indicator lights, or obvious damage.	
					I	CRT-MCHRY SYSTEMS Monitor	Clean screen with window cleaner.	
		I				Panel Autopilot Control	Operate DIMMER to ensure control of lights.	
		I				Bowthruster Waterject Control Panel	Press LAMP CHECK pushbutton, ensure all lamps operate.	
		I				Engine Order Telegraph	Press DIMMER pushbutton, ensure intensity of lamps are adjustable.	
		I				Bow Ramp	Control HIGH TEMP light is out TENSION Panellight is out. Run light is lit.	
						Bridge Console Panel	a. Press POWER ON LAMP TEST, all panel lamps should be lit.  b. Press DIFFER pushbutton, ensure intensity of lamps are adjustable.	
32	I				I	Helm	Visually inspect helm for obvious damage.	Any damage which could effect operation.
		I				Operation	Ensure helm operates smoothly and does not bind.	Any binding or unusual operation.



Table 2-2. Operator/Crew Preventive Maintenance Checks and Service - CONT

B - Before                      D - During                      A - After                      W - Weekly                      M - Monthly

ITEM NO	INTERVAL					ITEM TO BE INSPECTED	PROCEDURES CHECK FOR AND HAVE REPAIRED OR ADJUSTED AS NECESSARY	EQUIPMENT IS NOT READY/ AVAILABLE IF:
	B	D	A	W	M			
33	I				I	Clearview Screens Control Panel Exterior	Visually inspect exterior for obvious damage.	
		I			I	Operation	a. Turn on each SPIN switch, ensure each screen spins.  b. Turn-on each HTR switch, place hand near but not on screen to ensure each screen heater is working.	Any heater does not work.
34				I		Searchlight Lever/Gear Control (port)	Have another soldier observe searchlight. Operate lever to ensure searchlight moves in desired direction (horizontal and vertical). Operate locks to ensure they secure searchlight.	Controls do not perform any one function.
35	I	I	I		I	Battery Charger for Communications Battery	Check battery charger for proper connections to battery. Ammeter should read near 0 for a trickle charge. If the reading is above 3 AMPS, refer to unit maintenance.  NOTE A high reading indicates the batteries are weak and are being recharged or that one or more batteries are unserviceable.	

Table 2-2. Operator/Crew Preventive Maintenance Checks and Service - CONT

B - Before                      D - During                      A - After                      W - Weekly                      M - Monthly

ITEM NO	INTERVAL					ITEM TO BE INSPECTED	PROCEDURES CHECK FOR AND HAVE REPAIRED OR ADJUSTED AS NECESSARY	EQUIPMENT IS NOT READY/ AVAILABLE IF:
	B	D	A	W	M			
35.1					I	Radio Receiver	<p style="text-align: center;"><b>CAUTION</b></p> <p>Do not remove the covers from the radio receiver. Exposed components may be damaged by static electricity if not properly handled.</p> <p>Check that battery life has not expired. Replace batteries every 180 days. Refer to TM 11-5826-311-12-2-1.</p>	Batteries are dead.
35.2		I				Satellite Signal Navigation Set	<p>Perform the keyboard/display test when the keyboard or the data display appears to work incorrectly. Refer to TM 11-5826-311-12-2-2.</p>	Fault not corrected.

Table 2-2. Operator/Crew Preventive Maintenance Checks and Service - CONT

B - Before                      D - During                      A - After                      W - Weekly                      M - Monthly

ITEM NO	INTERVAL					ITEM TO BE INSPECTED	PROCEDURES CHECK FOR AND HAVE REPAIRED OR ADJUSTED AS NECESSARY	EQUIPMENT IS NOT READY/ AVAILABLE IF:
	B	D	A	W	M			
36						Searchlight Power Supply	<p><u>WARNING</u></p> <p>On initial startup, DO NOT energize circuit before first checking to ensure that the protective lamp cover has been removed. Use extreme care when performing maintenance work, making adjustments or operating the searchlight, etc., because dangerous high voltage (over 50,000) radio frequency power is used in the lamp starting circuit. Be sure to observe all WARNINGS to prevent injury or possible death of personnel.</p>	
		I				Fan	Check for air flow at exhaust openings when searchlight is turned ON. If air flow is not detected, refer corrective action to unit maintenance.	Fan is not operating.
		I				Ammeter	Check ammeter for correct current reading (22 amps). If adjustments are required, refer to unit maintenance.	Lamp current is not correct.
			I			Power Supply Case	Visually inspect case for damage, wear, or dirt buildup. Refer damage or cleaning requirements to unit maintenance.	
				I		Elapsed Time Meter	Check to determine if lamp should be replaced. (Recommended replacement time is 1500 to 1600 hrs elapsed time). Refer lamp replacement to unit maintenance.	

Table 2-2. Operator/Crew Preventive Maintenance Checks and Service - CONT

B - Before                      D - During                      A - After                      W - Weekly                      M - Monthly

ITEM NO	INTERVAL					ITEM TO BE INSPECTED	PROCEDURES CHECK FOR AND HAVE REPAIRED OR ADJUSTED AS NECESSARY	EQUIPMENT IS NOT READY/ AVAILABLE IF:
	B	D	A	W	M			
36						Searchlight Power Supply - continued	NOTE  A used lamp should be considered for use in emergency situations. Properly protect, store and identify lamp as a spare.	
37				I		Marine Fire Detector Panel	Push RESET-LAMP TEST push-button. All lamps should light.	One or more lamps do not
light.		I				D.C. VOLTS	Voltmeter should read 24-30V.	
			I			D. C. AMPERES	Ampmeter should read near 0.	
	I	I		I		Navigation Lighting System	Visually inspect to ensure that Lights are all lights operate properly when the respective light switches on the navigation light panel are in the ON position. Refer corrective actions to unit maintenance.	inoperative. Circuits are defective.
39	I	I		I		Roller Fairlead (STBD)	Inspect roller to ensure it rotates freely. Check to ensure the base is securely mounted. For lubrication refer to LO 55-1905-223-12.	
40	I	I				Stern Anchor Winch	Check spools, gears and clutches for foreign object.	Foreign objects are wedged or lodged in assemblies.
	I		I	I		Planetary Reducer	Check planetary reducer for oil leaks.	Class III leaks.
	I		I	I		Hydraulic Lines	Check hydraulic lines, fittings and controls for leaks.	Class III leaks.

Table 2-2. Operator/Crew Preventive Maintenance Checks and Service - CONT

B - Before                      D - During                      A - After                      W - Weekly                      M - Monthly

ITEM NO	INTERVAL					ITEM TO BE INSPECTED	PROCEDURES CHECK FOR AND HAVE REPAIRED OR ADJUSTED AS NECESSARY	EQUIPMENT IS NOT READY/ AVAILABLE IF:
	B	D	A	W	M			
40						Stern Winch - continued	Anchor  <b>WARNING</b> Refer dripping oil and hydraulic fluid leaks to your supervisor and unit maintenance.	
	I	I	I			Wire Rope	Check cable for damage or corrosion.	
41	I					Shore Terminal Box	<b>WARNING</b> Defer PMCS when shore power operation is in progress. High voltages could cause serious injury or death.	
						VISUALLY INSPECT BOX EXTERIOR FOR DAMAGE AND CORROSION. ENSURE BOX IS SECURELY FASTENED TO BULKHEAD. REMOVE SCREWS SECURING BOX COVER AND OPEN FOR INSPECTION OF INTERIOR.	Visually check cable connectors (internal) for damage and corrosion.	
42	I	I		I		Roller Fairlead (Port)	Inspect roller to ensure it rotates freely. Check to ensure that base is securely mounted. For lubrication refer to LO 55-1905-223-12.	
43	I	I		I		Towing Hauser Reels (2) freely.	Inspect reels for obvious damage. Ensure reels rotate	

Table 2-2. Operator/Crew Preventive Maintenance Checks and Service - CONT

B - Before                      D - During                      A - After                      W - Weekly                      M - Monthly

ITEM NO	INTERVAL					ITEM TO BE INSPECTED	PROCEDURES CHECK FOR AND HAVE REPAIRED OR ADJUSTED AS NECESSARY	EQUIPMENT IS NOT READY/ AVAILABLE IF:
	B	D	A	W	M			
44						Emergency Generator Batteries	<p><b><u>WARNING</u></b></p> <p>Do not smoke when observing battery electrolyte level. Batteries give off fumes that can explode. Electrolyte is an acid and can cause personal injury if it contacts skin or eyes. Wear approved goggles, gloves, and apron.</p>	
	I		I	I		Batteries, cables and terminals	Inspect batteries, terminals, connections, cables and vent caps for cleanliness and tightness. Clean or tighten terminal connections as required. Clean battery as required.	
					I	Electrolyte	Check electrolyte level with hydrometer.	
45						<u>Aft Main Deck (Exterior)</u>		
	I					Shore Power Cable	<p><b><u>WARNING</u></b></p> <p>Defer PMCS when shore power operation is in progress. High voltages could cause serious injury or death.</p>	
							Visually check condition of cable. Check for cracked or damaged insulation.	
	I						Check condition of cable connection. Ensure connector is protected from moisture, dirt buildup and corrosion.	

Table 2-2. Operator/Crew Preventive Maintenance Checks and Service - CONT

B - Before                      D - During                      A - After                      W - Weekly                      M - Monthly

ITEM NO	INTERVAL					ITEM TO BE INSPECTED	PROCEDURES CHECK FOR AND HAVE REPAIRED OR ADJUSTED AS NECESSARY	EQUIPMENT IS NOT READY/ AVAILABLE IF:
	B	D	A	W	M			
46	I	I	I		I	Handling Davit (Portable) Line and Block & Tackle	Check davit block and tackle for foreign objects or obvious damage. Check line for fraying or lodged in or signs of wear.	Foreign objects remain wedged assemblies.  Damage or condition exists which makes davit unsafe for use.
						Davit Assembly	Inspect entire davit assembly for deterioration or visible defects. If damage found or conditions appear questionable, report defects and discrepancies to unit maintenance.	
						Socket	Inspect davit socket for rust and/or corrosion.	
47	I				I	External Hull (Aft section above waterline)	Inspect for structural damage.	Watertight integrity or operational capability is impaired.
48						Aft Main Deck (Interior)		
						Marine Freezer		
				I		Condenser Coil	Inspect condenser coil to make certain that air flow is not hampered and that it is clear of dust and debris.	
					I	Drain Line	Inspect and check that drain line is unstopped.	
		I				Temperature gauge	Check the temperature gauge to ensure the interior temperature is -10°F.	
					I	Interior Liner clean and dry.	Check that interior liner is	

Table 2-2. Operator/Crew Preventive Maintenance Checks and Service - CONT

B - Before                      D - During                      A - After                      W - Weekly                      M - Monthly

ITEM NO	INTERVAL					ITEM TO BE INSPECTED	PROCEDURES CHECK FOR AND HAVE REPAIRED OR ADJUSTED AS NECESSARY	EQUIPMENT IS NOT READY/ AVAILABLE IF:
	B	D	A	W	M			
48						Marine Freezer - continued		
					I	Condenser and Evaporator Fan Motors	Check both the condenser fan motor and the evaporator fan motor to make certain that they are operational and that the fans are tight and secure.	Unusual noise or vibration.
					I	Door gaskets	Check that door gaskets are clean and serviceable.	
					I	Exterior Surfaces	Check that exterior surfaces are clean and dry.	
49						Marine Refrigerator		
					I	Condenser Coil	Inspect condenser coil to make certain that air flow is not hampered and that it is clear of dust and debris.	
					I	Drain Line	Inspect and check that drain line is unstopped.	
					I	Temperature gauge	ensure the interior temperature is 35°F.	
					I	Interior Liner	Check that interior liner is clean and dry.	
					I	Condenser and Evaporator Fan Motors	Check both the condenser fan motor and the evaporator fan motor to make certain that they are operational and that the fans are tight and secure.	
					I	Door gaskets	Check that door gaskets are clean and serviceable.	



Table 2-2. Operator/Crew Preventive Maintenance Checks and Service - CONT

B - Before                      D - During                      A - After                      W - Weekly                      M - Monthly

ITEM NO	INTERVAL					ITEM TO BE INSPECTED	PROCEDURES CHECK FOR AND HAVE REPAIRED OR ADJUSTED AS NECESSARY	EQUIPMENT IS NOT READY/ AVAILABLE IF:
	B	D	A	W	M			
49						Marine Refrigerator - continued		
					I	Exterior Surfaces	Check that exterior surfaces are clean and dry.	
50						Microwave Oven		
						Exterior Surfaces	Clean the outside of the oven of grease and soil build-up.	
			I			Oven Face and Interior Surfaces	Check the oven face and interior surfaces for grease and soil build-up.	
			I			Oven	Odors can be eliminated from the inside of the oven by boiling a solution of one cup of water and several table-spoons of lemon juice in the oven for 5-7 minutes. Wipe out excess moisture after every use.	
			I			Air Filter	Clean air filter by washing in detergent and water, then dry and replace.	
51						Dishwasher		
					I	Exterior	Inspect for cleanliness. Clean as required.	
						Interior	Inspect for cleanliness. Clean as required.	
		I				Detergent Tank	Check that detergent tank is full. Add detergent as required.	

Table 2-2. Operator/Crew Preventive Maintenance Checks and Service - CONT

B - Before                      D - During                      A - After                      W - Weekly                      M - Monthly

ITEM NO	INTERVAL					ITEM TO BE INSPECTED	PROCEDURES CHECK FOR AND HAVE REPAIRED OR ADJUSTED AS NECESSARY	EQUIPMENT IS NOT READY/ AVAILABLE IF:
	B	D	A	W	M			
51						Dishwasher - continued		
		I				Detergent System Fittings	Check that all fittings are airtight.	
			I			Interior	At the conclusion of a wash cycle, check to ensure that the interior has been cleaned of grease, dust, and lint.	
52			I			Grease Collecting Gutter	Check the grease-collecting gutter for any foreign material.	
						Milk Dispenser		
		I				Exterior	Check cabinet each day for cleanliness.	
			I			Dispenser Valve	Inspect valves to ensure they are secure on valve holders.	
			I			Compressor	Inspect for proper operation of compressor. Report abnormal compressor noises to unit maintenance.	Unusual noise or vibration.
				I		Duct Panel	Inspect air duct panel and beneath unit for restrictions.	
				I		Condenser	Remove rear panel and clean condenser area.	
53	I				I	First Aid and Medical Supplies	Inspect and check contents in the first aid kit (with itemized list of contents in container) for completeness and serviceability. Check for shortage or damage to items and replace. Inventory medical supplies in sick bay.	First aid kit not complete.

Table 2-2. Operator/Crew Preventive Maintenance Checks and Service - CONT

B - Before                      D - During                      A - After                      W - Weekly                      M - Monthly

ITEM NO	INTERVAL					ITEM TO BE INSPECTED	PROCEDURES CHECK FOR AND HAVE REPAIRED OR ADJUSTED AS NECESSARY	EQUIPMENT IS NOT READY/ AVAILABLE IF:
	B	D	A	W	M			
54						16-Ton 240V Compressor	Check compressor for leaks, unusual noises, and obvious damage.	Class III leaks or unusual noise.
55	I		I	I		Stern Anchor Winch Hydraulic Fluid Tank	Check fluid level, filter condition and hydraulic pressure.	Fluid is low, filter condition indicator is in red or if hydraulic pressure exceeds 2000 psi.
56						Emergency Generator	<p><b>CAUTION</b></p> <p>Refer low fluid level, no filtration, and excessive hydraulic pressure readings to unit maintenance.</p> <p><b>WARNING</b></p> <p>The Manual, Automatic, Stop and Off/Reset switch on the control panel must be set at "Stop" position when performing maintenance or repair work on a standby generator set. This prevents the unit from starting if a power failure or voltage drop should occur while working on the unit. Failure to comply could result in personnel injury or death.</p> <p><b>NOTE</b></p> <p>The standby generator set may not be needed very often, but when it is, it is usually under emergency conditions. Maintenance of this standby unit is essential. It must always be maintained in excellent operating condition, ready to work under load at any time.</p>	

Table 2-2. Operator/Crew Preventive Maintenance Checks and Service - CONT

B - Before                      D - During                      A - After                      W - Weekly                      M - Monthly

ITEM NO	INTERVAL					ITEM TO BE INSPECTED	PROCEDURES CHECK FOR AND HAVE REPAIRED OR ADJUSTED AS NECESSARY	EQUIPMENT IS NOT READY/ AVAILABLE IF:
	B	D	A	W	M			
56						Emergency Generator - continued		
	I					Engine	Check the engine, radiator and generator for debris, foreign objects, loose or broken fittings, guards and components. Refer to TM 55-1905-223-24-4.	Broken parts or foreign objects wedged or lodged in components.
	I					Belts	Inspect for worn, broken or loose belts.	Belts are unserviceable.
							<b>WARNING</b>	
							<ul style="list-style-type: none"> <li>• At operating temperature, engine coolant is hot and under pressure and can cause personal injury.</li> <li>• Check coolant level ONLY when engine is stopped and radiator cap is cool enough to touch with your hand. Remove filler cap slowly to relieve pressure.</li> <li>• Cooling system conditioner contains alkali. Avoid contact with skin and eyes to prevent personal injury.</li> </ul>	
	I					Cooling System	Check for proper level.	Coolant level low.
I				I	Block Heater	Check block heater for proper operation. Place hand near, but not on the block; warmth should be felt.	Block is not warm.	
		I			Leaks	Check for leaks and unusual noises.	Class III leaks.	

Table 2-2. Operator/Crew Preventive Maintenance Checks and Service – CONT

B – Before      D – During      A – After      W – Weekly      M- Monthly

ITEM NO.	INTERVAL					ITEM TO BE INSPECTED	PROCEDURES CHECK FOR AND HAVE REPAIRED OR ADJUSTED AS NECESSARY	EQUIPMENT IS NOT READY/ AVAILABLE IF:
	B	D	A	W	M			
56						Emergency Generator – cont.		
	•					Oil Level	Check that oil level is between the add and full marks on the dipstick. Add oil if required. Refer to LO 55-1905-223-12.	Oil level is low.
	•					Fuel System	Check for fuel system leaks. Check fuel filters for moisture and sediment by draining ½ pint of fuel. Refer defects to unit maintenance.	Class III leakage.
	•					Gauges	Check the condition of all gauges for broken lenses, damaged frames and brackets.	
	•					Battery Charger	Check battery charger for proper connections to batteries. Ammeter should read near 0 for a trickle charge. If the reading is above 3 AMPs, refer to unit maintenance.	
							<b>NOTE</b>	
							<b>A high reading indicates the batteries are weak and are being recharged or that one or more batteries are unserviceable.</b>	
		•				Oil Pressure	Check gauge for proper oil pressure (35 to 70 psi).	Low oil pressure.
		•				Fuel Pressure	Check gauge for proper fuel pressure NORMAL (green) range.	Fuel pressure not within NORMAL (green) range.

Table 2-2. Operator/Crew Preventive Maintenance Checks and Service – CONT

B – Before      D – During      A – After      W – Weekly      M- Monthly

ITEM NO.	INTERVAL					ITEM TO BE INSPECTED	PROCEDURES CHECK FOR AND HAVE REPAIRED OR ADJUSTED AS NECESSARY	EQUIPMENT IS NOT READY/ AVAILABLE IF:
	B	D	A	W	M			
56		•	•			Emergency Generator – cont.  Cooling System  Switches  Battery Charger	Check gauge for proper operating coolant temperature (170 to 195°F).  Check that all switches are in proper positions. Refer to Chapter 2, Section I, Table 2-1, FIGURE 2-44.  Check that battery charger is reconnected if previously disconnected. notify engineer on watch. Ammeter should read near 0 for a trickle charge. If the reading is above 3 AMPS, refer to unit maintenance.	Temperature more than 196°F
57					•	Emergency Generator Day Tank	Visually inspect tank for leaks.	Class III leakage.
58	•			•		Emergency Switchboard	Visually inspect exterior of switchboard for damaged or missing circuit breakers, meters, controls or lights.	Any part is missing or meters are un-serviceable.
<b>NOTES</b>								
<p><b>Not applicable to vessels with FM-200 Fire Suppressant System installed. Reference para. 2-46 and 2-47 for FM-200 and Water Wash-down System operation. Ref. TM 55-1905-243-24&amp;P for maintenance and installation of FM-200 components.</b></p> <p><b>Part of the system is located in the Air Conditioning and Emergency Generator Room with the remainder in the Engine Room.</b></p>								
59	•				•	Engine Room HALON 1301 Fire Suppression System	During periods of extreme heat, fire extinguishers may release a portion of their charge through the discharge nozzles. Visually inspect nozzles for evidence of discharge or leaks.	

Table 2-2. Operator/Crew Preventive Maintenance Checks and Service - CONT

B - Before                      D - During                      A - After                      W - Weekly                      M - Monthly

ITEM NO	INTERVAL					ITEM TO BE INSPECTED	PROCEDURES CHECK FOR AND HAVE REPAIRED OR ADJUSTED AS NECESSARY	EQUIPMENT IS NOT READY/ AVAILABLE IF:
	B	D	A	W	M			
59						Engine Room HALON 1301 Fire Suppression System - Continued  I System Components  I Distribution System  I Access and Control Boxes  I Pressure Gauges  <u>Cargo Deck</u>	Check the system components to ensure that accidental damage to equipment has not occurred. Ensure cylinder straps are securely mounted.  Check for obstructions to the overhead discharge nozzles.  Ensure that access to the extinguisher assembly and all control pull boxes are unobstructed.  Check extinguisher assembly pressure gauges for proper operating pressure between 340 to 380 psi.	
60	I				I	<u>External Hull</u> (forward of superstructure, above waterline) impaired. <u>Forecastle Deck</u>	Inspect for structural damage.	Watertight integrity or operational capability is
61						Handling Davit (Portable)(STBD)  I Line and Block & Tackle	Check davit block and tackle for foreign objects or obvious damage. Check line for fraying or signs of wear	Foreign objects remain wedged or lodged in assemblies.

Table 2-2. Operator/Crew Preventive Maintenance Checks and Service - CONT

B - Before                      D - During                      A - After                      W - Weekly                      M - Monthly

ITEM NO	INTERVAL					ITEM TO BE INSPECTED	PROCEDURES CHECK FOR AND HAVE REPAIRED OR ADJUSTED AS NECESSARY	EQUIPMENT IS NOT READY/ AVAILABLE IF:
	B	D	A	W	M			
61						Handling Davit (Portable) (STBD) - continued		
					I	Davit Assembly	Inspect entire davit assembly for deterioration or visible defects. If damage found or conditions appear questionable, report defects and discrepancies to unit maintenance.	Damage or condition exists which makes davit unsafe for use.
					I	Socket	Inspect davit socket for rust and/or corrosion.	
62	I		I			Bow Anchor Windlass (STBD) Windlass	Check gypsies, wildcat drum, and clutches for foreign objects or obvious damage.	Class III leakage.
	I			I		Gearcase, hydraulic lines and fittings	Check for leaks	Class III leakage.
63	I	I		I		Fairlead Roller (STBD)	Inspect roller to ensure it rotates freely. Check to ensure the base is securely mounted. For lubrication refer to LO 55-1905-223-12.	
64		I				Chain Stopper (STBD)	Observe operation of chain stopper. Look for binding during operation or damage (e.g. cracks, or broken parts).	
65	I				I	Bow Ramp Controls Exterior	Visually inspect exterior for obvious damage or missing parts.	Damage prevents operation.
		I				Operation	Ensure Bow Ramp responds properly to Control Box.	Unit fails to operate properly.



Table 2-2. Operator/Crew Preventive Maintenance Checks and Service - CONT

B - Before                      D - During                      A - After                      W - Weekly                      M - Monthly

ITEM NO	INTERVAL					ITEM TO BE INSPECTED	PROCEDURES CHECK FOR AND HAVE REPAIRED OR ADJUSTED AS NECESSARY	EQUIPMENT IS NOT READY/ AVAILABLE IF:
	B	D	A	W	M			
66						Bow Anchor Windlass Controller (STBD)		
	I				I	Exterior	Visually inspect exterior for obvious damage or missing parts.	Damage prevents operation.
		I				Operation	Ensure Bow Anchor Windlass responds properly to Control Box.	Unit fails to operate properly.
	I		I			Windlass	Check gypsies, wildcat drum, and clutches for foreign objects or obvious damage.	Class III leakage.
	I			I		Gearcase, hydraulic lines and fittings.	Check for leaks.	Class III leakage.
67						Bow Anchor Windlass (Port)		
	I		I			Windlass	Check gypsies, wildcat drum, and clutches for foreign objects or obvious damage.	Class III leakage.
	I			I		Gearcase, hydraulic lines and fittings	Check for leaks	Class III leakage.
68	I	I		I		Fairlead Roller (Port)	Inspect roller to ensure it rotates freely. Check to ensure the base is securely mounted. For lubrication refer to LO 55-1905-223-12.	
69		I				Chain Stopper (Port)	Observe operation of chain stopper. Look for binding during operation or damage (e.g. cracks, or broken parts).	

Table 2-2. Operator/Crew Preventive Maintenance Checks and Service - CONT

B - Before                      D - During                      A - After                      W - Weekly                      M - Monthly

ITEM NO	INTERVAL					ITEM TO BE INSPECTED	PROCEDURES CHECK FOR AND HAVE REPAIRED OR ADJUSTED AS NECESSARY	EQUIPMENT IS NOT READY/ AVAILABLE IF:
	B	D	A	W	M			
70						Bow Anchor Windlass Controller (Port)		
	I					Exterior	Visually inspect exterior for obvious damage or missing parts.	Damage prevents operation.
		I				Operation	Ensure Bow Anchor Windlass responds properly to Control Box.	Unit fails to operate properly.
	I		I			Windlass	Check gypsies, wildcat drum, and clutches for foreign objects or obvious damage.	Class III leakage.
	I			I		Gearcase,	Check for leaks. hydraulic lines and fittings.	Class III leakage.
71						Handling Davit (Portable)(Port)		
	I	I	I			Line and Block & Tackle	Check davit block and tackle for foreign objects or obvious damage. Check line for fraying or lodged in or signs of wear.	Foreign objects remain wedged assemblies.
					I	Davit Assembly	Inspect entire davit assembly for deterioration or visible defects. If damage found or conditions appear questionable, report defects and discrepancies to unit maintenance.	Damage or condition exists which makes davit unsafe for use.
					I	Socket	Inspect davit socket for rust and/or corrosion.	

Table 2-2. Operator/Crew Preventive Maintenance Checks and Service – CONT

B – Before      D – During      A – After      W – Weekly      M- Monthly

ITEM NO.	INTERVAL					ITEM TO BE INSPECTED	PROCEDURES CHECK FOR AND HAVE REPAIRED OR ADJUSTED AS NECESSARY	EQUIPMENT IS NOT READY/ AVAILABLE IF:	
	B	D	A	W	M				
72	•					<p><u>Main Deck Forward</u></p>	<p style="text-align: center;"><b>NOTE</b></p> <p>Not applicable to vessels with FM-200 Fire Suppressant System installed. Reference para. 2-46 and 2-47 for FM-200 and Water Wash-down System operation. Ref. TM 55-1905-243-24&amp;P for maintenance and installation of FM-200 components.</p> <p style="text-align: center;"><b>NOTES</b></p> <p>During periods of extreme heat, fire extinguishers may release a portion of their charge through the discharge nozzles. Visually inspect nozzles for evidence of discharge or leaks.</p> <p>The two HALON 1301 fire suppression systems operate independently and service the main engine room and the paint locker. Each system is designed to provide an adequate amount of fire retardant material for the space protected.</p>		
						• Paint Locker HALON 1301 Fire Suppression System			Periodic inspections of the fire suppression system should be made to ensure efficient operation at all times.
						• System Components			Check the system components to ensure accidental damage to equipment has not occurred. Ensure cylinder straps are securely mounted.
						• Distribution System			Check for obstructions to the overhead discharge nozzles.
					• Access and Control Boxes	Ensure access to the extinguisher assembly and all control pull boxes are unobstructed.			

Table 2-2. Operator/Crew Preventive Maintenance Checks and Service – CONT

B – Before      D – During      A – After      W – Weekly      M- Monthly

ITEM NO.	INTERVAL					ITEM TO BE INSPECTED	PROCEDURES CHECK FOR AND HAVE REPAIRED OR ADJUSTED AS NECESSARY	EQUIPMENT IS NOT READY/ AVAILABLE IF:
	B	D	A	W	M			
72						Paint Locker HALON 1301 Fire Suppression System - continued  • Pressure Gauges	. Check extinguisher assembly pressure gauges for proper operating pressure between 340 to 380 psi.	
73	•		•			• Bow Ramp  • Sealing Gasket	Inspect entire ramp and related components including wire rope, ramp hinges, sheave assemblies, locking bars and ratchet dogs for proper adjustments, damage or excessive wear. If unserviceable component is identified, refer to supervisor and unit maintenance.  Inspect sealing gasket for damage from contact with cargo or for accumulations of foreign matter such as grit, oil, paint, etc. In addition, gasket should be checked for cracks and flexibility to ensure a good seal.	Evidence exists that proper and safe operation is not possible.  With ramp closed, water-tight fit is not achieved.
74	•					Bow Ramp Hydraulic Power Pack Assembly  a. Hydraulic Fluid Level Indicator mark  b. Pressure Gauge	Check hydraulic power pack for debris, foreign objects and loose or broken fittings.  Check fluid level with hydraulic power pack operating. Fluid level should be full.  Turn pressure gauge shutoff valve on. Hydraulic pressure should read 2900 psi.	Class III leakage is present.

Table 2-2. Operator/Crew Preventive Maintenance Checks and Service - CONT

B - Before                      D - During                      A - After                      W - Weekly                      M - Monthly

ITEM NO	INTERVAL					ITEM TO BE INSPECTED	PROCEDURES CHECK FOR AND HAVE REPAIRED OR ADJUSTED AS NECESSARY	EQUIPMENT IS NOT READY/ AVAILABLE IF:
	B	D	A	W	M			
74						Bow Ramp Hydraulic Power Pack Assembly - continued		
			I			c. Temperature Level Sensor	Check fluid temperature with hydraulic power pack operating. Temperature should be at, or below, 150°F.	
		I				Bow Ramp Winch Assembly	Check for loose or broken brackets, leaking fittings, or other unusual conditions.	
		I				a. Oil Level	Check for oil visible in sight glass.	
					I	b. Outboard Drum bearing	Check for outboard drum bearing lubrication. Refer to LO 55-1905-223-12.	
					I	c. Slack Wire	Check for slack wire limit switch lubrication. Refer to LO 55-1905-223-12.	
				I	d. Interlock Switch	Check for interlock switch lubrication. Refer to LO 55-1905-223-12.		
						<b>NOTE</b>		
						Refer dripping oil and hydraulic fluid leaks to your supervisor and unit maintenance.		
75	I					Starboard Bow	Check hydraulic power pack for Anchor Windless debris, foreign objects, and Hydraulic Power loose or broken fittings. Pack Assembly	

Table 2-2. Operator/Crew Preventive Maintenance Checks and Service - CONT

B - Before                      D - During                      A - After                      W - Weekly                      M - Monthly

ITEM NO	INTERVAL					ITEM TO BE INSPECTED	PROCEDURES CHECK FOR AND HAVE REPAIRED OR ADJUSTED AS NECESSARY	EQUIPMENT IS NOT READY/ AVAILABLE IF:
	B	D	A	W	M			
75	I					Starboard Bow Anchor Windless Hydraulic Power Pack Assembly - continued		
		I				a. Hydraulic Fluid Level Indicator mark.	Check fluid level with hydraulic power pack operating. Fluid level should be at full	Class III leaks.
			I			b. Pressure Gauge	Turn pressure gauge shutoff valve on hydraulic pressure should read 2,900 psi.	
			I			c. Temperature Level Sensor	Check fluid temperature with hydraulic power pack operating. Temperature should be at, or below, 150°F.	
76						Portable Fire-fighting Pump Model PE-250		
		I				Suction Hose	Check hose and hose connections for serviceability.	Connections will not attach properly.
			I			Discharge Hose	Check hose and hose connections for serviceability.	Connections will not attach properly.
			I			Foot valve strainer	Inspect for broken strainer or unserviceable connection.	

Table 2-2. Operator/Crew Preventive Maintenance Checks and Service - CONT

B - Before                      D - During                      A - After                      W - Weekly                      M - Monthly

ITEM NO	INTERVAL					ITEM TO BE INSPECTED	PROCEDURES CHECK FOR AND HAVE REPAIRED OR ADJUSTED AS NECESSARY	EQUIPMENT IS NOT READY/ AVAILABLE IF:		
	B	D	A	W	M					
76	I					Portable Fire-fighting Pump Model PE-250 - continued	<p style="text-align: center;"><b>WARNING</b></p> <p>Do not operate pump in closed area without exhaust hose connected and routed safely to outside fresh air.</p> <p>Check that exhaust hose and gaskets are tight and sealed properly with no leaks.</p>	Exhaust system leaks.		
						Exhaust Hose				
						Fuel Line			Check hose connection for proper direction of fuel flow.	Class III leaks.
						Priming Pump Oil			Check oil level; fill if low.	Low oil level.
						I Spark Plugs			Check condition of spark plugs.	
						I Pump Exterior			Visually inspect pump for damage and condition.	
						I Fuel Tank			Check level of fuel in tank.	
77	I	I				<p style="text-align: center;"><b>NOTE</b></p> <p>Fill gas tank with a mixture of 2 cans of BIA-TC-W oil and 6 gallons of 090 octane gasoline.</p>	Steering gear does not operate smoothly.			
						<p><u>Steering Gear Compartment</u></p>				
						I Steering Gear and Linkage	Inspect the steering gear and linkage for broken or worn parts.			

Table 2-2. Operator/Crew Preventive Maintenance Checks and Service - CONT

B - Before                      D - During                      A - After                      W - Weekly                      M - Monthly

ITEM NO	INTERVAL					ITEM TO BE INSPECTED	PROCEDURES CHECK FOR AND HAVE REPAIRED OR ADJUSTED AS NECESSARY	EQUIPMENT IS NOT READY/ AVAILABLE IF:
	B	D	A	W	M			
78	I					Electro-hydraulic Steering System	Check hydraulic pump unit for leaks.	Class III leaks.
	I					Hydraulic Reservoir maintenance.	Check level of fluid. If fluid level is low, refer to unit	Hydraulic fluid level low.
	I					Hydraulic Pumps	Check pump set for unusual sounds or malfunctioning. Visually inspect pumps for leaks, loose connections and damage. Refer to unit maintenance.	Pumps malfunction. Class III leaks.
	I					Rudder	Check that rudder operates full travel port to starboard.	
79						Compass Repeater		
	I				I	Mounting Bracket	Check for secure mounting to bulkhead. Ensure angle of repeater can be adjusted.	
	I				I	Repeater	Visually inspect for obvious damage (e.g., broken lens, dented housing, etc.).	
80						Steering Gear Local Control Unit		
	I				I	Exterior	Visually inspect exterior for obvious damage.	Damage prevents operation.
		I				Operation	Ensure steering gear system responds properly to the operation of the Local Control Unit.	Unit fails to operate.



Table 2-2. Operator/Crew Preventive Maintenance Checks and Service - CONT

B - Before                      D - During                      A - After                      W - Weekly                      M - Monthly

ITEM NO	INTERVAL					ITEM TO BE INSPECTED	PROCEDURES CHECK FOR AND HAVE REPAIRED OR ADJUST AS NECESSARY	EQUIPMENT IS NOT READY/ AVAILABLE IF:
	B	D	A	W	M			
81						Stern Anchor Winch Hydraulic Pump		
		•				Hydraulic Lines and Fittings	Check hydraulic lines, fittings, and controls for leaks or obvious damage.	
	•					Fluid Level Sight Glass	Fluid level should be at the high mark. Top off as required. Refer to LO 55-1905-223-10.	
		•				Pressure Gauge	Pressure gauge should read 2,900 psi or less.	If reading is above 2900 psi.
		•				Filter Condition Indicator	Differential Pressure Gauge should read less than 10 psi.	If reading is 10 psi or greater.
							<b><u>CAUTION</u></b>	
							Refer low fluid level, no filtration, and excessive hydraulic pressure readings to unit maintenance.	
	•	•	•			Engine Room		
82						Engine Room and Interior Hull		
							<b><u>WARNING</u></b>	
							Open the ventilators to ensure hull compartments and engine room are clear of fuel fumes. Operate the blowers for at least 5 minutes before starting the engine.	
	•	•	•				Inspect the engine room and interior hull for leaks.	Engine room is taking on water or Class III leaks.

Table 2-2. Operator/Crew Preventive Maintenance Checks and Service - CONT

B - Before                      D - During                      A - After                      W - Weekly                      M - Monthly

ITEM NO	INTERVAL					ITEM TO BE INSPECTED	PROCEDURES CHECK FOR AND HAVE REPAIRED OR ADJUST AS NECESSARY	EQUIPMENT IS NOT READY/ AVAILABLE IF:
	B	D	A	W	M			
83		•				Compressed Air Subsystem		Low oil level.
		•			•	Air Compressors	Check oil level. Maintain high and low level marks on bayonet gauge.  <b>CAUTION</b>  Do not overfill or equipment damage may occur.	
		•	•	•	•		Check for oil leaks.	Class III leaks.
		•	•		•		Perform an overall visual inspection and ensure safety guards are in place.	
			•				Check for any unusual noise or vibration.	
		•		•	•	Air Receivers	Check air receivers for moisture accumulation by slightly opening drain valve. Drain until water no longer comes out valve.	
			•		•	Compressed Air Piping System	Check for air leaks  Check safety valves for proper operation.	
					•		Check drop legs and traps in air distribution system for moisture and sediment accumulation.	
			•			AIR RCVR NO 2 PRESS Gauge	Gauge should read 200 psi.	Pressure greater than 200 or less than 180 psi.

Table 2-2. Operator/Crew Preventive Maintenance Checks and Service - CONT

B - Before                      D - During                      A - After                      W - Weekly                      M - Monthly

ITEM NO	INTERVAL					ITEM TO BE INSPECTED	PROCEDURES CHECK FOR AND HAVE REPAIRED OR ADJUST AS NECESSARY	EQUIPMENT IS NOT READY/ AVAILABLE IF:
	B	D	A	W	M			
83						Compressed Air Subsystem - continued		
		•				AIR RCVR NO 1 PRESS Gauge	Gauge should read 200 psi.	Pressure greater than 200 or less than 180 psi.
		•				SYSTEM PRESS Gauge	Gauge should read 125 psi.	Pressure greater than 125 or less than 110 psi.
		•				CPRSR DISCH PRESS Gauge	Gauge should read 200 psi.	Pressure greater than 200 or less than 180 psi.
84		•			•	Propeller and Propeller Shaft (Port)	Check for unusual vibrations.	Shaft is misaligned or bent, propeller blades are bent or damaged or cutlass bearing is excessively worn.
85	•			•	•	Reduction Gear (Port)	Check the reduction gear unit for debris, foreign objects and loose or broken fittings. Refer problems to Unit Maintenance.	Debris, foreign objects remain wedged or lodged in components.
		•				Gearbox	Check for leaks	Class III leaks.

**NOTE**

Inspection of the reduction gear unit should be accomplished prior to startup operational checks of the main propulsion engines.

Table 2-2. Operator/Crew Preventive Maintenance Checks and Service - CONT

B - Before                      D - During                      A - After                      W - Weekly                      M - Monthly

ITEM NO	INTERVAL					ITEM TO BE INSPECTED	PROCEDURES CHECK FOR AND HAVE REPAIRED OR ADJUST AS NECESSARY	EQUIPMENT IS NOT READY/ AVAILABLE IF:
	B	D	A	W	M			
85						Reduction Gear (Port) - continued		
		•				Oil Level	Check that oil level is filled to upper dipstick mark. Add oil if required. Refer to LO 55-1905-223-12.	Low oil level.
		•				Leaks	Inspect reduction gear unit for oil or water leaks	Class III leaks.
		•				Clutch Control	Check that engine speed and clutch control air valve is in neutral position.	
		•				Air Transfer Valve	Check that control air transfer valve is in local position.	
			•			Reduction Gear Cooling Pump	Check gauge for normal readings (30 psi).	Pressure below 28 psi or above 32 psi.
			•			Oil Pressure	Check for oil pressure between 260-280 psi.	Low oil pressure.
			•		Oil Operating Temperature	Check operating temperature. Normal range should be 140° F - 160° F.	Temperature exceeds 160° F on gauge.	
86	•				•	Main Propulsion Engine (Port)	Check the engine for debris, foreign objects and loose or broken fittings Refer problems to unit maintenance.	Debris, foreign objects wedged or lodged in components.
	•	•	•			Engine Accessories and Connections	Inspect engine, fuel injection pumps and cooling pumps for loose or damaged connections or mountings.	
	•					Air Pressure	Check starting air pressure for minimum of 125 psi reading	Low air pressure.

Table 2-2. Operator/Crew Preventive Maintenance Checks and Service - CONT

B - Before                      D - During                      A - After                      W - Weekly                      M - Monthly

ITEM NO	INTERVAL					ITEM TO BE INSPECTED	PROCEDURES CHECK FOR AND HAVE REPAIRED OR ADJUST AS NECESSARY	EQUIPMENT IS NOT READY/ AVAILABLE IF:
	B	D	A	W	M			
86						Main Propulsion Engine (Port) - continued		
		•				Oil Level	Check oil level between the add and full mark on the engine dipstick. Add oil if required. Refer to LO 55-1905-223-12-2.	
		•				Cooling System	Check that engine coolant in expansion tank is at full mark in overhead sight glass.	
		•				Engine Idle Speed	Tachometer should read 725-775 RPM.	Idle speed below 725 or above 775 RPM.
		•				Fuel Oil	Check engine fuel supply.	
			•			Oil Pressure	Check gauge for proper oil pressure (20 to 70 psi).	Oil Pressure less than 20 psi or more than 70 psi.
			•			Cooling System	Check gauge for proper operating coolant temperature (160° F to 203° F).	Temperature more than 180° F.
			•			Lube Oil Temperature	Check gauge for proper operating oil temperature (175° F to 195° F).	Temperature more than 195° F.

Table 2-2. Operator/Crew Preventive Maintenance Checks and Service - CONT

B - Before                      D - During                      A - After                      W - Weekly                      M - Monthly

ITEM NO	INTERVAL					ITEM TO BE INSPECTED	PROCEDURES CHECK FOR AND HAVE REPAIRED OR ADJUST AS NECESSARY	EQUIPMENT IS NOT READY/ AVAILABLE IF:
	B	D	A	W	M			
86						Main Propulsion Engine (Port) - continued		
	•					Start Control	Start engine and note action of starter mechanism, particularly whether mechanism has adequate cranking speed and whether it engages and disengages without unusual noise when the control is operated. Set throttle so that the engine will run at normal warmup speed until prescribed operating temperature is reached. If the oil pressure gauges do not indicate the proper pressure as specified within 30 seconds, stop the engine.	
87						Ship's Service Diesel Generator (Port)	<b><u>WARNING</u></b> Before attempting any maintenance task on the generator set, make sure the generator is off-line. Make sure the engine is shut off and that the starting circuits are disabled to avoid injury to personnel. Make sure that you read the Warning Section at the front of this manual.	
	•	•	•			Engine Accessories and Connections	Inspect engine, generator, fuel injection pumps and cooling pumps for loose or damaged connections or mountings.	
	•					Water Pump Belt	Visually inspect the engine. Look for glazed, loose, frayed, cracked or misaligned belt, refer defects to unit maintenance.	

Table 2-2. Operator/Crew Preventive Maintenance Checks and Service - CONT

B - Before                      D - During                      A - After                      W - Weekly                      M - Monthly

ITEM NO	INTERVAL					ITEM TO BE INSPECTED	PROCEDURES CHECK FOR AND HAVE REPAIRED OR ADJUST AS NECESSARY	EQUIPMENT IS NOT READY/ AVAILABLE IF:
	B	D	A	W	M			
87						Ship's Service Diesel Generator (Port) - continued  • Hoses          • Oil Level          • Coolant Level	<p style="text-align: center;"><b>CAUTION</b></p> Do not bend or deform the hoses during inspection. This can cause the hoses to crack. <ol style="list-style-type: none"> <li>a. Visually inspect all hoses for cracks or cuts and check for any signs of bulging or collapsing.</li> <li>b. Check for loose fittings and clamps, and signs of leakage. Tighten or replace as necessary.</li> <li>c. For replacement, refer to unit maintenance.</li> </ol> <p style="text-align: center;"><b>NOTE</b></p> Allow time for the oil to settle in the pan after engine shutdown. Check the engine oil level. The oil level should be at, or near, the "H" (high) mark on the dipstick. Add oil as necessary. Refer to LO 55-1905-223-12 for oil specifications. <p>Check the coolant level at the expansion tank. It should be 3/4 of the way up sight glass in cold condition. Add coolant at the expansion tank as necessary. Refer to TB 55-1900-207-24 for antifreeze and other additive requirements on make-up coolant.</p>	Class III leaks.

Table 2-2. Operator/Crew Preventive Maintenance Checks and Service - CONT

B - Before                      D - During                      A - After                      W - Weekly                      M - Monthly

ITEM NO	INTERVAL					ITEM TO BE INSPECTED	PROCEDURES CHECK FOR AND HAVE REPAIRED OR ADJUST AS NECESSARY	EQUIPMENT IS NOT READY/ AVAILABLE IF:
	B	D	A	W	M			
87						Ship's Service Diesel Generator (Port) - continued		
		•				Intake Air System	a. Check all air connections for loose clamps or connections, and tighten as required. b. Check all hoses and tubing for cracks, punctures, and tears, and replace as required. c. Check for collapsing hoses or tubing and other damage and replace as required.	
			•			Oil Pressure	Check gauge for normal reading (20-70 psi).	
			•			Engine Idle Speed	Tachometer should read 725-775 RPM.	
			•			Oil Temperature	Check gauge for normal reading (125°-195°F).	
			•			Water Temperature	Check gauge for normal reading (160°-203°F).	
			•			Battery	Check gauge for normal reading (22-28V).	
		•				Throttle (Actuator)	Check for binding, loose fittings, and capscrews that affect the smooth operation of the throttle throughout its range. Refer defects to unit maintenance.	
			•			Exhaust System	a. Check for exhaust leaks. Refer leaks to unit maintenance. b. Check for corrosion and clean as required.	Exhaust system leaks.
		•				Generator	Make sure that air intakes and vents on the generator housing are free from dirt, debris, and other foreign materials.	



Table 2-2. Operator/Crew Preventive Maintenance Checks and Service - CONT

B - Before                      D - During                      A - After                      W - Weekly                      M - Monthly

ITEM NO	INTERVAL					ITEM TO BE INSPECTED	PROCEDURES CHECK FOR AND HAVE REPAIRED OR ADJUST AS NECESSARY	EQUIPMENT IS NOT READY/ AVAILABLE IF:
	B	D	A	W	M			
87						Ship's Service Diesel Generator (Port) - continued  Engine (General)  • Generator (exterior)  • Voltage Regulator regulator.	a. Visually check for air, water, fuel or oil leaks.  b. Tighten any loose connections, fittings or capscrews.  c. If unserviceable, refer to unit maintenance.  <p style="text-align: center;"><b><u>WARNING</u></b></p> Before attempting any maintenance task on the generator set, make sure the generator is off-line. Make sure the engine is shut OFF and that the automatic starting circuits on engine are disabled to avoid injury to personnel.  Clean the exterior of the generator housing and terminal box.  a. Use a rag or soft brush (non-metallic).  b. Vacuum if possible.  Clean dust from electrical terminals and casing on voltage  a. Use a soft bristle nonmetallic brush or vacuum cleaner.  b. Check all leads to regulator for tightness after cleaning.	Class III leaks.

Table 2-2. Operator/Crew Preventive Maintenance Checks and Service - CONT

B - Before                      D - During                      A - After                      W - Weekly                      M - Monthly

ITEM NO	INTERVAL					ITEM TO BE INSPECTED	PROCEDURES CHECK FOR AND HAVE REPAIRED OR ADJUST AS NECESSARY	EQUIPMENT IS NOT READY/ AVAILABLE IF:
	B	D	A	W	M			
87						Ship's Service Diesel Generator (Port) - continued		
		•				Start Control	Start engine and note action of starter mechanism, particularly whether mechanism has adequate cranking speed and whether it engages and disengages without unusual noise when the control is operated. Set throttle so that the engine will run at normal warmup speed until prescribed operating temperature is reached. If the oil pressure gauges do not indicate the proper pressure as specified within 30 seconds, stop the engine.	
88						Fuel Filter/Coalescer		
			•			Differential Pressure	Check differential pressure gauge, reading should be less than 18 psi. Refer to unit maintenance.	Differential pressure above 18 psi.
					•	Exterior	Visually inspect exterior for obvious damage or leaks. Refer to unit maintenance	Class III leakage.
89			•			Fuel Transfer Hand Pump	Visually inspect pump for leaks, loose connections, and damage.	
90			•			Fuel Transfer Pumps	Visually inspect pumps for leaks, loose connections and damage. Check pressure gauges on the side of the fuel filter/coalescer for normal readings (15 inches suction, 30 inches discharge).	

Table 2-2. Operator/Crew Preventive Maintenance Checks and Service - CONT

B - Before                      D - During                      A - After                      W - Weekly                      M - Monthly

ITEM NO	INTERVAL					ITEM TO BE INSPECTED	PROCEDURES CHECK FOR AND HAVE REPAIRED OR ADJUST AS NECESSARY	EQUIPMENT IS NOT READY/ AVAILABLE IF:
	B	D	A	W	M			
91		•			•	Fresh Water Pumps	Visually inspect pumps for leaks, loose connections and damage. Check pressure gauges for normal readings (0-60 psi).	
92		•			•	Dirty Lube Oil Pump	Visually inspect pumps for leaks, loose connections and damage. Check pressure gauges for normal readings (0-30 psi).	
93						Tank Level Indicators		
	•		•		•	Fuel Day Tanks	Check the amount of fuel in the day tanks. Note any evidence of fuel leaks. Add fuel to top off tanks as necessary.	Class III leakage is observed.
94					•	Fire Pumps	Check fire pumps and sea chest valves for proper operation Check gauges for normal readings: (discharge pressure: 10 to 20 psi if overboard, 50 to 90 psi if via firemain, suction pressure: less than 50 psi).	Discharge pressure is greater than 90 psi or suction pressure greater than 50 psi.
95						Batteries	<p style="text-align: center;"><b><u>WARNING</u></b></p> <p>Do not smoke when observing battery electrolyte level. batteries give off fumes that can explode. Electrolyte is an acid and can cause personal injury if it contacts skin or eyes. Wear approved goggles, gloves, and apron.</p>	

Table 2-2. Operator/Crew Preventive Maintenance Checks and Service - CONT

B - Before                      D - During                      A - After                      W - Weekly                      M - Monthly

ITEM NO	INTERVAL					ITEM TO BE INSPECTED	PROCEDURES CHECK FOR AND HAVE REPAIRED OR ADJUST AS NECESSARY	EQUIPMENT IS NOT READY/ AVAILABLE IF:
	B	D	A	W	M			
95						Batteries - continued		
	•		•			Batteries, cables and terminals	Inspect batteries, terminals, connections, cables and vent caps for cleanliness and tightness. Clean or tighten terminal connections as required. Clean battery as required.	
					•	Electrolyte	Check electrolyte level with hydrometer.	
96	•	•	•			Battery Charger	Check battery charger for proper connections to battery. Ammeter should read near 0 for a trickle charge. If the reading is above 3 AMPS, refer to unit maintenance.	
							<b>NOTE</b>	
							A high reading indicates the batteries are weak and are being recharged or that one or more batteries are unserviceable.	
97						Ship's Service Diesel Generator (STBD)	<b><u>WARNING</u></b>	
							Before attempting any maintenance task on the generator set, make sure the genera. Make sure the engine is shut off and that the automatic starting circuits are disabled to avoid injury to personnel. Make sure that you read the Warning Section at the front of this manual.	

Table 2-2. Operator/Crew Preventive Maintenance Checks and Service - CONT

B - Before                      D - During                      A - After                      W - Weekly                      M - Monthly

ITEM NO	INTERVAL					ITEM TO BE INSPECTED	PROCEDURES CHECK FOR AND HAVE REPAIRED OR ADJUST AS NECESSARY	EQUIPMENT IS NOT READY/ AVAILABLE IF:
	B	D	A	W	M			
97						Ship's Service Diesel Generator (STBD) - continued		
	•	•	•			Engine Accessories and Connections	Inspect engine, generator, fuel injection pumps and cooling pumps for loose or damaged connections or mountings.	
	•					Water Pump Belt	Visually inspect the engine,. Look for glazed, loose, frayed, cracked or misaligned belt, refer defects to unit maintenance.	
	•					Hoses	<p style="text-align: center;"><b>CAUTION</b></p> <p>Do not bend or deform the hoses during inspection. This can cause the hoses to crack.</p> <ol style="list-style-type: none"> <li>a. Visually inspect all hoses for cracks or cuts and check for any signs of bulging or collapsing.</li> <li>b. Check for loose fittings and clamps, and signs of leakage. Tighten or replace as necessary.</li> <li>c. For replacement, refer to unit maintenance.</li> </ol>	Class III leaks.
	•					Oil Level	<p style="text-align: center;"><b>NOTE</b></p> <p>Allow time for the oil to settle in the pan after engine shutdown.</p> <p>Check the engine oil level. The oil level should be at, or near, the "H" (high) mark on the dipstick. Add oil as necessary. Refer to LO 55-1905-223-12 for oil specifications.</p>	

Table 2-2. Operator/Crew Preventive Maintenance Checks and Service - CONT

B - Before                      D - During                      A - After                      W - Weekly                      M - Monthly

ITEM NO	INTERVAL					ITEM TO BE INSPECTED	PROCEDURES CHECK FOR AND HAVE REPAIRED OR ADJUST AS NECESSARY	EQUIPMENT IS NOT READY/ AVAILABLE IF:
	B	D	A	W	M			
97						Ship's Service Diesel Generator (STBD) - continued		
		•				Coolant Level	Check the coolant level at the expansion tank. It should be 3/4 of the way up sight glass in cold condition. Add coolant at the expansion tank as necessary. Refer to TB 55-1900-207-24 for antifreeze and other additive requirements on make-up coolant.	
		•				Intake Air System	a. Check all air connections for loose clamps or connections, and tighten as required. b. Check all hoses and tubing for cracks, punctures, and tears, and replace as required. c. Check for collapsing hoses or tubing and other damage and replace as require. Refer defect to unit maintenance.	
			•			Oil Pressure	Check gauge for normal reading (20-70 psi).	
			•			Engine idle Speed	Tachometer should read 725-775 rpm.	
			•		Oil Temperature	Check gauge for normal reading (125° -195° F).		
			•		Water Temperature	Check gauge for normal reading (160° -203° F).		

Table 2-2. Operator/Crew Preventive Maintenance Checks and Service - CONT

B - Before                      D - During                      A - After                      W - Weekly                      M - Monthly

ITEM NO	INTERVAL					ITEM TO BE INSPECTED	PROCEDURES CHECK FOR AND HAVE REPAIRED OR ADJUST AS NECESSARY	EQUIPMENT IS NOT READY/ AVAILABLE IF:
	B	D	A	W	M			
97						Ship's Service Diesel Generator (STBD) - continued		
			•			Battery	Check gauge for normal reading (22-26V).	
		•				Throttle (Actuator)	Check for binding, loose fittings, and capscrews that affect the smooth operation of the throttle throughout its range. Refer defects to unit maintenance.	
		•				Exhaust System	a. Check for exhaust leaks. Refer leaks to unit maintenance.  b. Check for corrosion and clean as required.	Exhaust system leaks.
					•	Soot Trap	Open inspection door, clean out soot.	
		•				Generator	Make sure that air intakes and vents on the generator housing are free from dirt, debris, and other foreign materials.	
		•			Engine (General)	a. Visually check for air water, fuel or oil leaks.  b. Tighten any loose connections, fittings or capscrews.  c. If unserviceable, refer to unit maintenance.	Class III leaks.	





Table 2-2. Operator/Crew Preventive Maintenance Checks and Service - CONT

B - Before                      D - During                      A - After                      W - Weekly                      M - Monthly

ITEM NO	INTERVAL					ITEM TO BE INSPECTED	PROCEDURES CHECK FOR AND HAVE REPAIRED OR ADJUST AS NECESSARY	EQUIPMENT IS NOT READY/ AVAILABLE IF:
	B	D	A	W	M			
97						Ship's Service Diesel Generator (STBD) - continued		
			•			Start Control	Start engine and note action of starter mechanism, particularly whether mechanism has adequate cranking speed and whether it engages and disengages without unusual noise when the control is operated. Set throttle so that the engine will run at normal warmup speed until prescribed operating temperature is reached. If the oil pressure gauges do not indicate the proper pressure as specified within 30 seconds, stop the engine	Unusual noise. Low oil pressure.
98	•	•	•			Bilge/Ballast Pump	Visually inspect pumps for leaks, loose connections and damage. Check bilge/ballast pumps gauges for normal readings (discharge: 20-40 psi, suction: less than 10 psi). If suction is greater than 10 psi, refer to unit maintenance.	Pump is defective or pressure readings are not within range.
99						Auxiliary Sea Water Circulating Pump		
			•			Strainer	Check that sea water strainer is unobstructed,	Strainer is obstructed and can not be cleaned.
				•		Pump	Visually inspect pump for leaks, loose connections and damage. Check gauges for normal readings (15 inches suction, 0-40 inches discharge).	

Table 2-2. Operator/Crew Preventive Maintenance Checks and Service - CONT

B - Before                      D - During                      A - After                      W - Weekly                      M - Monthly

ITEM NO	INTERVAL					ITEM TO BE INSPECTED	PROCEDURES CHECK FOR AND HAVE REPAIRED OR ADJUST AS NECESSARY	EQUIPMENT IS NOT READY/ AVAILABLE IF:
	B	D	A	W	M			
100	•				•	Reduction Gear (STBD)	Check the reduction gear unit for debris, foreign objects and loose or broken fittings. Refer problems to Unit Maintenance.	Debris, foreign objects remain wedged or lodged in components.  Class III leaks. Low oil level. Class III leaks. Pressure below 28 or above 32 psi. Low oil pressure. Temperature exceeds 160° F on gauge.
						Gearbox	Check for leaks	
						Oil Level	Check that oil level is filled to upper dipstick mark. Add oil if required. Refer to LO 55-1905-223-12.	
						Leaks	Inspect reduction gear unit for oil or water leaks.	
						Clutch Control	Check that engine speed and clutch control air valve is in neutral position.	
						Air Transfer Valve	Check that control air transfer valve is in local position.	
						Reduction Gear Cooling Pump	Check pressure gauge for normal readings (30 psi).	
						Oil Pressure	Check for oil pressure between 260-280 psi.	
					Oil Operating Temperature	Check operating temperature. Normal range should be 140° F - 160° F.		

Table 2-2. Operator/Crew Preventive Maintenance Checks and Service - CONT

B - Before                      D - During                      A - After                      W - Weekly                      M - Monthly

ITEM NO	INTERVAL					ITEM TO BE INSPECTED	PROCEDURES CHECK FOR AND HAVE REPAIRED OR ADJUST AS NECESSARY	EQUIPMENT IS NOT READY/ AVAILABLE IF:	
	B	D	A	W	M				
101	•				•	Main Propulsion Engines (STBD)	Check the engine for debris, foreign objects and loose or broken fittings. Refer problems to unit maintenance.	Debris, foreign objects wedged or lodged in components.	
	•	•	•			Engine Accessories and Connections	Inspect engines, fuel injection pumps and cooling pumps for loose or damaged connections or mountings.		
	•					Air Pressure	Check starting air pressure for minimum of 125 psi reading.	Low air pressure.	
	•		•			Oil Level	Check oil level between the add and full mark on the engine dipstick. Add oil if required. Refer to LO 55-1905-223-12-2.		
	•					Cooling System	Check that engine coolant in expansion tank is at full mark in overhead sight glass.	Idle speed below 725 or above 775 RPM.	
	•					Engine Idle Speed	Tachometer should read 725-775 RPM.		
	•					Fuel Oil	Check engine fuel supply.		
		•				Oil Pressure	Check gauge for proper oil pressure (20 to 70 psi).		Oil Pressure less than 20 psi or more than 70 psi.
		•				Cooling System	Check gauge for proper operating coolant temperature (160° F to 203° F).		Temperature more than 180° F.
	•				Lube Oil Temperature	Check gauge for proper operating oil temperature (175° F to 195° F)	Temperature more than 195° F.		

Table 2-2. Operator/Crew Preventive Maintenance Checks and Service - CONT

B - Before                      D - During                      A - After                      W - Weekly                      M - Monthly

ITEM NO	INTERVAL					ITEM TO BE INSPECTED	PROCEDURES CHECK FOR AND HAVE REPAIRED OR ADJUST AS NECESSARY	EQUIPMENT IS NOT READY/ AVAILABLE IF:
	B	D	A	W	M			
101						Main Propulsion Engine (STBD) - continued  Start Control	Start engine and note action of starter mechanism, particularly whether mechanism has adequate cranking speed and whether it engages and disengages without unusual noise when the control is operated. Set throttle so that the engine will run at normal warmup speed until prescribed operating temperature is reached. If the oil pressure gauges do not indicate the proper pressure as specified within 30 seconds, stop the engine.	
102						Propeller and Propeller Shaft (STBD)	Check for unusual vibrations.	Shaft is misaligned or bent, propeller blades are bent or damaged or cutlass bearing is excessively worn.
103						Marine Sanitation Device  Macerator  Discharge Pump  Flow Pump	Check for audible or visual malfunctions.  Check for audible or visual malfunctions.  Check for audible or visual malfunctions.	

Table 2-2. Operator/Crew Preventive Maintenance Checks and Service - CONT

B - Before                      D - During                      A - After                      W - Weekly                      M - Monthly

ITEM NO	INTERVAL					ITEM TO BE INSPECTED	PROCEDURES CHECK FOR AND HAVE REPAIRED OR ADJUST AS NECESSARY	EQUIPMENT IS NOT READY/ AVAILABLE IF:
	B	D	A	W	M			
103						Marine Sanitation Device - continued		
		•				Sludge Return Pump	Check for audible or visual malfunctions.	
		•				Backwash Pressure	Check for proper setting (30 psi) and adjust accordingly.	
		•				Chlorine Storage Container	Check level of sodium hypochlorite solution. Fill as required.	
104		•	•	•	•	STB Reduction Gear Oil Cooling Pumps	Visually inspect pumps for leaks, loose connections, and damage. Check gauges for normal readings (30 psi).	Pumps are defective.
105		•	•	•	•	Prelube Oil Pumps	Visually inspect pumps for leaks, loose connections, and damage. Check gauges for normal readings (30 psi).	Pumps are defective.
106						Oil Water Separator		
		•				Exterior	Visually inspect unit for leaks, loose connections, and damage.	Class III leakage.
		•				1ST STAGE Gauge	Gauge should read less than 20 psi.	Gauge reads 20 psi or higher.
		•				2ND STAGE Gauge	Gauge should read less than 10 psi.	Gauge reads 10 psi or higher.
		•				3RD STAGE Gauge	Gauge should read less than 10 psi.	Gauge reads 10 psi or higher.
		•				OUTLET Gauge	Gauge should read less than 40 psi.	Gauge reads 40 psi or higher.

Table 2-2. Operator/Crew Preventive Maintenance Checks and Service - CONT

B - Before                      D - During                      A - After                      W - Weekly                      M - Monthly

ITEM NO	INTERVAL					ITEM TO BE INSPECTED	PROCEDURES CHECK FOR AND HAVE REPAIRED OR ADJUST AS NECESSARY	EQUIPMENT IS NOT READY/ AVAILABLE IF:
	B	D	A	W	M			
106						Oil Water Separator - continued		
		•				Differential Pressure Gauge	Gauge should read less than 5 psi.	Gauge reads 5 psi or higher.
107	•	•			•	Purifier Preheater	Inspect the purifier preheater for secure mounting and leaks.	Class III leakage.
108	•	•	•			Lubricating Oil Purifier	Inspect the lubricating oil purifier for secure mountings and tight frame covers.	Class III leakage.
109		•	•		•	Lubricating Oil Transfer Hand Pump	Visually inspect pump for leaks, loose connections, and damage.	Pump is defective.
110	•					Fresh Water Makers		
	•					Pump, High Pressure	Check oil. Refer to LO 55-1905-223-12,	
		•				Low Pressure Gauge	Should read on positive side of gauge.	
		•				Quality Low Light	Check that quality low light is OFF. If light is ON, all water is being diverted to brine discharge	Potable water is not being produced as indicated by the Quality Low light staying lite.
111		•	•		•	Gear Oil Cooling Pumps	Visually inspect pumps for leaks, loose connections, and damage. Check gauges for normal readings (30 psi).	Pumps are defective.

Table 2-2. Operator/Crew Preventive Maintenance Checks and Service - CONT

B - Before                      D - During                      A - After                      W - Weekly                      M - Monthly

ITEM NO	INTERVAL					ITEM TO BE INSPECTED	PROCEDURES CHECK FOR AND HAVE REPAIRED OR ADJUST AS NECESSARY	EQUIPMENT IS NOT READY/ AVAILABLE IF:
	B	D	A	W	M			
112		•				<p><u>Engine Room Operating Station</u></p> <p>Marine Sanitation Device Monitor Panel</p>	<p>Ensure POWER ON indicator is lit. Ensure HIGH LEVEL WARNING indicator is not lit. Observe pump indicator lights. Lights should cycle through, staying lit for approximately 15 sec.</p>	<p>HIGH LEVEL WARNING indicator or any PUMP light stays lit.</p>
113	•				•	<p>Engine Room Console</p>	<p>Inspect console for cleanliness, clean as required. Look for any loose, missing, or broken switches or controls, gauges, indicator lights, or obvious damage.</p>	
	•				•	CRT-MCHRY SYSTEMS MONITOR	Clean screen with window cleaner.	
	•				•	ENGINE ORDER TELEGRAPH	Press DIMMER pushbutton, ensure intensity of lamps are adjustable.	
114	•	•			•	<p>Engine Operating Station - Air Handling Unit</p>	<p>Check unit for leaks and unusual noises.</p>	<p>Unusual noises.</p>
	•				•		<p>Check exterior of unit for wear, damage and corrosion.</p>	
	•				•	Air Grille	<p>Check air grille for dust or dirt buildup and restrictions.</p>	
	•				•	Filter	<p>Check filter for dust, lint and dirt buildup.</p>	

Table 2-2. Operator/Crew Preventive Maintenance Checks and Service - CONT

B - Before                      D - During                      A - After                      W - Weekly                      M - Monthly

ITEM NO	INTERVAL					ITEM TO BE INSPECTED	PROCEDURES CHECK FOR AND HAVE REPAIRED OR ADJUST AS NECESSARY	EQUIPMENT IS NOT READY/ AVAILABLE IF:
	B	D	A	W	M			
115	•				•	Main Switchboard	Visually inspect exterior of switchboard for damaged or missing circuit breakers, meters, controls or lights.	Any part is missing, or meters are unserviceable.
						<u>Machine Shop and Storeroom</u>		
116					•	Bench Grinder		Safety equipment not available.
	•		•			Associated Equipment	Check that face shields and dust masks are available and serviceable.	
	•					Wheel	Visually check that grinding wheels are serviceable.	
	•					Tool Rest	Visually check that tool rest is in correct position and is securely mounted.	
	•					Spark Guard	Visually check that spark guard is clear, undamaged and securely mounted.	
117	•		•		•	Arc Welder	Check air channels and remote control terminal strip for dust or dirt buildup. If cleaning is required, refer to unit maintenance.	
118	•				•	Wet/Dry Vacuum Commercial	Visually check vacuum unit for signs of wear, dirt buildup, damage and corrosion.	
	•						Check accessories kit for worn and broken attachments.	
	•						Check extension wands for signs of wear, damage and corrosion.	
	•						Check hose for wear and serviceability.	



Table 2-2. Operator/Crew Preventive Maintenance Checks and Service - CONT

B - Before                      D - During                      A - After                      W - Weekly                      M - Monthly

ITEM NO	INTERVAL					ITEM TO BE INSPECTED	PROCEDURES CHECK FOR AND HAVE REPAIRED OR ADJUST AS NECESSARY	EQUIPMENT IS NOT READY/ AVAILABLE IF:
	B	D	A	W	M			
119						<ul style="list-style-type: none"> <li>Tools, Spare Parts and Equipment</li> </ul>	<p>Check against craft stowage list to see that all tools, spare parts and equipment belonging to the craft are on hand, clean, serviceable and properly mounted or stowed.</p> <p style="text-align: center;"><b>NOTE</b></p> <p>Before performing preventive maintenance checks and services, review appropriate procedures to ensure that necessary tools, spare parts and equipment are available.</p>	
120	•	•	•			<p><u>Engine Room (Forward) and Tunnel</u></p> <ul style="list-style-type: none"> <li>Machinery Space Ventilation</li> </ul>	<p>Check operation of the air supply fans and the air exhaust fans.</p>	<p>Air supply or air exhaust fans inoperable.</p>
	•	•				<ul style="list-style-type: none"> <li>Ventilation Motor Control Center</li> </ul>	<p>Visually inspect exterior of Motor Control Center for damaged or missing circuit breakers, meters, controls or lights.</p>	<p>Any part is missing, or meters are unserviceable.</p>
121						<ul style="list-style-type: none"> <li>Auxiliary Motor Control Center</li> </ul>	<p>Visually inspect exterior of Motor Control Center for damaged or missing circuit breakers, meters, controls or lights.</p>	<p>Any part is missing, or meters are unserviceable.</p>
122						<p>Hydraulic Fluid Storage Tank</p> <ul style="list-style-type: none"> <li>Manual Hand Pump</li> </ul>	<p>Visually inspect pump for leaks, loose connections, and damage.</p>	<p>Class III leakage.</p>

Table 2-2. Operator/Crew Preventive Maintenance Checks and Service - CONT

B - Before                      D - During                      A - After                      W - Weekly                      M - Monthly

ITEM NO	INTERVAL					ITEM TO BE INSPECTED	PROCEDURES CHECK FOR AND HAVE REPAIRED OR ADJUST AS NECESSARY	EQUIPMENT IS NOT READY/ AVAILABLE IF:
	B	D	A	W	M			
122						Hydraulic Fluid Storage Tank - continued		
						<ul style="list-style-type: none"> <li>• Tank</li> </ul>	Visually inspect tank for leaks.	Class III leakage.
						<ul style="list-style-type: none"> <li>• <u>Bowthruster Compartment</u></li> </ul>		
123						Bowthruster Fuel Oil Day Tank	Visually inspect tank for leaks.	Class III leakage.
124						Batteries		
							<b><u>WARNING</u></b>	
							Do not smoke when observing battery electrolyte level. Batteries give off fumes that can explode. Electrolyte is an acid and can cause personal injury if it contacts skin or eyes. Wear approved goggles, gloves, and apron.	
	•		•	•		Batteries, cables and terminals	Inspect batteries, terminals, connections, cables and vent caps for cleanliness and tightness. Clean or tighten terminal connections as required. Clean battery as required.	
						<ul style="list-style-type: none"> <li>• Electrolyte</li> </ul>	Check electrolyte level with hydrometer.	
125	•	•	•			<ul style="list-style-type: none"> <li>• Battery Charger</li> </ul>	Check battery charger for proper connections to battery. Ammeter should read near 0 for a trickle charge. If the reading is above 3 AMPS, refer to unit maintenance.	

Table 2-2. Operator/Crew Preventive Maintenance Checks and Service - CONT

B - Before                      D - During                      A - After                      W - Weekly                      M - Monthly

ITEM NO	INTERVAL					ITEM TO BE INSPECTED	PROCEDURES CHECK FOR AND HAVE REPAIRED OR ADJUST AS NECESSARY	EQUIPMENT IS NOT READY/ AVAILABLE IF:
	B	D	A	W	M			
125						Battery Charger - continued	<p style="text-align: center;"><b>NOTE</b></p> <p>A high reading indicates the batteries are weak and are being recharged or that one or more batteries are unserviceable.</p>	
126						• Chain Locker Hand Pump	Visually inspect pump for leaks, loose connections, and damage.	
127	•					Port Anchor Windlass Hydraulic Power Unit	Check hydraulic power unit for debris, foreign objects, and loose or broken fittings.	
		•				a. Hydraulic Fluid Level Indicator	Check fluid level with hydraulic power unit operating. Fluid level should be at full mark.	Class III leaks.
		•				b. Pressure Gauge	Turn pressure gauge shutoff valve on hydraulic pressure should read 2,900 psi.	
		•				c. Temperature Level Sensor	Check fluid temperature with hydraulic power pack operating. Temperature should be at, or below, 150° F.	
128	•					Bowthruster Engine	Check the engine for debris, foreign objects and loose or broken fittings. Refer to TM 55-1905-223-24-5.	Debris, foreign objects wedged or lodged in components and loose fittings on equipment.

Table 2-2. Operator/Crew Preventive Maintenance Checks and Service - CONT

B - Before                      D - During                      A - After                      W - Weekly                      M - Monthly

ITEM NO	INTERVAL					ITEM TO BE INSPECTED	PROCEDURES CHECK FOR AND HAVE REPAIRED OR ADJUST AS NECESSARY	EQUIPMENT IS NOT READY/ AVAILABLE IF:
	B	D	A	W	M			
128						Bowthruster Engine - continued		
		•				Block heater	Check block heater for proper operation by placing hand near but not on block. Warmth should be felt.	Block is not warm.
		•				Oil Level	Maintain oil level between the add and full marks on the engine stopped side of the dipstick. Add oil if required. Refer to LO 55-1905-223-12.	
		•				Fuel System	Check for fuel system leaks.	Class III leaks.
		•				Fuel Oil Day Tank	Check fuel oil day tank. Sight glass should be full.	
		•				Gauges	Check the condition of all gauges for broken lenses, damaged frames and brackets.	
			•			Oil Pressure	Check gauge for proper oil pressure (35 to 70 psi).	Low oil pressure.
			•			Fuel Pressure	Check gauge for proper operating fuel pressure NORMAL (green) range.	Fuel pressure not within NORMAL (green) range.
			•			Cooling System	Check cooling water expansion tank level on tank sightglass indicator.	
							<b>NOTE</b>	
							Tank should be slightly less than full to allow for expansion.	

Table 2-2. Operator/Crew Preventive Maintenance Checks and Service – CONT

B – Before      D – During      A – After      W – Weekly      M- Monthly

ITEM NO.	INTERVAL					ITEM TO BE INSPECTED	PROCEDURES CHECK FOR AND HAVE REPAIRED OR ADJUSTED AS NECESSARY	EQUIPMENT IS NOT READY/ AVAILABLE IF:
	B	D	A	W	M			
128		•				Bowthruster Engine – continued	Check gauge for proper operating coolant temperature (170° to 195°F).	Temperature more than 195°F.
		•				Leaks	Check for fuel, oil, coolant leaks and unusual noises.	Class III leakage and/or unusual noises.
			•			Switches	Check that all switches are in proper positions. Refer to Table 2-1, FIGURE 2-115.	
		•				Tachometer	Tachometer should read 650 rpm at idle.	
129		•				Bowthruster Waterjet		
		•				Lube Oil Tank	Check, then replenish oil. Refer to LO 55-1905-223-12.	
		•				Hydraulic Oil Tank	Check, then replenish oil. Refer to LO 55-1905-223-12.	

**NOTE**

**If oil level is below the window of the gauge glass, add oil until level reaches the mid-point of the window.**

Table 2-2. Operator/Crew Preventive Maintenance Checks and Service – CONT

B – Before      D – During      A – After      W – Weekly      M- Monthly

ITEM NO.	INTERVAL					ITEM TO BE INSPECTED	PROCEDURES CHECK FOR AND HAVE REPAIRED OR ADJUSTED AS NECESSARY	EQUIPMENT IS NOT READY/ AVAILABLE IF:
	B	D	A	W	M			
129						Bowthruster Waterjet – continued	<p style="text-align: center;"><b>NOTE</b></p> <p>The hydraulic system can be operated safely at fluid levels anywhere between the HIGH and LOW mark on the sight gauge/thermometer. Low fluid level can cause high operating temperature. When the level reaches the LOW mark or when fluid temperature exceeds 150°F, add fluid until level reaches HIGH mark.</p>	
130	•					Emergency Fire Pump	<p>Visually inspect pump for leaks, loose connections and damage.</p> <p>Check for any unusual noise or vibration.</p> <p>Monitor pressure gauge. Pressure should be 105 psi, maintain by speed of bowthruster engine.</p>	Required pressure cannot be maintained or pressure too high.
131		•				FM-200 System	Ref. TM 55-1905-243-24&P, FM-200, Fire Fighting System for LCU-2000.	
132		•				Water Wash-down System (WWS)	Ref. TM 55-1905-243-24&P, FM-200, Fire Fighting System for LCU-2000.	

## Section III. OPERATION UNDER USUAL CONDITIONS

Para.		Page
2-3	General.....	2-284
2-4	Preparation for Use.....	2-284
2-5	Before You Operate This Equipment.....	2-284
2-6	Power Generation.....	2-290
2-7	Fire Main and Foam System .....	2-305
2-8	Compressed Piping Air System.....	2-324
2-9	Life Support System .....	2-331
2-10	Gyrocompass System.....	2-357
2-11	Air Start Main Generator .....	2-368.4
2-12	Main Propulsion System .....	2-387
2-13	Steering System .....	2-424
2-14	Bowthruster System.....	2-433
2-15	HALON 1301 Fire Suppression System.....	2-443
2-16	Bilge/Ballast Piping System Operation.....	2-447
2-17	Lube Oil Purification and Transfer Piping System Operation.....	2-454
2-18	Fuel Oil Filter Transfer, and Supply Piping System .....	2-471
2-19	Oil-Water Separator Piping System .....	2-484
2-20	Hydraulic Oil Supply Piping System .....	2-492
2-21	Bow Anchor Windlass, and Bow Ramp Winch, and Bow Ramp Operations...	2-492
2-22	Stern Anchor Winch Operation .....	2-510
2-23	Engine Order Telegraph (EOT).....	2-521
2-24	Sound Powered Telephone System.....	2-525
2-25	Intercom (LS-519A) Operation .....	2-530
2-26	Bench Grinder.....	2-534
2-27	Electric Welding Machine .....	2-536
2-28	Rotary Window Wipers .....	2-538
2-29	Watertight Hatch Operation .....	2-541
2-30	500 Watt Xenon Searchlight.....	2-541
2-31	Portable Fire Pump.....	2-544
2-32	Commissary Equipment.....	2-551
2-33	Life Rafts and Workboat/Workboat Crane.....	2-576
2-34	Shore Connections.....	2-579
2-35	Equipment Condition Prior to Getting Underway .....	2-589
2-36	Main Engine Shutdown.....	2-589
2-37	Gyro Compass MK 27 Mod 1 Shutdown.....	2-589
2-38	Fresh Water Piping System Shutdown.....	2-589
2-39	Auxiliary Machinery Motor Control Center Shutdown.....	2-601
2-40	Compressed Air System Shutdown.....	2-604
2-41	Emergency Generator and Switchboard Shutdown.....	2-604
2-42	Ship's Service Diesel Generator Shutdown.....	2-604
2-43	Fire Main and Foam Piping System Shutdown.....	2-604
2-44	Final Shutdown.....	2-635
2-45	Rigging LCU to Tow.....	2-635

2-3. **General.** The following information is provided for the guidance of personnel responsible for operation of the LCU. It is essential that operator/crew know how to perform every operation of which the equipment is capable and to coordinate the basic motions to perform the specific tasks for which the LCU was designed. Since nearly every job presents a different problem, the operator may have to vary given procedures to fit the individual job;.

2-4. **Preparation for Use.**

- a. On Emergency Switchboard (FIGURE 2-87) set all equipment circuit breakers to ON position.
- b. On Emergency Generator Diesel Control Panel (FIGURE 2-88), set RUN/OFF/AUTO switch (1) to OFF position.
- c. On Main Switchboard (FIGURE 2-89), set all circuit breakers to OFF position except EMERGENCY SWITCHBOARD TIE BREAKER circuit breaker (4) set to ON position.

**NOTE**

Circuit breakers for equipment vital to the LCU operation are located on the emergency switchboard bus. They are electrically powered from the Main Switchboard Bus Tie. These systems operate on normal ship power and/or emergency power.

- d. On Auxiliary Machinery Motor Control Center (FIGURE 2-90), set all circuit breakers to OFF position.
- e. On Engine Room Ventilation Motor Control Center (FIGURE 2-91) set all circuit breakers to OFF position.

2-5. **Before You Operate This Equipment.** The following operating procedures are sequential to allow the vessel master to bring the LCU from a dead in the water mode to a full power underway condition. Instructions are provided to systematically bring each subsystem/equipment into operation. Each subsystem/equipment will have the operator/crew before operating (b) preventive maintenance checks and services (PMCS) performed as it is prepared for operation. See Table 2-2 in Section II of this chapter. Shutdown procedures take the vessel from full power to dead in the water.



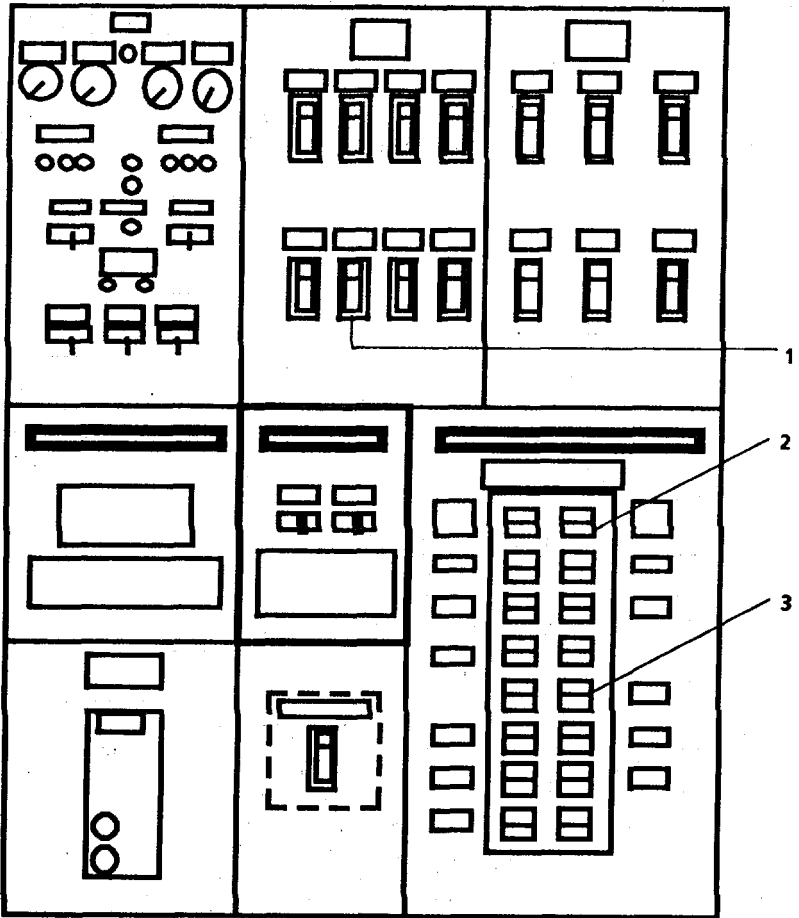

**LEGEND**

- 1. EMG SWBD 120V XFMRs
- 2. WHL/HSE EMG LTG PNL
- 3. EMG. LIGHT BELOW MN DECK

FIGURE 2-87. Emergency Switchboard.

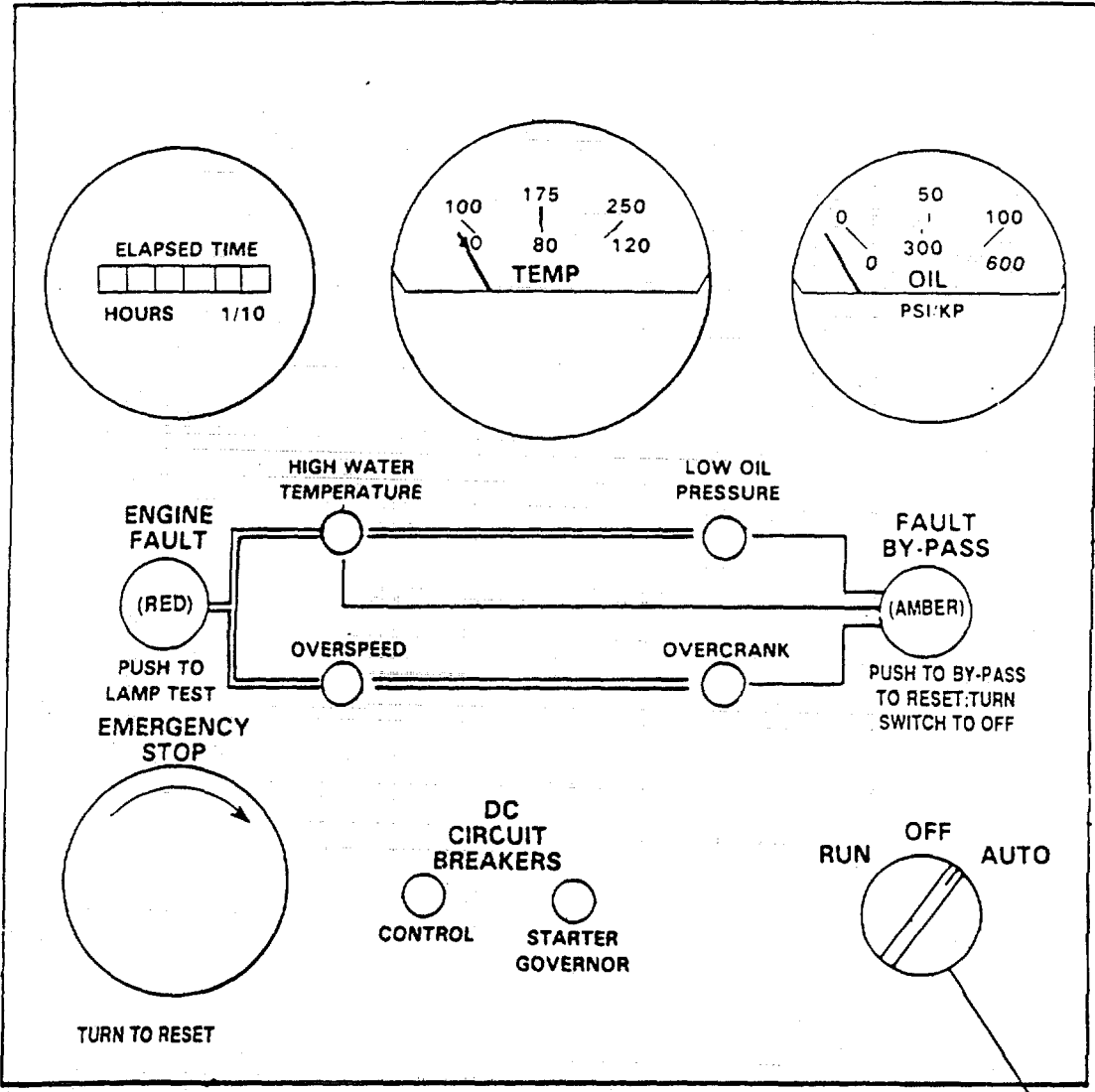

**LEGEND**  
1. RUN-OFF AUTO SWITCH

FIGURE 2-88. Emergency Generator Diesel Control Panel.

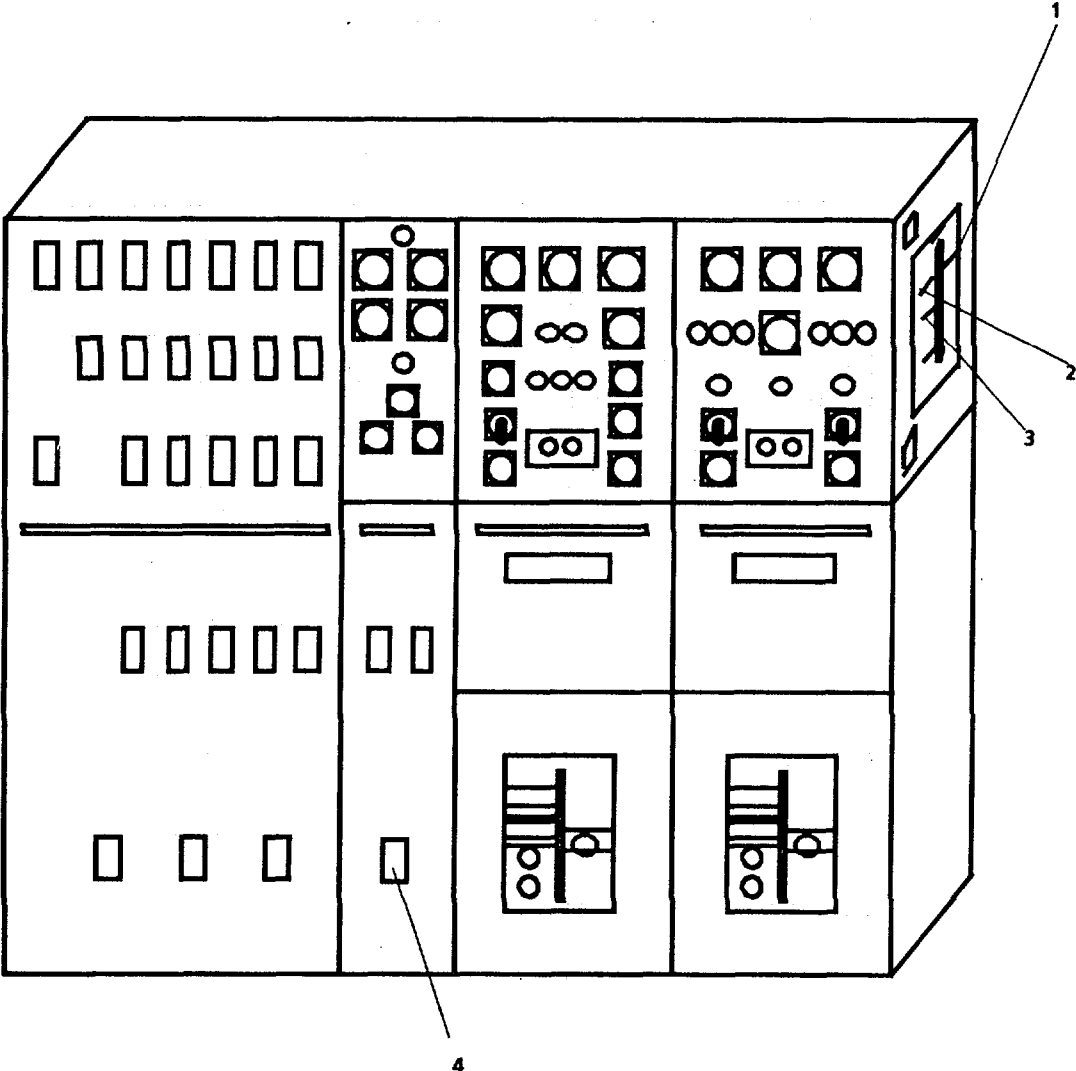

**LEGEND**

- 1. WHEELHOUSE LIGHTING PANEL
- 2. ENG ROOM LIGHTING PANEL
- 3. MN DECK LIGHTING PANEL
- 4. EMERGENCY SWITCHBOARD TIE BREAKER CIRCUIT BREAKER

FIGURE 2-89. Main Switchboard.

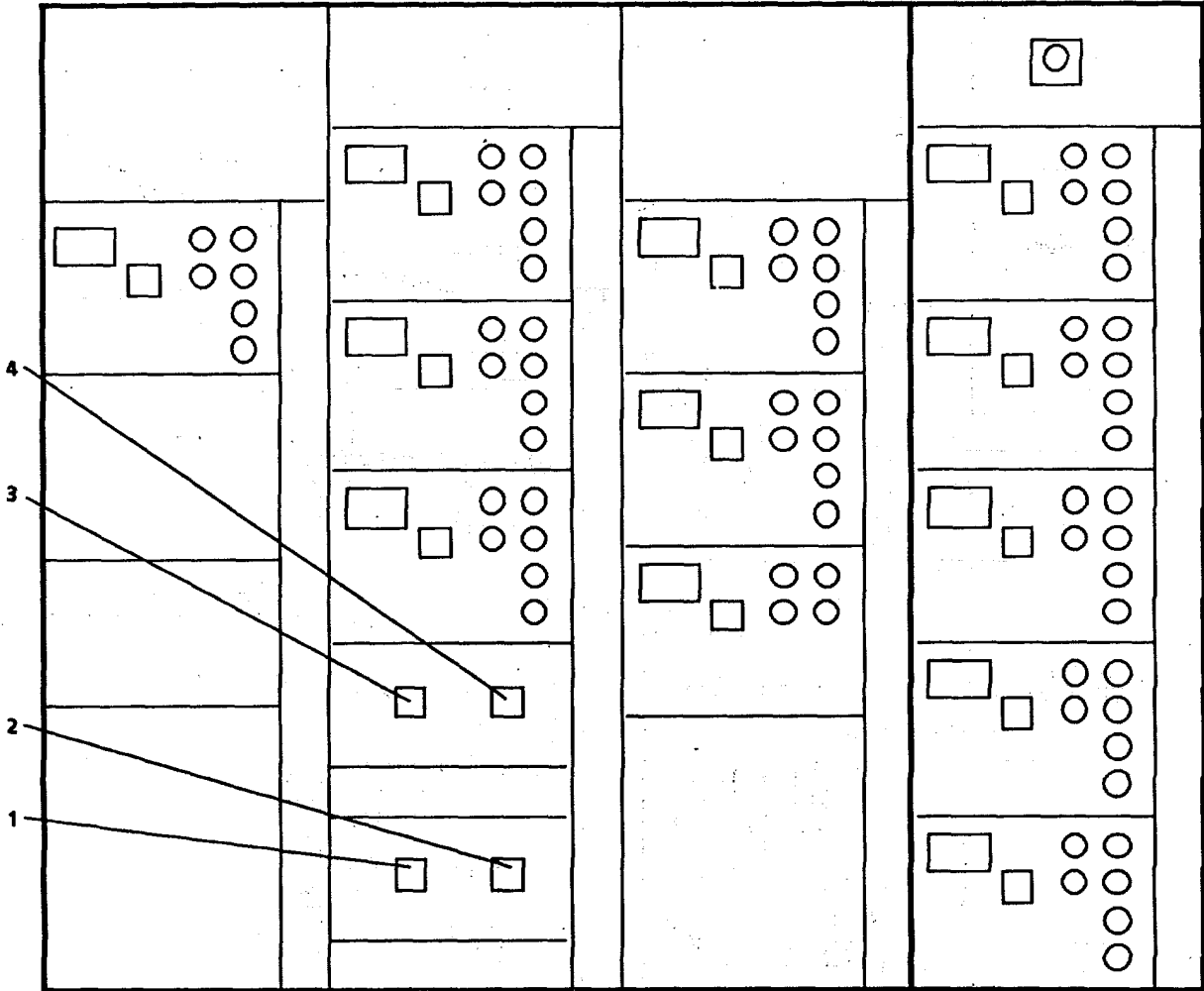

**LEGEND**

- 1. STBD SSDG JACKET WATER HEATER NO. 1
- 2. PORT SSDG JACKET WATER HEATER NO. 2
- 3. STBD MAIN ENGINE JACKET WATER HEATER NO. 1
- 4. PORT MAIN ENGINE JACKET WATER HEATER NO. 2

FIGURE 2-90. Auxiliary Machinery Motor Control Center.

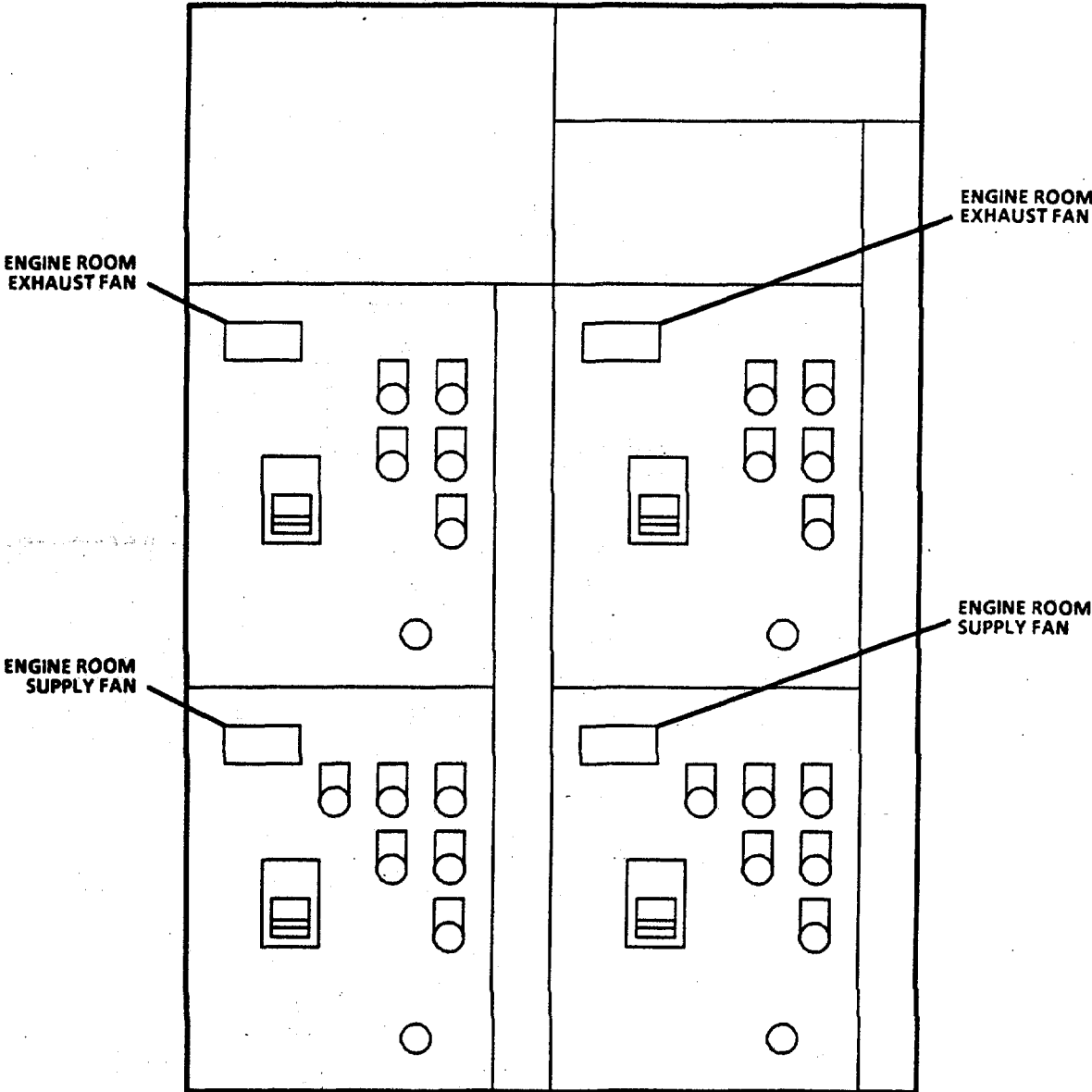

FIGURE 2-91. Engine Room Ventilation Motor Control Center

**2-6. Power Generation.**

- a. On Emergency Switchboard (FIGURE 2-87), set EMG SWBD 120V XFMRS (1), WHL/HSE EMG LTG PNL (2), and EMERG LIGHT BELOW MN DECK (3) circuit breakers to ON position.
  - (1) On Wheelhouse Emergency Lighting Panel (EL102), set circuit breaker 6 to ON position.
- b. On Main Switchboard (FIGURE 2-89), set WHEELHOUSE LIGHTING PANEL (1), ENG ROOM LIGHTING PANEL (2) and MN DECK LIGHTING PANEL (3) circuit breakers to ON position.
  - (1) On Engine Room Lighting Panel L102, set circuit breakers 2, 3, 6, 7, 11 and 14 to ON position.
  - (2) On Wheelhouse Lighting Panel L105, set circuit breaker 2 to ON position.
  - (3) On Main Deck Lighting Panel L104, set circuit breakers 1, 2, 4, 5, 6, 13, and 16 to ON position.
- c. On Auxiliary Machinery Motor Control Center (FIGURE 2-90).
  - (1) Set STBD SSDG JACKET WATER HEATER NO. 1 circuit breaker (1) to ON position.
  - (2) Set PORT SSDG JACKET WATER HEATER NO. 2 circuit breaker (2) to ON position.
  - (3) Set STBD MAIN ENGINE JACKET WATER HEATER NO. 1 circuit breaker (3) to ON position.
  - (4) Set PORT MAIN ENGINE JACKET WATER HEATER NO. 2 circuit breaker (4) to ON position.
- d. Align Fuel Oil Filter, Transfer, and Supply Piping System (FIGURE 2-92; Sheet 1) to the starboard ship service diesel generator (electric start) as follows:
  - (1) Close all valves in Fuel Oil Filter, Transfer, and Supply Piping System.
  - (2) Open FO-33, DAY TK F-12S SUPPLY TO STBD MN ENG & SSDG (17).
  - (3) Open FO-39, RETURN FR STBD SSDG TO DAY TK F-12S (15).
  - (4) Open FO-31, SUPPLY TO STBD SSDG (9).
- e. Align SSDG Fresh Water Cooling System (FIGURE 2-93) as follows:
  - (1) Close all valves in the Fresh Water Cooling System.
  - (2) Open FWC-15, EXP TK-SSDG STBD (7).

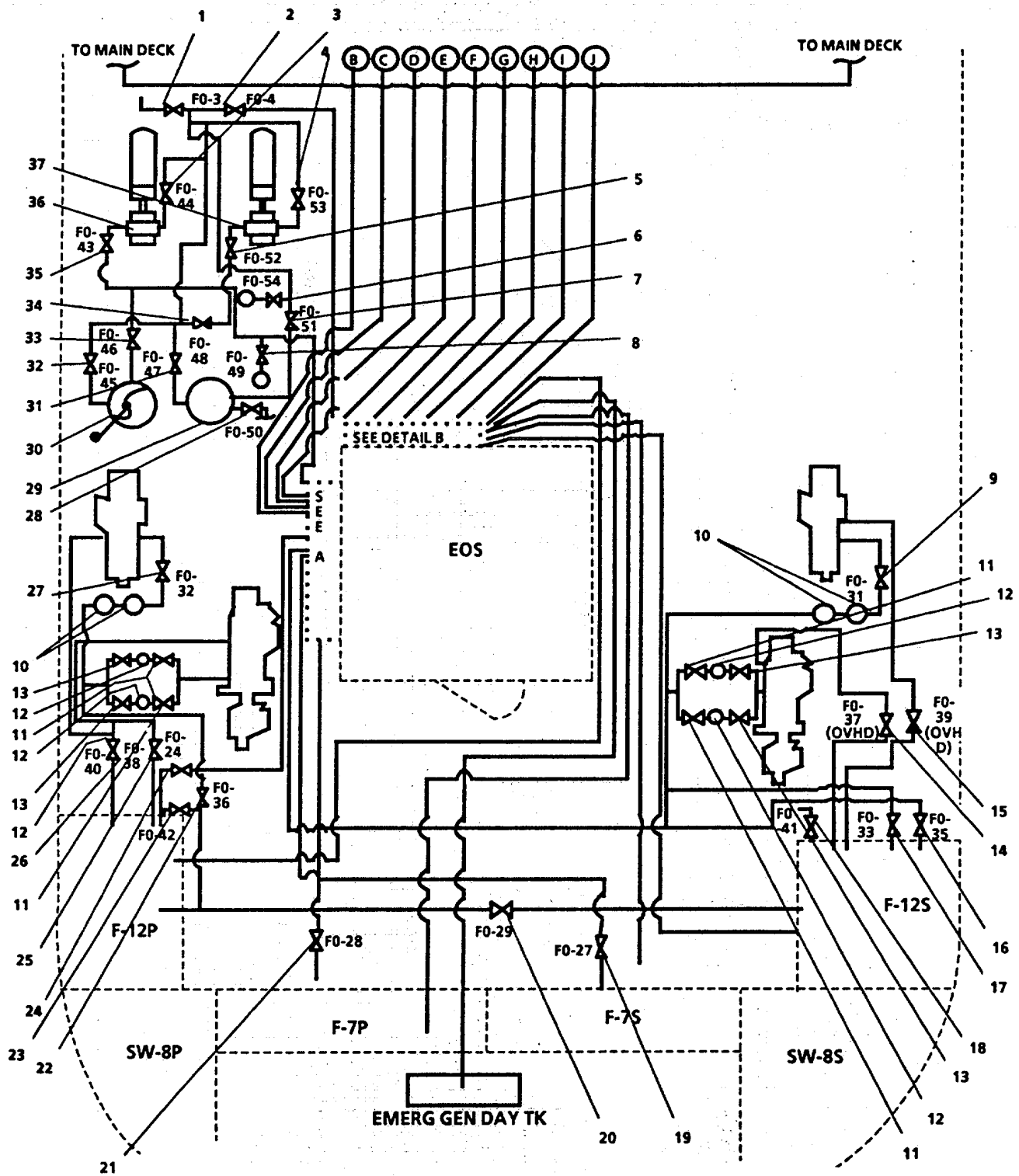

FIGURE 2-92. Fuel Oil Filter, Transfer, and Supply Piping System (Sheet 1 of 6).

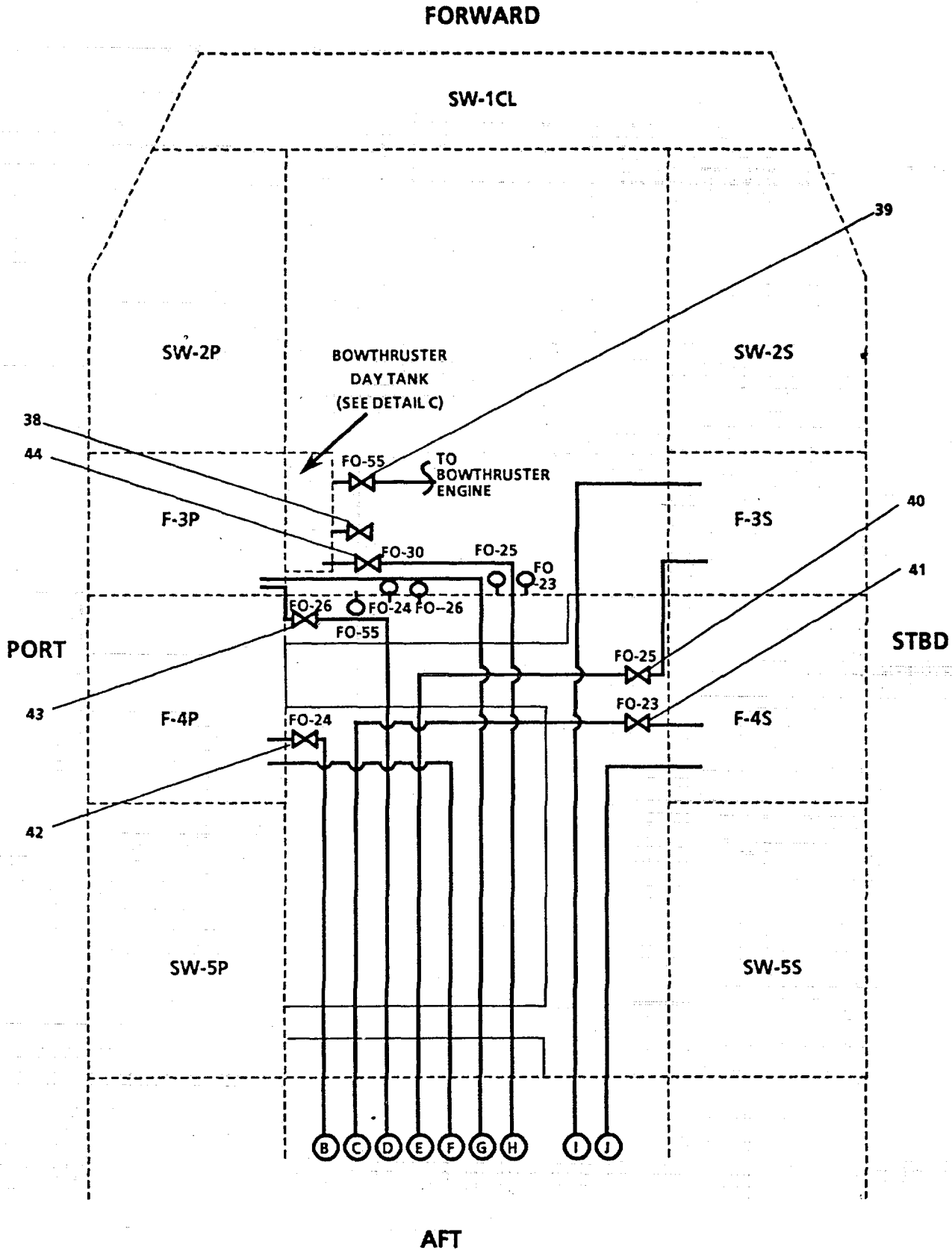

FIGURE 2-92. Fuel Oil Filter, Transfer, and Supply Piping System (Sheet 2 of 6).



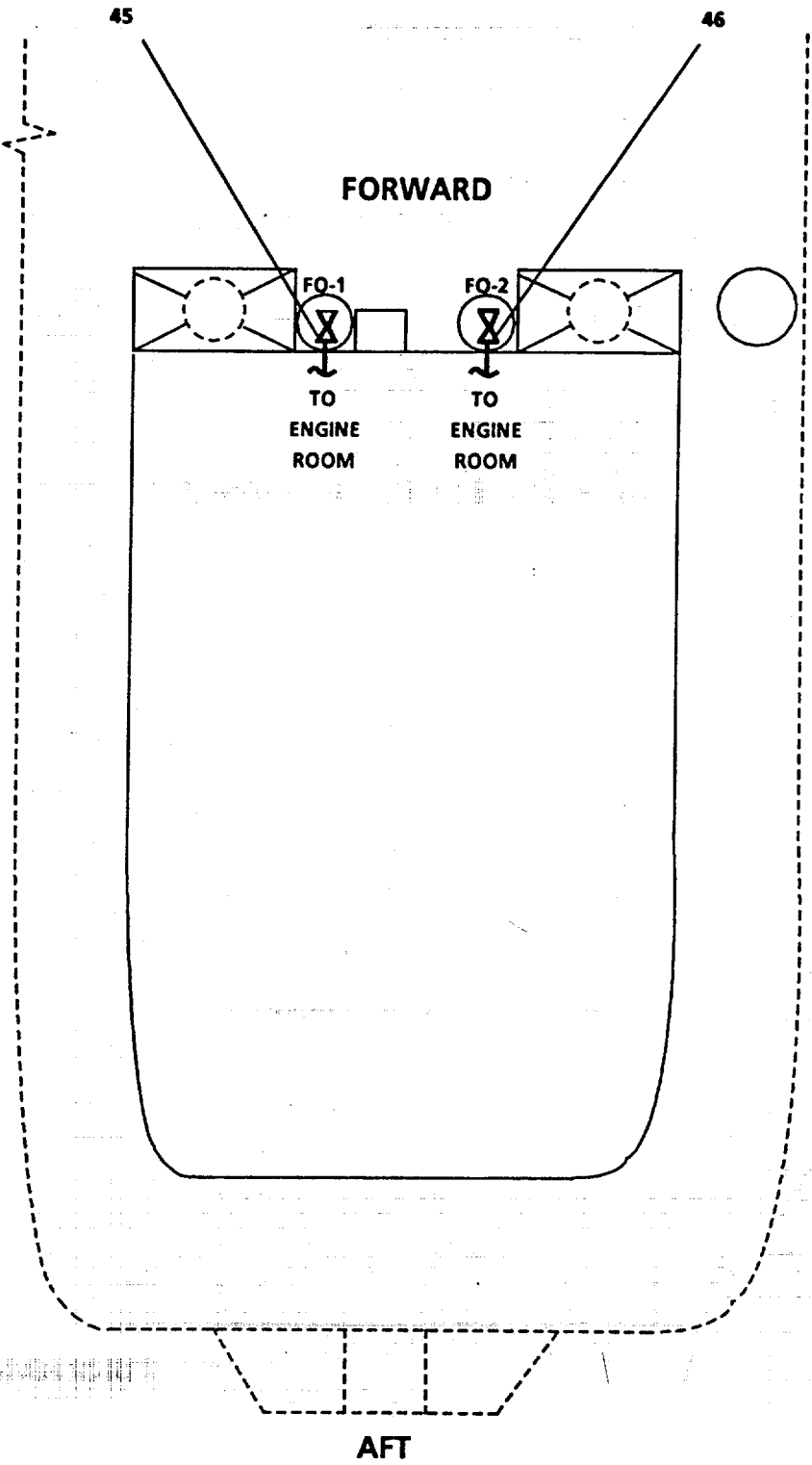
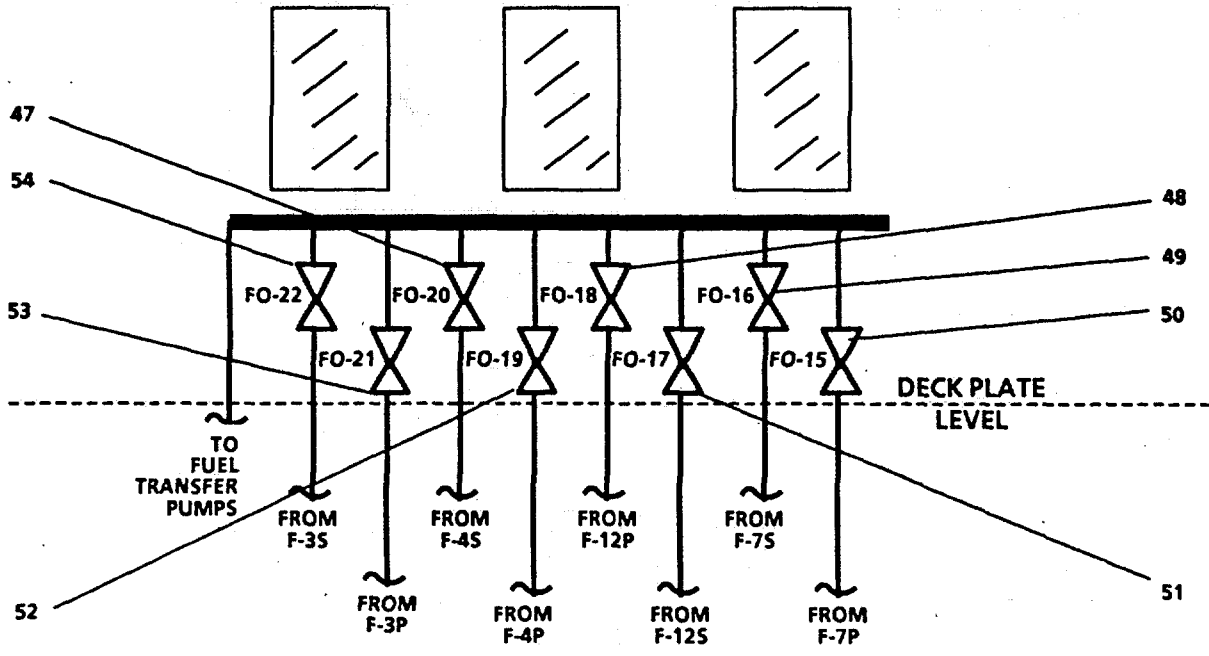

FIGURE 2-92. Fuel Oil Filter, Transfer, and Supply Piping System (Sheet 3 of 6).

**DETAIL A  
PORT EXTERIOR BULKHEAD  
OF EOS (FORWARD)**



**DETAIL B  
FORWARD EXTERIOR BULKHEAD  
OF EOS (PORT)**

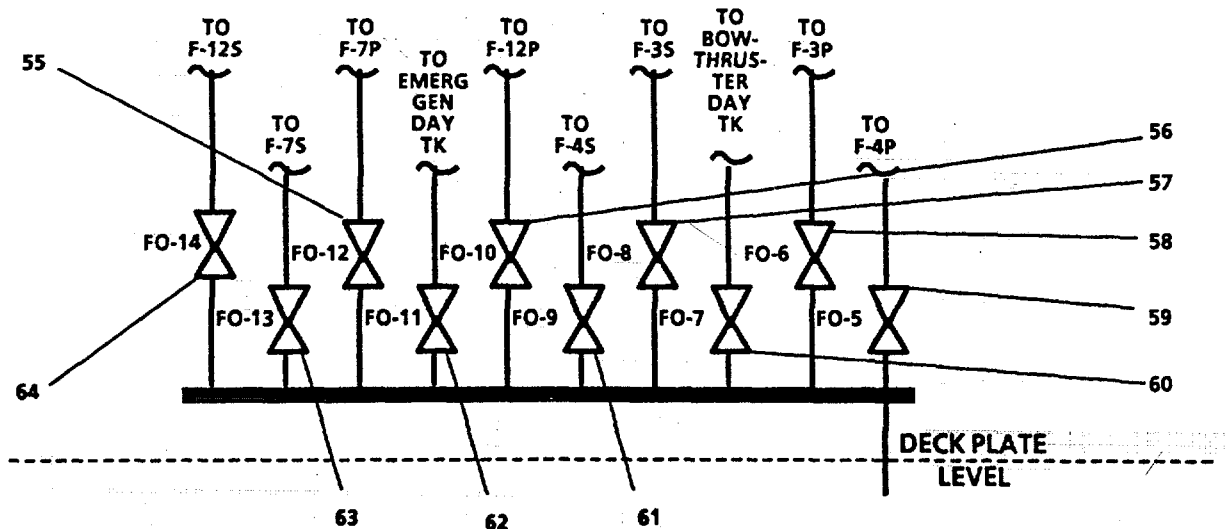

FIGURE 2-92. Fuel Oil Filter, Transfer, and Supply Piping System (Sheet 4 of 6).

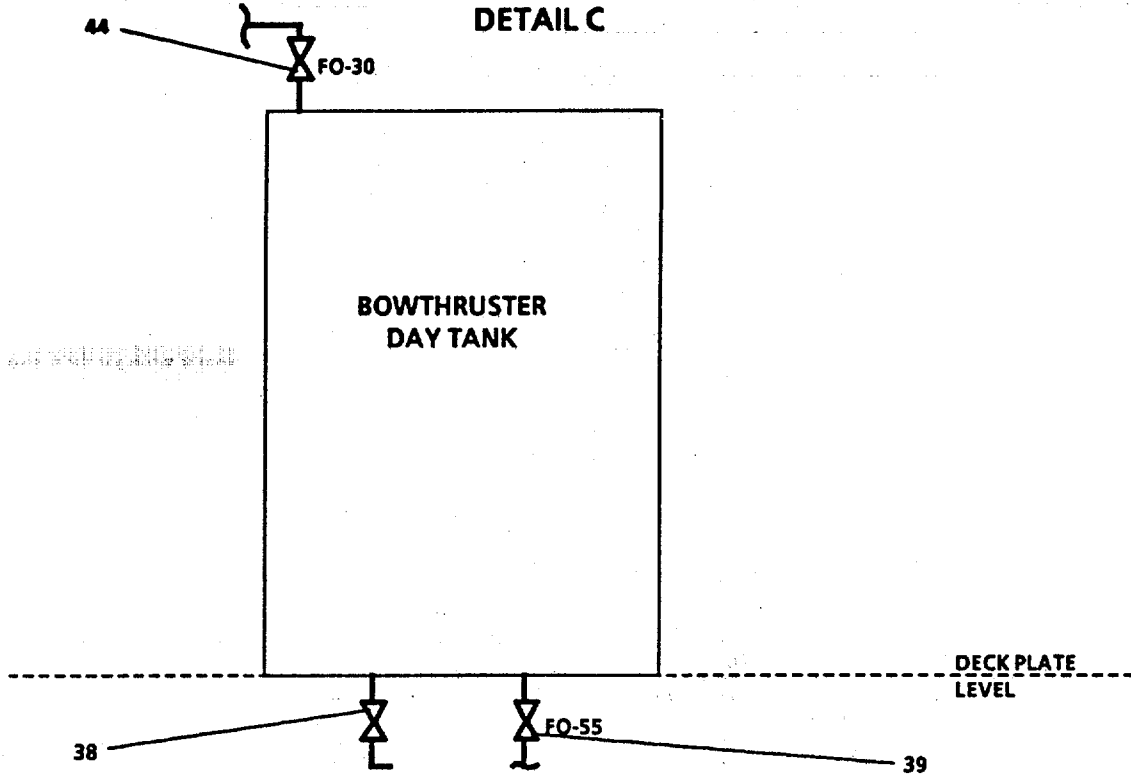
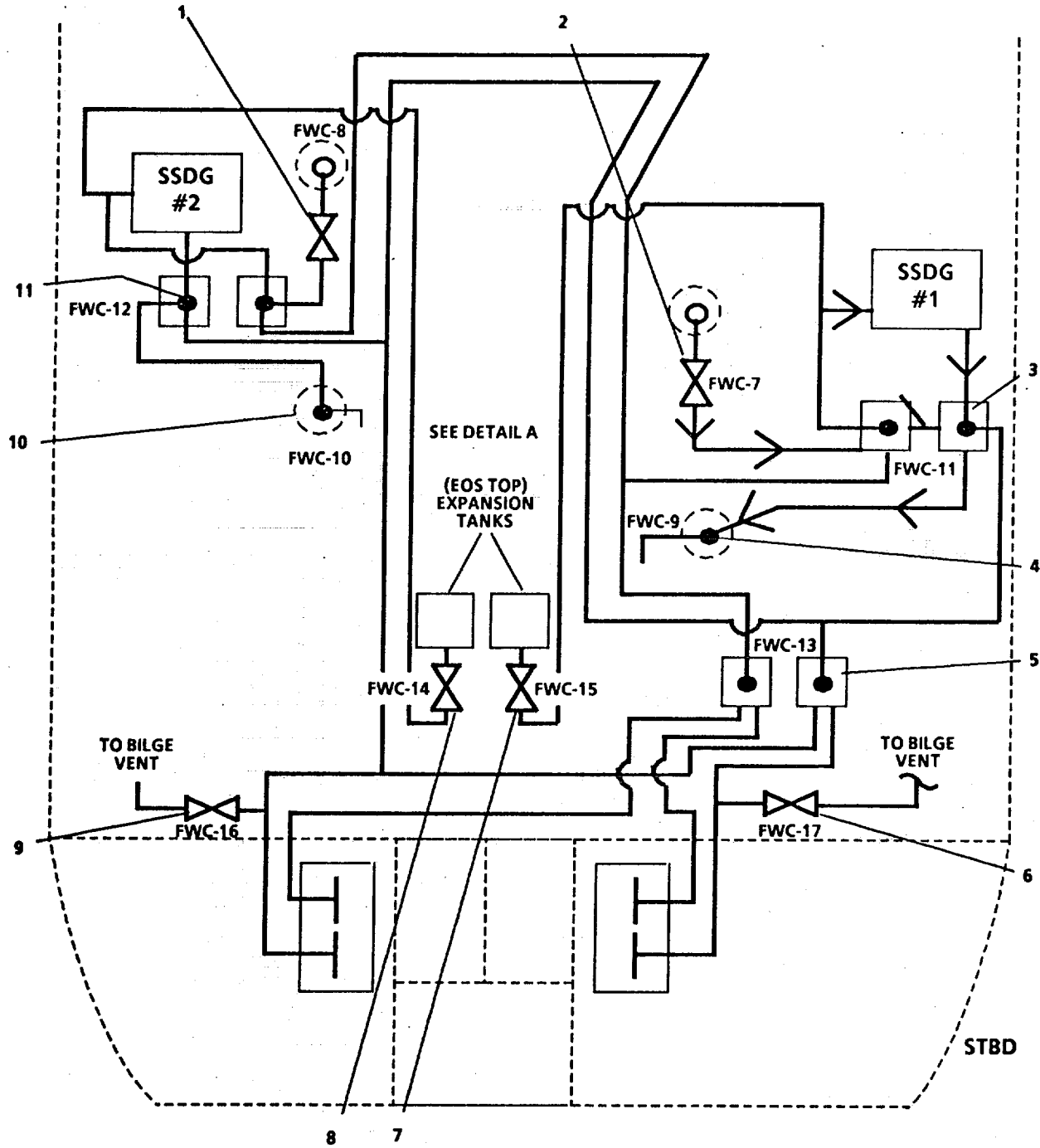

FIGURE 2-92. Fuel Oil Filter, Transfer, and Supply Piping System (Sheet 5 of 6).

1. FO-3, ISLN-FILL/DISCH STATIONS
2. FO-4, SUPPY TO FO SUPPLY MANF
3. FO-44, DISCH -NO. 2 XFR PUMP
4. FO-53, DISCH- NO. 1 XFR PUMP
5. FO-52, SUCT-NO. I XFR PUMP
6. FO-54, PUMP DISCH PRESS GAGE
7. FO-51, FILTER/SEPARATOR OUTLET
8. FO-49, PUMP SUCT PRESS GAGE
9. FO-31, SUPPLY TO STBD SSDG
10. SSDG FUEL FILTERS
11. MN ENG FILTER DISCH VALVE
12. MN ENG FILTER
13. MN ENG FILTER INLET VALVE
14. FO-37, RETURN FR STBD MN ENG TO DAY TK F-12S
15. FO-39, RETURN FR STBD.SSDG TO DAY TK F-12S
16. FO-35, SUCT FR DAY TK F-12S
17. FO-33, DAY TK F-12S SUPPLY TO STBD MN ENG & SSDG
18. FO-41, DRAIN FR DAY TK F-I 2S
19. FO-27, SUCT FR TK F-7S
20. FO-29, CROSS CONN - DAY TKS
21. FO-28, SUCT FR TK F-7P
22. FO-36, DAY TK F-12P SUPPLY TO PORT MN ENG & SSDG
23. FO-42, DRAIN FR DAY TK F-i2P
24. FO-34, SUCT FRDAYTK F-12P
25. FO-38, RETURN FR PORT MN ENG TO DAY TK F-12P
26. FO-0, RETURN FR PORT SSDG TO DAY TK F-12P
27. FO-32, SUPPLY TO PORT SSDG
28. FO-50, DRAIN TO SLUDGE TK
29. FUEL FILTER/COALESCER
30. FUELTRANSFER HAND PUMP
31. FO-47, FILTER/SEPARATOR INLET
32. FO-45, HAND PUMP DISCH
33. FO-46, HAND PUMP SUCT
34. FO-48, BY-PASS FILTER/SEPARATOR
35. FO-43, SUCT-NO.2 XFR PUMP
36. FO.2 XFR PUMP
37. NO. 1 XFR PUMP
38. BOW THRUSTER DAY TK DRAIN
39. FO-55, SUPPLY TOBOW THRUSTER ENGINE
40. FO-25, SUCT FR TK F-3S
41. FO-23, SUCT FR TK F-4S
42. FO-24, SUCT FR TK F-4P
43. FO-26, SUCT FR TK F-3P
44. FO-30, SUPPLY TO BOW THRUSTER DAY TK
45. FO-1, FUEL OIL FILLIDISCH
46. FO-2, FUEL OIL FILL/DISCH
47. FO-20, SUCT FR TK F-4S
48. FO-18, SUCT FR TK F-12P
49. FO-16, SUCT FR TK F-7S
50. FO-15, SUCT FR TK F-7P
51. FO-17, SUCT FR TK F-12S
52. FO-19, SUCT FR TK F-4P
53. FO-21, SUCT FR TK F-3P
54. FO-22, SUCT FR TK F-3S
55. FO-12, SUPPLY TO TK F-7P
56. FO-10, SUPPLY TO DAY TK F-12P
57. FO-8. SUPPLY TO TK F-3S
58. FO-6, SUPPLY TO TK F-3P
59. FO-5, SUPPLY TO TK F-4P
60. FO-7, SUPPLY TOBOW THRUSTER DAYTK
61. FO-9, SUPPLY TO TK F-4S
62. FO-11, SUPPY TO EMER GEN DAY TK
63. FO-13, SUPPY TO TK F-7S
64. FO-14, SUPPY TO TK F-12S

FIGURE 2-92. Fuel Oil Filter, Transfer, and Supply Piping System (Sheet 6 of 6).

SSDG #1 TO STBD KEEL COOLER



LEGEND

- |   |  |
|---|--|
| 1. FWC-8, KEEL CLR OUTLET                           | 7. FWC-15, EXP TK-SSDG STBD                      |
| 2. FWC-7, KEEL CLR OUTLET                           | 8. FWC-14, EXP TK-SSDG PORT                      |
| 3. FWC-11, KEEL CLR/SSDG-STBD CLG MODE              | 9. FWC-16, VENT KEEL CLR IN SWP-8P               |
| 4. FWC-9, KEEL CLR INLET                            | 10. FWC-10, KEEL CLR INLET                       |
| 5. FWC-13, KEEL CLR SELECTOR BLST TK SW-8P OR SW-8S | 11. FWC-12, KEEL CLR/SSDG-PORT CLG MODE SELECTOR |
| 6. FWC-17, VENT KEEL CLR IN SW-8S                   |  |

FIGURE 2-93. SSDG Fresh Water Piping System (Sheet 1 of 2).

DETAIL A

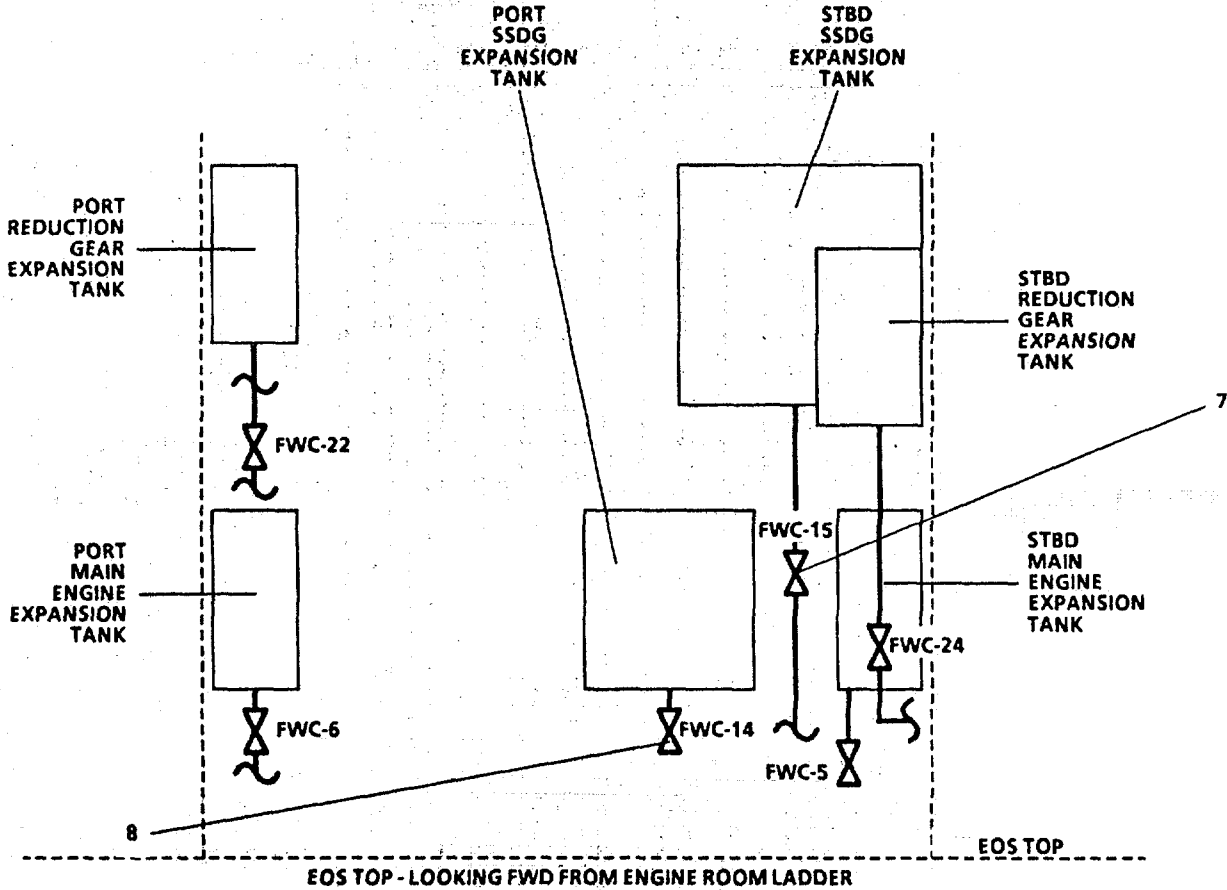

LEGEND:

- 7. FWC-15, EXP TK-SSDG STBD
- 9. FWC-14, EXP TK-SSDG PORT

FIGURE 2-93. SSDG Fresh Water Piping System (Sheet 2 of 2).

- (3) Position FWC-II, KEEL CLR/SSDG-STBD, CLG MODE SELECTOR (3) to port position.

**NOTE**

With FWC-11 positioned to port, two valves are operated, one suction and one discharge, since both valves operate on the same control arm.

- (4) Open FWC-9, KEEL CLR INLET (4).  
(5) Open FWC-7, KEEL CLR OUTLET (2).

**NOTE**

If the LCU is in a beached condition, the Ship Service Diesel Generator will require its cooling system to be cooled from Sea Water (SW) Tank #8, either Port or Starboard. The following alignment will be used.

- (6) Position FWC-13, KEEL CLR SELECTOR, BLST TK SW-8P OR SW-8S (5) to AFT position.

**NOTE**

With FWC-13 positioned to FWD/AFT, two valves are operated, one suction and one discharge, since both valves operate on the same control arm. These valves direct the SSDG cooling water to cooling coils in SW #8 ballast tanks, either Port (arm to FWD) or STBD (arm to aft).

- f. On Ship Service Diesel Generator Control Panel (FIGURE 2-94), set IDLE/RUN switch (6) to IDLE position.  
g. Set START-RUN-OFF switch (4) to RUN position to ensure 24 Vdc power is available to start and then pull up to START position.  
h. Press CRANK pushbutton (3).

**CAUTION**

If engine fails to start within 30 seconds, release CRANK pushbutton (3). Wait 2 minutes to allow starter motor to cool before using it again.

- i. Allow engine to idle for 3 to 5 minutes until WATER TEMP gauge (2) needle starts to rise.

**CAUTION**

If OIL PRESS gauge (1) needle does not rise to 45 psi within 15 seconds, stop engine or equipment damage could result. Notify unit maintenance.

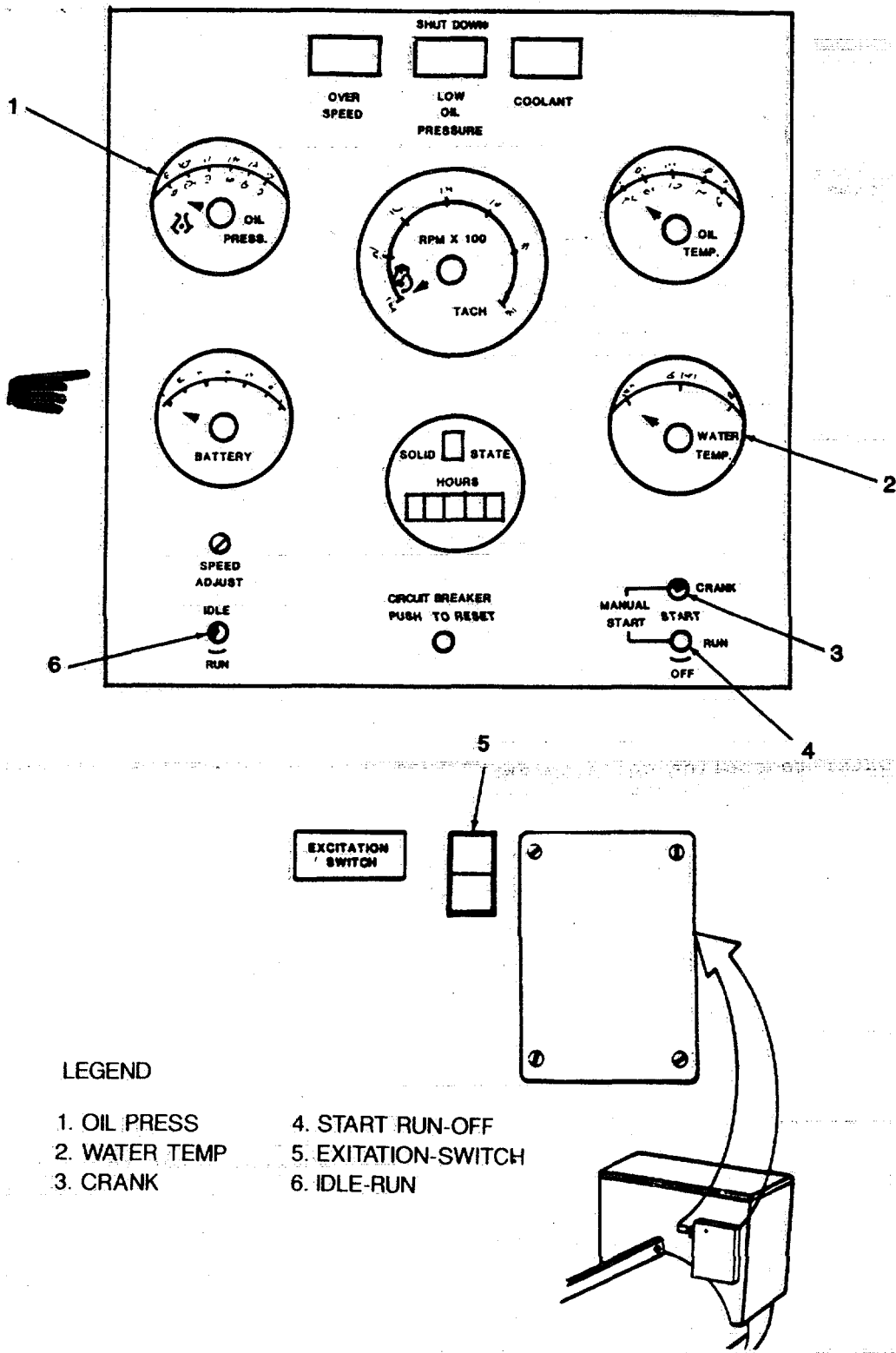

LEGEND

- 1. OIL PRESS
- 2. WATER TEMP
- 3. CRANK
- 4. START RUN-OFF
- 5. EXITATION-SWITCH
- 6. IDLE-RUN

FIGURE 2-94. Ship Service Diesel Generator Control Panel



**NOTE**

Generator/diesel engines, except main engines, on the LCU have an Automatic Low Oil Pressure Shutdown System. This system will activate at a low oil pressure condition and shut engine down.

**NOTE**

If engine speed is not between 600 and 650 rpm, notify unit maintenance.

- j. Set IDLE-RUN switch (5) to RUN position.
- k. Set EXCITATION SWITCH (6) to ON position.
- l. On Main Switchboard (FIGURE 2-95), set AUTO OFF MANUAL switch (3) to AUTO position.
- m. On Main Switchboard (FIGURE 2-95), turn GENERATOR 1 SPEED CONTROL (4) to read 60 Hertz on the GENERATOR 1 FREQUENCY METER (6).
- n. On Main Switchboard (FIGURE 2-95), set VOLTMETER SWITCH (10) to phase of generator No. 1.
- o. Adjust GENERATOR 1 VOLTAGE ADJUST RHEOSTAT (7) to read 240 volts on GENERATOR 1 VOLTMETER (5).
- p. Adjust GENERATOR 1 SPEED CONTROL (4) to read 60 Hertz on GENERATOR 1 FREQUENCY METER (6).

**NOTE**

If generator is started with AUTO OFF MANUAL switch (3) in MANUAL position, voltage adjustment is made by EXCITATION CONTROL (9).

- q. On Main Switchboard (FIGURE 2-95), set GENERATOR 1 CIRCUIT BREAKER as follows:
  - (1) Turn CIRCUIT BREAKER LOADING ARM (11) 90 degrees.
  - (2) Return CIRCUIT BREAKER LOADING ARM (11) to the vertical position.
  - (3) On Main Switchboard (FIGURE 2-95), set SHORE POWER SWITCH (17) to NORMAL position.
  - (4) On Main Switchboard (FIGURE 2-95), push CLOSE pushbutton (12) to release circuit breaker spring and place GENERATOR 1 on line.
  - (5) On Emergency Switchboard (FIGURE 2-96), set MAIN SWBD BUS TIE circuit breaker (1) to ON position.
  - (6) On Main Switchboard (FIGURE 2-95), set circuit breakers (13, 14, and 15) to ON position.

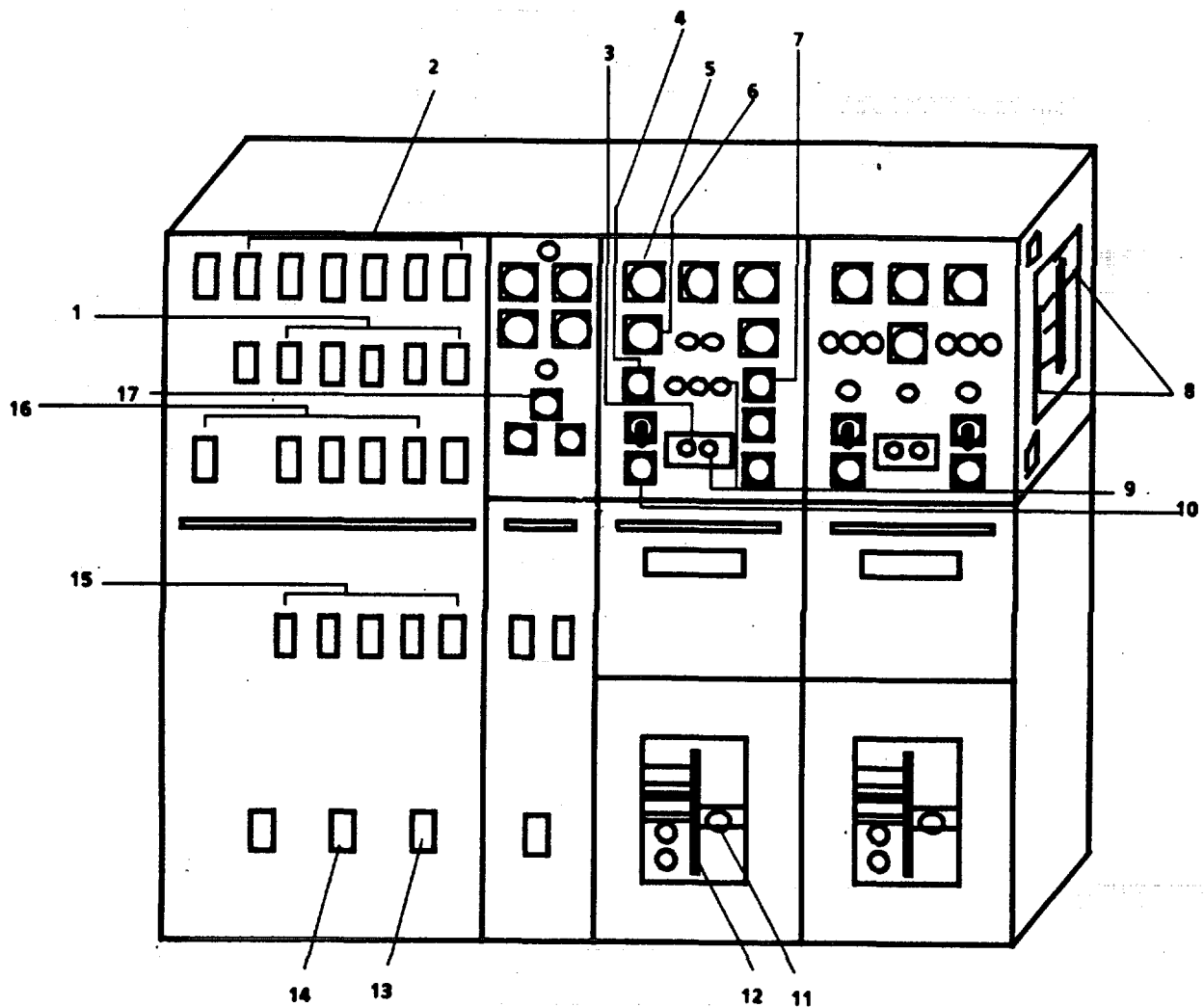

**LEGEND**

- |   |   |
|---|---|
| <p>1. FIRE PUMP 2 CIRCUIT BREAKER<br/>STERN ANCHOR WINCH CIRCUIT BREAKER<br/>F.W. PUMP 2 CIRCUIT BREAKER<br/>HOT WATER HTR CIRCUIT BREAKER</p> <p>2. FIRE PUMP 1 CIRCUIT BREAKER<br/>BOAT DAVIT CIRCUIT BREAKER<br/>F.W. PUMP 1 CIRCUIT BREAKER<br/>ENG. RM. CONT. A/C UNIT CIRCUIT BREAKER<br/>PILOT HOUSE A/C UNIT CIRCUIT BREAKER<br/>ACCODATIONS A/C UNIT CIRCUIT BREAKER<br/>MISC. MCHRY POWER PANEL CIRCUIT BREAKER</p> <p>3. AUTO OFF MANUAL SWITCH</p> <p>4. GENERATOR 1 SPEED CONTROL</p> <p>5. GENERATOR 1 VOLTMETER</p> <p>6. GENERATOR 1 FREQUENCY METER</p> <p>7. GENERATOR 1 VOLTAGE ADJUST RHEOSTAT</p> <p>8. WHEELHOUSE LIGHTING PANEL<br/>GALLEY 120V PANEL CIRCUIT BREAKER<br/>ENG. ROOM LIGHTING PANEL CIRCUIT</p> | <p>9. EXCITATION CONTROL</p> <p>10. VOLTMETER SWITCH</p> <p>11. CIRCUIT BREAKER LOADING ARM</p> <p>12. CLOSE</p> <p>13. GALLEY POWER PANEL CIRCUIT BREAKER</p> <p>14. S/S SWBD 120V XFMRS CIRCUIT BREAKER</p> <p>15. FWD DECK MCHRY MCC CIRCUIT BREAKER<br/>BILGE/BALLAST PUMP CIRCUIT BREAKER<br/>AUX. MCHRY MCC CIRCUIT BREAKER<br/>BOW RAMP WINCH CIRCUIT BREAKER</p> <p>16. MCHRY SPACES VENT PANEL CIRCUIT BREAKER<br/>ENG. ROOM VENT MCC CIRCUIT BREAKER<br/>FWD HEATER POWER PANEL CIRCUIT BREAKER<br/>MCHRY SPACES HTR PWR PNEL CIRCUIT</p> <p>17. SHORE POWER SWITCH</p> |
|---|---|

FIGURE 2-95. Main Switchboard.

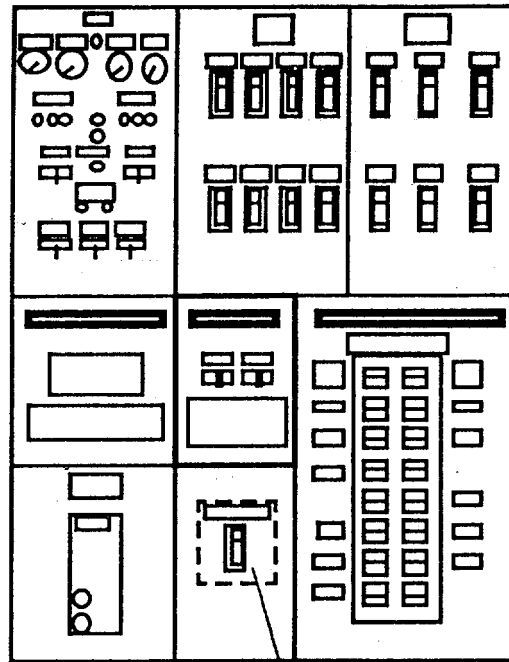

**LEGEND**  
1. MAIN SWBD BUS TIE

*FIGURE 2-96. Emergency Switchboard.*

- (7) On Main Switchboard (FIGURE 2-95), set circuit breaker (8) to ON position.
- (8) On Lighting Panel L102, set circuit breaker 13 to ON position.
- (9) At Power Panel P203, set all circuit breakers to ON position.
- (10) At Power Panel P204, set all circuit breakers to ON position.
- (11) On Main Switchboard (FIGURE 2-95), set circuit breakers (1, 2, and 16) to ON position.
- (12) In Engine Room Operating Station, open Engine Efficiency Panel (FIGURE 2-97), set MAIN POWER switch (1) to UP position, set FIELD POWER switch (4) to DOWN position, and PRIMARY-BACKUP switch (3) to PRIMARY position.

**CAUTION**

Ensure FIELD POWER switch (4) is OFF (DOWN) until after monitor system performs its self check. This allows the battery to be charged.

- (13) Set FIELD POWER switch (4) to UP position.
- (14) On printed circuit board (FIGURE 2-97), set RUN-BACKUP switch (2) to BACKUP position.

**NOTE**

Machinery Plant Monitor Panel (FIGURE 2-98) controls are located under panel in bottom third of monitor.

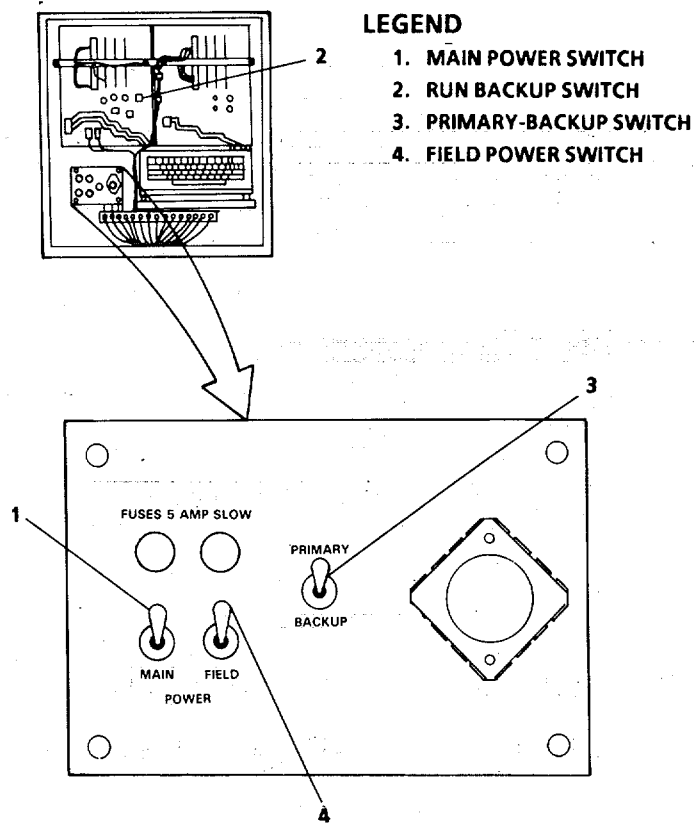

FIGURE 2-97. Engine Efficiency Panel

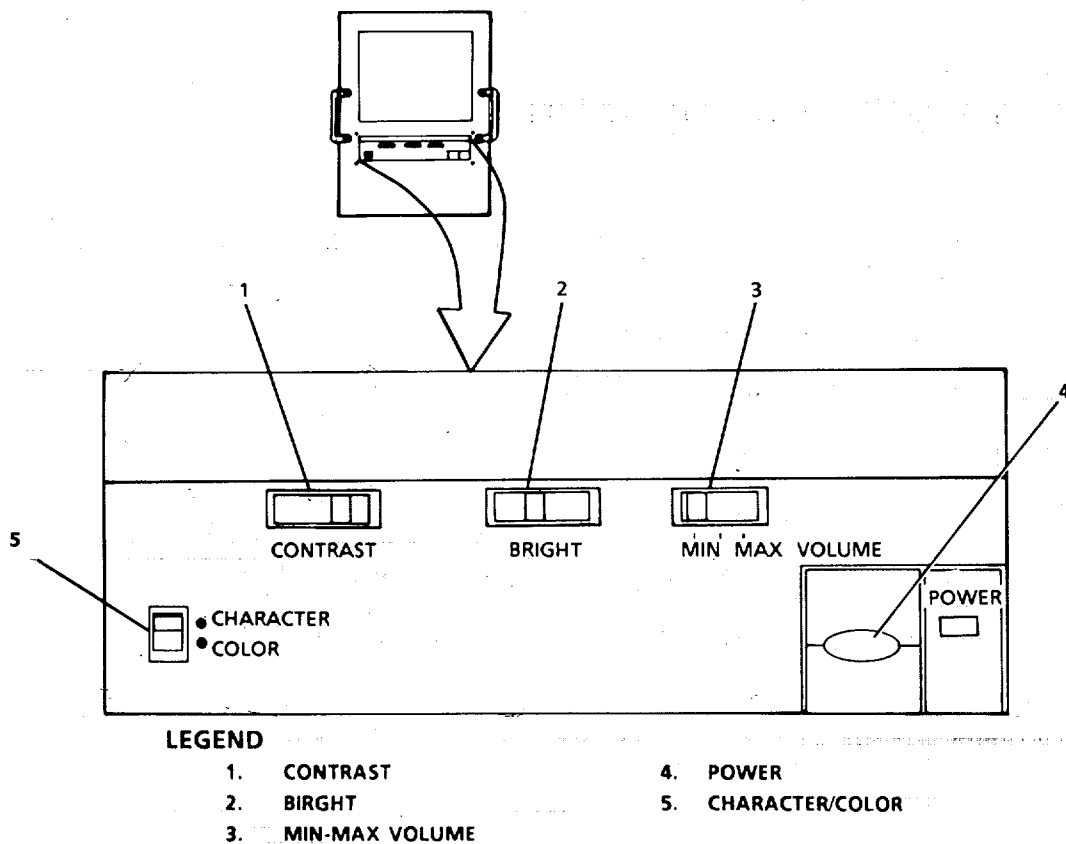

FIGURE 2-98. Machinery Plant Monitor Panel.

- (15) On Machinery Plant Monitor Panel (FIGURE 2-98), push on-off POWER switch (4); adjust CONTRAST control (1), BRIGHT control (2) so readout is clear and readable, and MIN-MAX VOLUME control (3). Ensure CHARACTER/COLOR pushbutton (5) is up for color, or down for black and white.
- (16) To set the time and date on Engine Room Console Panel (FIGURE 2-99) perform the following:
  - (a) Press + page (1) and - page (2) buttons simultaneously and hold until instructions appear on screen.
  - (b) After 5 seconds PROGRAMMING MODE will appear on display (3) and menu will appear on Machinery Plant Monitor (FIGURE 2-98) screen.

**NOTE**

If these switches are not held long enough, the screen display will switch to master index (PAGE 1).

- (c) Perform required functions as listed on menu, including setting of year, month, day, hour, and minutes.
- (d) Any new alarm received will terminate time set mode.

**2-7. Fire Main and Foam System.**

a. Fire Main Activation.

- (1) Open BB-23, SEACHEST SUCT (26, FIGURE 2-100).

**NOTE**

Ensure BB-35, SEACHEST VENT ISOLATION (3) and BB-36, SEACHEST VENT (5) are open.

- (2) Open BB-22, ISLN-SEACHEST (25).
- (3) Open FM-18, FIRE PUMP NO. 1 SUCT (21).
- (4) Open FM-17, FIRE PUMP NO. 2 SUCT (18).
- (5) Open FM-14, NO. 1 FIRE PUMP DISCH (16).
- (6) Open FM-25, NO. 1 FIRE PUMP STRAINER ISOLATION (20).
- (7) Open FM-26, NO. 2 FIRE PUMP STRAINER ISOLATION (19).
- (8) Open FM-15, NO. 2 FIRE PUMP DISCH (15).
- (9) Open FM-10, FIREMAIN ISLN (6).

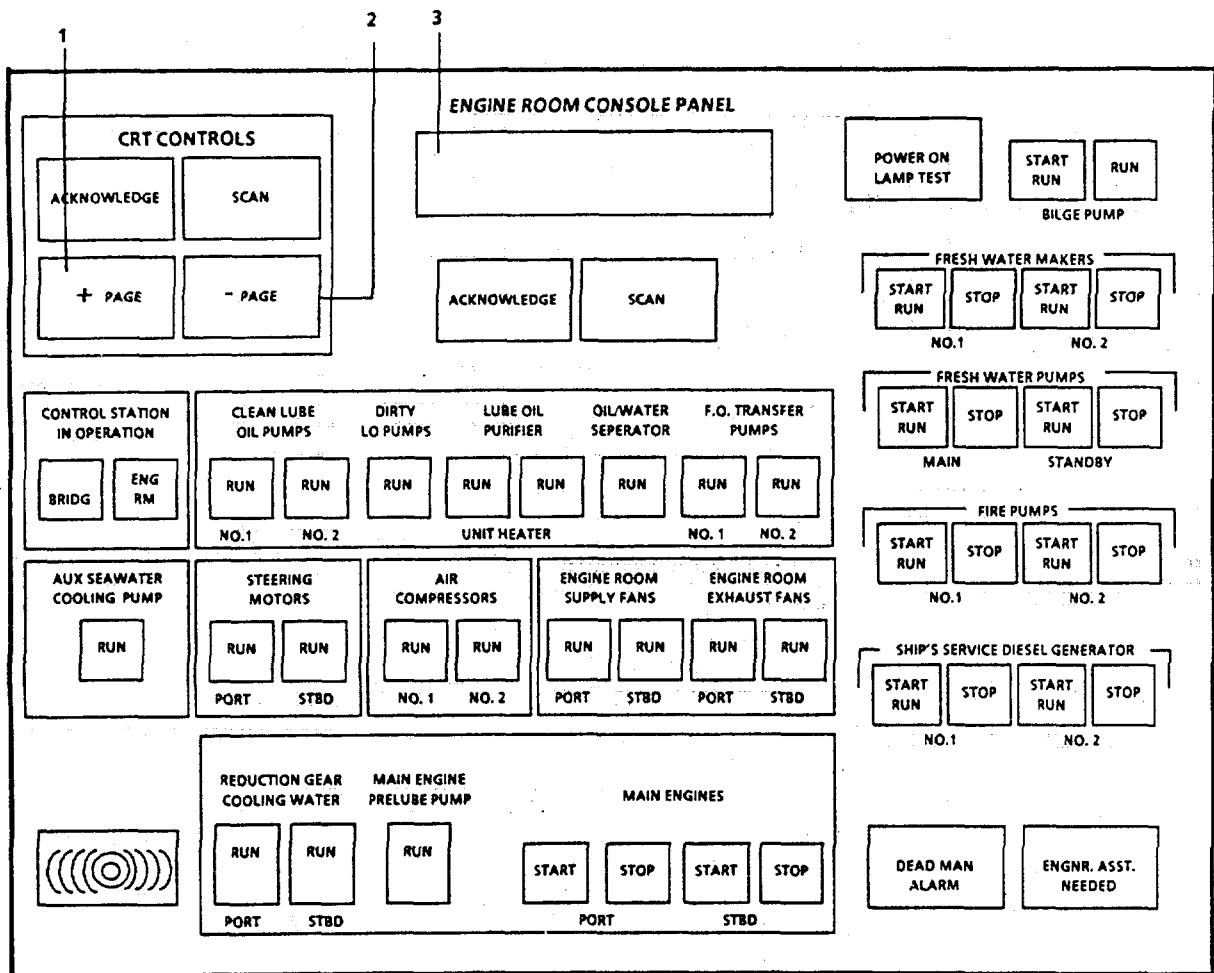

**LEGEND**

- 1. + PAGE
- 2. - PAGE
- 3. DISPLAY

FIGURE 2-99. Engine Room Console Panel.

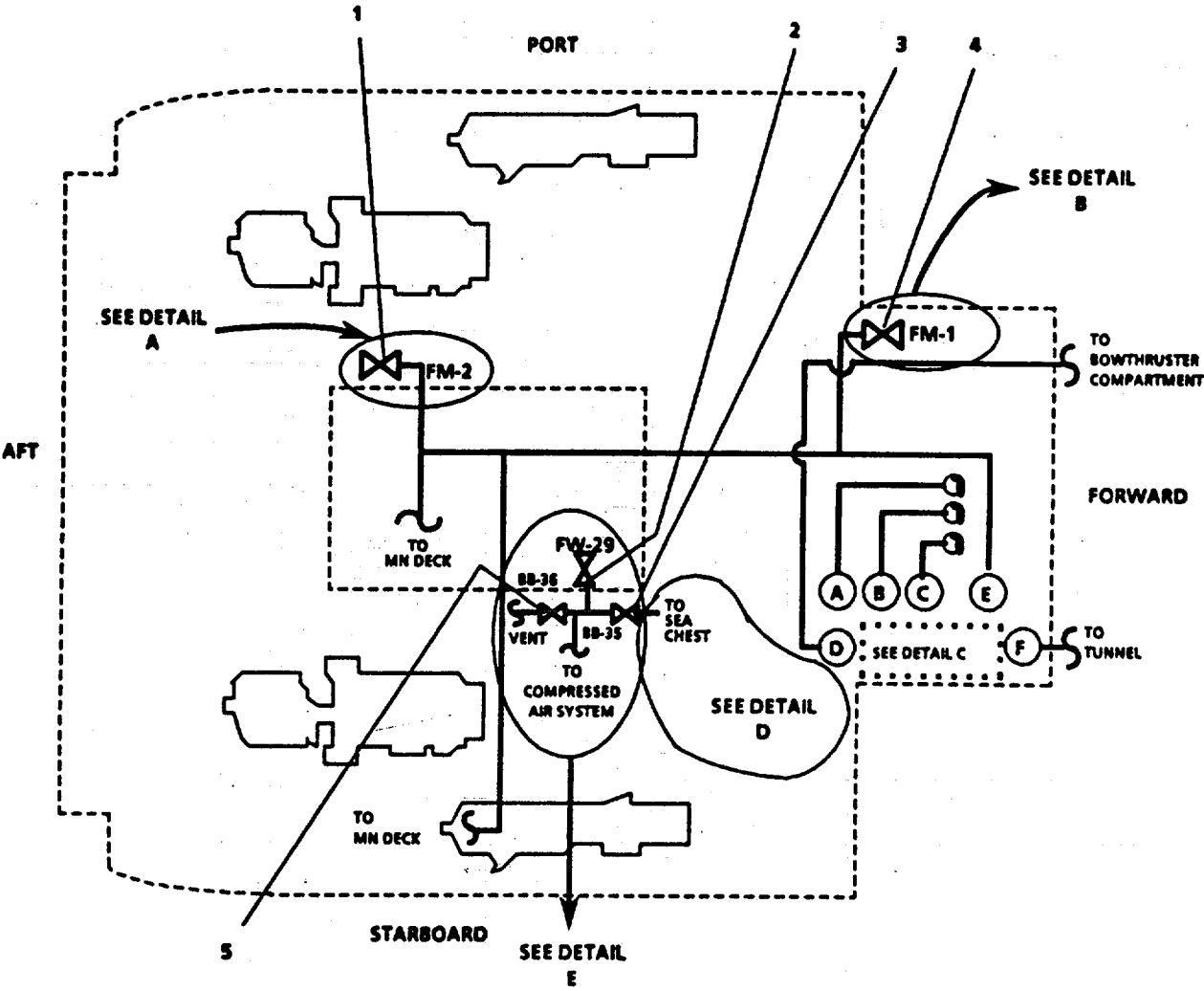

FIGURE 2-100. Fire Main Foam Piping System (Sheet 1 of 12)

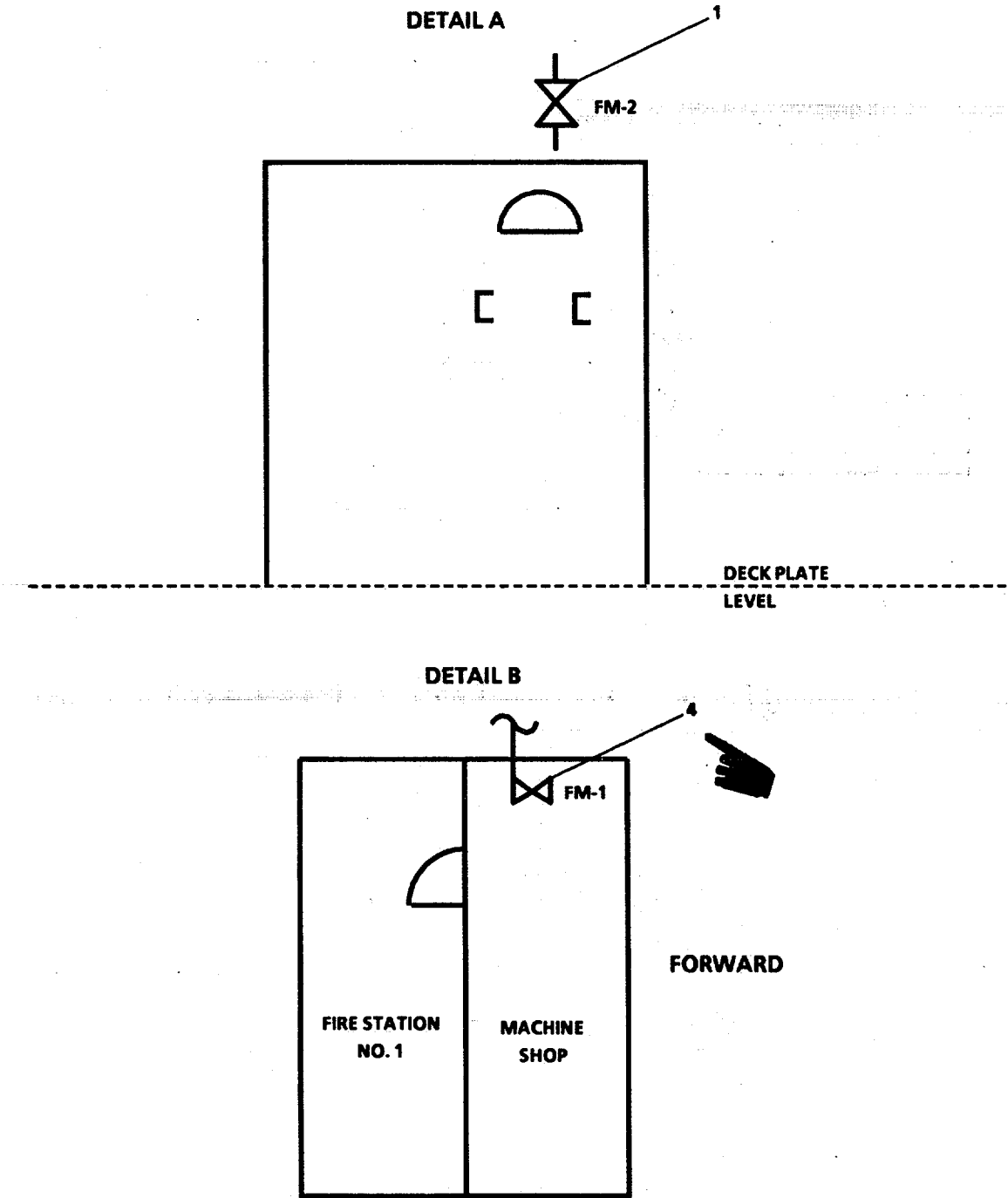
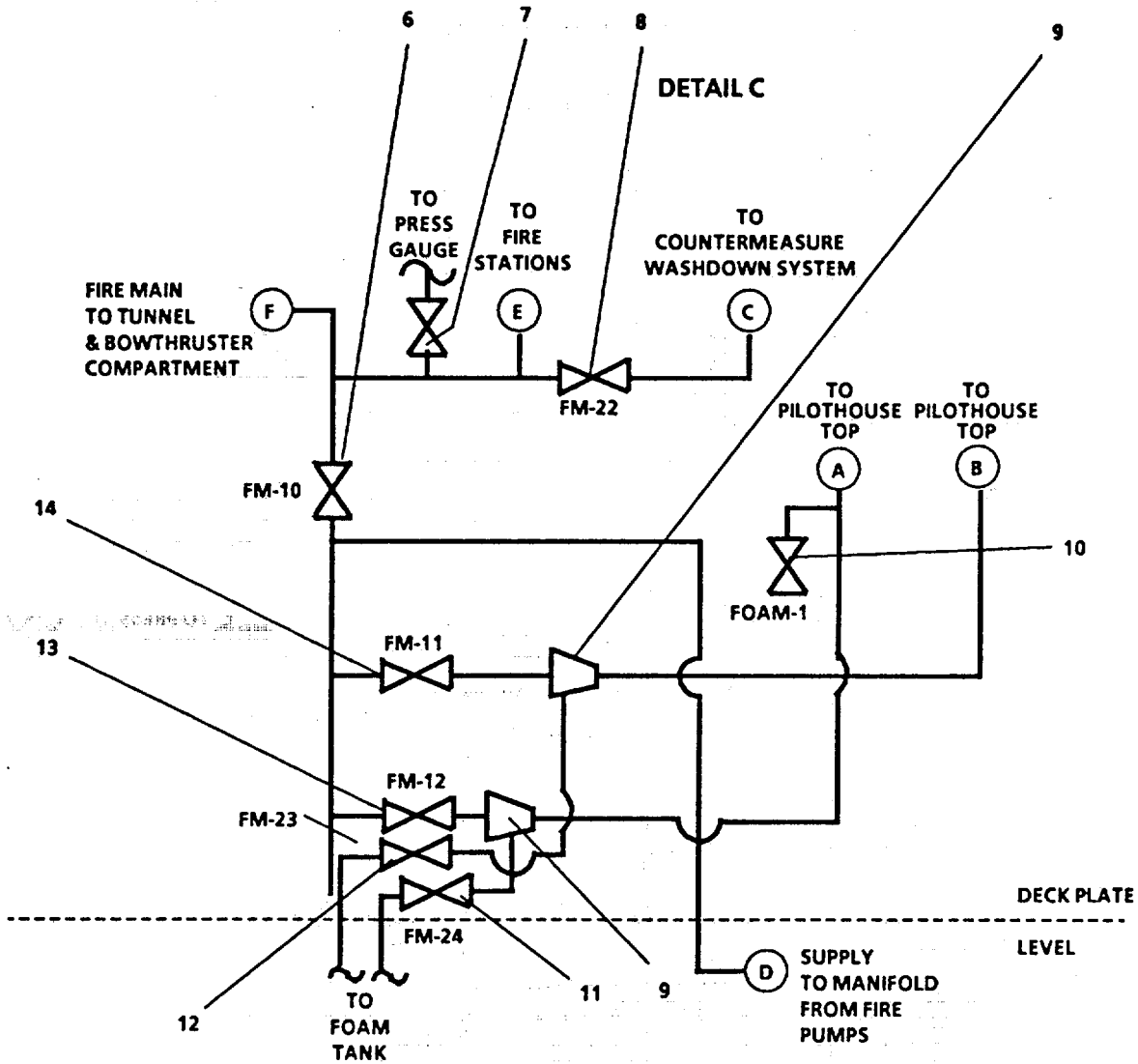

FIGURE 2-100. Fire Main Foam Piping System (Sheet 2 of 12)





**LOOKING STARBOARD AT PORT BULKHEAD OF STOREROOM**

FIGURE 2-100. Fire Main Foam Piping System (Sheet 3 of 12)

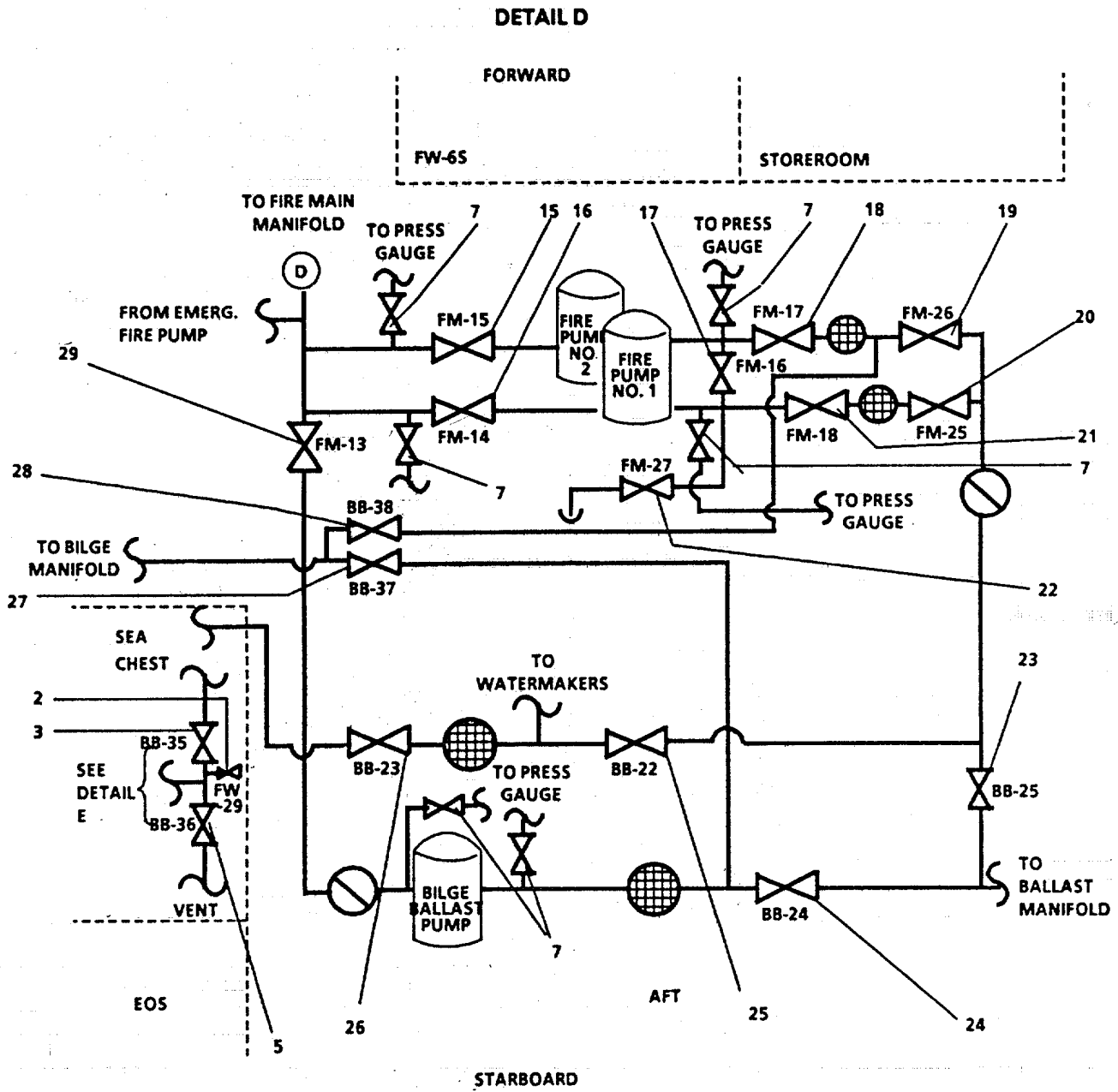

FIGURE 2-100. Fire Main Foam Piping System (Sheet 4 of 12)

DETAIL E

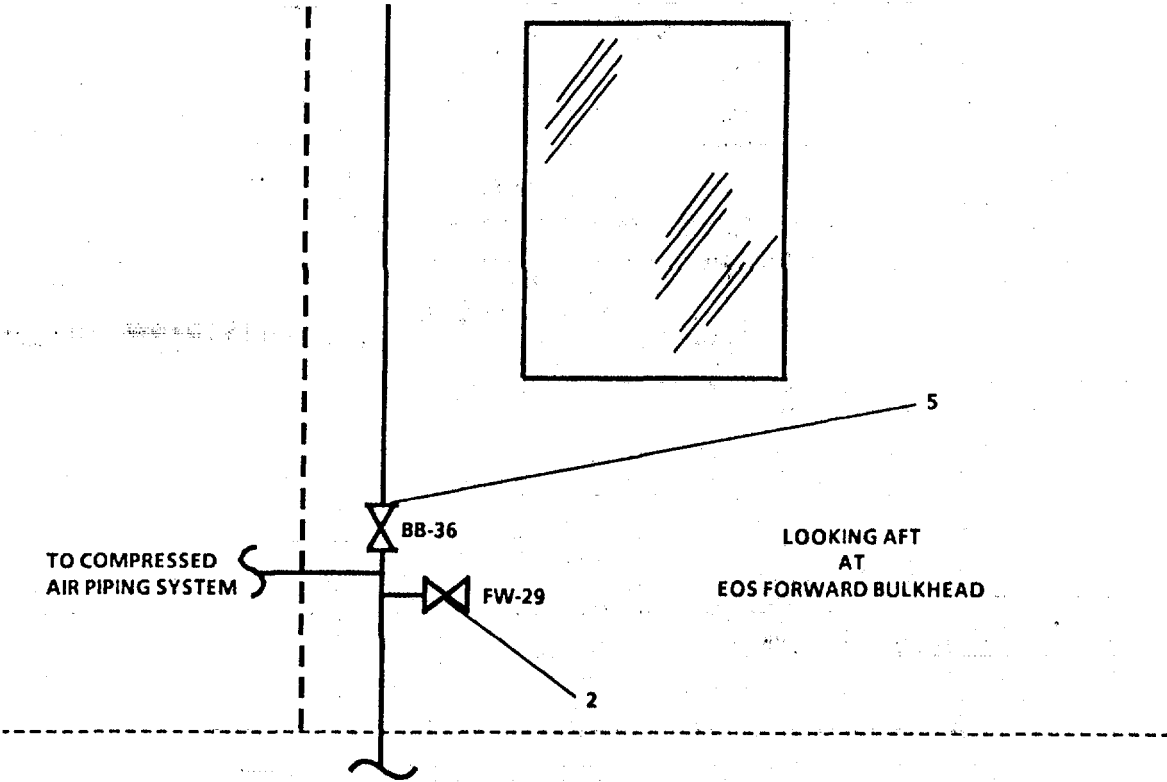

FIGURE 2-100. Fire Main Foam Piping System (Sheet 5 of 12)

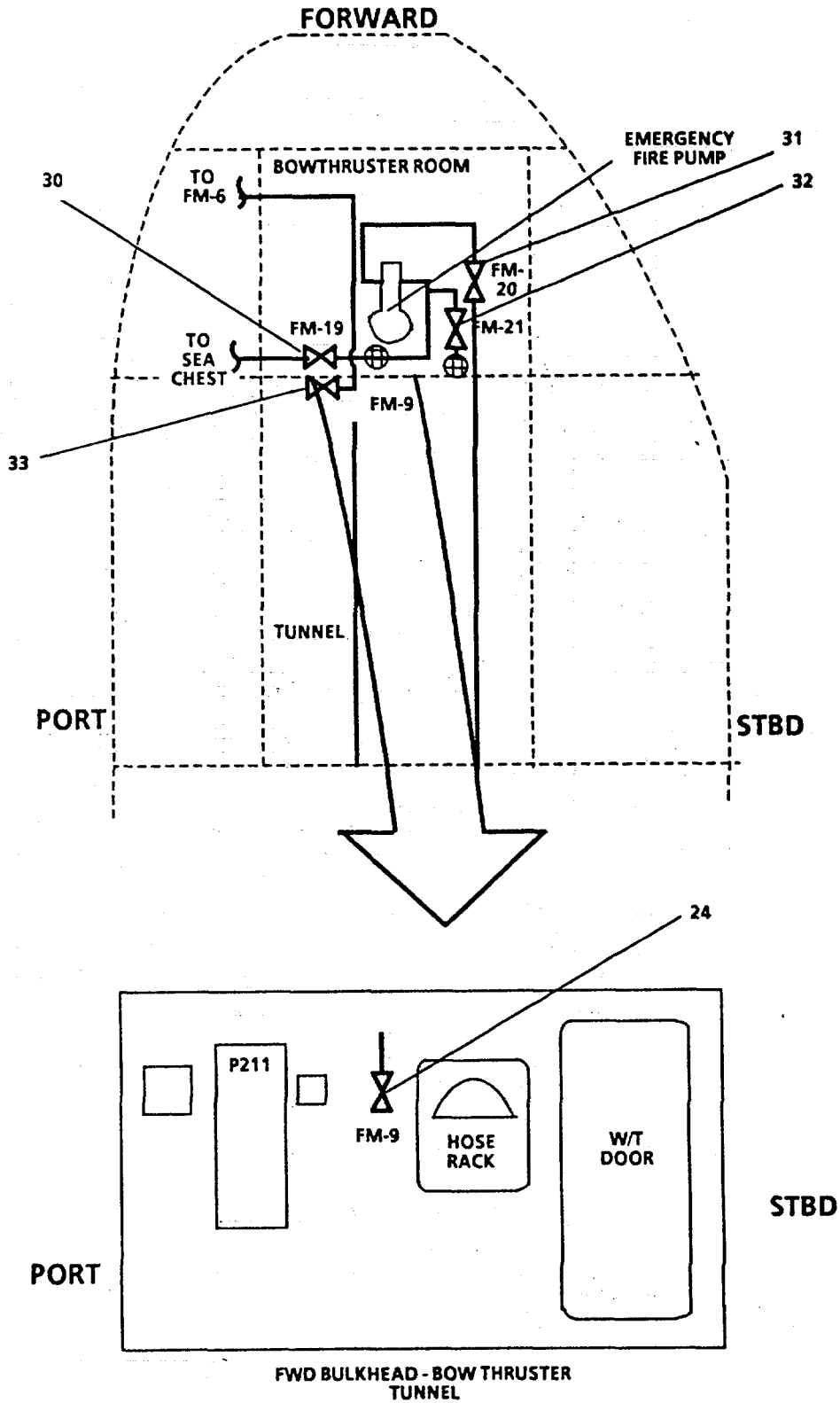

FIGURE 2-100. Fire Main Foam Piping System (Sheet 6 of 12)

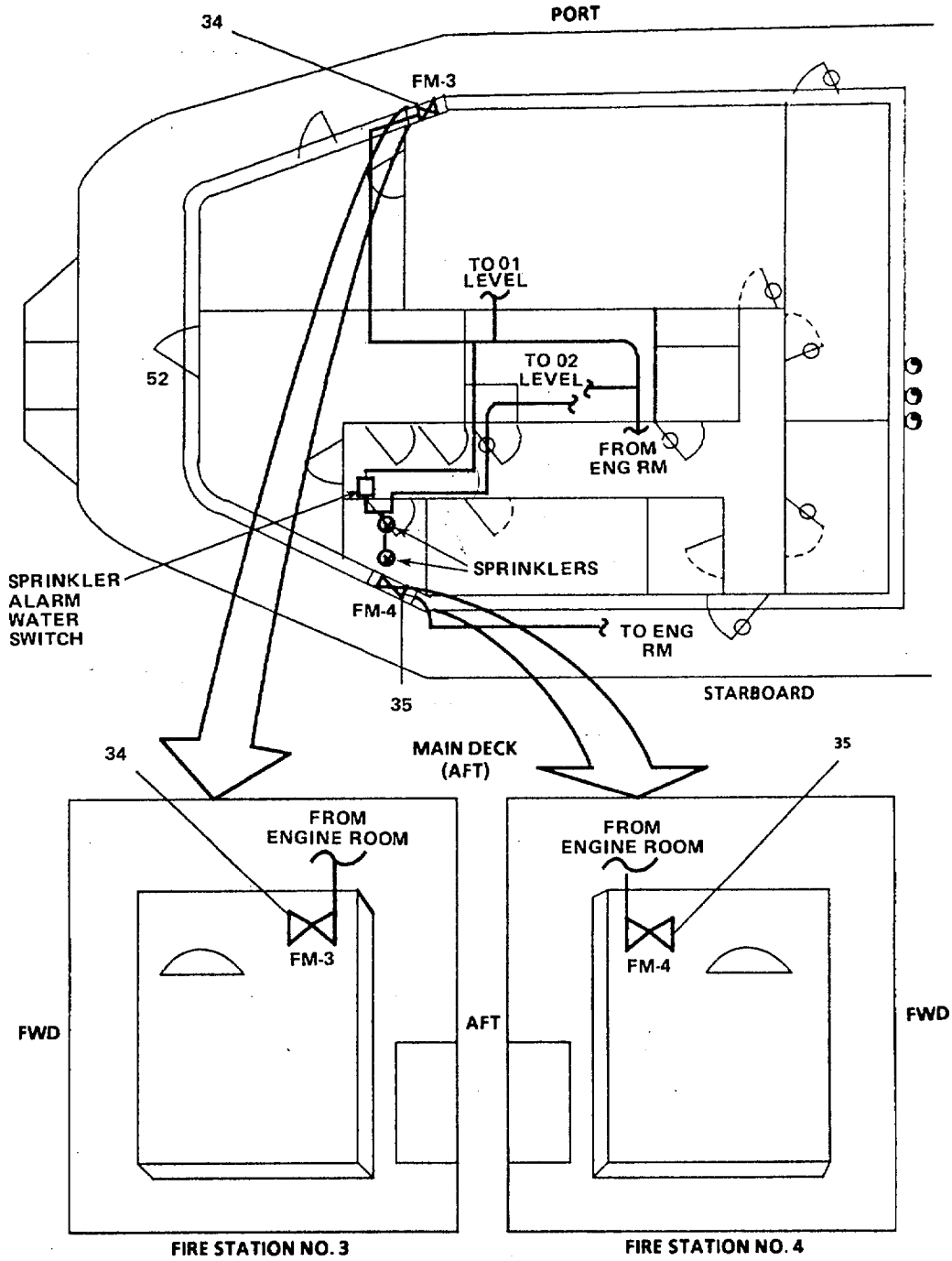

FIGURE 2-100. Fire Main and Foam Piping System (Sheet 7 of 12).

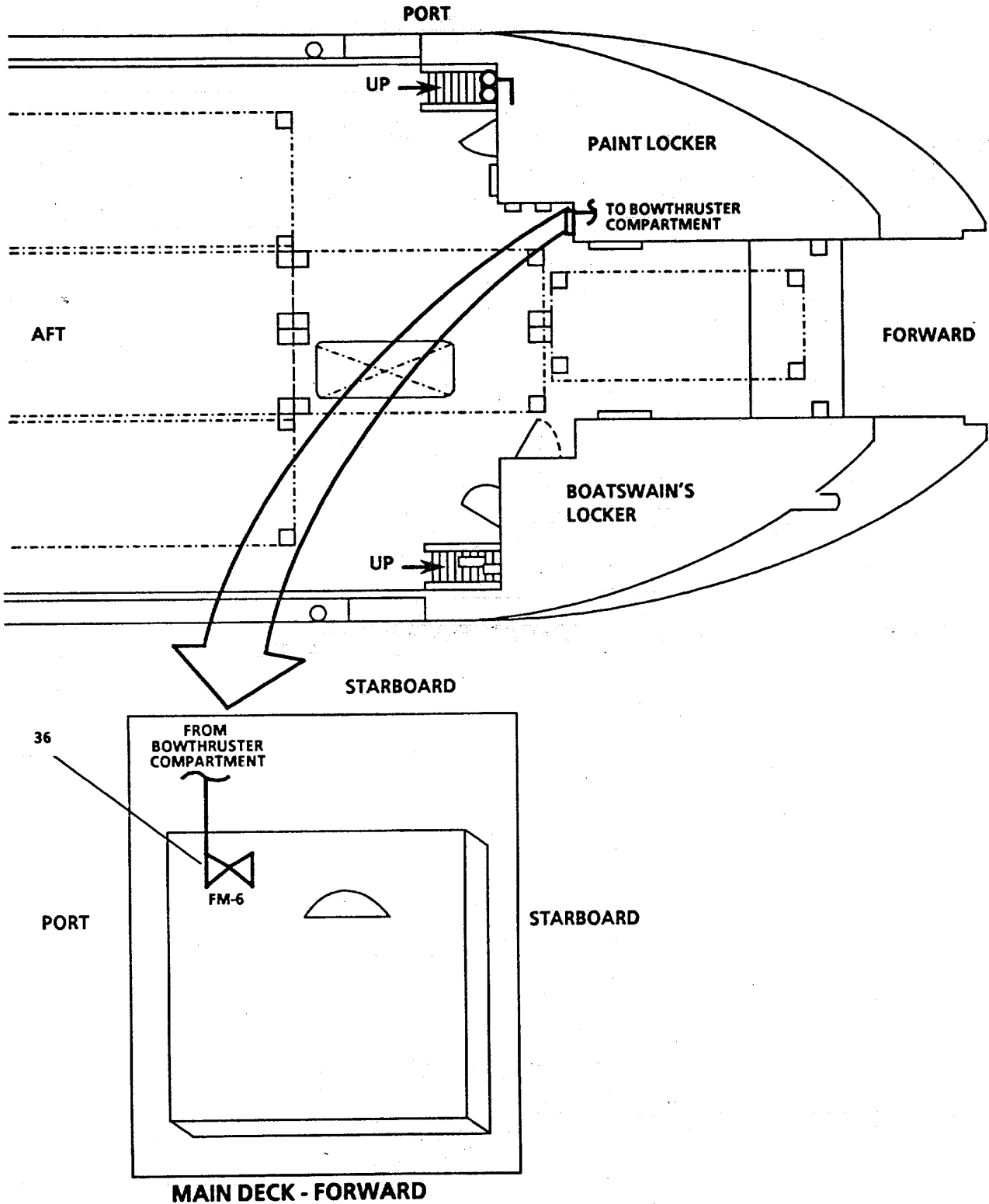

FIGURE 2-100. Fire Main and Foam Piping System (Sheet 8 of 12).

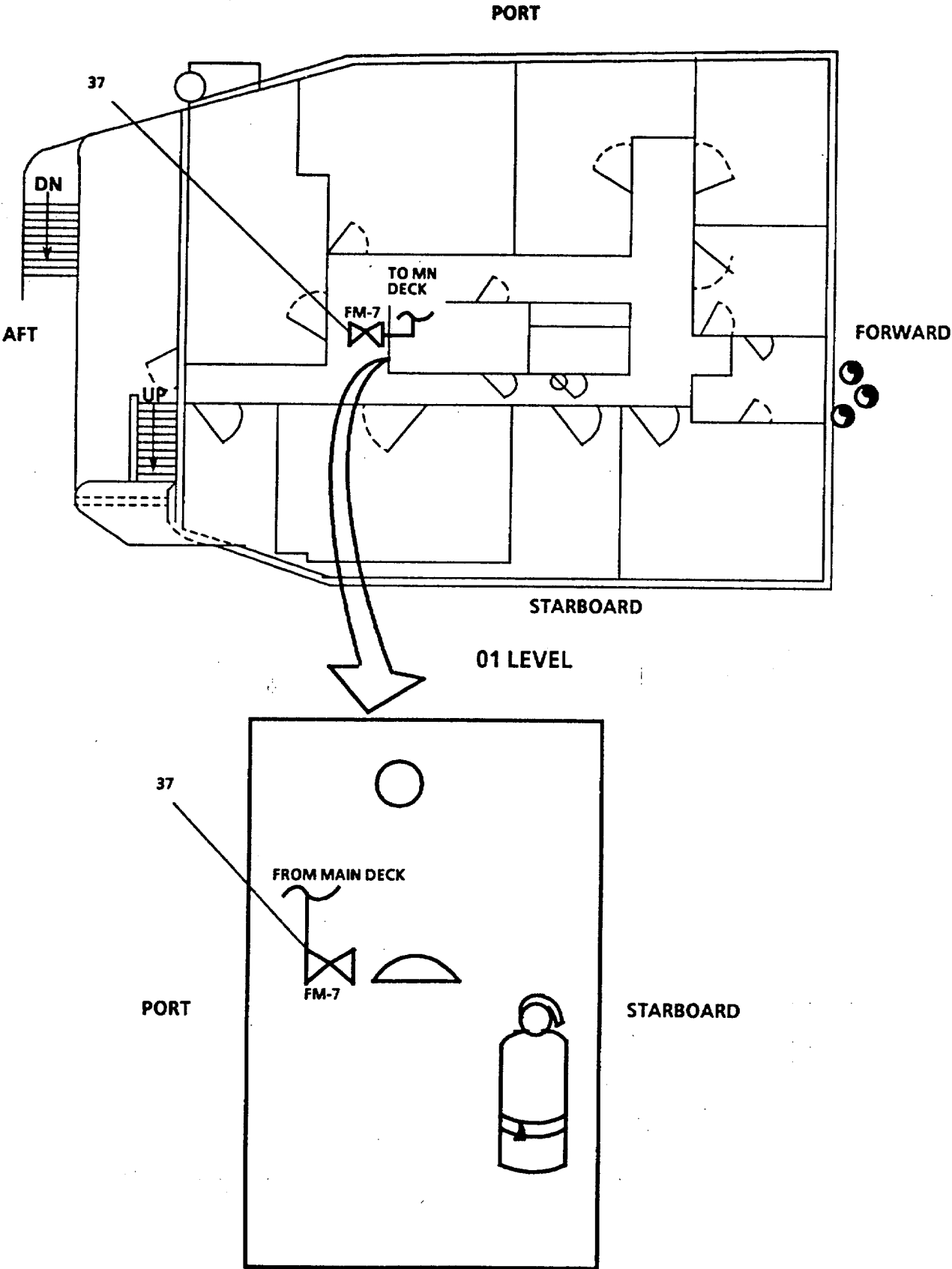

FIGURE 2-100. Fire Main and Foam Piping System (Sheet 9 of 12).

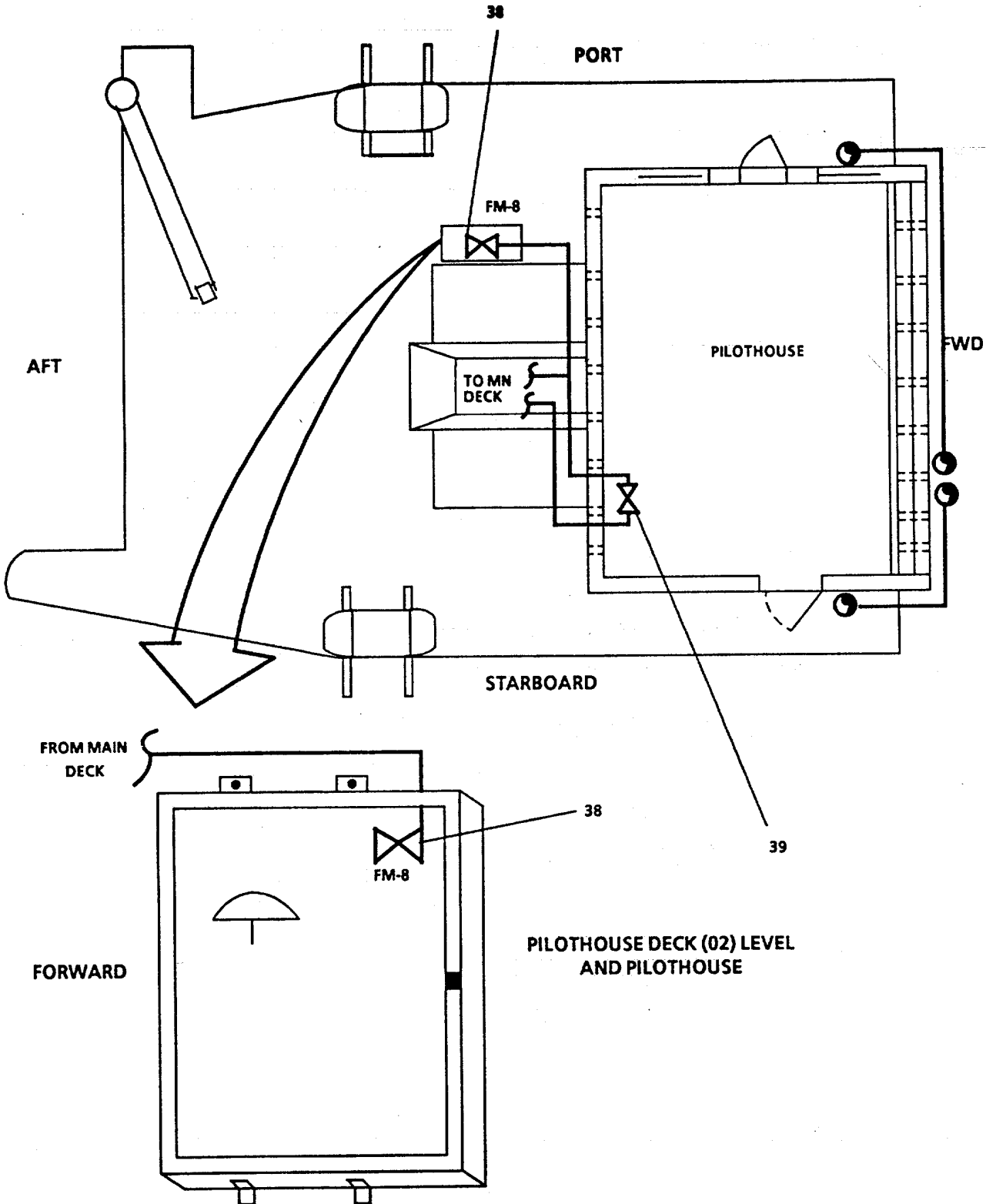

FIGURE 2-100. Fire Main and Foam Piping System (Sheet 10 of 12).



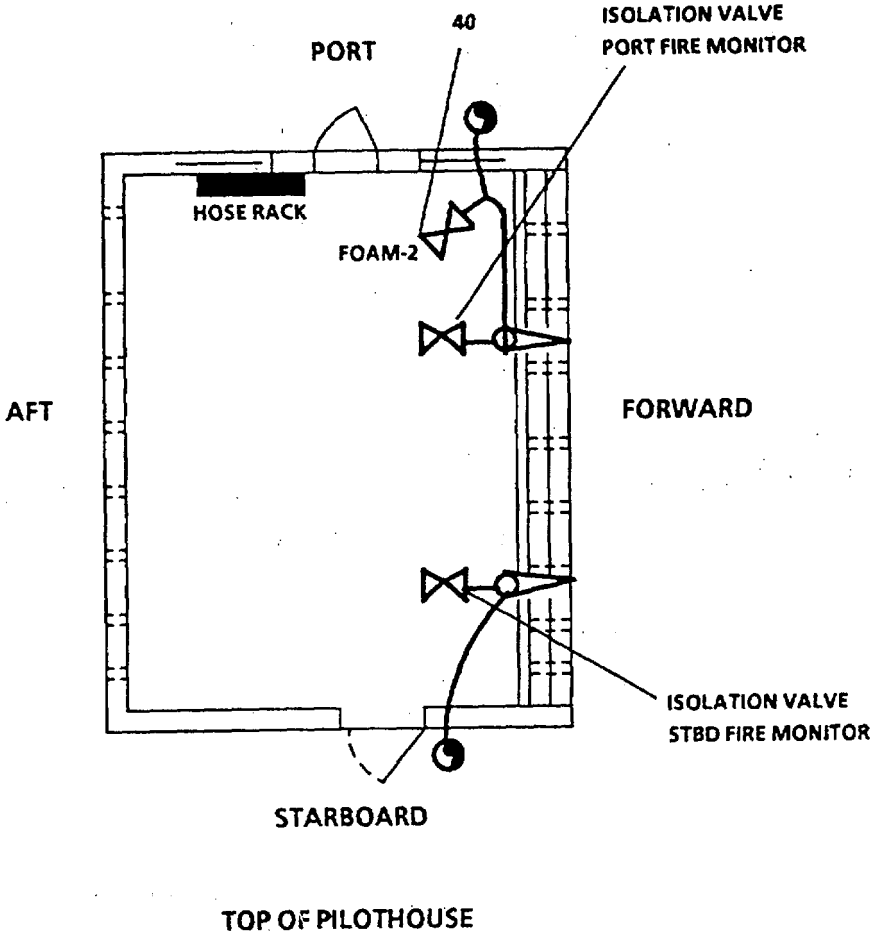

FIGURE 2-100. Fire Main and Foam Piping System (Sheet 11 of 12).

## LEGEND

- |   |  |
|---|--|
| 1. FM-2, FIRE STA 2 ISLN                                    | 21. FM-18, FIRE PUMP NO. 1 SUCT                            |
| 2. FW-29, SEA CHEST HOT FW CONN                             | 22. FM-27, ENG RM EMERG BILGE SUCT                         |
| 3. BB-35, SEACHEST VENT ISOLATION                           | 23. BB-25, ISLN-SEA CHEST                                  |
| 4. FM-1, FIRE STA 1 ISLN                                    | 24. BB-24, SUCT-BILGE/BALLAST PUMP                         |
| 5. BB-36, SEACHEST VENT                                     | 25. BB-22, ISLN - SEA CHEST                                |
| 6. FM-10, FIREMAIN ISLN                                     | 26. BB-23 SEA CHEST SUCT                                   |
| 7. PRESSURE GAUGE ISOLATION                                 | 27. BB-37, CROSS CONN TO BILGE MANIFOLD                    |
| 8. FM-22, CM WASHDOWN ISLN                                  | 28. BB8-38, CROSS CONN FIRE PUMP SUCT TO BILGE<br>MANIFOLD |
| 9. EDUCTOR  | 29. FM-13, FIREMAN & BALLAST CROSS CONN                    |
| 10. FOAM-1, FOAM STA I ISLN                                 | 30. FM-19, EMERG FIRE PUMP                                 |
| 11. FM-24, PORT FOAM MONITOR ISLN                           | 31. FM-20, EMERG FIRE PUMP DISCH                           |
| 12. FM-23, STBD FOAM MONITOR ISLN                           | 32. FM-21, EMERG BILGE SUCT                                |
| 13. FM-12, FOAM STA I-& STBD MONITOR ISLN                   | 33. FM-9, FIRE STA ISLN                                    |
| 14. FM-11, FOAM STA 2 & PORT MONITOR ISLN                   | 34. FM-3, FIRE STA 3 ISLN                                  |
| 15. FM-1 5, NO. 2 FIRE PUMP DISCH                           | 35. FM4, FIRE STA 4 ISLN                                   |
| 16. FM-14, NO. 1 FIRE PUMP DISCH                            | 36. FM-6, FIRE STA 6 ISLN                                  |
| 17. FM-1 6, FIRE PUMP 1 & 2 SUCT CROSS CONN                 | 37. FM-7, FIRE STA 7 ISLN                                  |
| 18. FM-17, FIRE PUMP NO. 2 SUCT                             | 38. FM-8, FIRE STA 8 ISLN                                  |
| 19. FM-26, NO. 2 FIRE PUMP SISCH OLATION                    | 39. ARMS ROOM SPRINKLER MANUAL<br>VALVE                    |
| 20. FM-25. NO. 1 FIRE PUMP STRAINER ISOLATION<br>ACTIVATION | 40. FOAM-2, FOAM STA 2 ISLN                                |

FIGURE 2-100. Fire Main and Foam Piping System (Sheet 12 of 12).

**CAUTION**

Do not turn on circuit breakers when no fire is present or valves have not been properly aligned. Damage to pumps could occur.

- (10) On Main Switchboard (FIGURE 2-101) set FIRE PUMP NO. 1 circuit breaker (1) and FIRE PUMP NO. 2 circuit breaker (2) to ON position.
- (11) On Fire Pump Motor Controllers (FIGURE 2-102) set ON-OFF switch (1) to ON position.
- (12) On Fire Pump Motor Switch (FIGURE 2-103), press START pushbutton (1) for both fire pumps.

## b. Fire Station.

- (1) Fire/Airflow Damper Operation.

**NOTE**

Airflow dampers are normally used to balance the amount of air provided to the various compartments supplied. In the event of a fire, these dampers could be aligned to prevent "fanning" the fire. The following procedure provides instructions for closing and opening the damper. Damper locations are provided in Table 2-3.

## (a) Close damper.

- (1) Select damper(s) to be closed from Table 2-3.

**WARNING**

Use caution when removing retaining screws to ensure the access cover does not fall causing personal injury.

- (2) Remove and save access cover retaining screws.
- (3) Lower/open access cover.
- (4) Remove and save locking pin.
- (5) Move damper lever in CLOSE direction indicated on lever guide.
- (6) Reinstall locking pin.
- (7) Raise/close access cover and hold closed with one hand.
- (8) Reinstall access cover retaining screws finger tight.

(9) Tighten retaining screws snug with screwdriver. DO NOT OVER- TIGHTEN.

(b) Open damper.

(1) Select damper(s) to be closed from Table 2-3.

**WARNING**

Use caution when removing retaining screws to ensure the access cover does not fall causing personal injury.

(2) Remove and save access cover retaining screws.

(3) Lower/open access cover.

(4) Remove and save locking pin.

(5) Move damper lever in OPEN direction indicated on lever guide.

(6) Reinstall locking pin.

(7) Raise/close access cover and hold closed with one hand.

(8) Reinstall access cover retaining screws finger tight.

(9) Tighten retaining screws snug with screwdriver. DO NOT OVER- TIGHTEN.

Table 2-3. Airflow/fire Dampers.

NUMBER	LOCATION
1	01 Level, 2 crewmember stateroom aft, outboard aft corner approximately chest level.
2	01 Level passageway outside 4 crewmember stateroom, across from fire station and flush with Deck.
3	Main Deck stairwell overhead as entering stairwell.
4	Galley, overhead as entering from passageway.
5	Provision Storeroom overhead as entering from food preparation area.
6	Provisions Storeroom over freezer next to forward bulkhead.
7	Emergency Generator Room-overhead of Switchboard aft end.
8	Emergency Generator Room overhead of door to passageway
9	Arms Control Room overhead of door.
10	01 Passageway overhead next to Sprinkler Handle.
11	Sickbay overhead above shelf-and safe.

(2) Fire station operation.

- (a) Ensure hose is connected to FIRE STA ISLN valve.
- (b) Remove fire hose from hose storage rack.
- (c) Extend hose to its full length.
- (d) Ensure nozzle valve is closed.

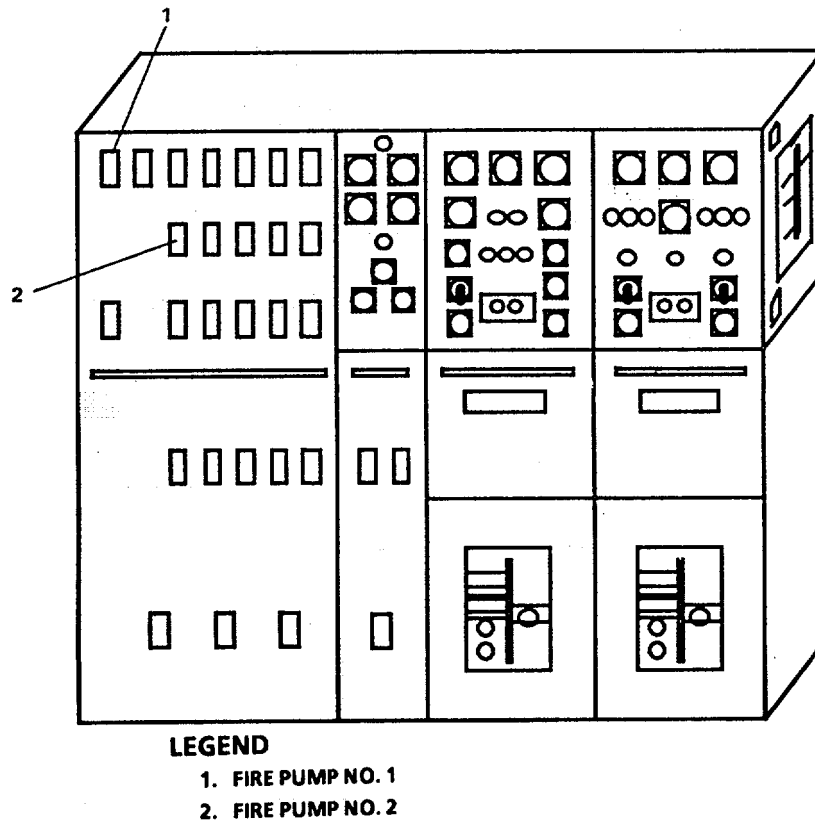
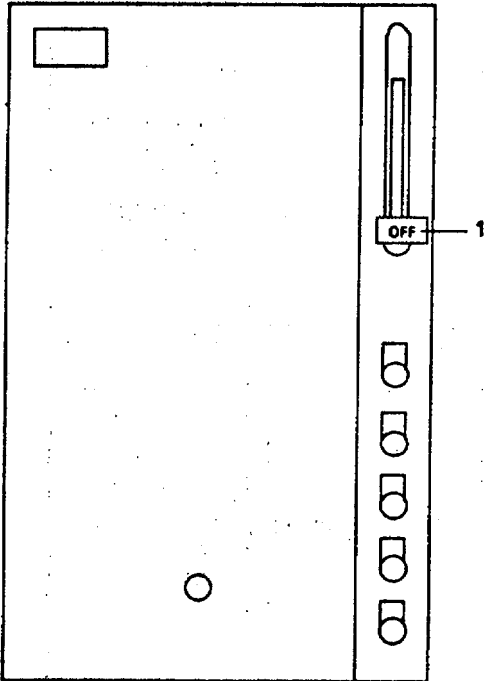
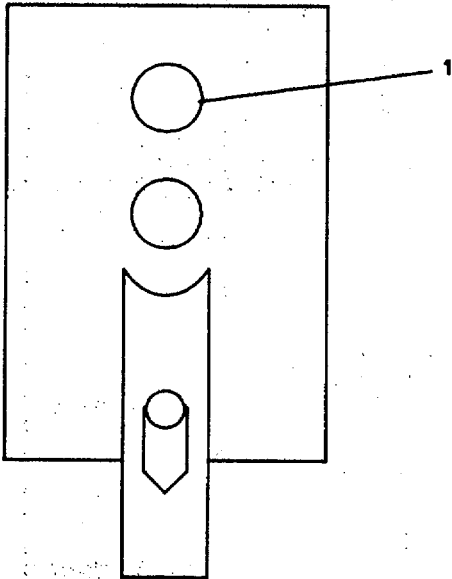

FIGURE 2-101. Main Switchboard.



**LEGEND**  
1. ON-OFF

FIGURE 2-102.. Fire Pump Motor Controllers.



**LEGEND**  
1. START

FIGURE 2-103. Fire Pump Motor Switch.

2-320.3/(2-320.4 blank)

- (e) Open FIRE STA ISLN valve.

**WARNING**

Hold nozzle using a firm grip. If not held firmly, the nozzle will thrash about and may cause serious personal injury.

- (f) Direct nozzle at fire.
- (g) Open nozzle valve.

(2) Fire station shutdown. At fire station selected perform following:

- (a) Close nozzle valve.
- (b) Close FIRE STA ISLN valve.
- (c) Open nozzle valve to relieve pressure in fire hose.
- (d) Disconnect hose from FIRE STA ISLN valve.
- (e) Open nozzle valve.
- (f) At nozzle end, raise hose and "walk back," continuing to raise hose, to FIRE STA ISLN valve connection. This will drain hose.
- (g) Connect hose to FIRE STA ISLN valve.
- (h) Close nozzle valve.
- (i) Stow hose on the hose storage rack.

c. Foam System Activation (FIGURE 2-100).

- (1) Open BB-23, SEACHEST SUCT (26).

NOTE

Ensure BB-35, SEACHEST VENT ISOLATION (3) and BB-36, SEACHEST VENT (5) are open.

- (2) Open BB-22, ISLN-SEACHEST (25).
- (3) Open FM-18, FIRE PUMP NO. 1 SUCT (21).
- (4) Open FM-17, FIRE PUMP NO. 2 SUCT (18).
- (5) Open FM-14, NO. 1 FIRE PUMP DISCH (16).
- (6) Open FM-25, NO. 1 FIRE PUMP STRAINER ISOLATION (20).
- (7) Open FM-26, NO. 2 FIRE PUMP STRAINER ISOLATION (19).



- (8) Open FM-15, NO. 2 FIRE PUMP DISCH (15).
- (9) Open FM-10, FIREMAIN ISLN (6).

CAUTION

Do not turn an circuit breakers when no fire is present or valves have not been properly aligned. Damage to pump could result.

- (10) On Main Switchboard (FIGURE 2-101) set FIRE PUMP NO. 1 circuit breaker (1) and FIRE PUMP NO. 2 circuit breaker (2) to ON position.
- (11) On Fire Pump Motor Controllers (FIGURE 2-102) set ON-OFF switch (1) to ON position.
- (12) On Fire Pump Motor Switch (FIGURE 2-103), press START pushbutton (1) for both fire pumps.
- (13) Open FM-23, STBD FOAM MONITOR ISLN (12).
- (14) Open FM-24, PORT FOAM MONITOR ISLN (11).
- (15) Open FM-11, FOAM STA 2 and PORT MONITOR ISLN (14).
- (16) Open FM-12, FOAM STA 1 AND STBD MONITOR ISLN (13).

d. Foam Station.

- (1) Foam station operation. At foam station selected perform following:
  - (a) Ensure hose is connected to foam station isolation valve.
  - (b) Remove hose from hose storage rack.
  - (c) Extend hose to its full length.
  - (d) Ensure nozzle valve is closed.
  - (e) Open FOAM station isolation valve.

WARNING

Hold nozzle using a firm grip. If not held firmly, the nozzle will thrash about and may cause serious personal injury.

- (f) Direct nozzle at base of fire.
- (g) Open nozzle valve.

(2) Foam station shutdown. At foam station selected perform following:

- (a) Close nozzle valve.
- (b) Close FM-23, STBD FOAM MONITOR ISLN (12).
- (c) Close FM-24, PORT FOAM MONITOR ISLN (11).
- (d) Open nozzle valve.
- (e) Observe flow until sea water is output.
- (f) Close nozzle valve.
- (g) Close FOAM station isolation valve.
- (h) Open FM-23, STBD FOAM MONITOR ISLN (12).
- (i) Open FM-24, PORT FOAM MONITOR ISLN (11).
- (j) Open nozzle valve to relieve pressure in fire hose.
- (k) Disconnect hose from foam station isolation valve.
- (l) Open nozzle valve.
- (m) At nozzle end, raise hose and "walk back," continuing to raise hose, to FOAM station isolation valve connection. This will drain hose.
- (n) Connect hose to foam station isolation valve.
- (o) Close nozzle valve.
- (p) Stow hose on the hose storage rack.

e. Fire Monitor

- (1) Fire Monitor Operation.
  - (a) Direct monitor at fire.
  - (b) Open isolation valve for desired monitor.
- (2) Fire Monitor Shutdown (after use with sea water).
  - (a) Close isolation valve for desired monitor.
  - (b) Secure monitor.
- (3) Fire Monitor Shutdown (after use with foam).
  - (a) Close FM-24, PORT FOAM MONITOR ISLN (11).
  - (b) Close FM-23, STBD FOAM MONITOR ISLN (12).

- (c) Observe flow until sea water is output.
- (d) Close isolation valve for desired monitor.
- (e) Secure monitor.

2-8. Compressed Piping Air System.

a. Align Compressed Air Piping System (FIGURE 2-104).

- (1) Close all valves in Compressed Air Piping System.
- (2) Open LPA-1, DISCH-AIR CPRSR NO. 1 (16).
- (3) Open LPA-2, DISCH-AIR CPRSR NO. 2 (23).
- (4) Open LPA-3-, ISLN-AIR RCVR NO. 1 (41).
- (5) Open LPA-4, ISLN-AIR RCVR NO. 2 (46).
- (6) Open LPA-28, PRESS GAGE AIR RCVR NO. 1 (39).
- (7) Open LPA-27, PRESS GAGE AIR RCVR NO. 2 (48).
- (8) Open LPA-5, SUPPLY TO PRESS RDCR (33).
- (9) Open LPA-6, SUPPLY TO MANF (35).
- (10) Open LPA-31, PRESS GAGE (36).
- (11) Open LPA-29, TO AIR CPRSR UNLOADERS (31).
- (12) Open LPA-30, PRESS SW (32).

b. On Auxiliary Machinery Motor Control Center (FIGURE 2-105), set AIR COMPRESSOR NO. 1 (P205-10) (3) and AIR COMPRESSOR NO. 2 (P205-11) (1) circuit breakers to ON position.

c. At air compressor TYPE-I Motor Switches (FIGURE 2-106).

- (1) Release STOP button (2) by sliding LOCK (3) down.
- (2) Press START button (1).

NOTE

Compressors may also be started at Auxiliary Machinery Control Center with START pushbutton (2, FIGURE 2-105) and (4).

d. When pressure in the system reaches 125 psi, activate control air as follows:

- (1) Open LPA-8, SUPPLY TO CONTROL AIR (25, FIGURE 2-104).

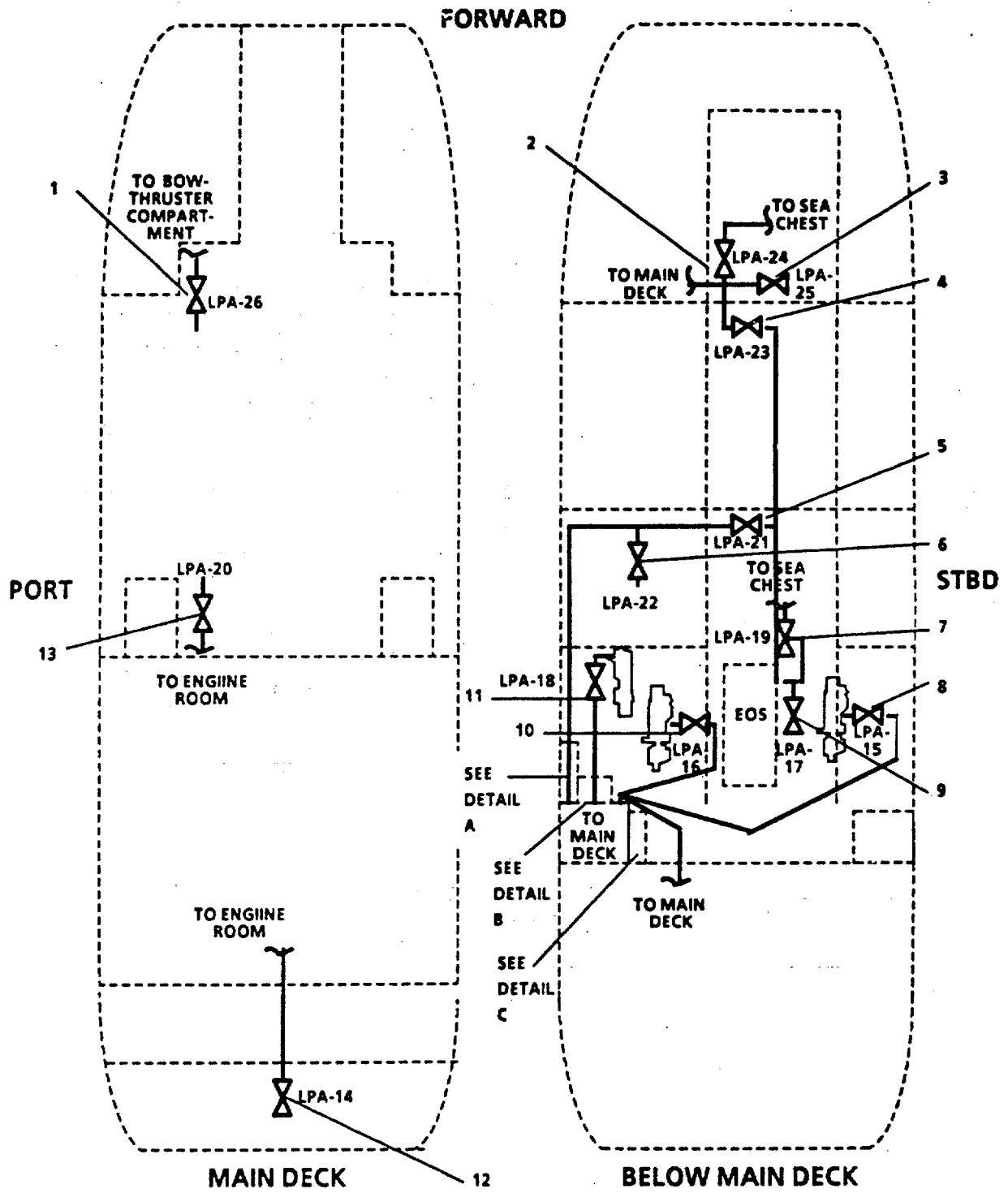

FIGURE 2-104. Compressed Air Piping System (Sheet 1 of 5)

DETAIL A

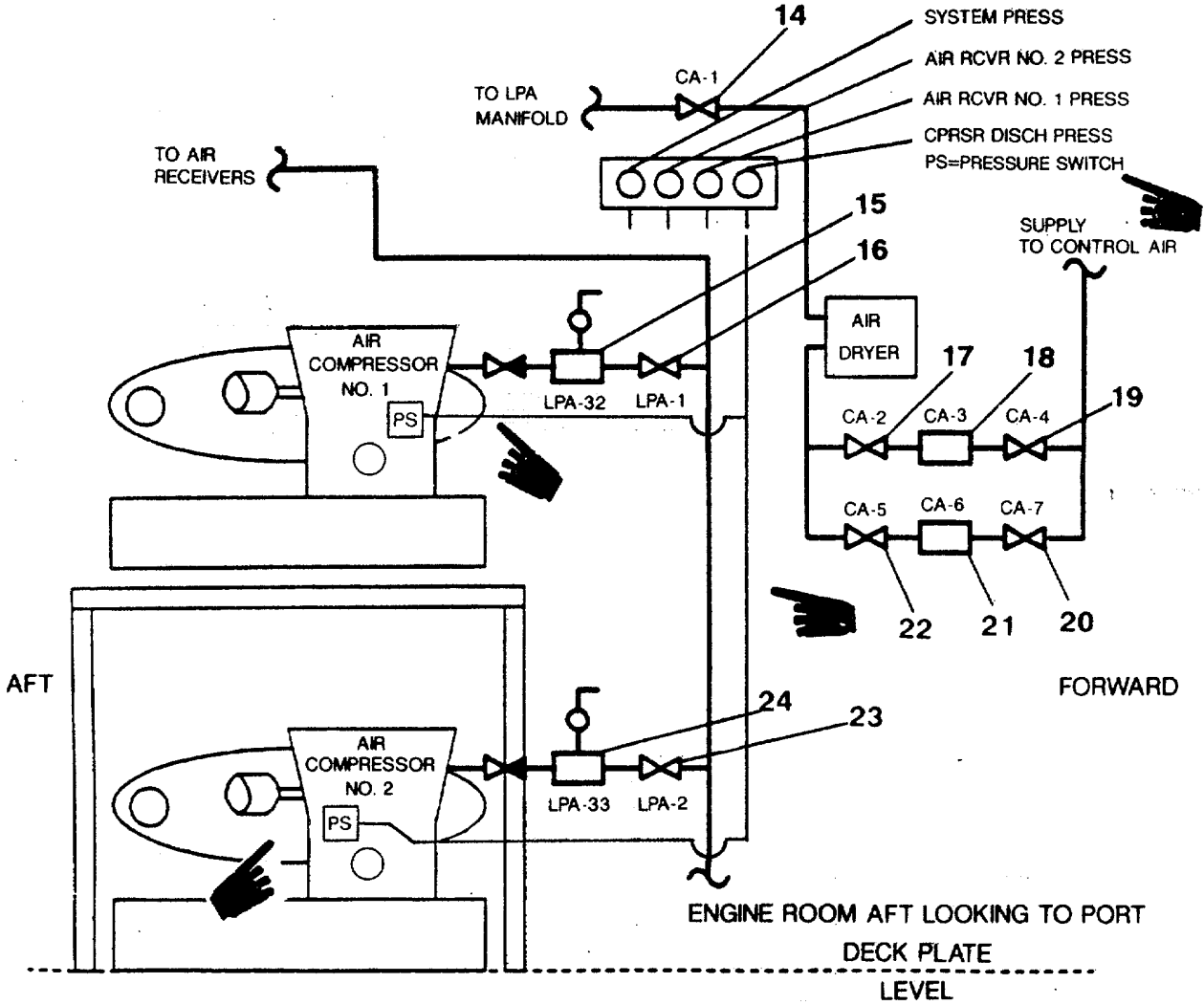

FIGURE 1-104. Compressed Air Piping System (Sheet 2 of 5)

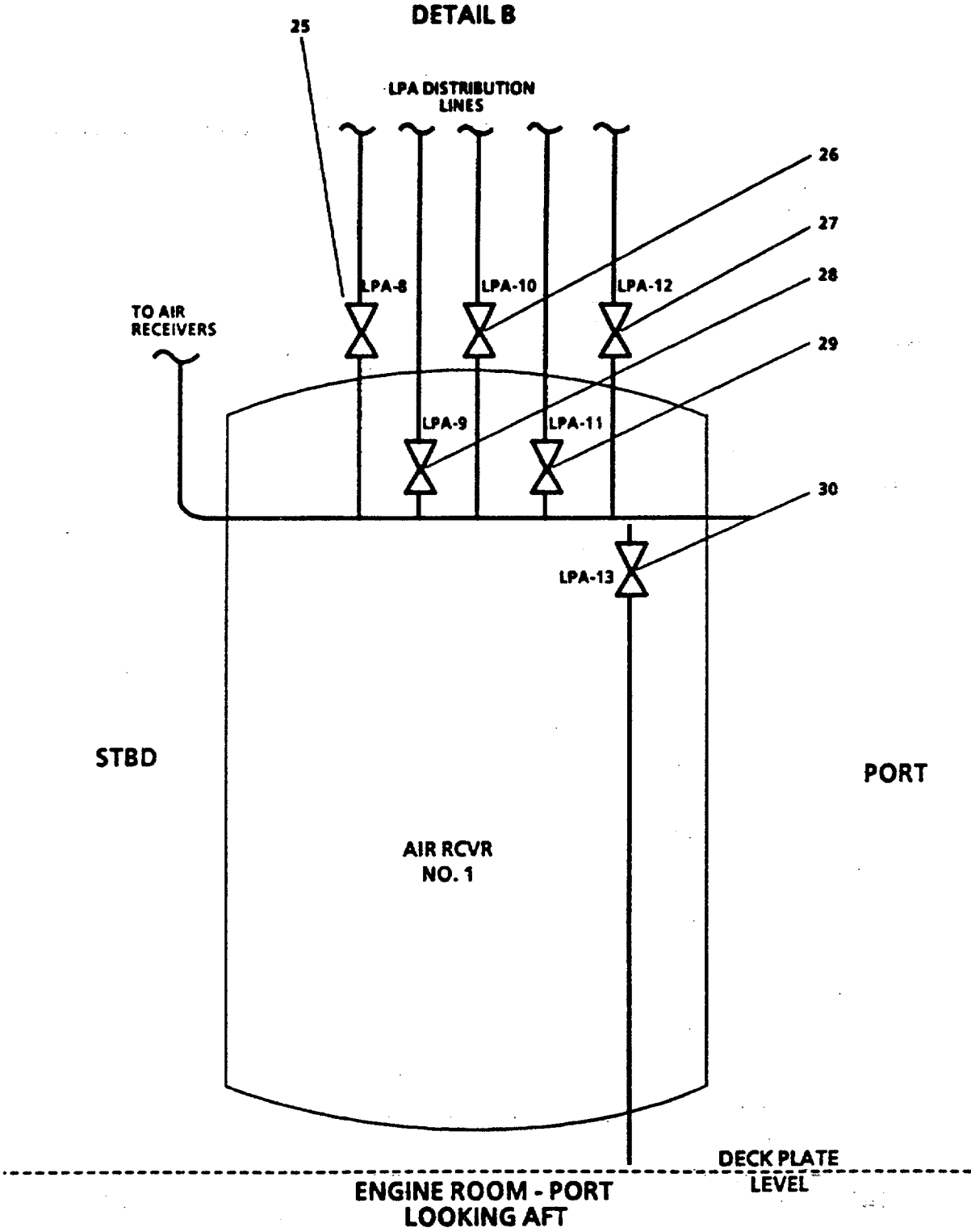

FIGURE 1-104. Compressed Air Piping System (Sheet 3 of 5)

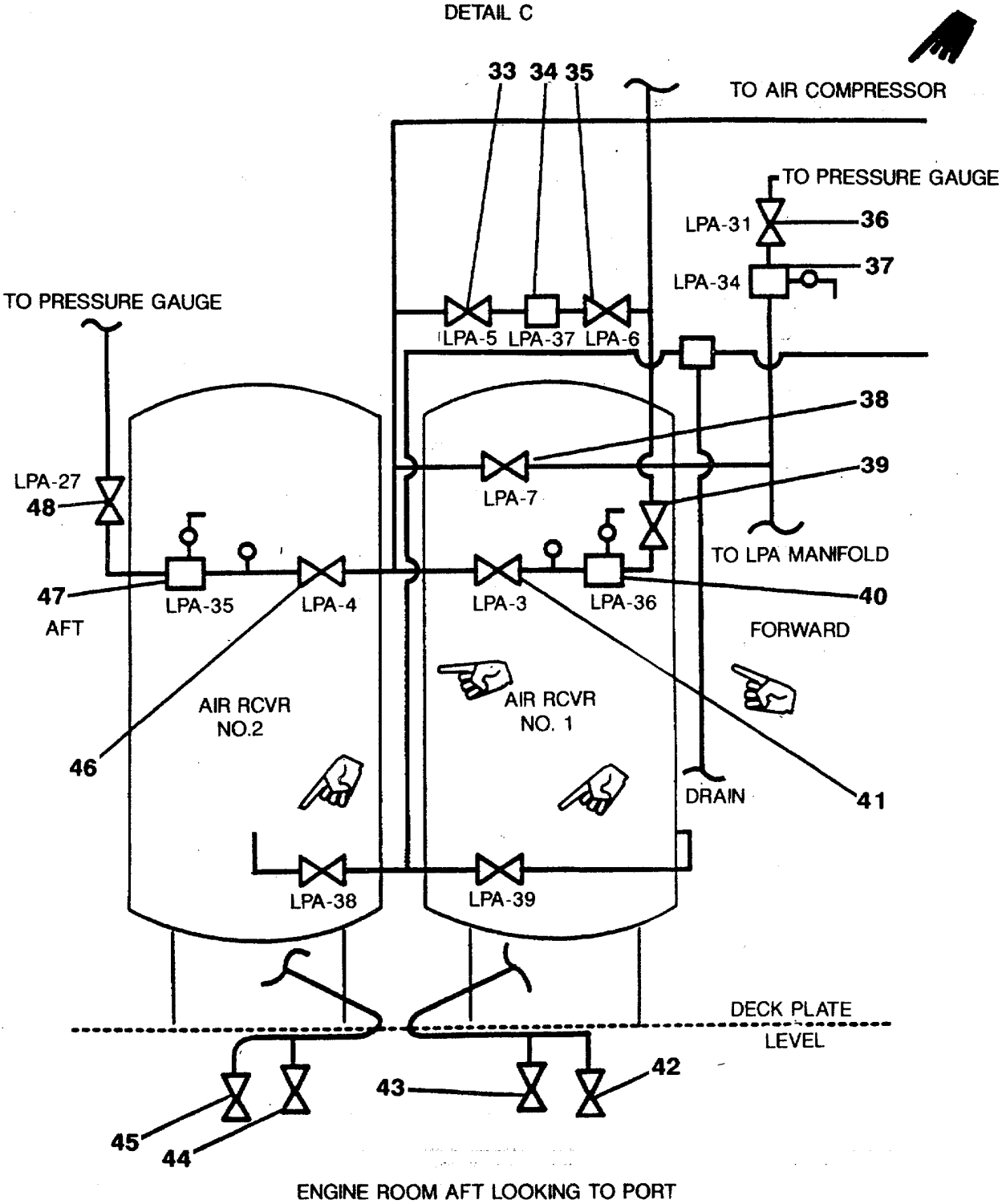

FIGURE 2-104. Compressed Air Piping System (Sheet 4 of 5).

LEGEND

- |  |   |
|--|---|
| 1. LPA-26, SUPPLY TO SVCE AIR          | 26 LPA-10, SUPPLY TO MN ENG-STBD        |
| 2. LPA-24, SEA CHEST BLWDN             | 27 LPA-12, SUPPLY TO SSDG-PORT          |
| 3. LPA-25, SUPPLY TO SVCE AIR          | 28 LPA-9, SUPPLY TO SVCE AIR            |
| 4. LPA-23, SUPPLY TO FWD SVCE AIR      | 29 LPA-11, SUPPLY TO MN ENG-PORT        |
| 5. LPA-21, SUPPLY TO FWD SVCE AIR      | 30 LPA-13, MANIFOLD DRAIN               |
| 6. LPA-22, SUPPLY TO SVCE AIR          | 31 LPA-29, TO AIR CPRSR UNLOADERS       |
| 7. LPA-19, SEA CHEST BLWDN             | 32 LPA-30, PRESS SW                     |
| 8. LPA-15, SUPPLY TO MN ENG-STBD       | 33 LPA-5, SUPPLY TO PRESS RDCR          |
| 9. LPA-17, SUPPLY TO SVCE AIR          | 34 LPA-37, PRESS RDCR                   |
| 10. LPA-16, SUPPLY TO MN ENG-PORT      | 35 LPA-6, SUPPLY TO MANIF               |
| 11. LPA-18, SUPPLY TO SSDG-PORT        | 36 LPA-31, PRESS GAGE                   |
| 12. LPA-14, SUPPLY TO SVCE AIR         | 37 LPA-34, RELIEF VLV                   |
| 13. LPA-20, SUPPLY TO SVCE AIR         | 38 LPA-7, BYPASS TO MANF                |
| 14. CA-1, CONTROL AIR CUTOUT           | 39 LPA-28, PRESS GAGE-AIR RCVR NO. 1    |
| 15. LPA-32, RELIEF VLV-AIR CPRSR NO.1  | 40 LPA-36, RELIEF VLV-AIR RCVR NO. 1    |
| 16. LPA-1, DISCH-AIR CPRSR NO. 1       | 41 LPA-3, ISLN-AIR RCVR NO. 1           |
| 17. CA-2, ISLN-SEP/RGLTR               | 42 AIR RECEIVER DRAIN                   |
| 18. CA-3, SEP/RGLTR                    | 43 ISOLATION VALVE-AIR WATER SEPARATOR  |
| 19. CA-4, SUPPLY TO CONTROL AIR        | 44 ISOLATION VALVE-AIR WATER SEPARATOR  |
| 20. CA-7, SUPPLY TO CONTROL AIR        | 45 AIR RECEIVER DRAIN -                 |
| 21. CA-6, SEP/RGLTR                    | 46 LPA-4, ISLN-AIR RCVR NO. 2           |
| 22. CA-5, ISLN-SEP/RGTR                | 47 LPA-35, RELIEF VLV-AIR RCVR NO. 2    |
| 23. LPA-2, DISCH-AIR CPRSR NO. 2       | 48 LPA-27, PRESS GAGE-AIR RCVR NO. 2    |
| 24. LPA-33, RELIEF VLV-AIR CPRSR NO. 2 | 49 LPA-38, SUPPLY TO AIR RECEIVER NO. 2 |
| 25. LPA-8, SUPPLY TO CONTROL AIR       | 50 LPA-39, SUPPLY TO AIR RECEIVER NO.1  |

FIGURE 2-104. Compressed Air Piping System (Sheet 5 of 5).

Change 2 2-329



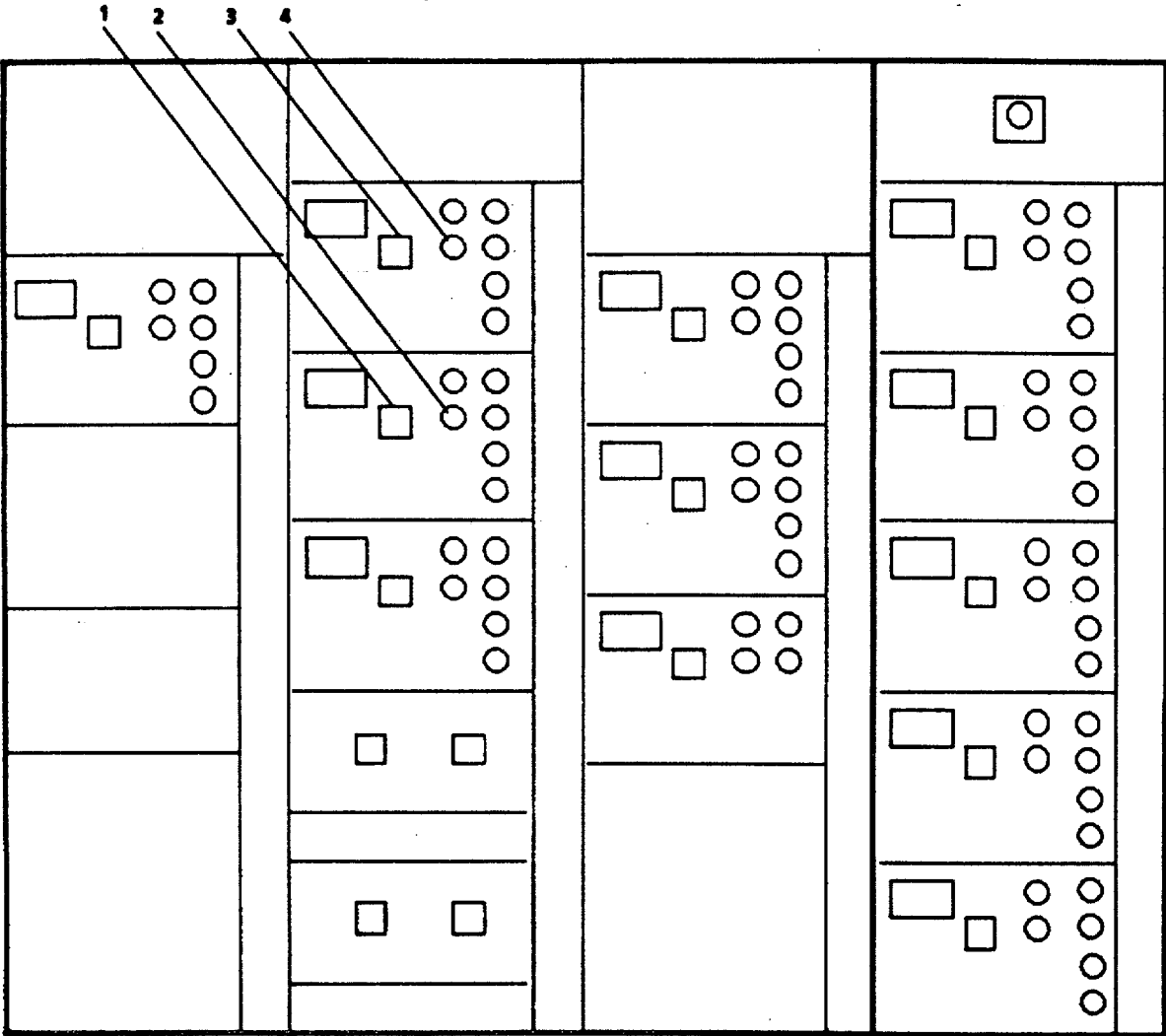

- LEGEND**
- 1. AIR COMPRESSOR NO. 2 (P205-11)
  - 2. START
  - 3. AIR COMPRESSOR NO. 1 (P205-10)
  - 4. START

FIGURE 2-105. Auxiliary Machinery Motor Control Center.

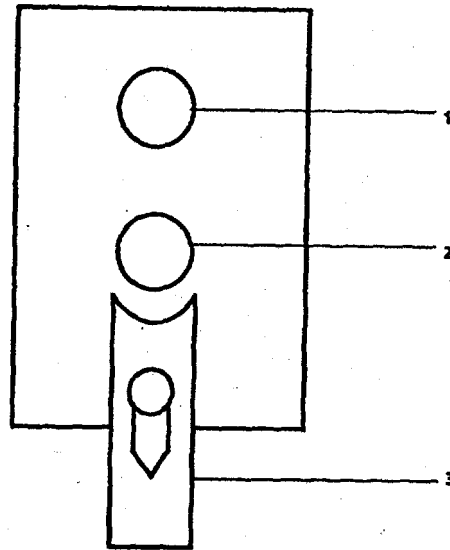

**LEGEND**  
 1. START  
 2. STOP  
 3. LOCK

FIGURE 2-106. TYPE-I Motor Switch.

- (2) Open CA-1, CONTROL AIR CUTOUT (14).
- (3) Set power switch on air dryer to ON position.
- (4) Open CA-2 and CA-5, ISLN-SEP/RGLTR (17 and 22).
- (5) Open CA-4 AND CA-7, SUPPLY TO CONTROL AIR (19 and 20).

## 2-9. Life Support System.

### a. Ventilation.

- (1) On Engine Room Ventilation Motor Control Center (FIGURE 2-107), set ENGINE ROOM EXHAUST FAN circuit breaker P210-3 (4) to ON position, press START pushbutton (3).
- (2) Set ENGINE ROOM EXHAUST FAN circuit breaker P210-4 (1).to ON position, press START pushbutton (2).
- (3) Set ENGINE ROOM SUPPLY FAN circuit breaker P210-2 (8) to ON position, press LOW pushbutton (7).
- (4) Set ENGINE ROOM SUPPLY FAN circuit breaker P210-1 (6) to ON position, press LOW pushbutton (5).

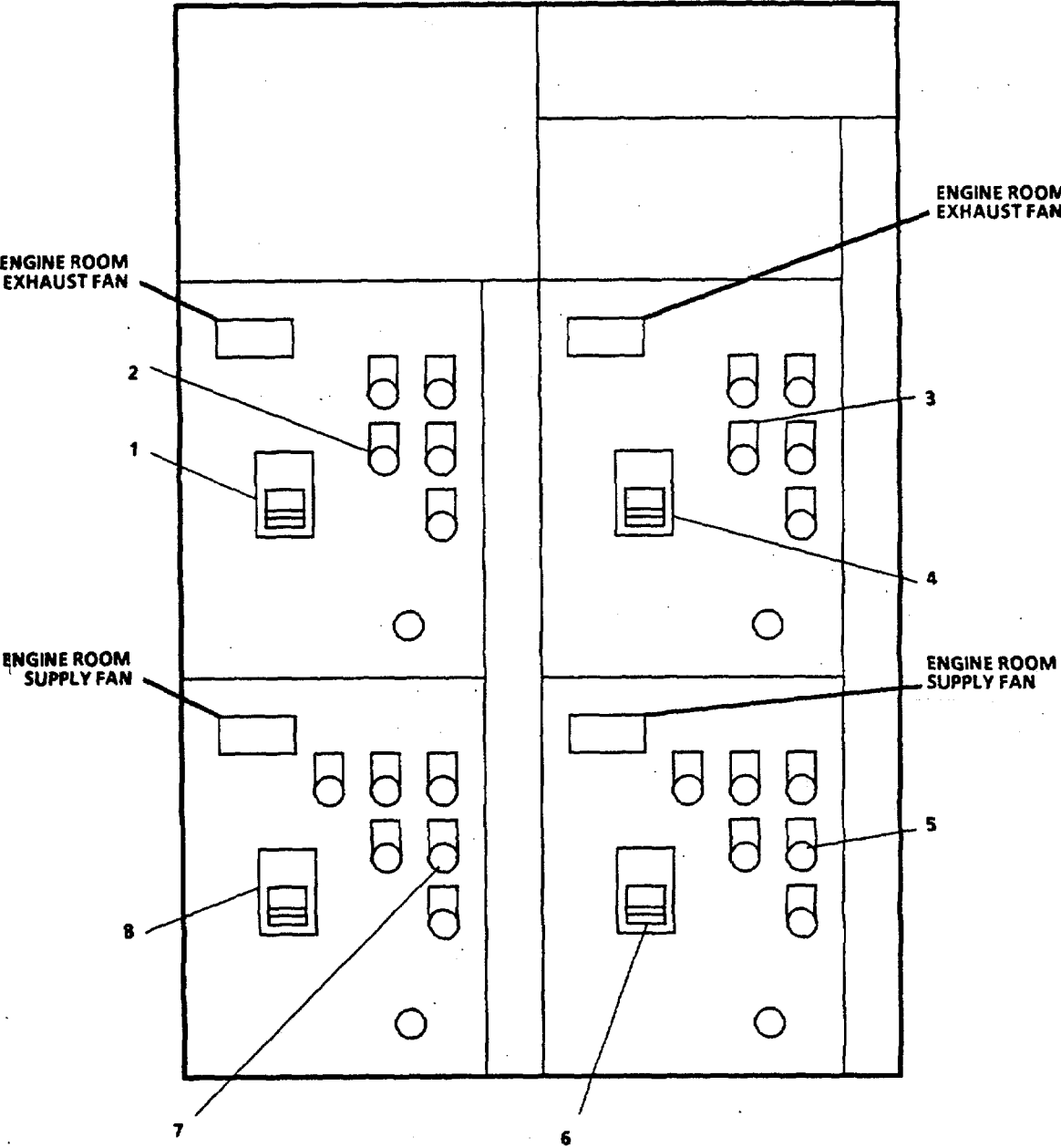

**LEGEND**

- 1. P210-4
- 2. START PUSHBUTTON
- 3. START PUSHBUTTON
- 4. P210-3
- 5. LOW PUSHBUTTON
- 6. P210-1
- 7. LOW PUSHBUTTON
- 8. P210-2

FIGURE 2-107. Engine Room Ventilation Motor Control Center.

## b. Air Conditioning.

## NOTE

On High Voltage Air Conditioning unit set control switch to heater operation.

- (1) Align Sea Water Cooling Piping System (FIGURE 2-108) as follows:
  - (a) Open SW-1, SUPPLY TO PUMP (3).
  - (b) Open SW-2, PRESSURE GAUGE SUPPLY TO STRAINER (4).
  - (c) Open SW-3, PUMP SUCTION (5).
  - (d) Open SW-4, PRESS GAUGE PUMP SUCTION (6).
  - (e) Open SW-5, PRESS GAUGE PUMP DISCH (2).
  - (f) Open SW-6, PUMP DISCH (8).
  - (g) Open SW-15, SUPPLY TO PRESS SWITCH (20).
  - (h) Open SW-17, SUPPLY TO AIR COND UNIT (17).
  - (i) Open SW-18, DISCH FROM AIR COND UNIT (16).
  - (j) Open SW-16 BY-PASS valve (18).
  - (k) Open SW-28, OVBD DISCH FR AIR COND UNIT (21).
  - (l) Open SW-7, SUPPLY TO AIR COND UNIT (24).
  - (m) Open SW-8, BY-PASS valve (22).
  - (n) Open SW-13, ISLN-STBD STERN TUBE (11).
  - (o) Open SW-11, SUPPLY TO STBD STERN TUBE (12).
  - (p) Open SW-10, SUPPLY TO PORT STERN TUBE (13).
  - (q) Open SW-12, ISLN-TO PORT STERN TUBE (15).
  - (r) Open SW-14, ISLN-MSD (9).
  - (s) Open SW-20, ISLN TO AIR COND UNIT (26).
  - (t) Open SW-21, BY-PASS valve (27).
  - (u) Open BB-35 SEACHEST VENT ISOLATION and BB-36 SEACHEST VENT.
- (2) At Auxiliary Machinery Motor Control Center (FIGURE 2-109), set A.C.S.W. COOLING PUMP circuit breaker (1) to ON position.

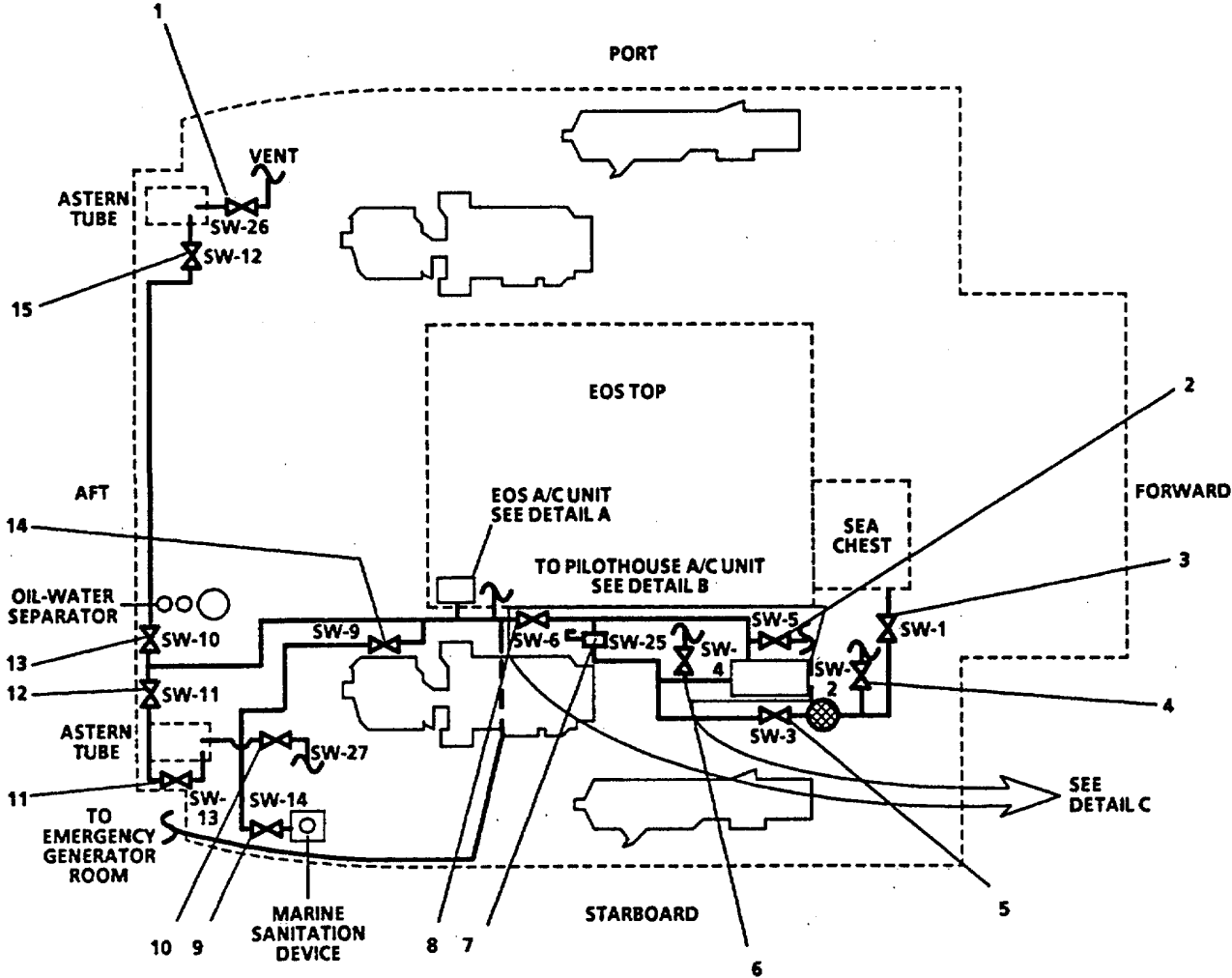
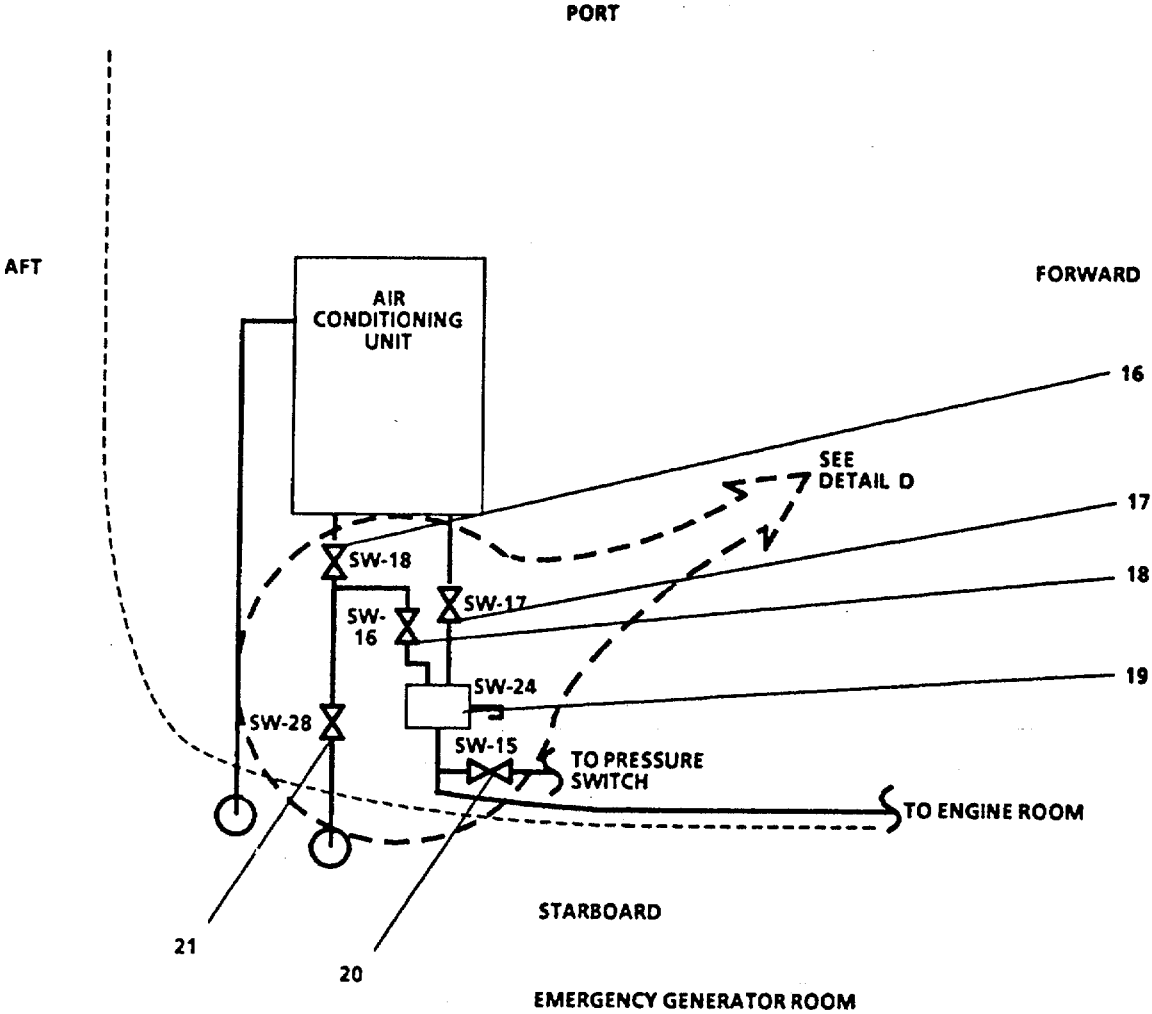
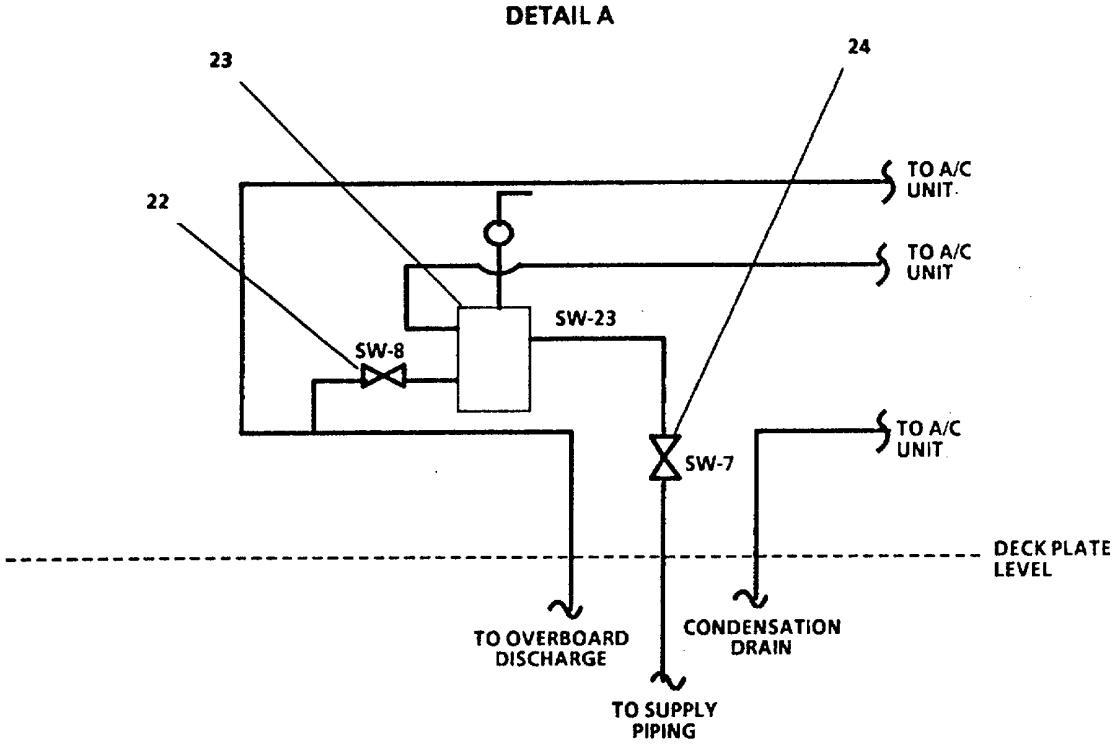

FIGURE 2-108. Sea Water Cooling Piping System (Sheet 1 of 5).



**NOTE:** SW-28 IS CONTROLLED FROM THE MAIN DECK STBD IN DECK ONLY. SW-28 IS PHYSICALLY LOCATED IN TANK SW-85

FIGURE 2-108. Sea Water Cooling Piping System (Sheet 2 of 5).



**EOS A/C UNIT  
(LOCATED IN EOS NEAR AIR HANDLING UNIT)**

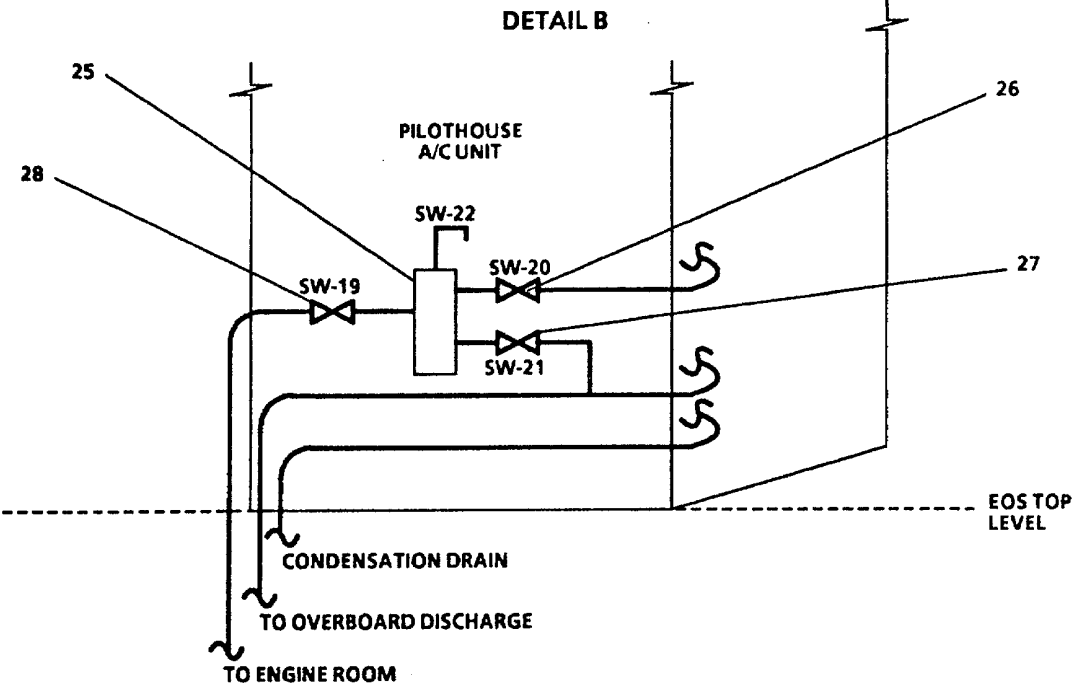

**PILOTHOUSE A/C UNIT**

FIGURE 2-108. Sea Water Cooling Piping System (Sheet 3 of 5).

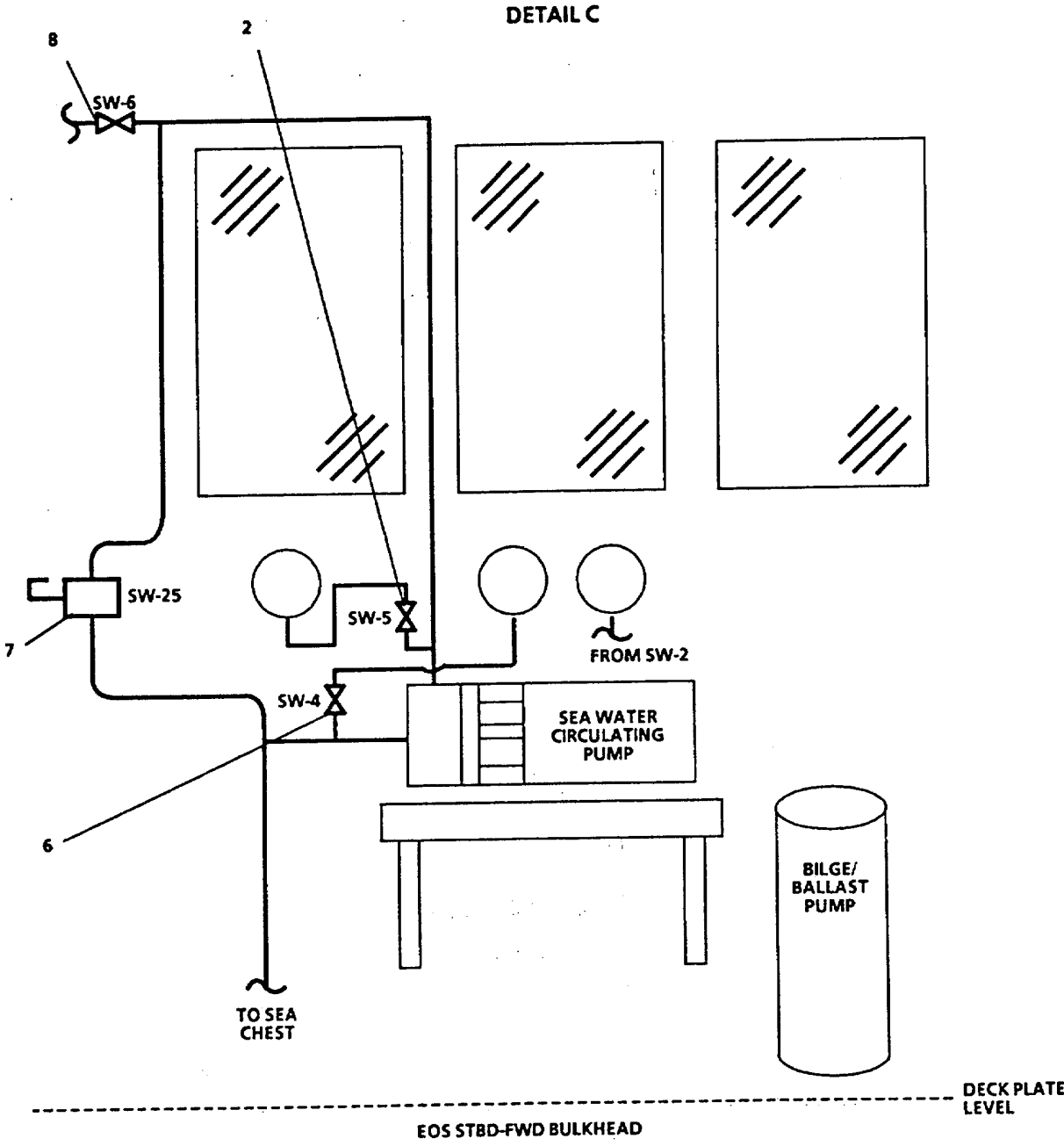
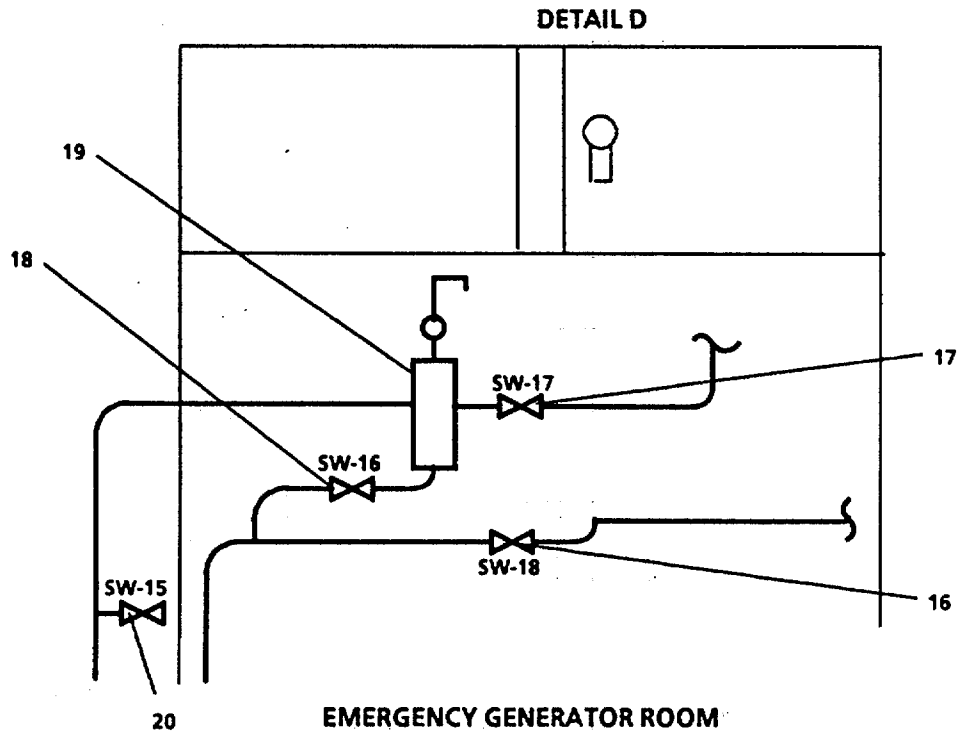

FIGURE 2-108. Sea Water Cooling Piping System (Sheet 4 of 5).





LEGEND

- |  |  |
|--|--|
| 1. SW-26, VENT-PORT STERN TUBE         | 15. SW-12, ISLN-PORT STERN TUBE        |
| 2. SW-S, PRESS GAGE PUMP DISCH         | 16. SW-18, DISCH FORM AIR COND UNIT    |
| 3. SW-1, SUPPLY TO PUMP                | 17. SW-17, SUPPLY TO AIR COND UNIT     |
| 4. SW-2, PRESS GAGE SUPPLY TO STRAINER | 18. SW-16, BY-PASS                     |
| 5. SW-3, PUMP SUCTION                  | 19. SW-24, REGULATING VALVE            |
| 6. SW-4, PRESS GAGE PUMP SUCTION       | 20. SW-15, SUPPLY TO PRESS SWITCH      |
| 7. SW-25, RELIEF VALVE SET AT 55 PSI   | 21. SW-28, OVBD DISCH FR AIR COND UNIT |
| 8. SW-6, PUMP DISCH                    | 22. SW-8, BY-PASS                      |
| 9. SW-14, ISOLATION-MSD                | 23. SW-23, REGULATING VALVE            |
| 10. SW-27, VENT-STBD STERN TUBE        | 24. SW-7, SUPPLY TO AIR COND UNIT      |
| 11. SW-13, ISLN-STBD STERN TUBE        | 25. SW-22, REGULATING VALVE            |
| 12. SW-11, SUPPLY TO STBD STERN TUBE   | 26. SW-20, ISLN TO AIR COND UNIT       |
| 13. SW-10, SUPPLY TO PORT STERN TUBE   | 27. SW-21, BY-PASS                     |
| 14. SW-9, SUPPLY TO MSD                | 28. SW-19, SUPPLY TO AIR COND UNIT     |

FIGURE 2-108. Sea Water Cooling Piping System (Sheet 5 of 5).

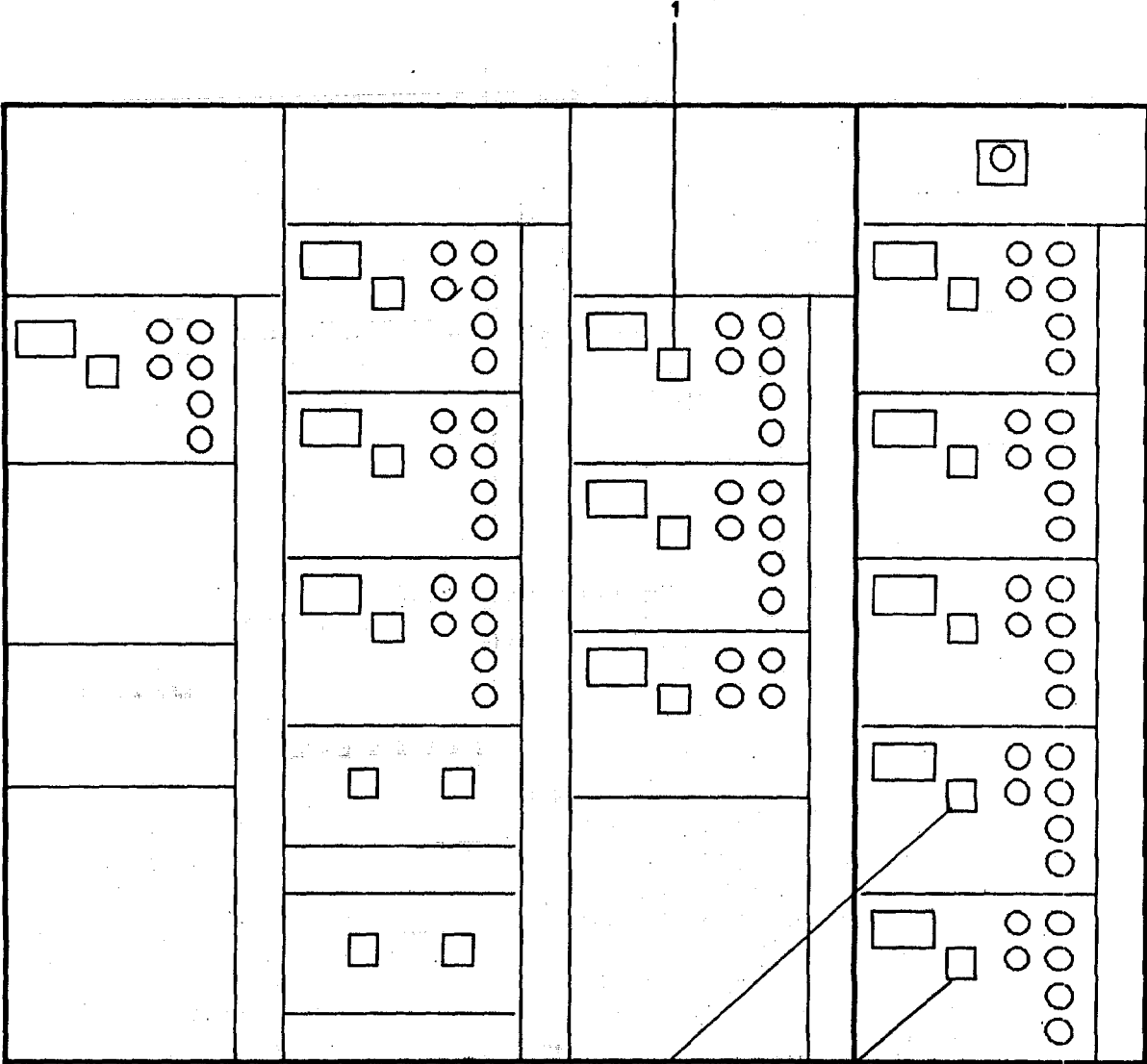

**LEGEND**

- 1. A.C.S.W. COOLING PUMP (P205-1)
- 3. FRESH WATER PUMP NO. 2 (P205-5)
- 3. FRESH WATER PUMP NO. 1 (P205-4)

FIGURE 2-109. Auxiliary Machinery Motor Control Center.

- (3) At cooling pump TYPE-I Motor Switch (FIGURE 2-106):
  - (a) Release STOP button (2) by sliding LOCK (3) down.
  - (b) Press START button (1).
- (4) On Main Switchboard (FIGURE 2-110), set ACCOMMODATION A/C UNIT circuit breaker (1) to ON position.
- (5) At 15 TON A/C MOTOR CONTROLLER (FIGURE 2-111), set RESET/OFF/ON switch (1) to RESET and to ON position. Set FAN/OFF/COMPRESSOR switch (2) to COMPRESSOR position.
- (6) In Engine Room Operating Station:
  - (a) Set thermostat to desired temperature position.
  - (b) Set fan ON-OFF switch to desired position.
- (7) In Pilothouse:
  - (a) Set thermostat to desired temperature position.
  - (b) Set fan ON-OFF switch to desired position.

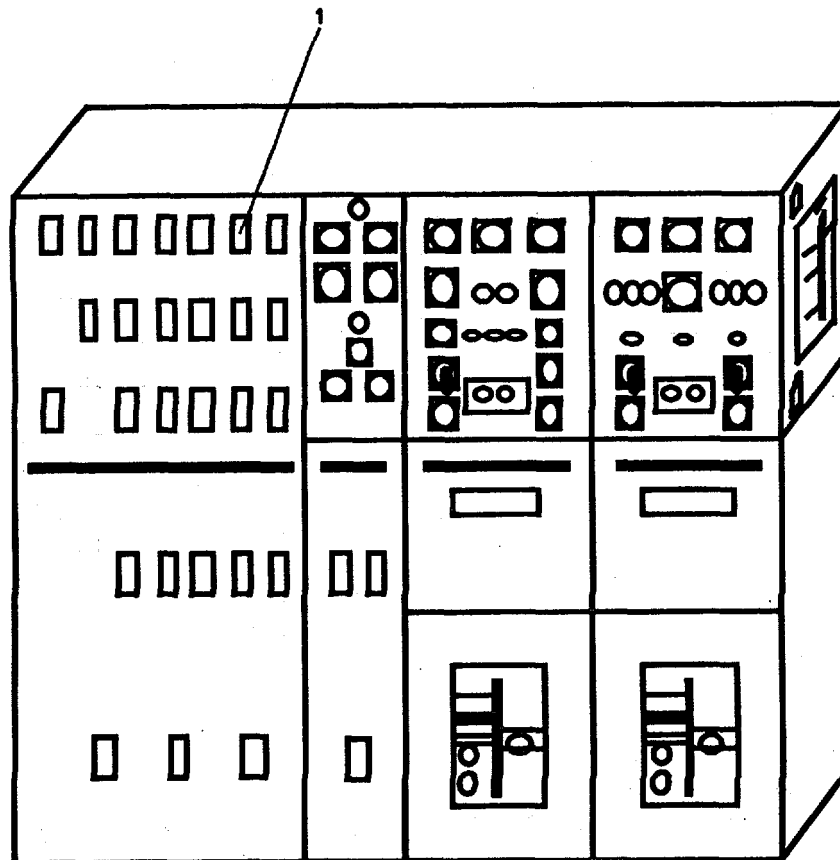

**LEGEND**

1. ACCOMODATIONS A/C UNIT

FIGURE 2-110. Main Switchboard.

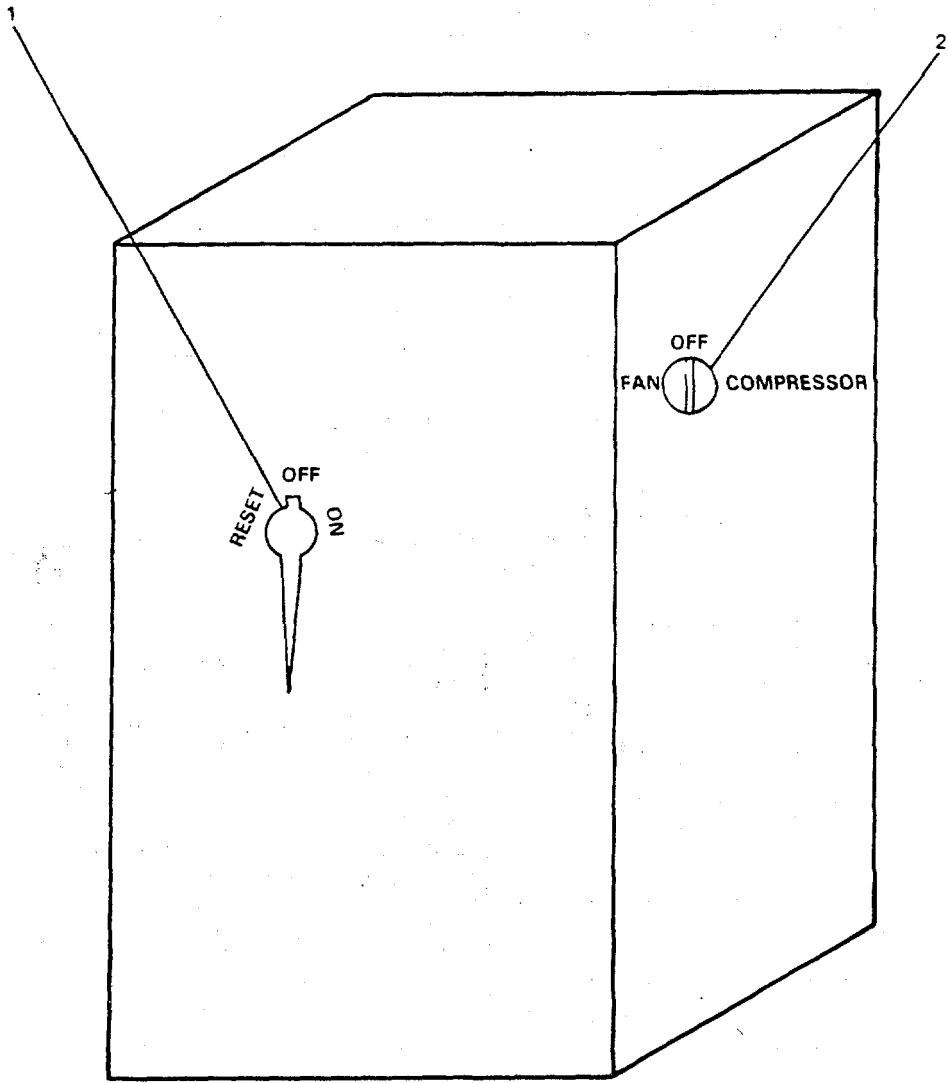

**LEGEND**

1. RESET/OFF/ON CONTROL

2. FAN/OFF/COMPRESSOR CONTROL

FIGURE 2-111. 15 Ton A/C Motor Controller.  
2-341

c. Fresh Water Piping System (FIGURE 2-112).

- (1) Align Fresh Water Piping System at the fresh water (FW) tanks and pumps as ½\_, follows:
- (a) Open FW-8, ISNL/SUCT-TK FW-6P (4).
  - (b) Open FW-7, ISLN/SUCT-TK FW-6S (8).
  - (c) Open FW-10, FW PUMP NO. 2 SUCT FR FW TKS (26).
  - (d) Open FW-9, FW PUMP NO. 1 SUCT FR FW TKS (24).
  - (e) Open FW-12, FW PUMP No. 2 DISCH (19).
  - (f) Open FW-11, FW PUMP No. 1 DISCH from Pump (25).
  - (g) Open FW-13, PRESSURE ISLN (20).

**NOTE**

In fresh water piping systems all other valves are for equipment repair or fresh water use.

- (2) In Engine Room at Fresh Water Motor Controllers (FIGURE 2-113) perform the following:

(a) P217 Motor Controller.

1 Set circuit breaker HANDLE (1) to ON position.

\_\_\_ 2 Set HAND-OFF-AUTO switch (2) to AUTO position.

\_\_\_ 3 Press START (3) pushbutton.

(b) P218 Motor Controller.

\_\_\_ 1 Set circuit breaker HANDLE (1) to ON position.

\_\_\_ 2 Set HAND-OFF-AUTO switch (2) to AUTO position.

\_\_\_ 3 Press START (3) pushbutton.

d. Water Purification System.

- (1) Align Fresh Water Piping System (FIGURE 2-112) as follows:

(a) Open BB-22, ISLN SEACHEST.

(b) Open BB-35 SEACHEST VENT ISOLATION and BB-36 SEACHEST VENT.

(c) Open FWM-1, ISLN-SW SUPPLY TO FW MAKERS (11).

(d) Open FWM-2, SW SUPPLY TO FW MAKER NO. 2 (14).

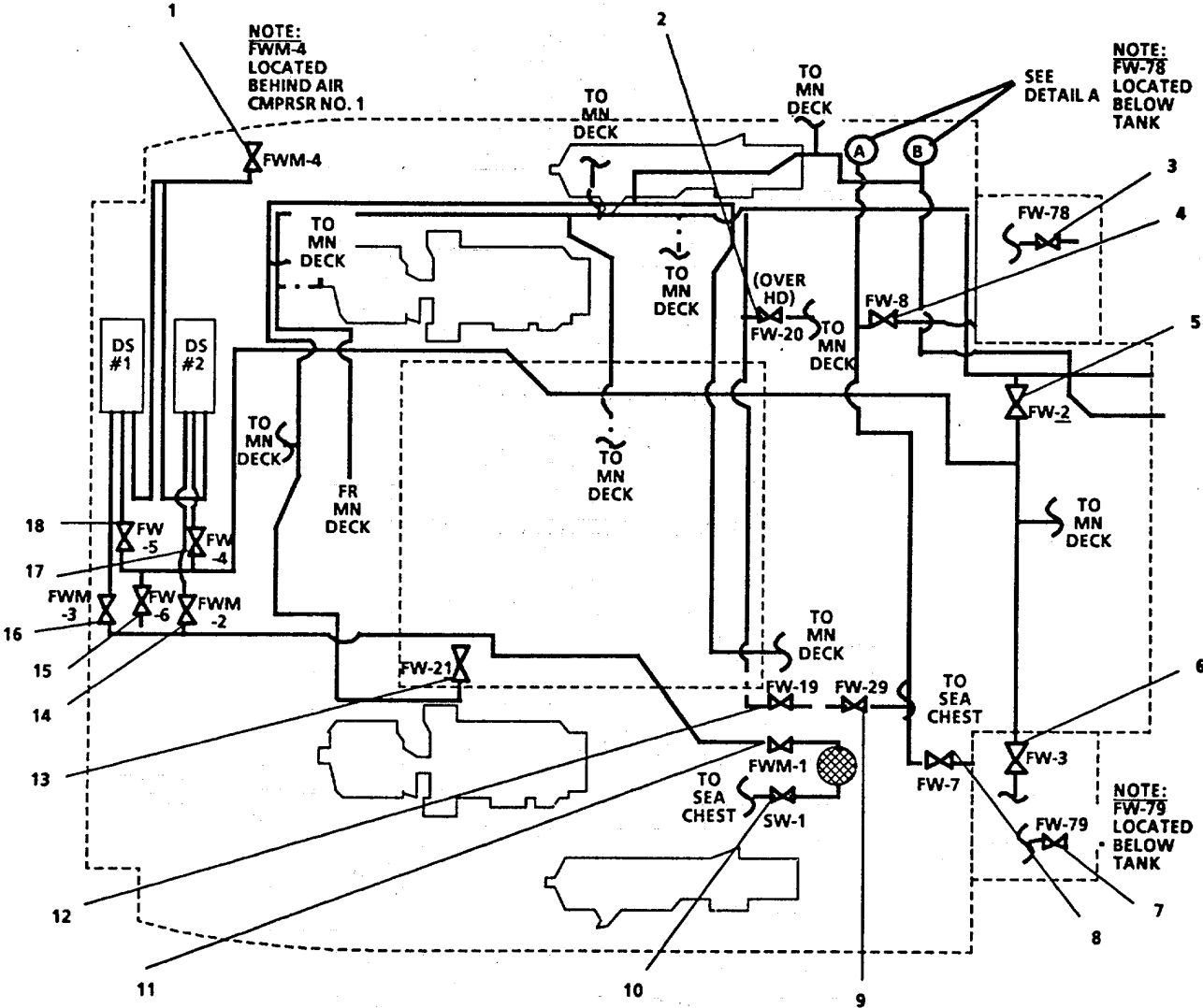

FIGURE 2-112. Fresh Water Piping System (Sheet 1 of 8).  
2-343

DETAIL A

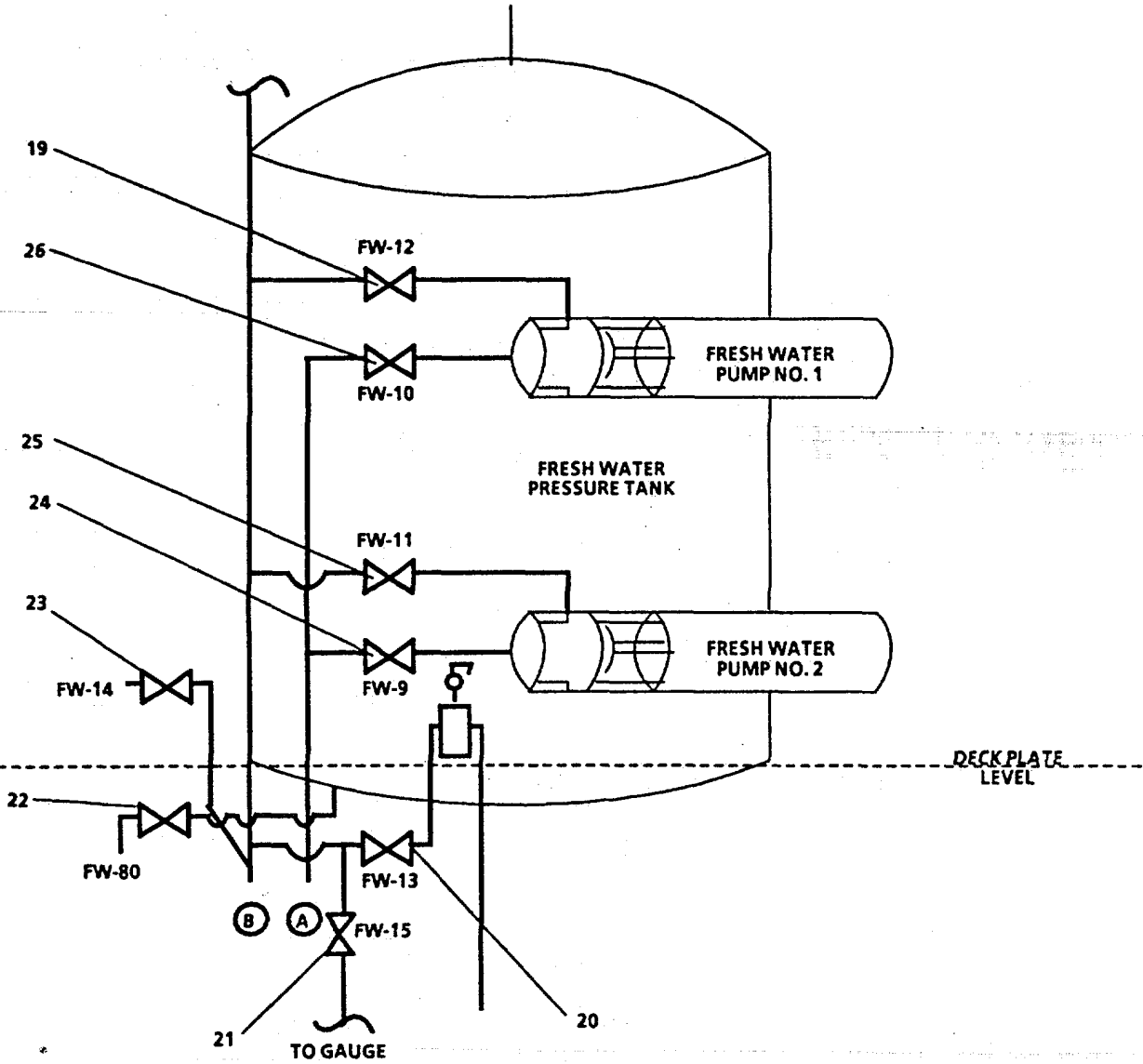

FIGURE 2-112. Fresh Water Piping System (Sheet 2 of 8).  
2-344

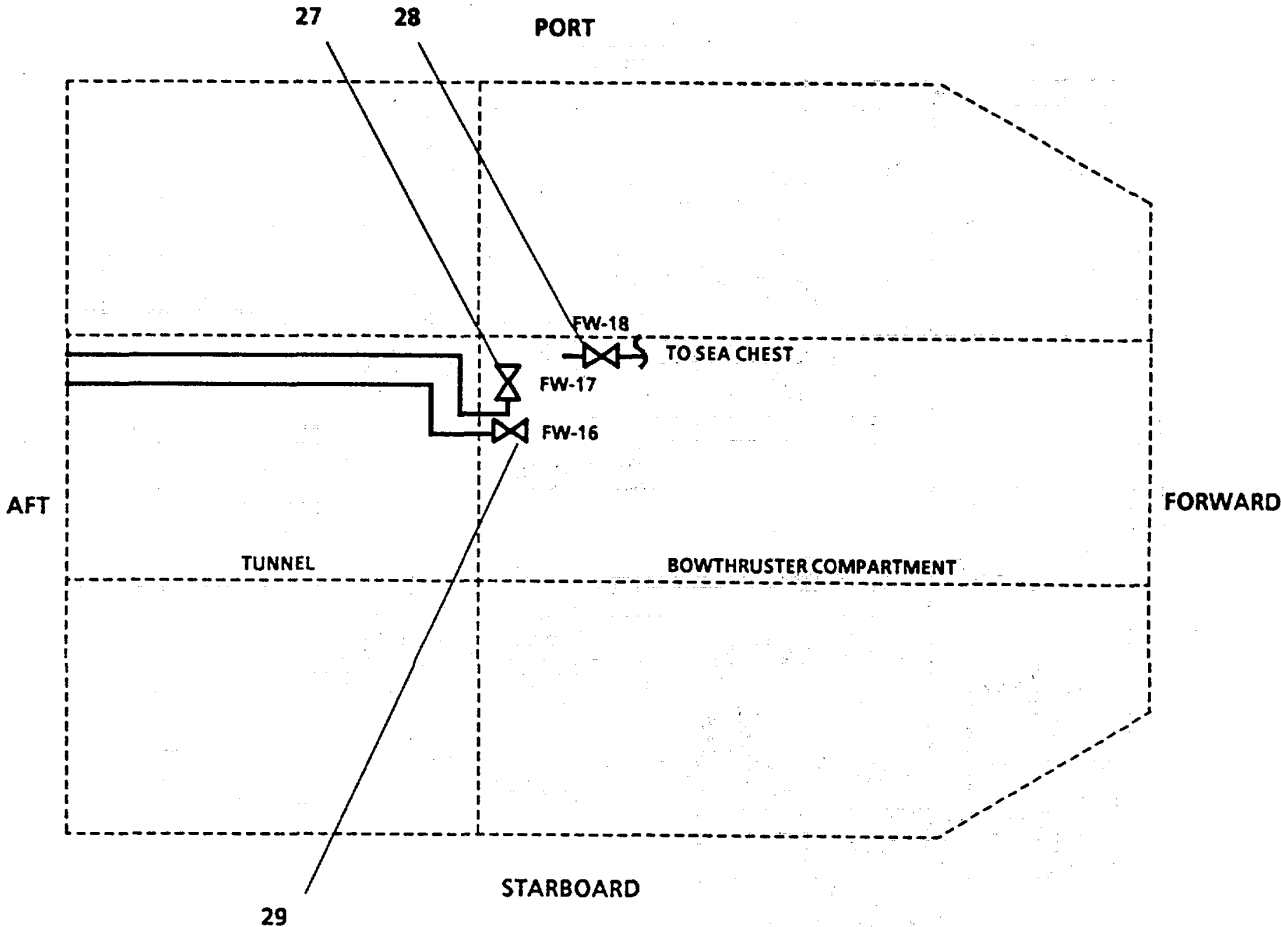

FIGURE 2-112. Fresh Water Piping System (Sheet 3 of 8).



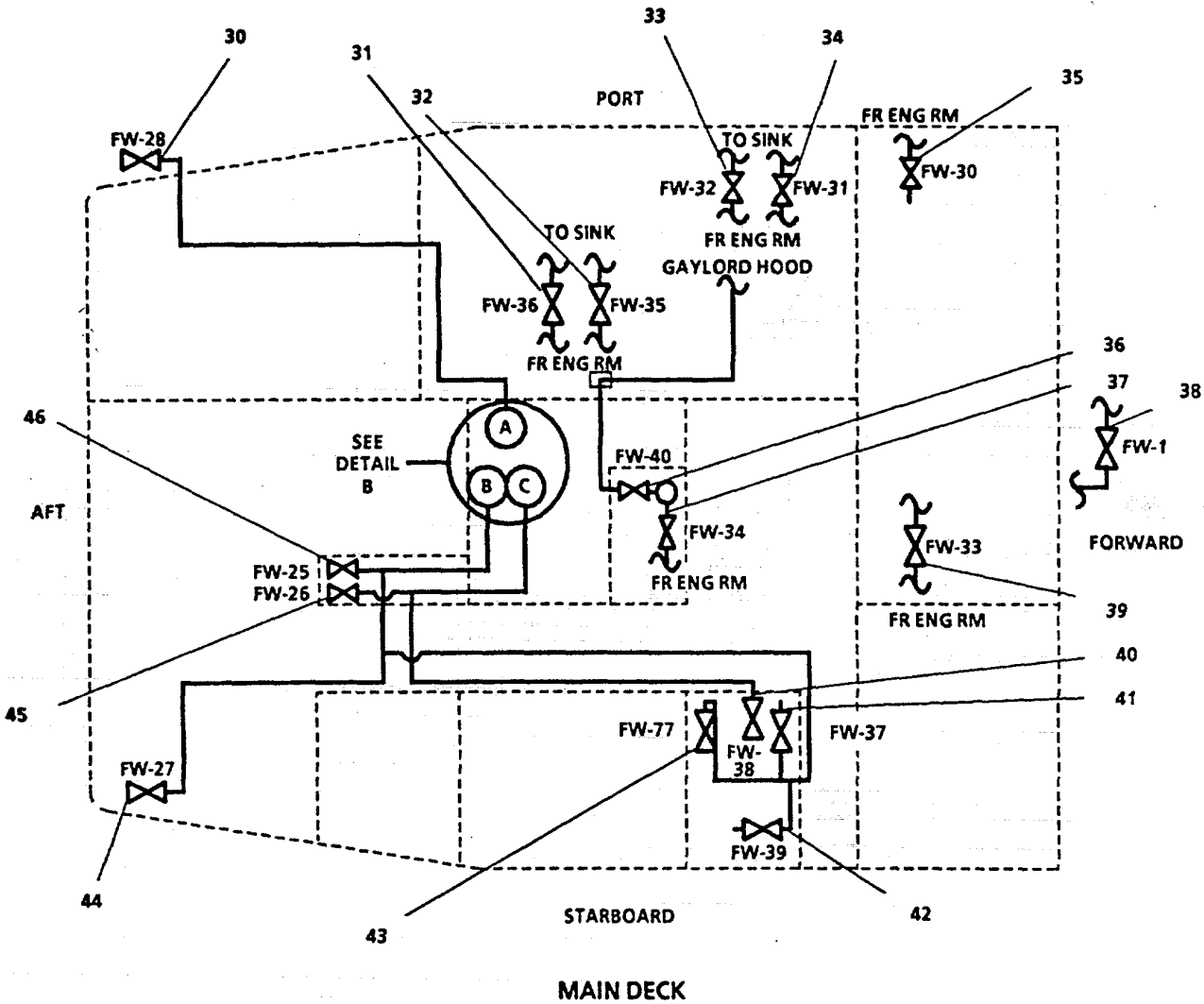

FIGURE 2-112. Fresh Water Piping System (Sheet 4 of 8).

DETAIL B

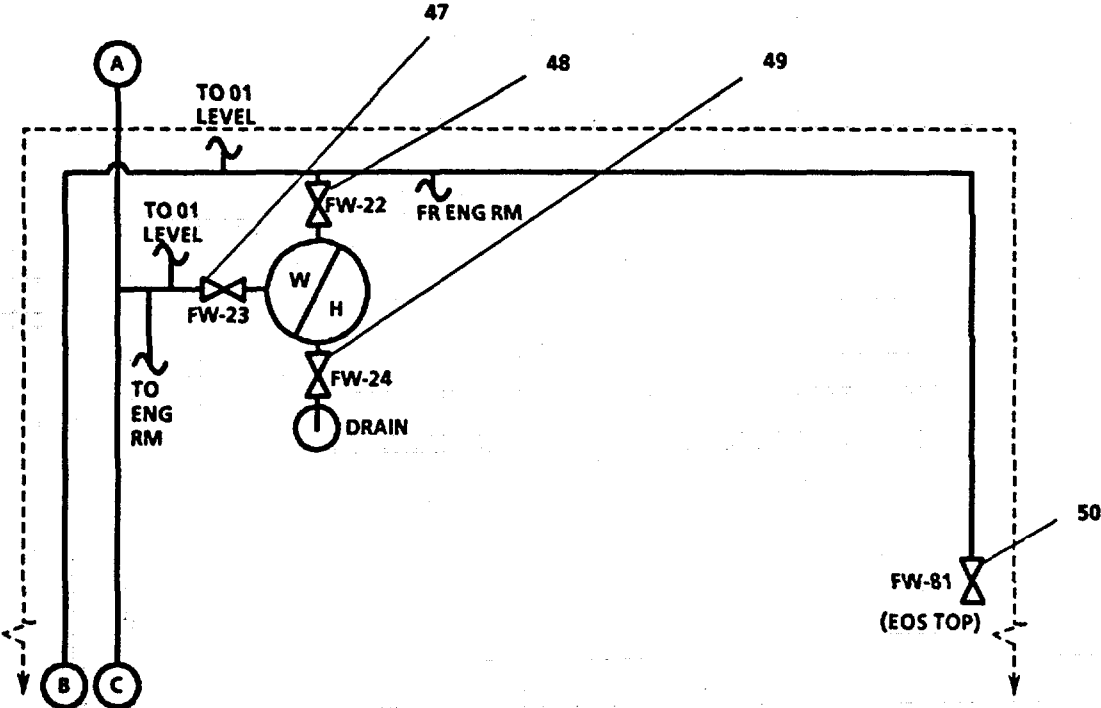

FIGURE 2-112. Fresh Water Piping System (Sheet 5 of 8).

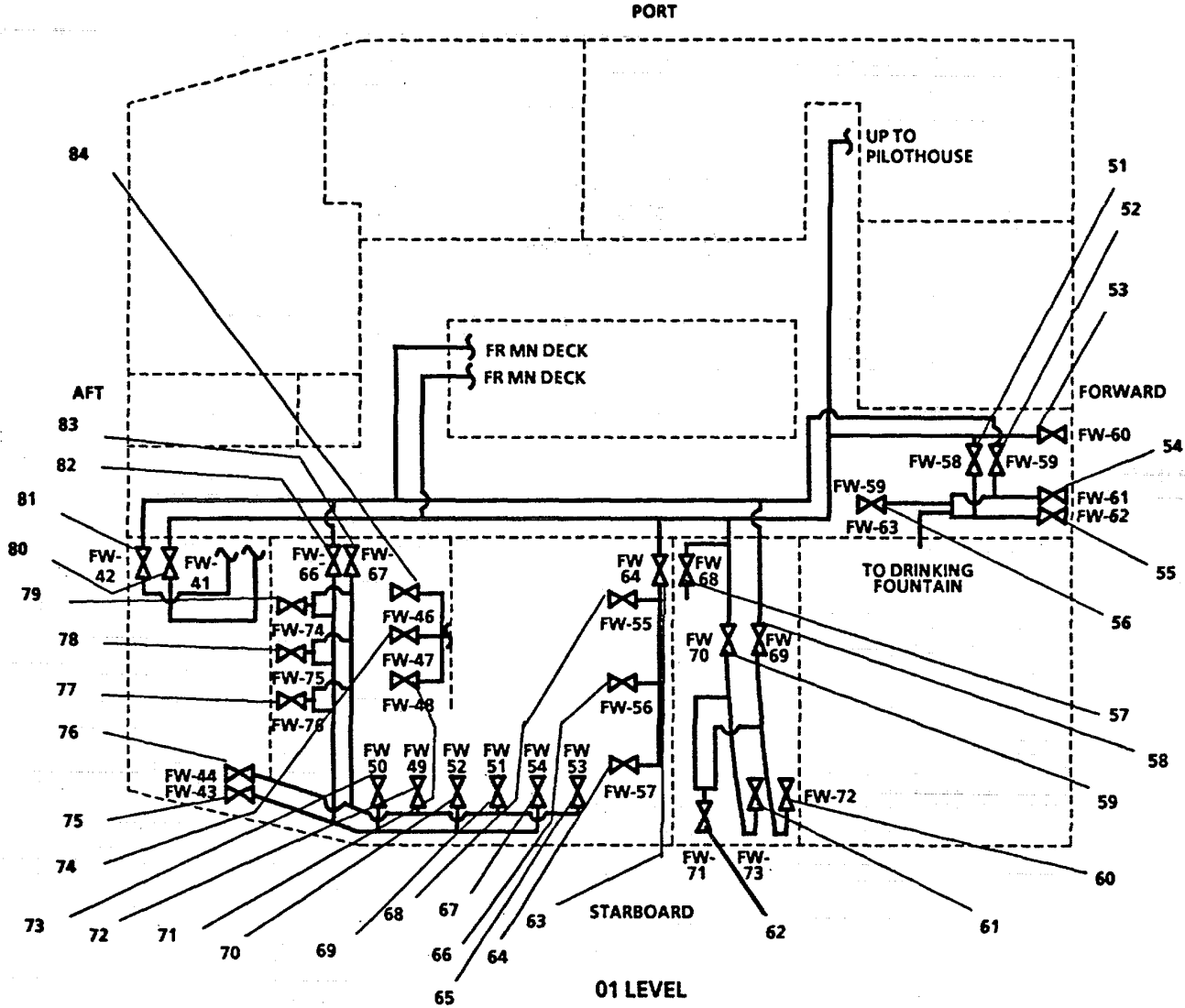
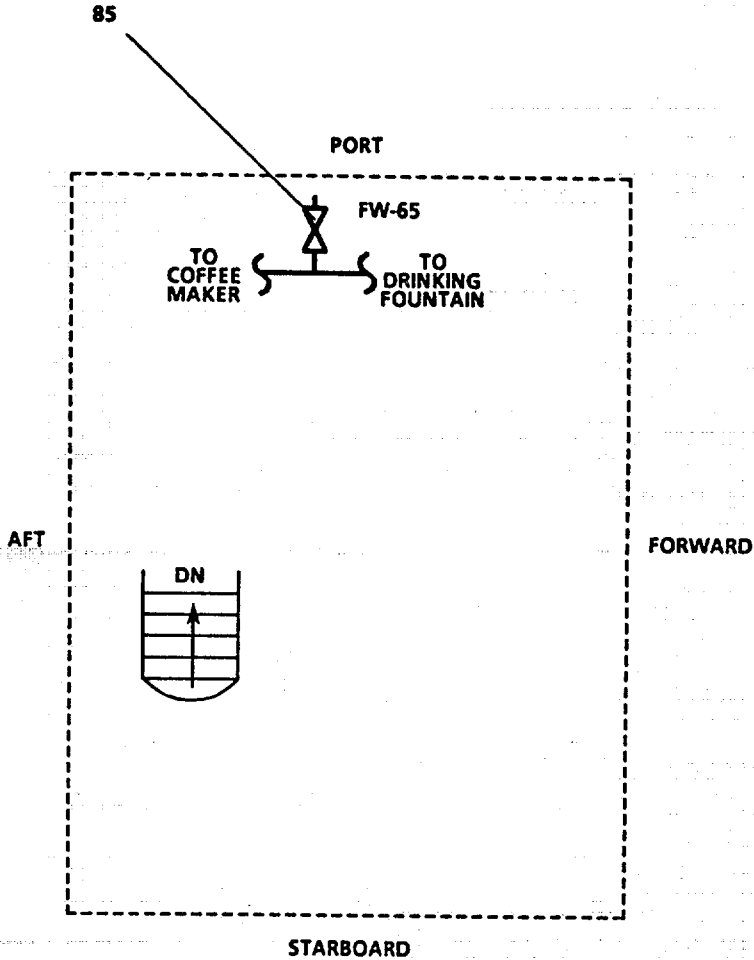

FIGURE 2-112. Fresh Water Piping System (Sheet 6 of 8).  
2-348



**PILOTHOUSE**

FIGURE 2-112. Fresh Water Piping System (Sheet 7 of 8)

**LEGEND**

- |   |                                    |
|---|------------------------------------|
| 1. FWM-4, BRINE OVBD DISCH                          | 44. FW-27, COLD FW HOSE CONN       |
| 2. FW-20, HOT FW TO DISHWASHER                      | 45. FW-26, HOT FW TO CG LKR SINK   |
| 3. FW-78, DRAIN-TK FW-6P                            | 46. FW-25, COLD FW TO CG LKR SINK  |
| 4. FW-8, ISLN/SUCT-TK FW-6P                         | 47. FW-23, HOT FW DISCH FR WTR HTR |
| 5. FW-2, FILL ISLN-TK FW-6P                         | 48. FW-22, COLD FW TO WTR HTR      |
| 6. FW-3, FILL ISLN-TK FW-6S                         | 49. FW-24, WTR HTR DRAIN           |
| 7. FW-79, DRAIN-TK FW-6S                            | 50. FW-81, EXP TK FILL             |
| 8. FW-7, ISLN/SUCT-TK FW-6S                         | 51. FW-58, COLD FW ISLN            |
| 9. FW-29, SEA CHEST-HOT FW CONNECTION               | 52. FW-59, HOT FW ISLN             |
| 10. SW-1, SUPPLY TO PUMP                            | 53. FW-60, SUPPLY TO WC            |
| 11. FWM-1, ISLN-SW SUPPLY TO FW MAKERS              | 54. FW-61, SUPPLY TO WC            |
| 12. FW-19, HOT FW HOSE CONN                         | 55. FW-62, COLD FW TO SINK         |
| 13. FW-21, COLD FW TO DF & COFFEE MAKER-ENG RM      | 56. FW-63, SUPPLY TO SH            |
| 14. FWM-2, SW SUPPLY TO FW MAKER NO. 2              | 57. FW-68, SUPPLY TO WC            |
| 15. FW-6, FW SAMPLE STA                             | 58. FW-69, COLD FW ISLN            |
| 16. FWM-3, SW SUPPLY TO FW MAKER NO. 1              | 59. FW-70 ISLN-HOT FW              |
| 17. FW-4, FW MAKER NO. 2 SUPPLY TO FW TKS           | 60. FW-72 COLD FW TO SINK          |
| 18. FW-5, FW MAKER NO. 1 SUPPLY TO FW TKS           | 61. FW-73 HOT FW TO SINK           |
| 19. FW-12, FW PUMP NO. 2 DISCH                      | 62. FW-71 SUPPLY TO SH             |
| 20. FW-13, FW PRESS TK ISLN                         | 63. FW-64 ISLN-WC                  |
| 21. FW-15, CO PRESS GAGE-FW SYS                     | 64. FW-57, SUPPLY TO WC            |
| 22. FW-80, PRESSURE TANK DRAIN                      | 65. FW-53, COLD FW TO SINK         |
| 23. FW-14, COLD FW HOSE CONN                        | 66. FW-56, SUPPLY TO WC            |
| 24. FW-9, FW PUMP NO. 1 SUCT FR FW TANKS            | 67. FW-54, HOT FW TO SINK          |
| 25. FW-11, FW PUMP NO. 1 DISCH                      | 68. FW-55 SUPPLY TO WC             |
| 26. FW-10, FW PUMP NO. 2 SUCT FR FW TKS             | 69. FW-51 COLD FW TO SINK          |
| 27. FW-17, HOT FW HOSE CONN                         | 70. FW-52 HOT FW TO SINK           |
| 28. FW-18, SEA CHEST - HOT FW CONN                  | 71. FW-48 SUPPLY TO URINAL         |
| 29. FW-16, COLD FW HOSE CONN                        | 72. FW-49 COLD FW TO SINK          |
| 30. FW-28, HOT FW WASHDOWN                          | 73. FW-50 HOT FW TO SINK           |
| 31. FW-36, HOT FW TO AFT GALY SINK                  | 74. FW-47 SUPPLY TO URINAL         |
| 32. FW-35, COLD FW TO AFT GALY SINK                 | 75. FW-43 COLD FW TO WASHER        |
| 33. FW-32, HOT FW TO FWD GALY SINK                  | 76. FW-44 HOT FW TO WASHER         |
| 34. FW-31, COLD FW TO FWD GALY SINK                 | 77. FW-76 SUPPLY TO SH             |
| 35. FW-30, COLD FW TO DF (MESS DK)                  | 78. FW-75, SUPPLY TO SH            |
| 36. FW-40, GAYLORD PUMP DISCH                       | 79. FW-74, SUPPLY TO SH            |
| 37. FW-34, COLD FW TO GAYLORD HOOD PUMP             | 80. FW-41, COLD FW TO LAU SINK     |
| 38. FW-1, FILL CONN-FW TKS                          | 81. FW-42, HOT FW TO LAU SINK      |
| 39. FW-33, COLD FW TO BVGE & COFFEE MAKER (MESS DK) | 82. FW-66, ISLN-HOT FW             |
| 40. FW-38, HOT FW TO SICKBAY SINK                   | 83. FW-67, ISLN-COLD FW            |
| 41. FW-37, COLD FW TO SICKBAY SINK                  | 84. FW-46, SUPPLY TO URINAL        |
| 42. FW-39, SUPPLY TO WC                             | 85. FW-65, COLD FW TO DF           |
| 43. FW-77, SUPPLY TO SH                             |                                    |

FIGURE 2-112. Fresh Water Piping System (Sheet 8 of 8).

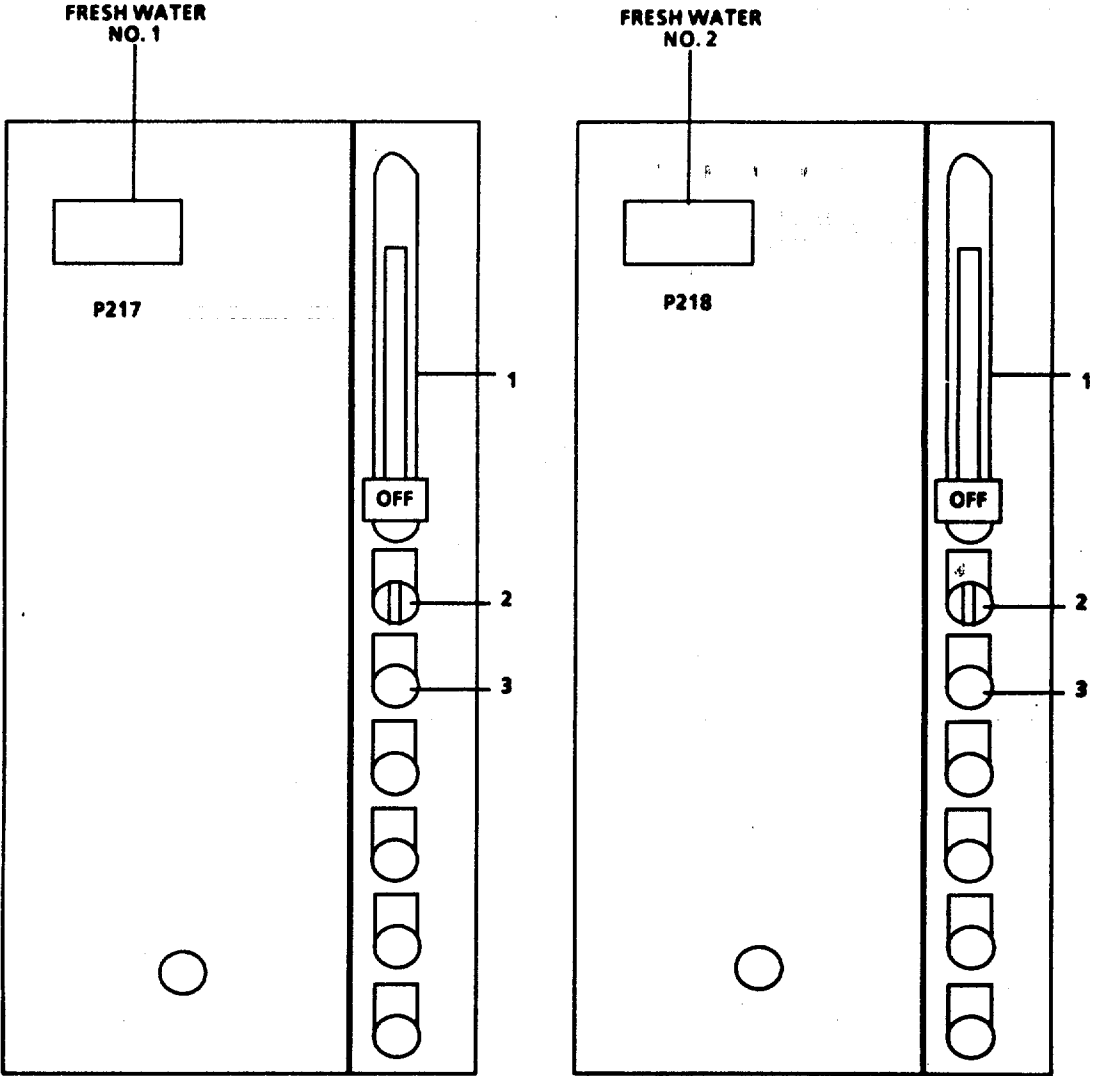

- LEGEND**
- 1. CIRCUIT BREAKER HANDLE
  - 2. HAND-OFF-AUTO
  - 3. START

FIGURE 2-113. Fresh Water Motor Controllers.

- (e) Open FWM-3, SW SUPPLY TO FW MAKER NO. 1 (16).
  - (f) Set tank level indicator switch to ON position.
  - (g) Open FWM-4, BRINE OVBD DISCH (1).
  - (h) Open FW-4 and FW-5 FW DSCH (17 and 18).
  - (i) Open FW-2 and FW-3 FILL ISLN (5 and 6).
- (2) On Reverse Osmosis Unit Control Panel (FIGURE 2-114), set HI PRESSURE BYPASS switch (1) to OPEN position.
- (3) Set CLEANING/BRINE DISCHARGE VALVE (8) to OPERATE position (arrow down).
- (4) At Auxiliary Machinery Motor Control Center (FIGURE 2-115) perform the following:
- (a) Set FW MAKER NO. 1 circuit breaker (2) to ON position.
  - (b) Set FW MAKER NO. 2 circuit breaker (1) to ON position.
- (5) On Reverse Osmosis Unit Control Panel (FIGURE 2-114), set ON-OFF POWER switch (7) to ON position.
- (6) Set S1 POWER switch (4) to ON position.
- (7) Set REMOTE operating switch to ON position.

**NOTE**

LOW PRESSURE GAGE (3) needle goes negative temporarily as high pressure pump applies suction in the feedwater line. Needle goes positive as the feedwater reaches low pressure boost pump. If the low pressure gage will not indicate position pressure, turn power switch S1 off, and make sure feed line to RO unit is open.

- (8) Slowly turn HI PRESSURE BYPASS switch (1) clockwise to Ro position.

**NOTE**

HI PRESSURE GAGE (2) needle indicates pressure rise. QUALITY LOW indicator (6) will go out, QUALITY HIGH indicator (5) lights in approximately 2 minutes. Assuming that high quality lamp is lit, check flow meter for normal production level. Refer to troubleshooting section of TM 55-1905-223-24-7, page 2-14, if there is any discrepancy in the instrument indications.

e. Marine Sanitation Device.

**CAUTION**

Never use Marine Sanitation Device Supply and Discharge Piping System for disposal of garbage.

(1) Align Marine Sanitation Device Supply and Discharge Piping System (FIGURE 2-116) as follows:

(a) Open SW-9, SUPPLY TO MSD (1).





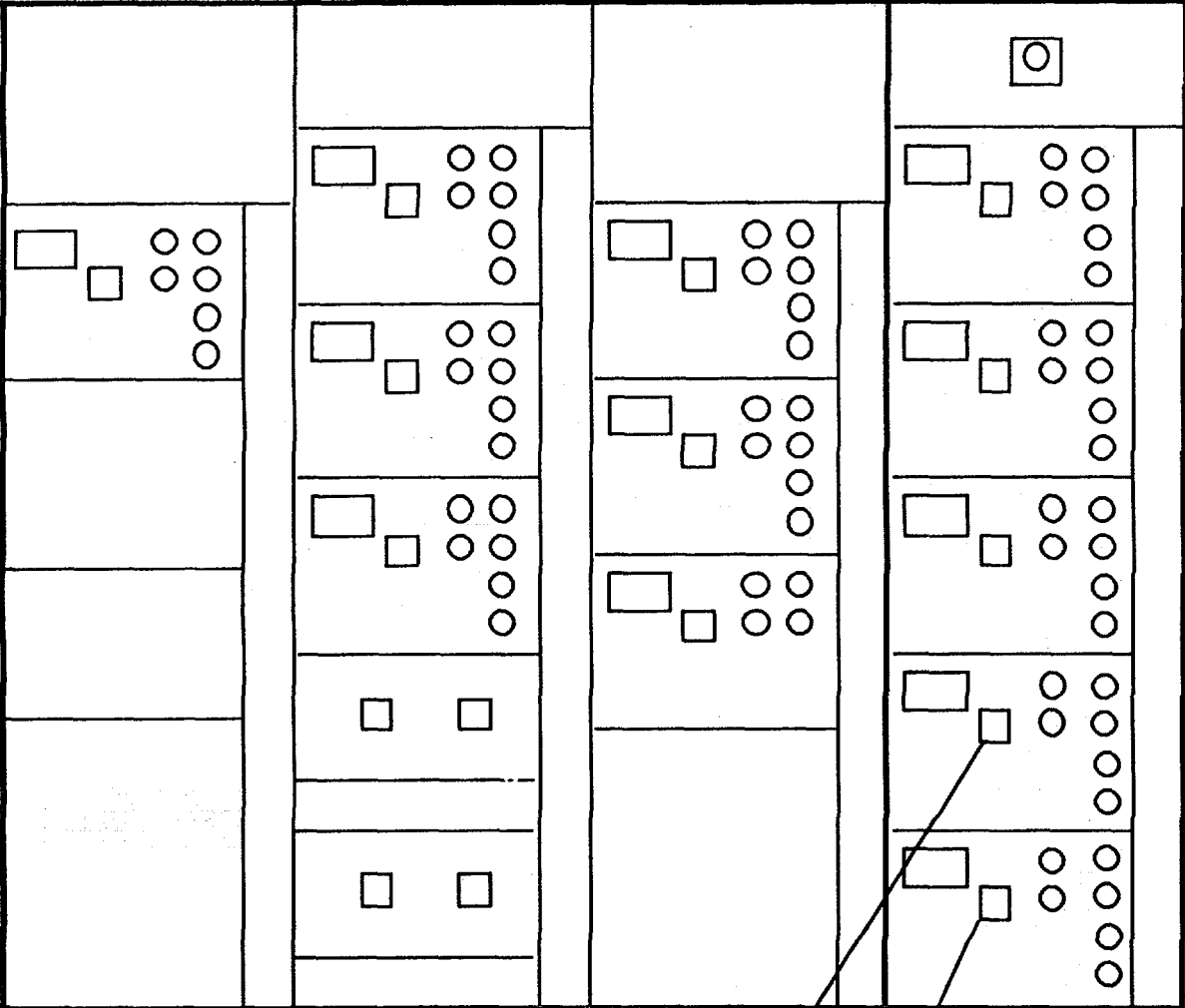

- LEGEND**
- 1. FRESH WATER MAKER NO. 1
  - 2. FRESH WATER MAKER NO. 2

FIGURE 2-115. Auxiliary Machinery Motor Control Center.

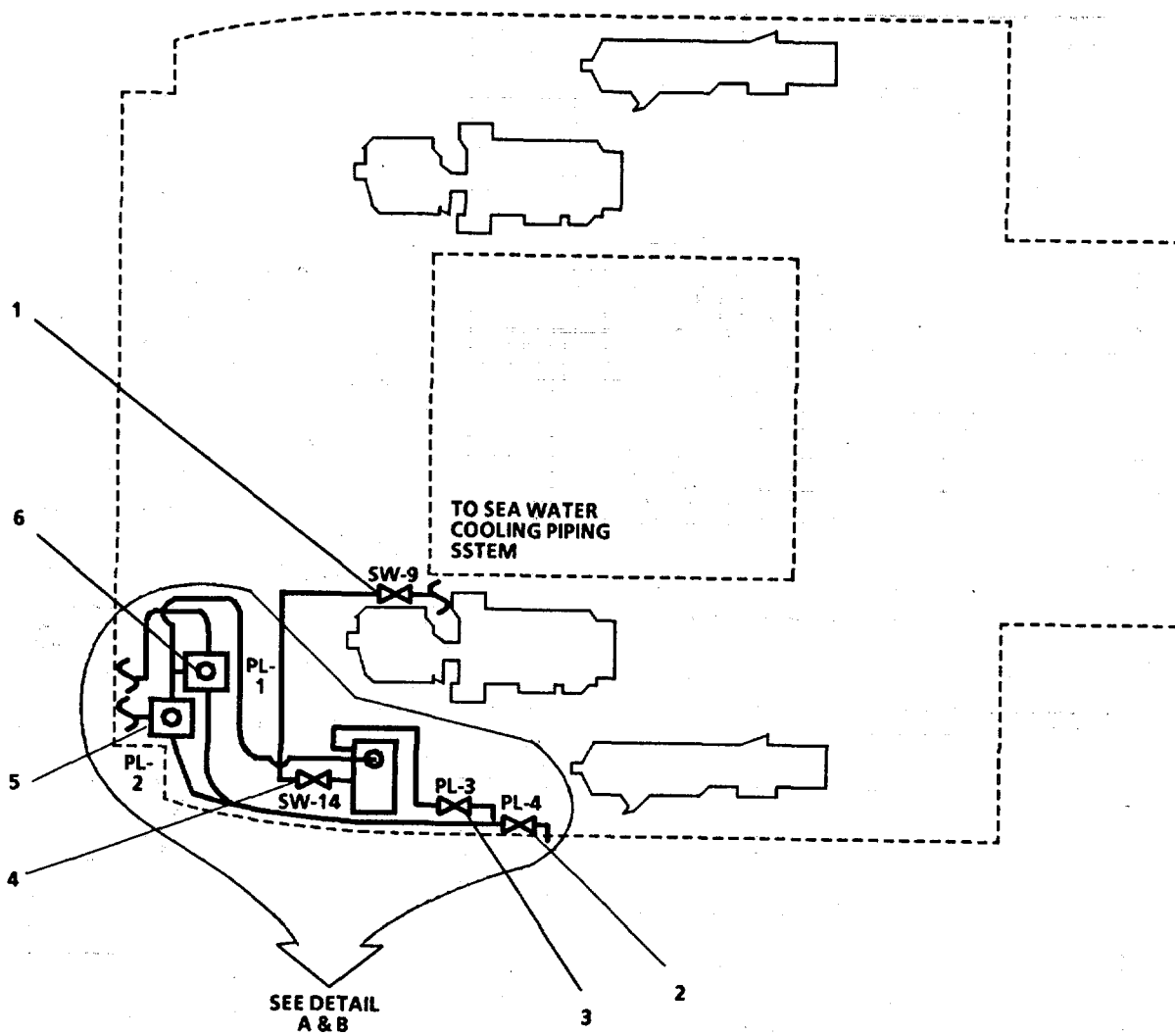

**LEGEND**

- 1. SW-9, SUPPLY TO MSD
- 2. PL-4, OVBD DISCH
- 3. PL-3, MSD OVBD DISCH
- 4. SW-14, ISOLATION-MSD
- 5. PL-2, GRAYWATER DIVERTER TO MSD OR OVBD
- 6. PL-1, BLACKWATER DIVERTER TO MSD OR OVBD

FIGURE 2-116. Marine Sanitation Device Supply and Discharge Piping System (Sheet 1 of 2).

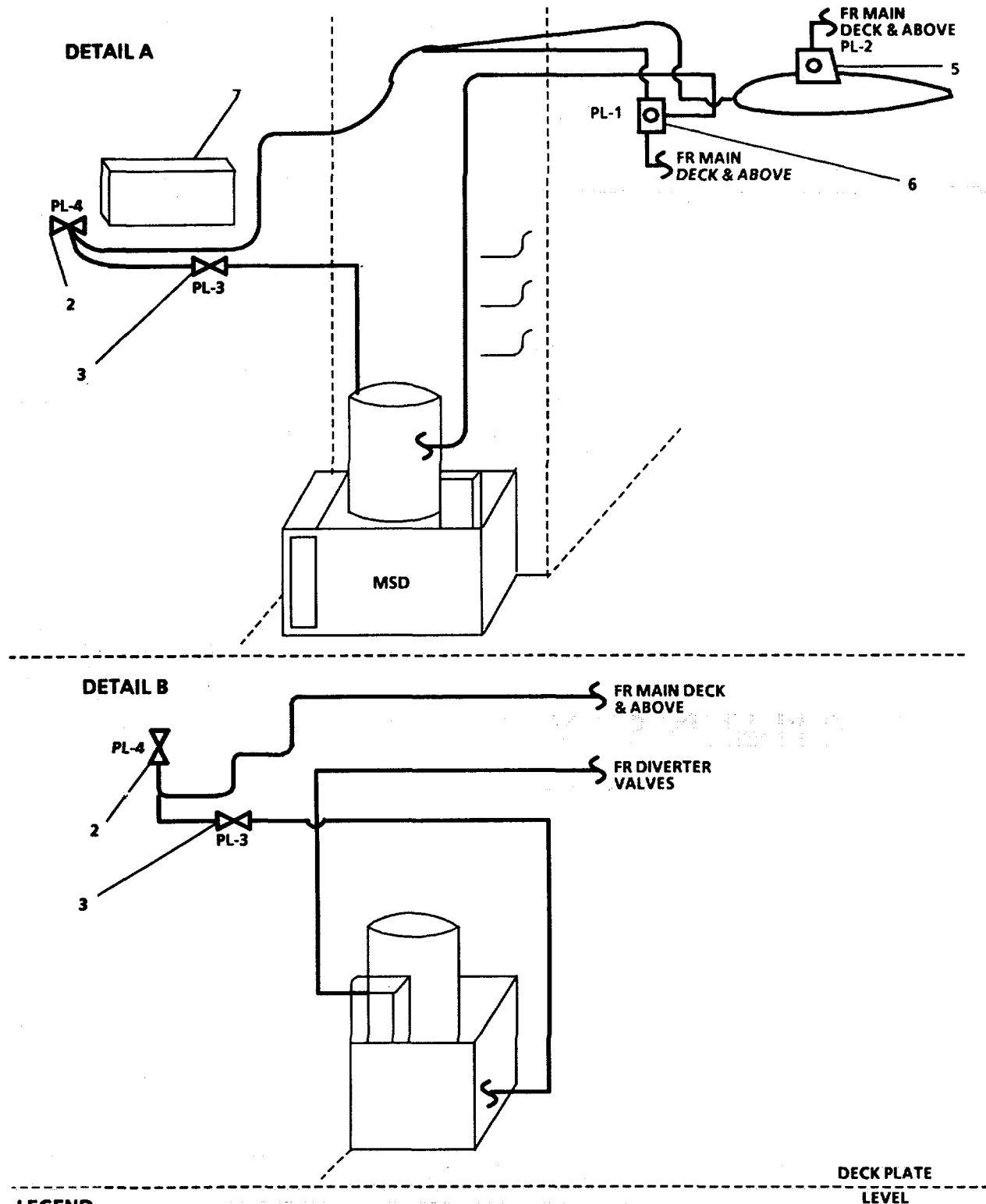

**LEGEND**

- 2. PL-4, OVBD DISCH
- 3. PL-3, MSD OVBD DISCH
- 5. PL-2, GRAYWATER DIVERTER TO MSD OR OVBD
- 6. PL-1, BLACKWATER DIVERTER TO MSD OR OVBD
- 7. CLORINE BLEACH TANK

FIGURE 2-116. Marine Sanitation Device Supply and Discharge Piping System (Sheet 2 of 2).

- (b) Open SW-14, ISOLATION-MSD (4).
  - (c) Fill Chlorine Bleach Holding Tank (7).
  - (d) Open SEWAGE INLET VALVE (8).
  - (e) Ensure PL-1, BLACKWATER DIVERTER TO MSD or OVBD (6) and PL-2, GRAYWATER DIVERTER TO MSD or OVBD (5) are aligned to flow to MSD.
  - (f) Open PL-4, OVBD DISCH (2) and PL-3, MSD-OVBD DISCH (3).
- (2) At Marine Sanitation Device (FIGURE 2-117).
- (a) Set DEMAND switch (2) to DEMAND position.
  - (b) Set BACKWASH switch (3) to WITHOUT BACKWASH position.
  - (c) Set NORMAL-RESET/DISABLE switch (1) to NORMAL position.

**NOTE**

If NORMAL-RESET/DISABLE switch (1) is in RESET/DISABLE position, the unit will start to operate.

- (d) On power panel P204 set circuit breaker 2 to ON position.

**CAUTION**

Red COMMODE WARNING LIGHT (4) must be off before flushing.

**NOTE**

COMMODE WARNING LIGHT is located in starboard companionway 01 deck.

**2-10. Gyrocompass System.**

- a. Gyro Compass MARK 27 MOD 1.

**NOTE**

Gyro Compass startup procedure should begin at least 2 hours before the compass is to be used to allow proper settling. The compass should also have been stopped for a minimum of 1/2 hour before restarting.

- (1) In Pilothouse, Power Panel EP103, set MK2T GYRO PWR CONV UNIT circuit breaker 1 to ON position.
- (2) On MK 37 MOD E Transmission Unit, set POWER switch (1, FIGURE 2-118) to UP position.
- (3) On Gyro Compass MARK 27 MOD 1 Electronic Control Panel (FIGURE 2-119), set RPTR switch (7) to OFF position.

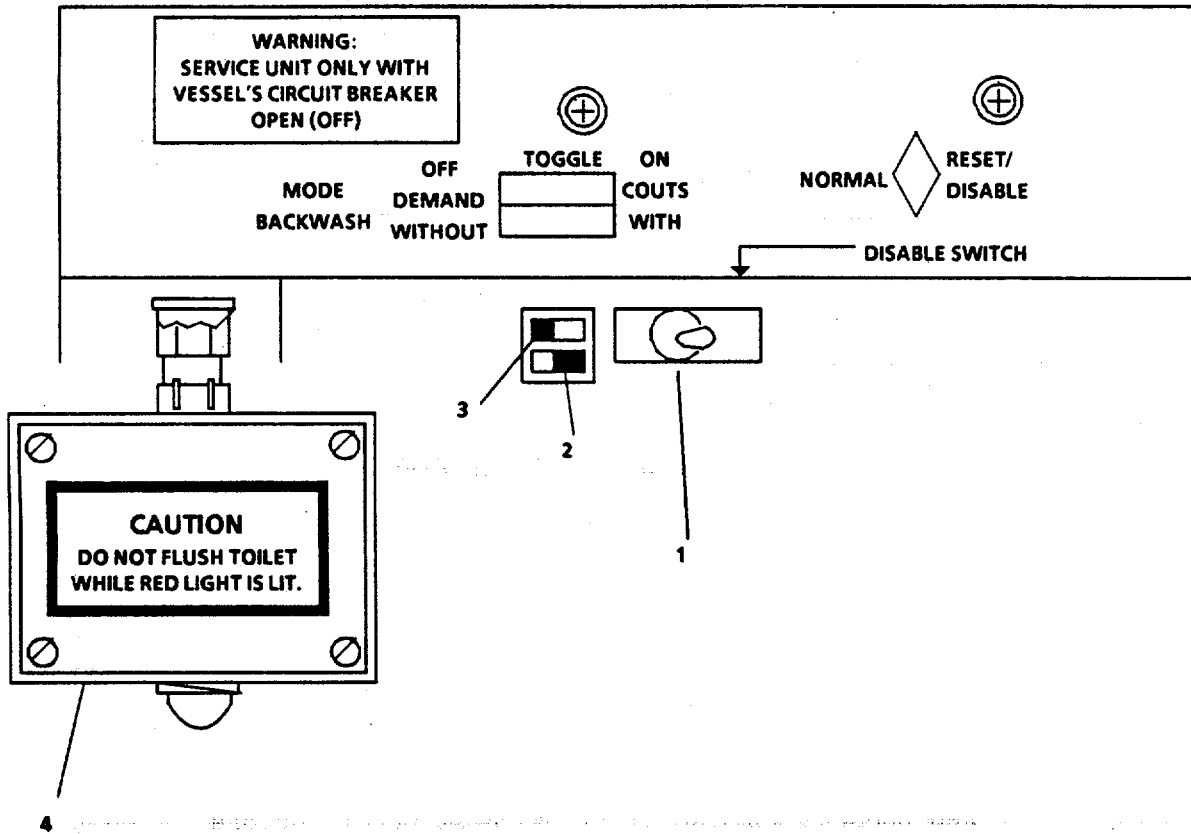

**LEGEND**

- 1. NORMAL-RESET/DISABLE
- 2. DEMAND SWITCH
- 3. BACKWASH SWITCH
- 4. COMMODE WARNING LIGHT

FIGURE 2-117. Marine Sanitation Device.

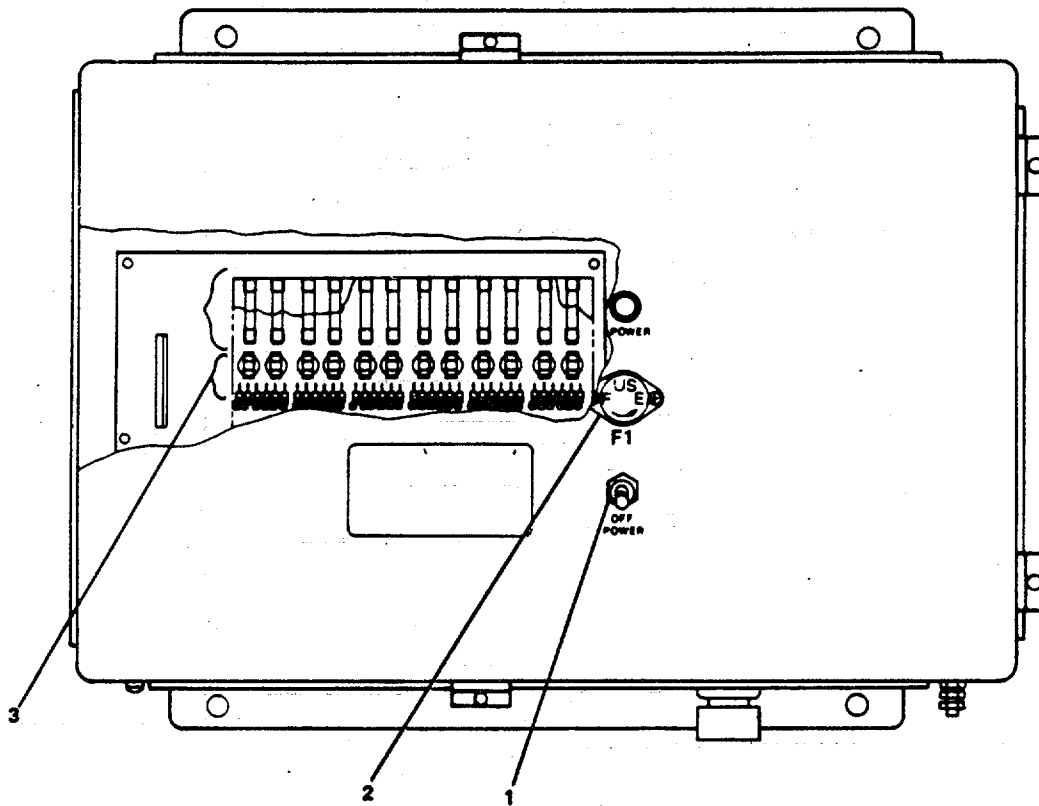

**LEGEND**

- 1. POWER
- 2. FUSE F1
- 3. REPEATER SWITCHES A2551 THROUGH A2512

FIGURE 2-118. MK 37 Mod E Transmission Unit.

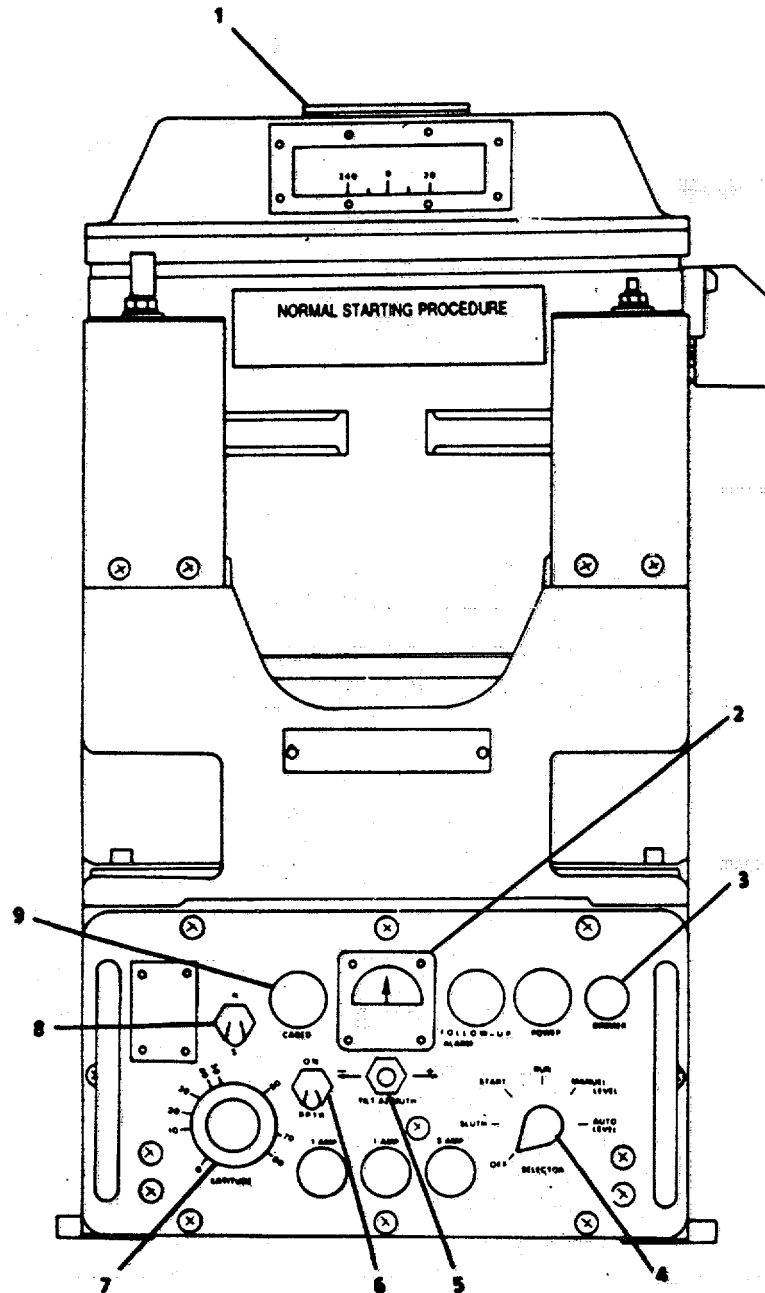

**LEGEND**

- |                 |             |
|-----------------|-------------|
| 1. CAGED BUTTON | 6. RPT      |
| 2. LEVEL METER  | 7. LATITUDE |
| 3. DIMMER       | 8. N-S      |
| 4. SELECTOR     | 9. CAGED    |
| 5. TILT/AZIMUTH |             |



FIGURE 2-119. Gyro Compass MK 27 Mod 1 Electronic Control Panel.



**NOTE**

**Compass will slew rapidly if the gyro is encaged.**

- (4) Set SELECTOR switch (4) to SLEW position.

**NOTE**

Compass will slew rapidly if the gyro is uncaged.

- (5) Observe if CAGED indicator (9) is lit. If not lit, press CAGED BUTTON (1) on top of binnacle to cage gyro, and wait 5 minutes for ballistic fluid to stabilize.

**NOTE**

In the (+) position, the card rotates counterclockwise; in the (-) position, the card rotates clockwise.

- (6) To slew heading, use TILT/AZIMUTH switch (5) to rotate the compass card to approximate ship heading.
- (7) Set SELECTOR switch (4) to START position. Wait 10 minutes before proceeding.
- (8) Press CAGED BUTTON (1) on top of binnacle. CAGED indicator (9) will go OFF.
- (9) Set SELECTOR switch (4) to MANUAL LEVEL position.
- (10) Use TILT/AZIMUTH switch (5) to level gyro. Gyro is level when LEVEL METER (2) indicates zero.
- (11) Set SELECTOR switch (4) to RUN position.
- (12) Set N-S switch (8) as required.
- (13) Set LATITUDE control (6) to ship latitude.

**CAUTION**

Do not operate synchronizer knob when repeater switch is energized.

- (14) On standard Bearing Repeaters (FIGURE 2-120), press and hold SYNCHRONIZER KNOB (2) to engage gear train.
- (15) Rotate REPEATER CARD (1) to Gyro Compass heading.
- (16) Release SYNCHRONIZER KNOB (2).

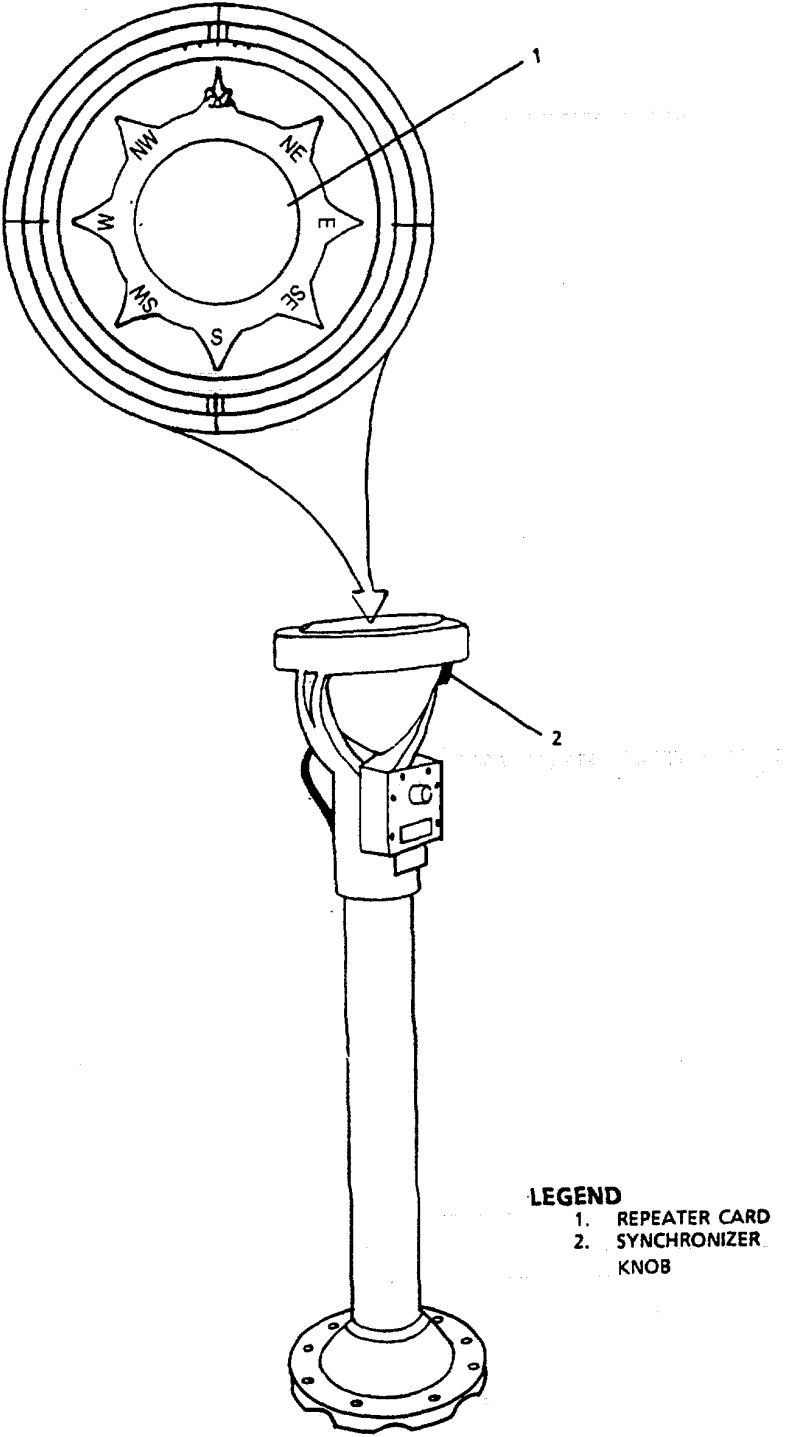

FIGURE 2-120. Standard Bearing Repeater.

**CAUTION**

Do not operate SYNCHRONIZER KNOB (2) when repeater motor is energized.

**NOTE**

Repeat for all repeaters.

- (17) On Open Scale Compass Repeater (FIGURE 2-121), press and hold SYNCHRONIZER KNOB (1) to engage gear train.
- (18) Rotate REPEATER CARD (2) to gyro compass heading.
- (19) Release SYNCHRONIZER KNOB (1).
- (20) On Gyro Compass MARK 27 MOD 1 Electronic Control Panel (FIGURE 2-119), set RPTR switch (7) to ON position.
- (21) Adjust DIMMER control (3) as required.

b. Mark 37 Mod E Transmission Unit

**WARNING**

High voltage is present at fuse FI (2, FIGURE 2-118) and Power switch S1 terminals on the inside of the cabinet cover, even when the unit is turned OFF. THESE VOLTAGES ARE DANGEROUS. Use extreme care when servicing or operating the unit with the front cover open. Personal injury could result.

- (1) On Mk 37 Mod E Transmission Unit (FIGURE 2-118), set POWER switch (1) to OFF position. Open front cover and set REPEATER SWITCHES A2S1 through A2S12 (3) to OFF position. Close front cover.
- (2) Turn on gyro and allow time for gyro compass to settle.
- (3) Set POWER Switch (1) to UP position.

**NOTE**

Compass repeaters are located above the Pilothouse Console, Starboard wing of Pilothouse, Port wing of Pilothouse, Flying Bridge of Pilothouse, and Steering Compartment.

- (4) Set each compass repeater individually to gyro compass heading.
- (5) Set each associated REPEATER SWITCH (3) to ON position when synchronized.

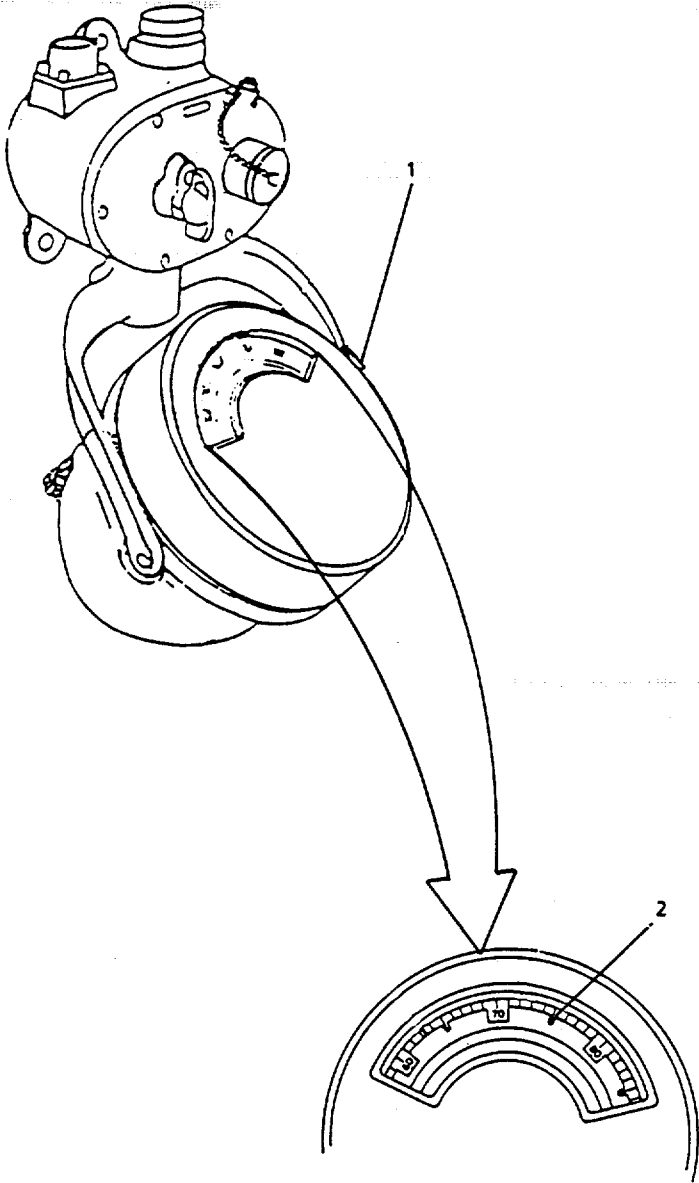

- LEGEND**  
1. SYNCHRONIZER KNOB  
2. REPEATER CARD

FIGURE 2-121. Open Scale Compass Repeater.

c. Synchronize compass repeaters after ship service power failure**NOTE**

The master compass and electronic control of the MK 27 Mod 1 gyro compass operate directly from an external 24 Vdc power source. A ship service power failure will not effect the gyro compass, but compass repeaters must be reset.

- (1) On gyro compass MK 27 MOD 1 Electronic Control Panel (FIGURE 2-119), set R,PTR switch (7) to OFF position.

**CAUTION**

Do not operate synchronizer knob when repeater switch is energized.

- (2) On Open Scale Compass Repeater (FIGURE 2-121), press and hold SYNCHRONIZER KNOB (1) to engage gear train.
- (3) Rotate REPEATER CARD (2) to gyro compass heading.
- (4) Release SYNCHRONIZER KNOB (1).
- (5) On Standard Bearing Repeater (FIGURE 2-120), press and hold SYNCHRONIZER KNOB (2) to engage gear train.
- (6) Rotate REPEATER CARD (1) to gyro compass heading.
- (7) Release SYNCHRONIZER KNOB (2).
- (8) On Gyro Compass Mk 27 Mod 1 Electronic Control Panel (FIGURE 2-119), set RPTR switch (7) to ON position.

d. Autopilot Mode**NOTE**

Autopilot mode allows hands-off steering of vessel.

**Change 2 2-365/(2-366 blank)**

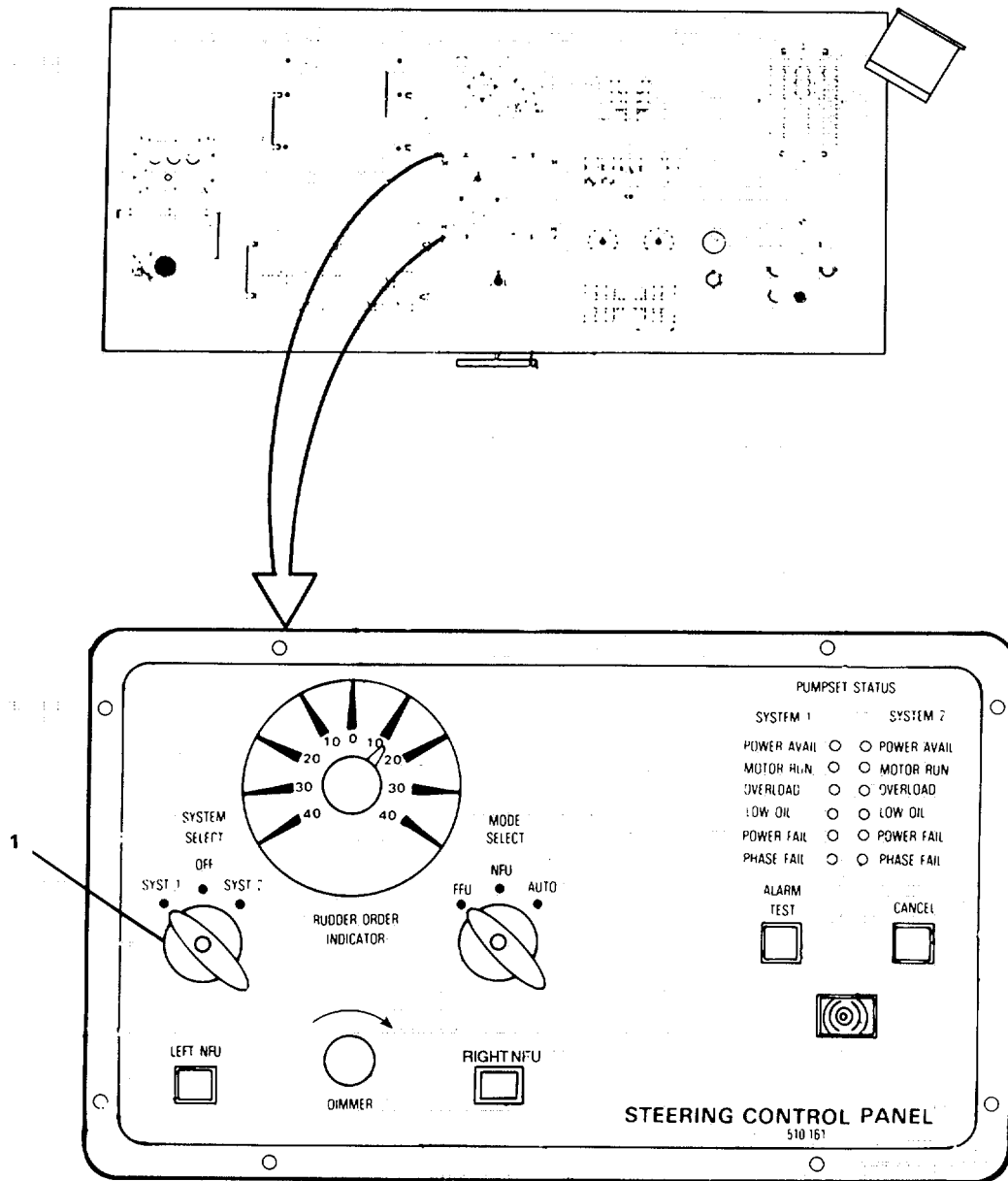

**LEGEND**  
**1. SYSTEM SELECT**

FIGURE 2-122. Steering Control Panel

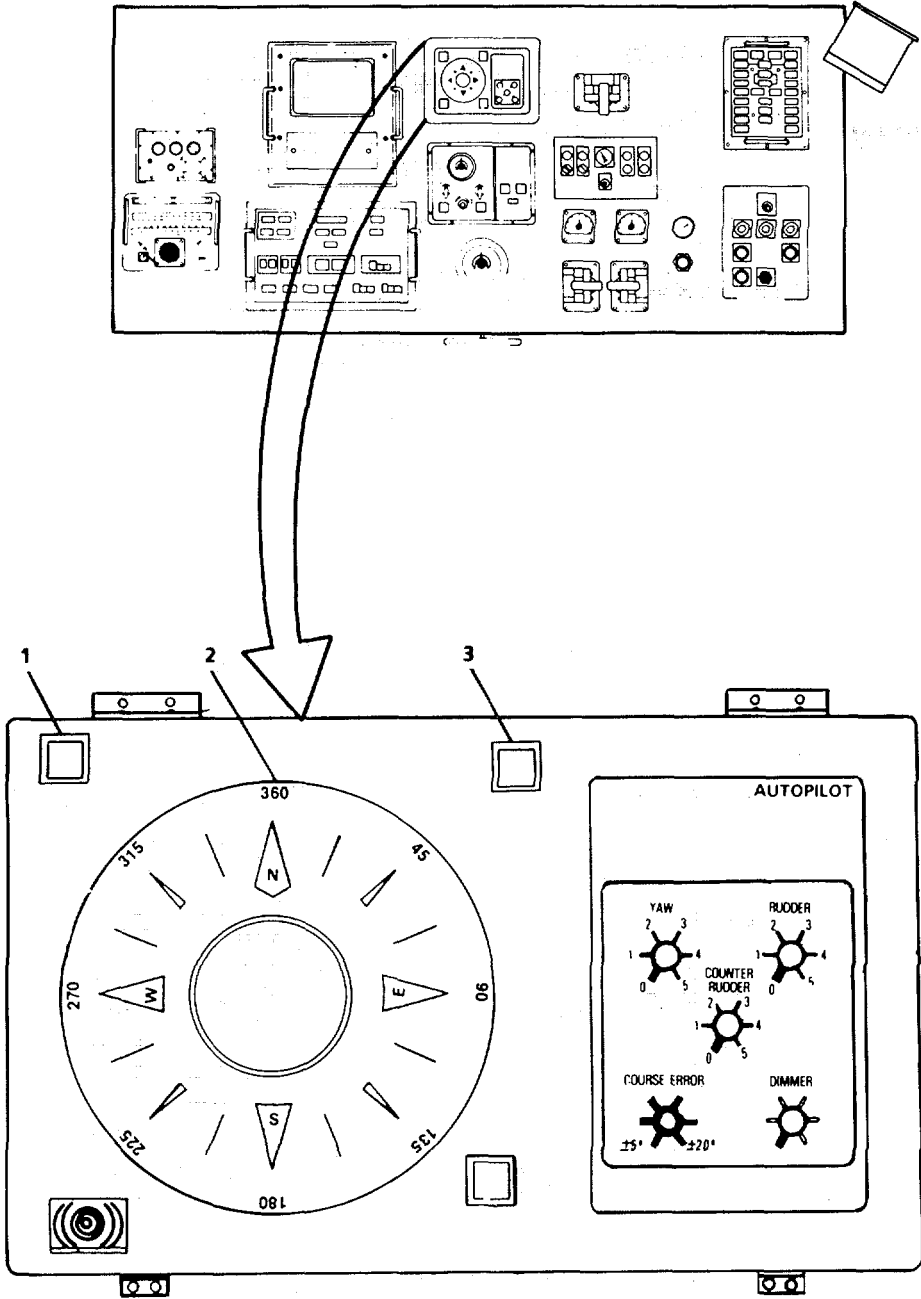

- LEGEND**
- 1. (RED)
  - 2. COMBINATION REPEATER
  - 3. GREEN

FIGURE 2-123. Autopilot Control Panel.

## 2-10 d.1 Autopilot Mode

**NOTE**

Autopilot mode allows hands-off steering of vessel.

**WARNING**

- Autopilot is not intended to take the place of the helmsman, but rather assist in steering vessel.
  - It is the responsibility of the captain (and required by law) to ensure and maintain safe navigation and control of vessel at all times in accordance with the Rules of the Sea.
  - Autopilot is intended for operation in open waters, clear of all obstructions, and other vessels.
  - It may be necessary -to regain manual steering control quickly and to deactivate Autopilot if the vessel alters or fails to maintain set course or if set course may jeopardize vessel.
- (1) On the Steering Control Panel (Pilothouse Console), set MODE SELECT switch (1, FIGURE 2-123.1) to AUTO position.
  - (2) Auto mode locks onto ship heading.
  - (3) To change course in AUTO mode, on Autopilot Control Panel (FIGURE 2-123.2) turn the heading changer (1) to the left or right.
  - (4) Autopilot will bring LCU to new selected heading as indicated on the indicator dial (2).



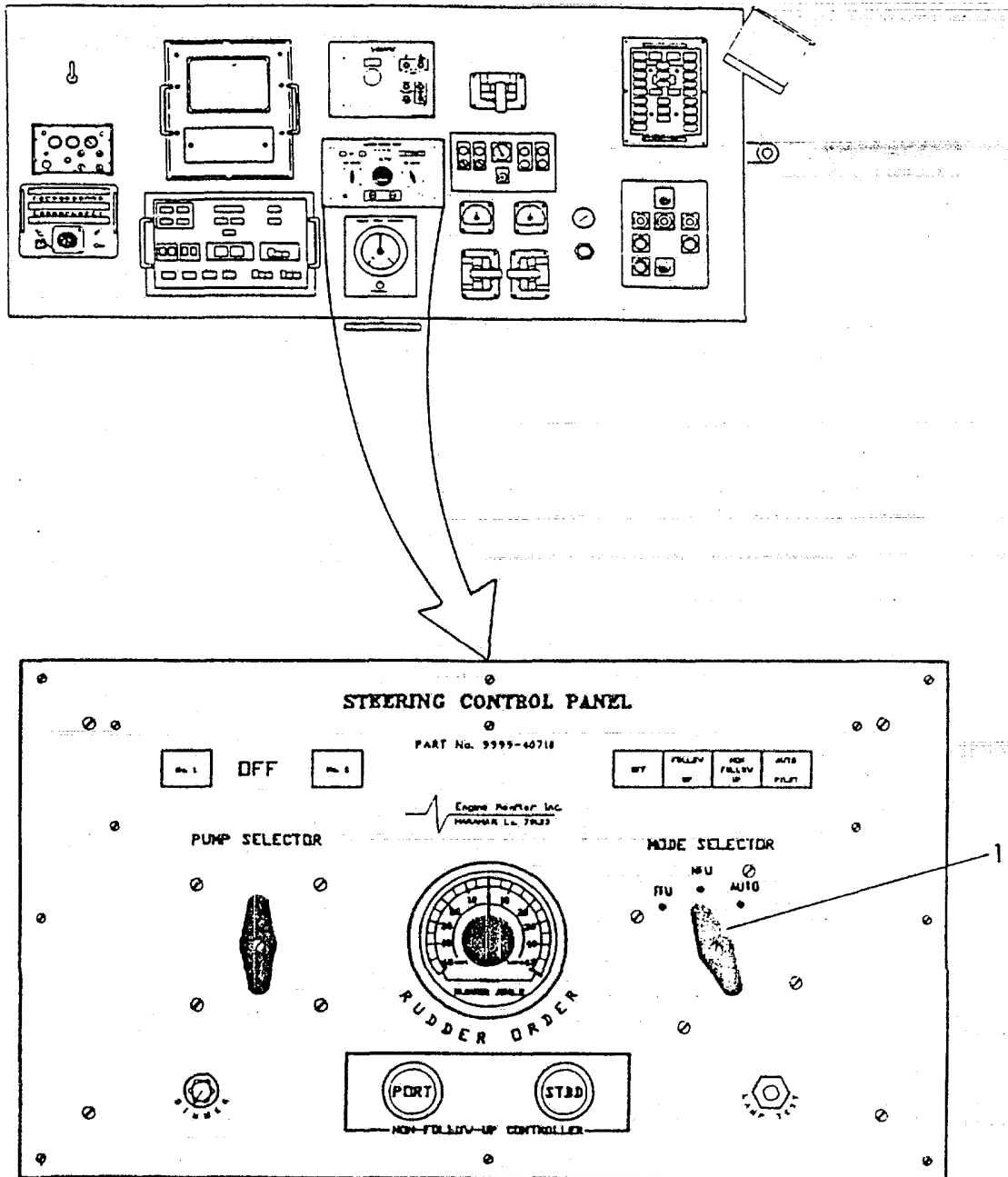

FIGURE 2-123.1. Steering Control Panel

Change 2 2-368.2

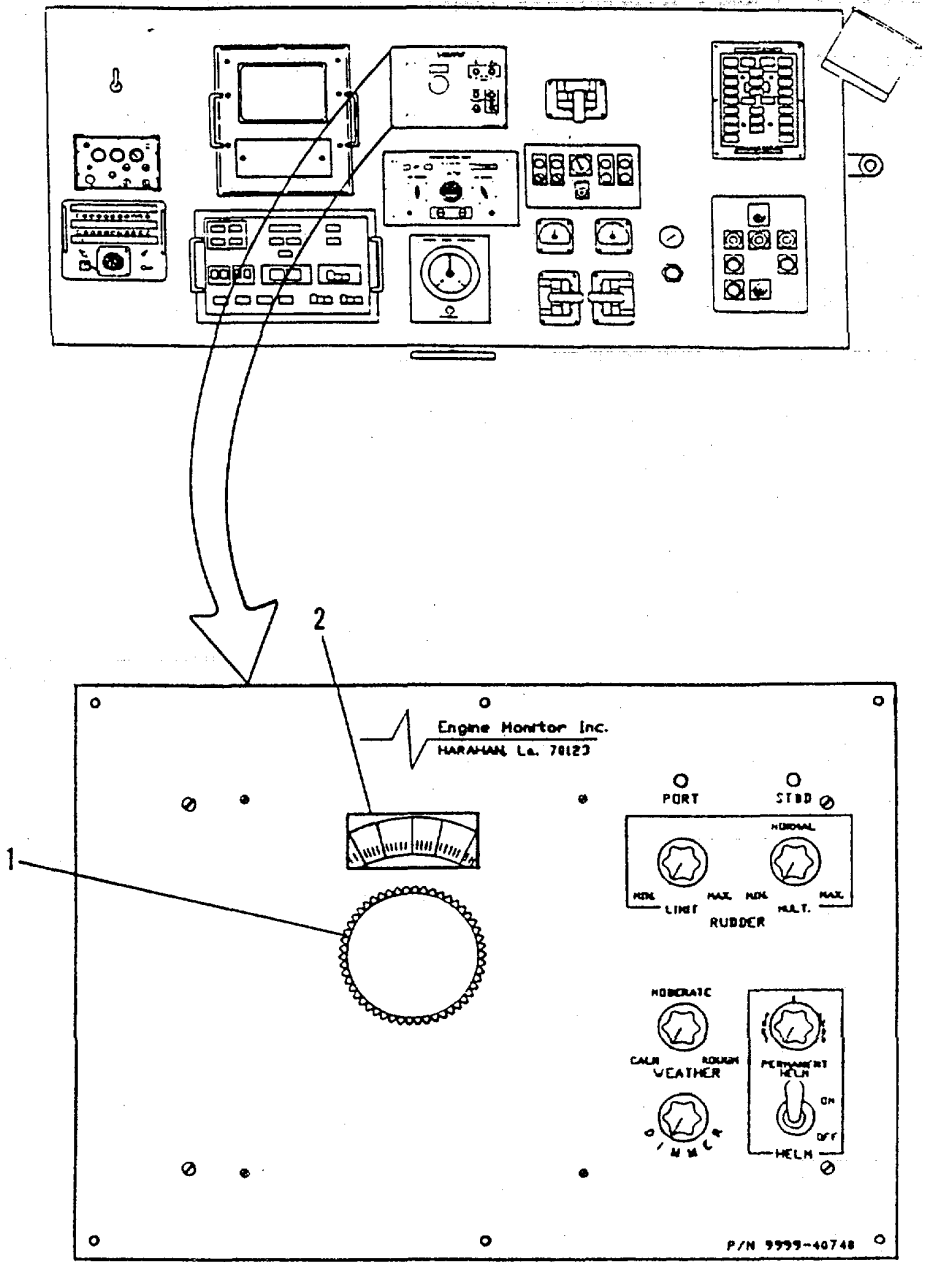

Figure 2-123.2. Autopilot Control Panel

**2-11. Air Start Main Generator**

- a. Align Fuel Oil Filter, Transfer, and Supply Piping System (FIGURE 2-124) to generator (air start) as follows:
  - (1) Open FO-36, DAY TK F-12P SUPPLY TO PORT MN ENG & SSDG (22).
  - (2) Open FO-32, SUPPLY TO PORT SSDG (27).
  - (3) Open FO-40, RETURN FR PORT SSDG TO DAY TK F-12P (26).
- b. Align SSDC Fresh Water Cooling Piping System (FIGURE 2-125).
  - (1) Open FWC-14, EXP TK-SSDG PORT (8).
  - (2) Position FWC-12, KEEL CLR/SSDG PORT CLG MODE SELECTOR (11) to port position.
  - (3) Open FWC-10, KEEL CLR INLET (10).
  - (4) Open FWC-8, KEEL CLR OUTLET (1).
- c. Align SSDG Compressed Air Piping System (FIGURE 2-126).
  - (1) Open LPA-12, SUPPLY TO SSDG PORT (27).

**Change 2 2-368.4**

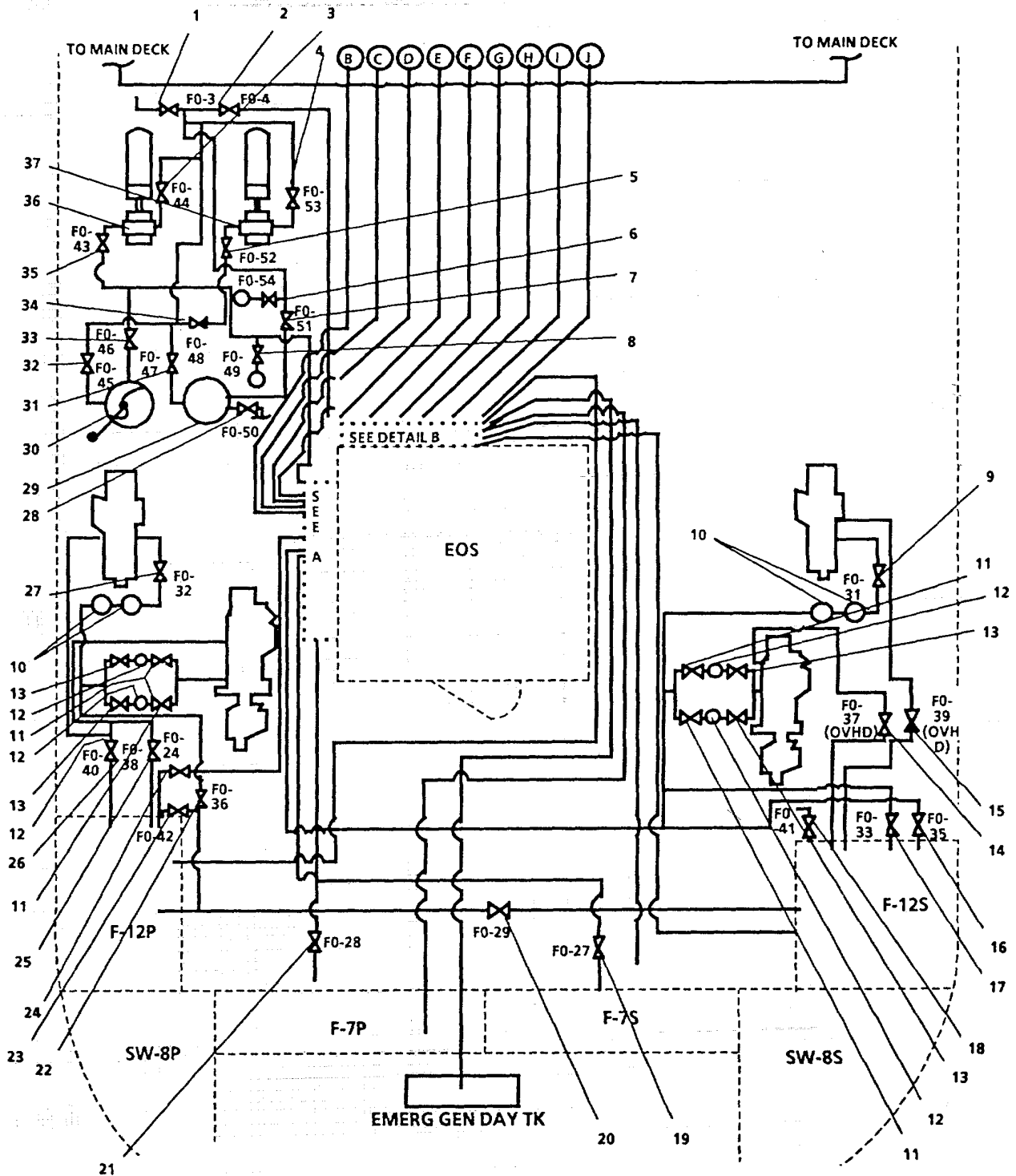

FIGURE 2-124. Fuel Oil Filter, Transfer, and Supply Piping System (Sheet 1 of 6).

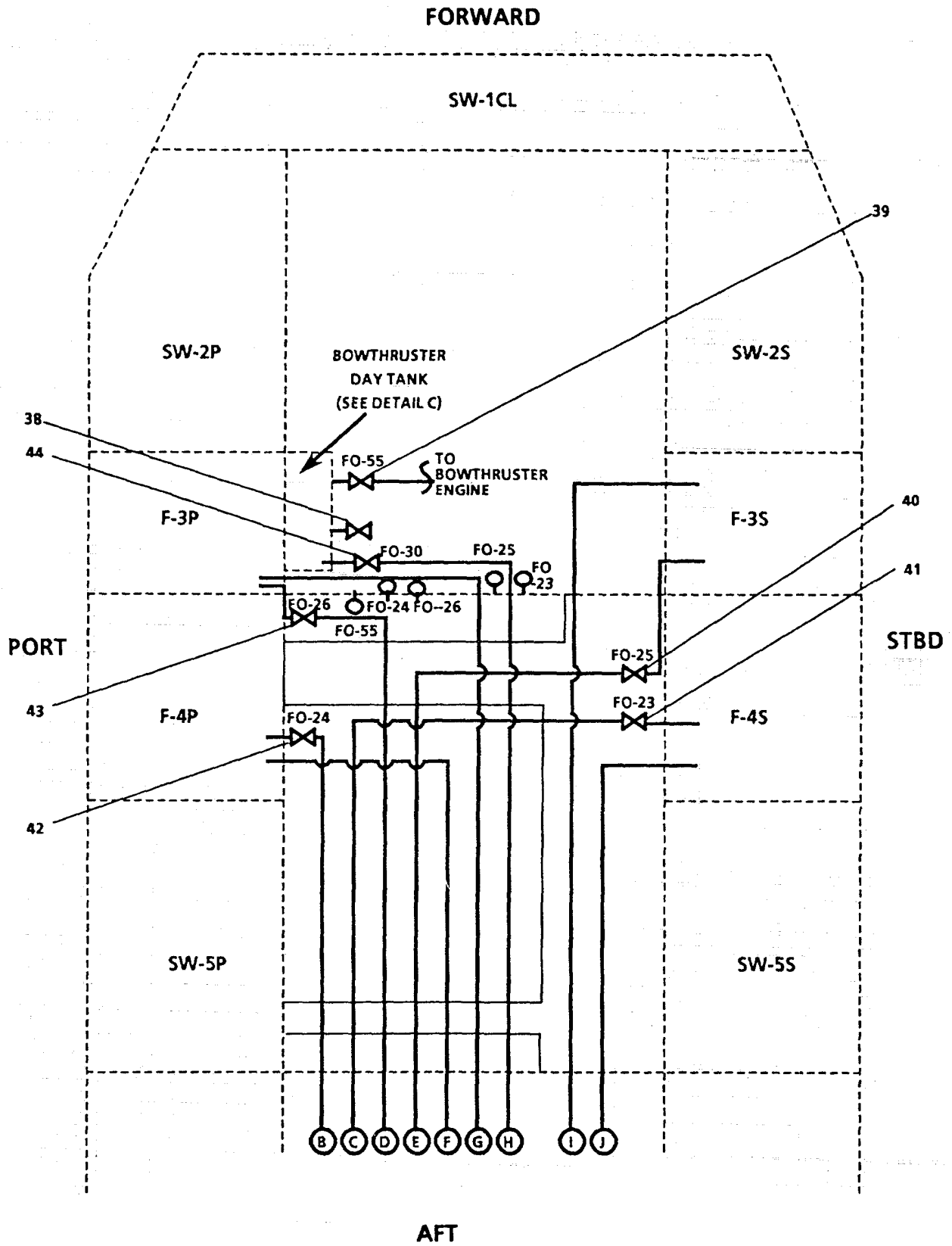

FIGURE 2-124. Fuel Oil Filter, Transfer, and Supply Piping System (Sheet 2 of 6).

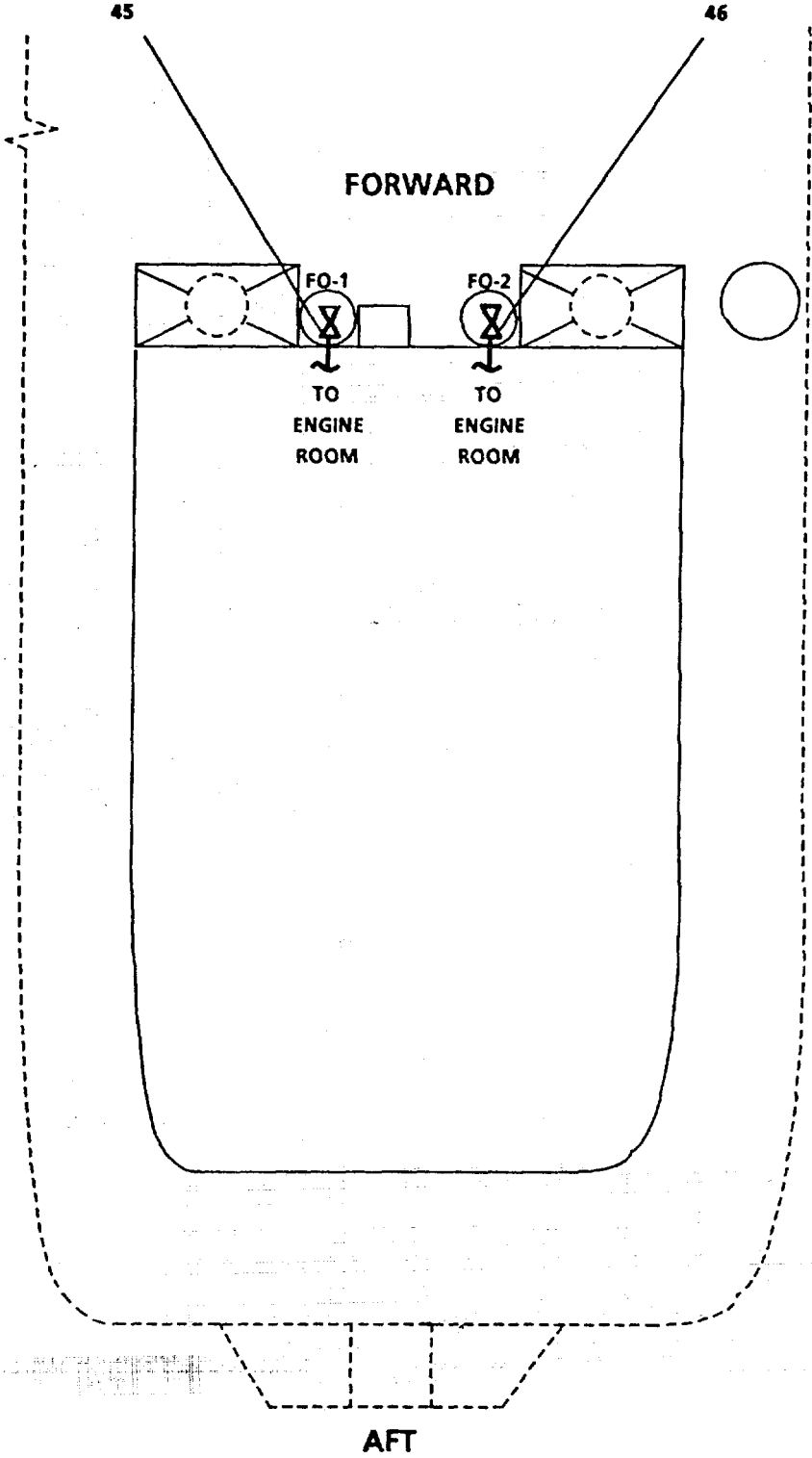

FIGURE 2-124. Fuel Oil Filter, Transfer, and Supply Piping System (Sheet 3 of 6).

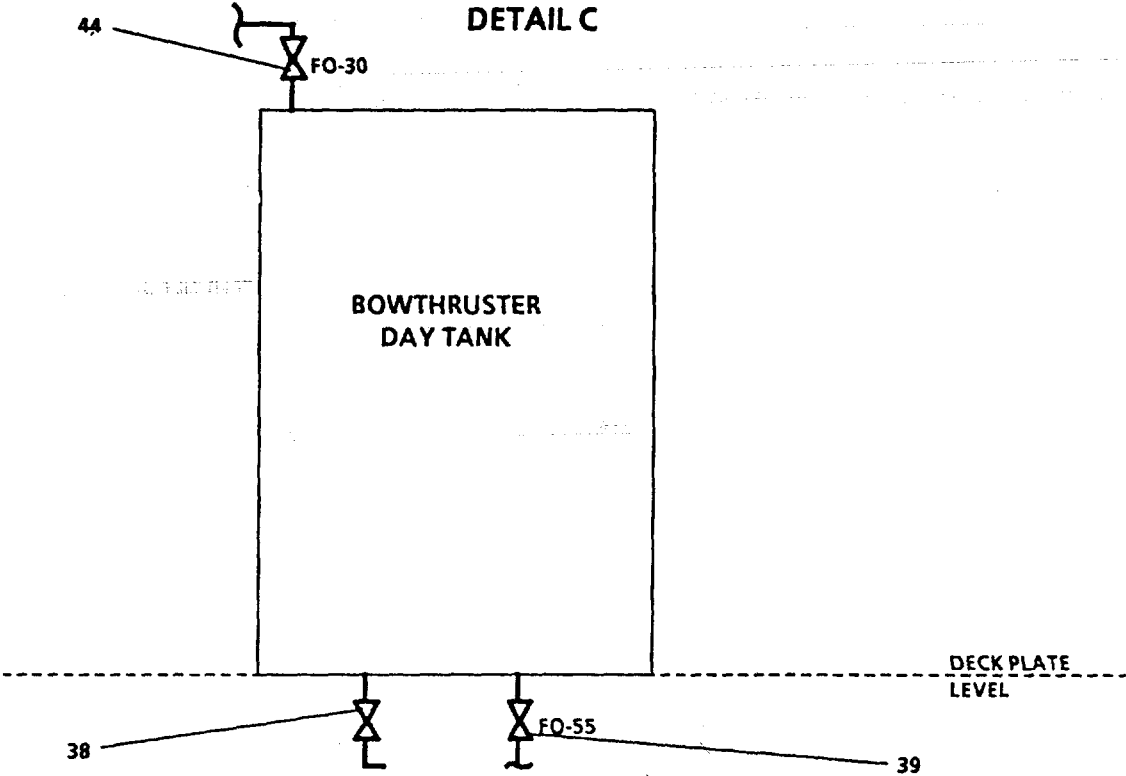

FIGURE 2-124. Fuel Oil Filter, Transfer, and Supply Piping System (Sheet 5 of 6).

**LEGEND**

- |  |  |
|--|--|
| 1. FO-3, ISLN-FILL/DISCH STATIONS                    | 33. FO-46, HAND PUMP SUCT                  |
| 2. FO-4, SUPPY TO FO SUPPLY MANF                     | 34. FO-48, BY-PASS FILTER/SEPARATOR        |
| 3. FO-44, DISCH -NO. 2 XFR PUMP                      | 35. FO-43, SUCT-NO. 2 XFR PUMP             |
| 4. FO-53, DISCH- NO. 1 XFR PUMP                      | 36. NO. 2 XFR PUMP                         |
| 5. FO-52, SUCT-NO. 1 XFR PUMP                        | 37. NO. 1 XFR PUMP                         |
| 6. FO-54, PUMP DISCH PRESS GAGE                      | 38. BOW THRUSTER DAY TK DRAIN              |
| 7. FO-51, FILTER/SEPARATOR OUTLET                    | 39. FO-55, SUPPLY TO BOW THRUSTER ENGINE   |
| 8. FO-49, PUMP SUCT PRESS GAGE                       | 40. FO-25, SUCT FR TK F-3S                 |
| 9. FO-31, SUPPLY TO STBD SSDG                        | 41. FO-23, SUCT FR TK F-4S                 |
| 10. SSDG FUEL FILTERS                                | 42. FO-24, SUCT FR TK F-4P                 |
| 11. MN ENG FILTER DISCH VALVE                        | 43. FO-26, SUCT FR TK F-3P                 |
| 12. MN ENG FILTER                                    | 44. FO-30, SUPPLY TO BOW THRUSTER DAY TK   |
| 13. MN ENG FILTER INLET VALVE                        | 45. FO-1, FUEL OIL FILL/DISCH              |
| 14. FO-37, RETURN FR STBD MN ENG TO DAY TK F-12S     | 46. FO-2, FUEL OIL FILL/DISCH              |
| 15. FO-39, RETURN FR STBD SSDG TO DAY TK F-12S       | 47. FO-20, SUCT FR TK F-4S                 |
| 16. FO-35, SUCT FR DAY TK F-12S                      | 48. FO-18, SUCT FR TK F-12P                |
| 17. FO-33, DAY TK F-12S SUPPLY TO STBD MN ENG & SSDG | 49. FO-16, SUCT FR TK F-7S                 |
| 18. FO-41, DRAIN FR DAY TK F-12S                     | 50. FO-15, SUCT FR TK F-7P                 |
| 19. FO-27, SUCT FR TK F-7S                           | 51. FO-17, SUCT FR TK F-12S                |
| 20. FO-29, CROSS CONN - DAY TKS                      | 52. FO-19, SUCT FR TK F-4P                 |
| 21. FO-28, SUCT FR TK F-7P                           | 53. FO-21, SUCT FR TK F-3P                 |
| 22. FO-36, DAY TK F-12P SUPPLY TO PORT MN ENG & SSDG | 54. FO-22, SUCT FR TK F-3S                 |
| 23. FO-42, DRAIN FR DAY TK F-12P                     | 55. FO-12, SUPPLY TO TK F-7P               |
| 24. FO-34, SUCT FR DAY TK F-12P                      | 56. FO-10, SUPPLY TO DAY TK F-12P          |
| 25. FO-38, RETURN FR PORT MN ENG TO DAY TK F-12P     | 57. FO-8, SUPPLY TO TK F-3S                |
| 26. FO-40, RETURN FR PORT SSDG TO DAY TK F-12P       | 58. FO-6, SUPPLY TO TK F-3P                |
| 27. FO-32, SUPPLY TO PORT SSDG                       | 59. FO-5, SUPPLY TO TK F-4P                |
| 28. FO-50, DRAIN TO SLUDGE TK                        | 60. FO-7, SUPPLY TO TO BOW THRUSTER DAY TK |
| 29. FUEL FILTER/COALESCER                            | 61. FO-9, SUPPLY TO TK F-4S                |
| 30. FUEL TRANSFER HAND PUMP                          | 62. FO-11, SUPPY TO EMER GEN DAY TK        |
| 31. FO-47, FILTER/SEPARATOR INLET                    | 63. FO-13, SUPPY TO TK F-7S                |
| 32. FO-45, HAND PUMP DISCH                           | 64. FO-14, SUPPY TO TK F-12S               |

FIGURE 2-124. Fuel Oil Filter, Transfer, and Supply Piping System (Sheet 6 of 6).



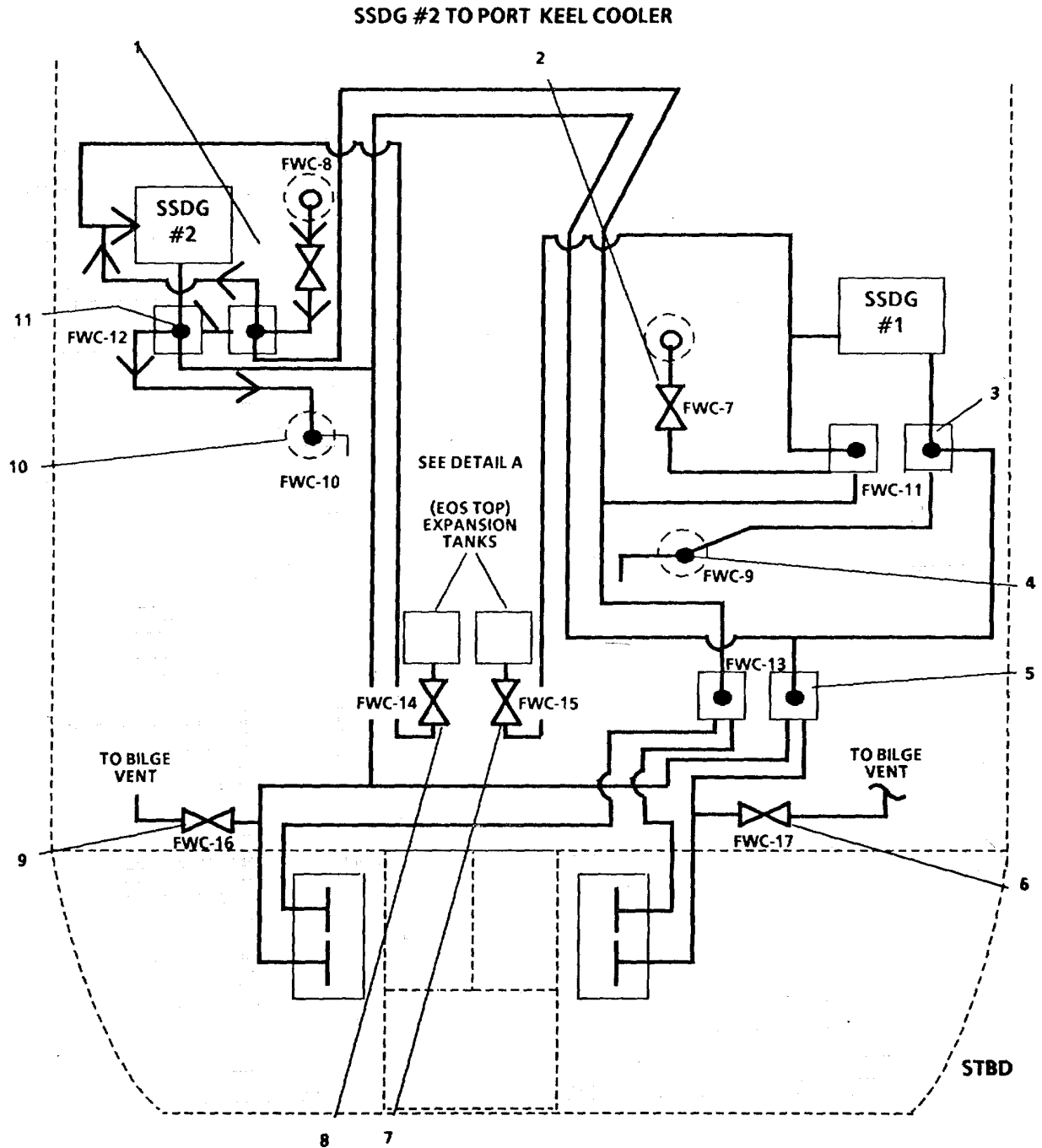

**LEGEND**

- |   |  |
|---|--|
| 1. FWC-8, KEEL CLR OUTLET                           | 7. FWC-15, EXP TK-SSDG STBD                      |
| 2. FWC-7, KEEL CLR OUTLET                           | 8. FWC-14, EXP TK-SSDG PORT                      |
| 3. FWS-11, KEEL CLR/SSDG-STBD CLG MODE              | 9. FWC-16, VENT KEEL CLR IN SWP-8P               |
| 4. FWC-9, KEEL CLR INLET                            | 10. FWC-10, KEEL CLR INLET                       |
| 5. FWC-13, KEEL CLR SELECTOR BLST TK SW-8P OR SW-8S | 11. FWC-12, KEEL CLR/SSDG-PORT CLG MODE SELECTOR |
| 6. FWC-17, VENT KEEL CLR IN SW-8S                   |  |

FIGURE 2-125. SSDG Fresh Water Cooling Piping System (Sheet 1 of 2).

DETAIL A

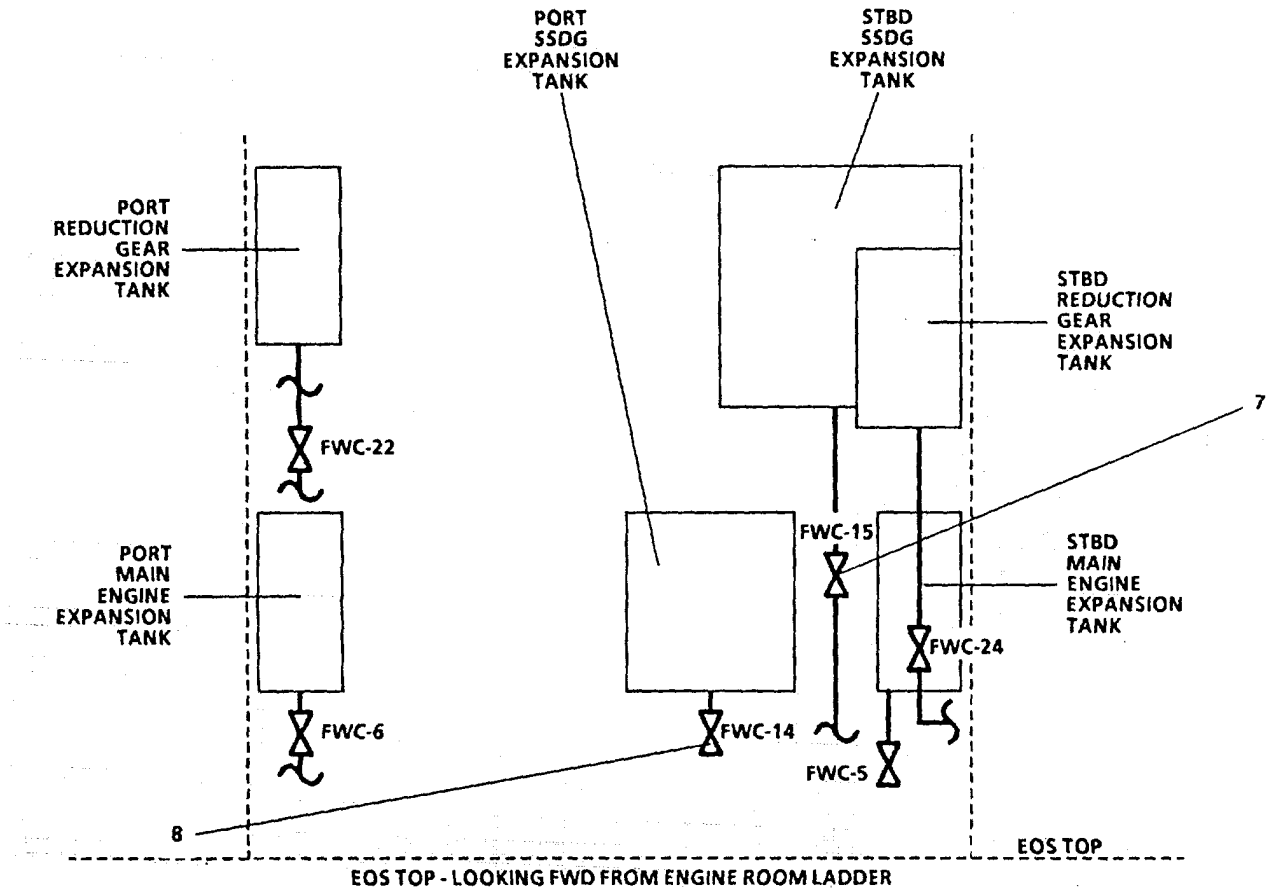

LEGEND:

- 7. FWC-15, EXP TK-SSDG STBD
- 9. FWC-14, EXP TK-SSDG PORT

FIGURE 2-125. SSDG Fresh Water Cooling Piping System (Sheet 2 of 2).

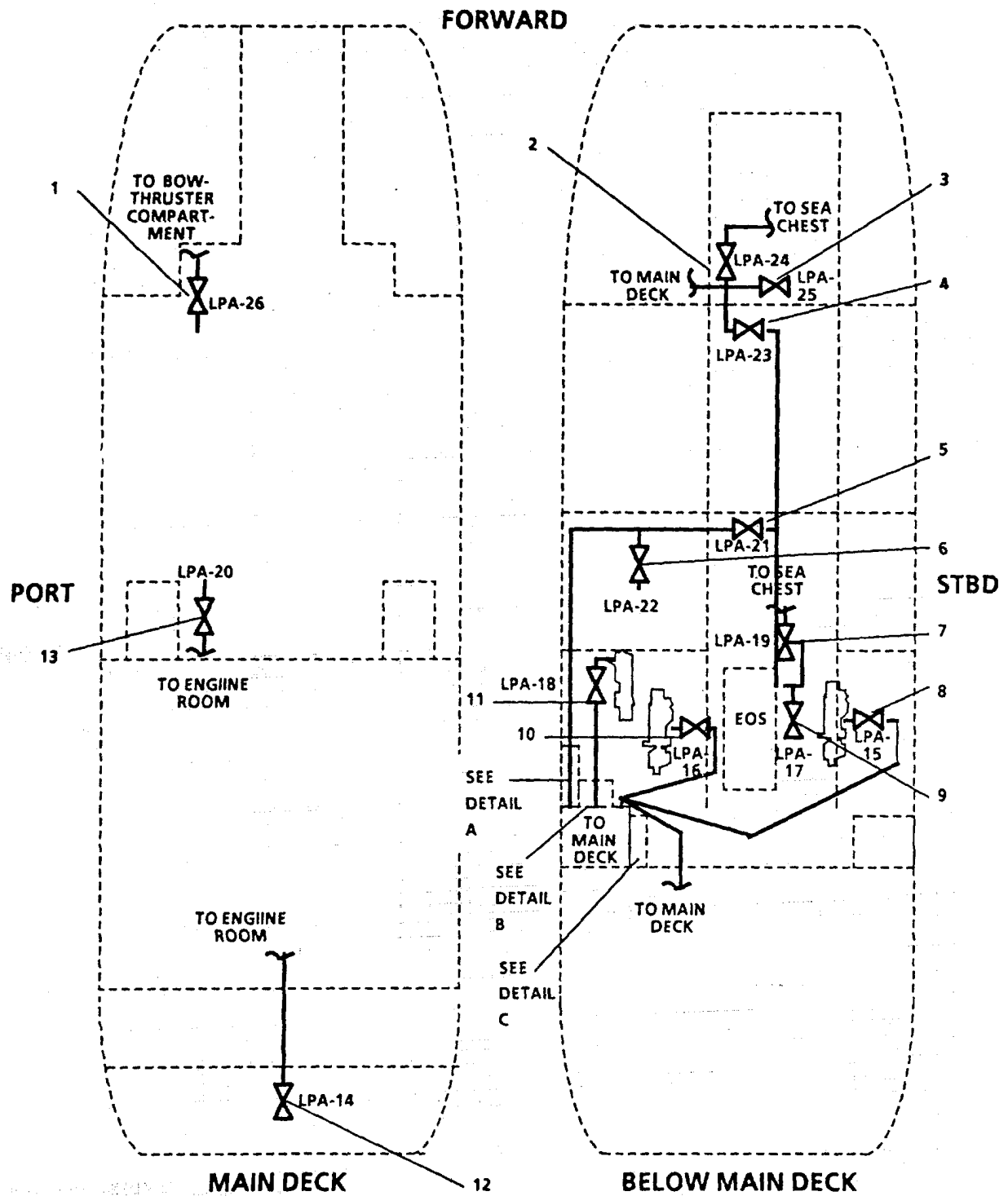

FIGURE 2-126. Compressed Air Piping System (Sheet 1 of 5).

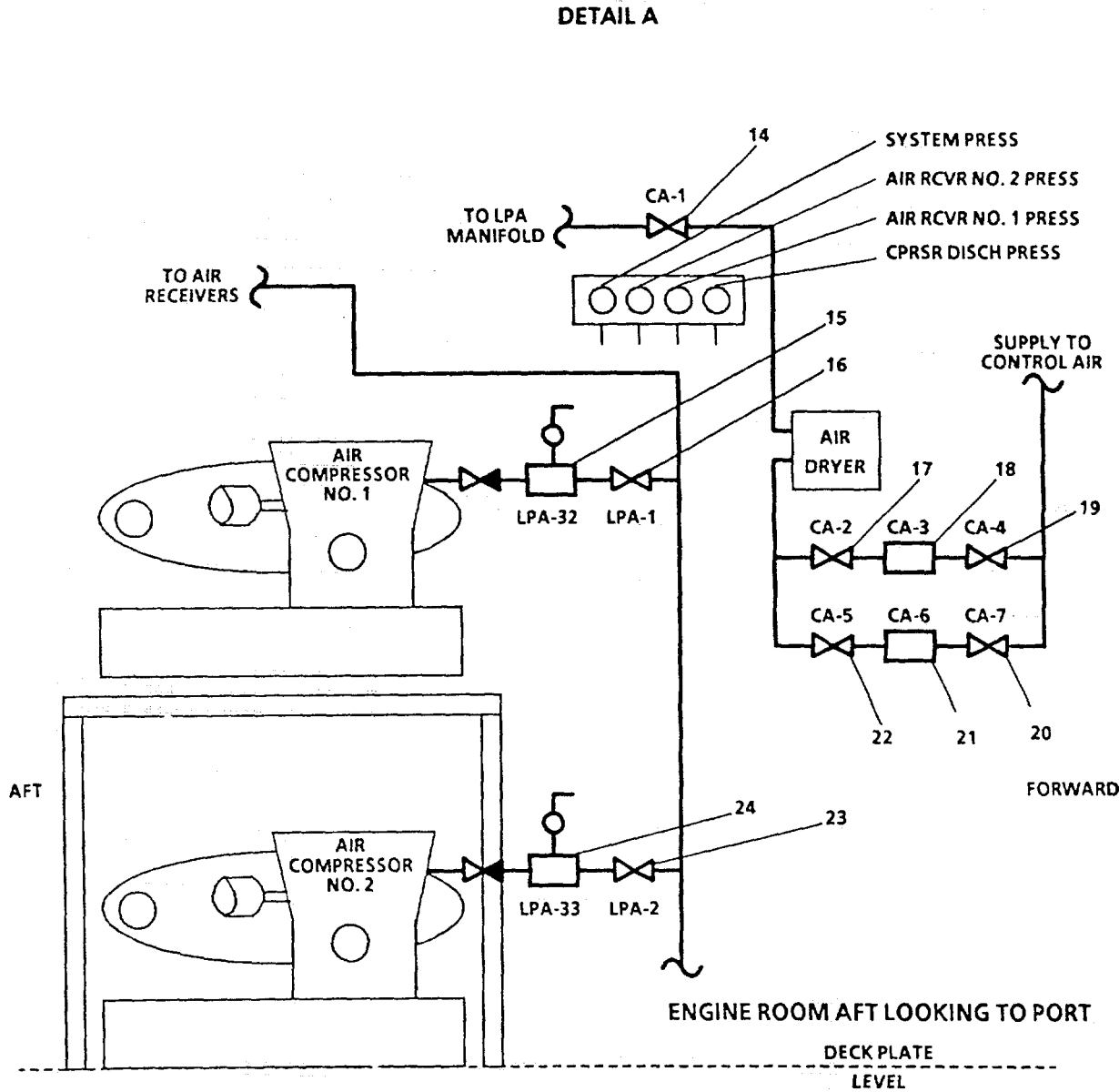

FIGURE 2-126. Compressed Air Piping System (Sheet 2 of 5).

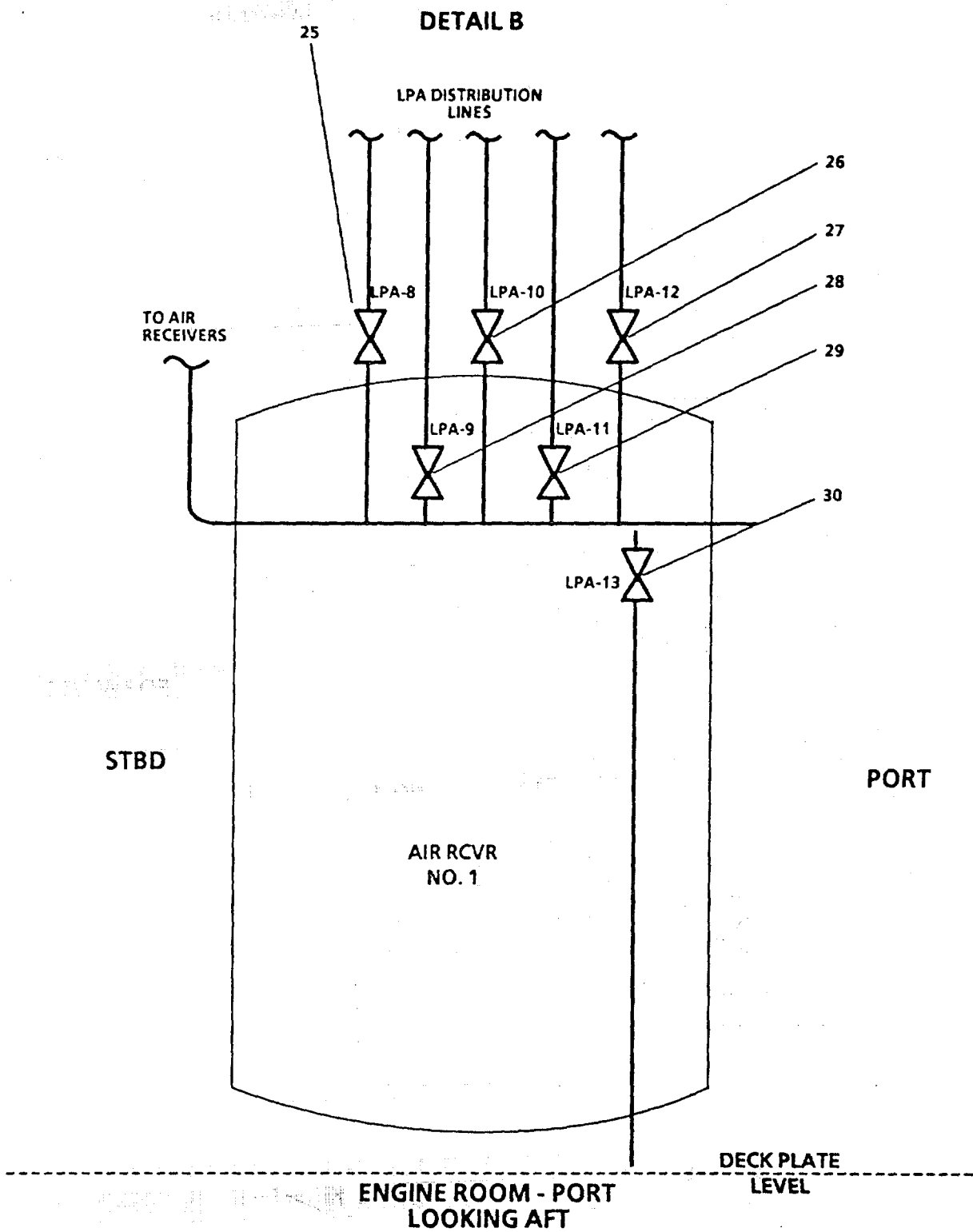

FIGURE 2-126. Compressed Air Piping System (Sheet 3 of 5).

DETAIL C

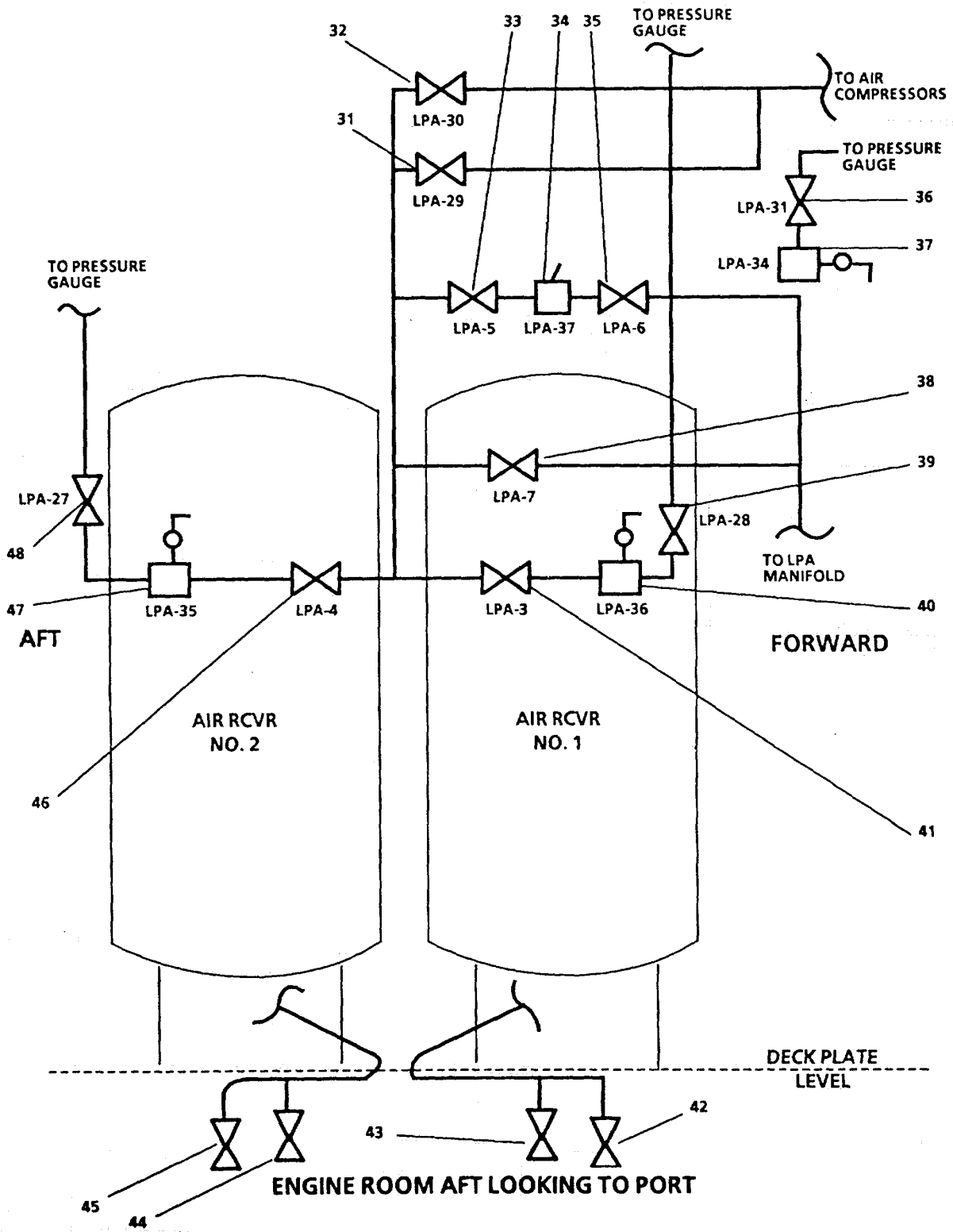

FIGURE 2-126. Compressed Air Piping System (Sheet 4 of 5).

**LEGEND**

- |  |   |
|--|---|
| 1. LPA-26, SUPPLY TO SVCE AIR          | 25. LPA-8, SUPPLY TO CONTROL AIR        |
| 2. LPA-24, SEA CHEST BLWDN             | 26. LPA-10, SUPPLY TO MN ENG-STBD       |
| 3. LPA-25, SUPPLY TO SVCE AIR          | 27. LPA-12, SUPPLY TO SSDG-PORT         |
| 4. LPA-23, SUPPLY TO FWD SVCE AIR      | 28. LPA-9, SUPPLY TO SVCE AIR           |
| 5. LPA-21, SUPPLY TO FWD SVCE AIR      | 29. LPA-11, SUPPLY TO MN ENG-STBD       |
| 6. LPA-22, SUPPLY TO SVCE AIR          | 30. LPA-13, MANIFOLD DRAIN              |
| 7. LPA-19, SEA CHEST BLWDN             | 31. LPA-29, TO AIR CPRSR UNLOADERS      |
| 8. LPA-15, SUPPLY TO MN ENG-STBD       | 32. LPA-30, PRESS SW                    |
| 9. LPA-17, SUPPLY TO SVCE AIR          | 33. LPA-5, SUPPLY TO PRESS RDCR         |
| 10. LPA-16, SUPPLY TO MN ENG-PORT      | 34. LPA-37, PRESS RDCR                  |
| 11. LPA-18, SUPPLY TO SSDG-PORT        | 35. LPA-6, SUPPLY TO MANIFOLD           |
| 12. LPA-14, SUPPLY TO SVCE AIR         | 36. LPA-31, PRESS GAGE                  |
| 13. LPA-20, SUPPLY TO SVCE AIR         | 37. LPA-34, RELIEF VLV                  |
| 14. CA-1, CONTROL AIR CUTOUT           | 38. LPA-7, BYPASS TO MANIFOLD           |
| 15. LPA-32, RELIEF VLV-AIR CPRSR NO. 1 | 39. LPA-28, PRESS GAGE-AIR RCVR NO. 1   |
| 16. LPA-1, DISCH-AIR CPRSR NO. 1       | 40. LPA-36, RELIEF VLV-AIR RCVR NO. 1   |
| 17. CA-2, ISLN-SEP/RGLTR               | 41. LPA-3, ISLN-AIR RCVR NO. 1          |
| 18. CA-3, SEP/RGLTR                    | 42. AIR RECEIVER DRAIN                  |
| 19. CA-4, SUPPLY TO CONTROL AIR        | 43. ISOLATION VALVE-AIR WATER SEPARATOR |
| 20. CA-7, SUPPLY TO CONTROL AIR        | 44. ISOLATION VALVE-AIR WATER SEPARATOR |
| 21. CA-6, SEP/RGLTR                    | 45. AIR RECEIVER DRAIN                  |
| 22. CA-5, ISLN-SEP/RGTR                | 46. LPA-4, ISLN-AIR RCVR NO. 2          |
| 23. LPA-2, DISCH-AIR CPRSR NO. 2       | 47. LPA-35, RELIEF VLV-AIR RCVR NO. 2   |
| 24. LPA-33, RELIEF VLV-AIR CPRSR NO. 2 | 48. LPA-27, PRESS GAGE-AIR RCVR NO. 2   |

FIGURE 2-126. Compressed Air Piping System (Sheet 5 of 5).

- (2) Open LPA-18 SUPPLY TO STARTER (11).

**NOTE**

If the LCU is in beached condition, ship service diesel generator will require its cooling system to be cooled from seawater (SW) tank #8, either port or starboard. When starboard SSDG was aligned for fresh water cooling into SW-8, cooling water flow for both generators is aligned.

- d. On port Ship Service Diesel Generator and Control Panel (FIGURE 2-127) set IDLE-RUN switch (5) to IDLE position.

- (1) Set START-RUN-OFF switch (4) to START position.  
 (2) Press CRANK pushbutton (3).

**CAUTION**

If engine fails to start within 30 seconds, release CRANK pushbutton.

- (3) Allow engine to idle for 3 to 5 minutes until WATER TEMP gauge (2) needle starts to rise.

**CAUTION**

If OIL PRESS gauge (1) needle does not rise to 45 psi within 15 seconds, stop engine or equipment damage could result. Notify unit maintenance.

**NOTE**

All diesel engines except main engines on the LCU have an Automatic Low Oil Pressure Shutdown System. This system will activate at a low oil pressure condition and shut engine down.

- (4) Set IDLE-RUN switch (5) to RUN position.  
 (5) On Main Switchboard (FIGURE 2-128), set AUTO OFF MANUAL switch (7) to AUTO POSITION.  
 (6) On port Ship Service Diesel Generator and Control Panel (FIGURE 2-127), set EXCITATION-SWITCH (6) to ON position.  
 (7) On Main Switchboard (FIGURE 2-128), adjust GENERATOR 2 3SPEED CONTROL (12) until GENERATOR 2 FREQUENCY METER (10) indicates 60 Hertz.  
 (a) Set VOLTMETER SWITCH (15) to phase of generation on GENERATOR 2 VOLTMETER (8).



- (b) Adjust GENERATOR 2 VOLTAGE ADJUST RHEOSTAT (13) to read 240 volts on GENERATOR 2 VOLTMETER (8).

**NOTE**

If generator is started with AUTO OFF MANUAL switch in MANUAL position, voltage adjustment is made by EXCITATION CONTROL (14).

- (c) Adjust GENERATOR 2 SPEED CONTROL (12) to read 60 Hertz on GENERATOR 2 FREQUENCY METER (10).
- (8) On Main Switchboard, set GENERATOR 2 CIRCUIT BREAKER as follows:
    - (a) Turn CIRCUIT BREAKER LOADING ARM (18) clockwise 90 degrees.
    - (b) Return LOADING ARM (18) to the vertical position.
- e. Parallel generator 2 to-generator 1.
- (1) On Main Switchboard, set SYNCHROSCOPE SWITCH (17) to GEN 2 position.
  - (2) Adjust GENERATOR 2 SPEED CONTROL (12), until pointer on SYNCHROSCOPE (6) is rotating in the FAST direction -clockwise).
  - (3) When SYNCHROSCOPE (6) pointer reaches top dead center, press CLOSE pushbutton (19) to release circuit breaker spring connecting generator No. 2 in parallel with generation No. 1.
  - (4) Adjust GENERATOR 2 SPEED CONTROL (12) to balance GENERATOR 2 WATTMETER (9) with GENERATOR 1 WATTMETER (4).
  - (5) Adjust GENERATOR 2 VOLTAGE ADJUST RHEOSTAT (13) to balance GENERATOR 2 AMMETER (11) with GENERATOR 1 AMMETER (5).
  - (6) Ensure GENERATOR 2 VOLTMETER (8) and GENERATOR 1 VOLTMETER (3) indicate 240 volts.
  - (7) Ensure GENERATOR 1 FREQUENCY METER (2) and GENERATOR 2 FREQUENCY METER (10) each indicate 60 Hertz, adjust GENERATOR 1 SPEED CONTROL (1) or GENERATOR 2 SPEED CONTROL (12) until balanced readings are obtained; maintain equal load on each generator.
  - (8) On Emergency Generator Diesel Engine Control Panel (FIGURE 2-129), set RUN-OFF-AUTO switch (1) to the AUTO position.
  - (9) On Emergency Switchboard (FIGURE 2-130), set MODE SWITCH (1) to AUTO position.
  - (10) On Emergency Generator Diesel Engine Control Panel (FIGURE 2-129) rotate EMERGENCY STOP switch (2) counterclockwise until it "pops" out.

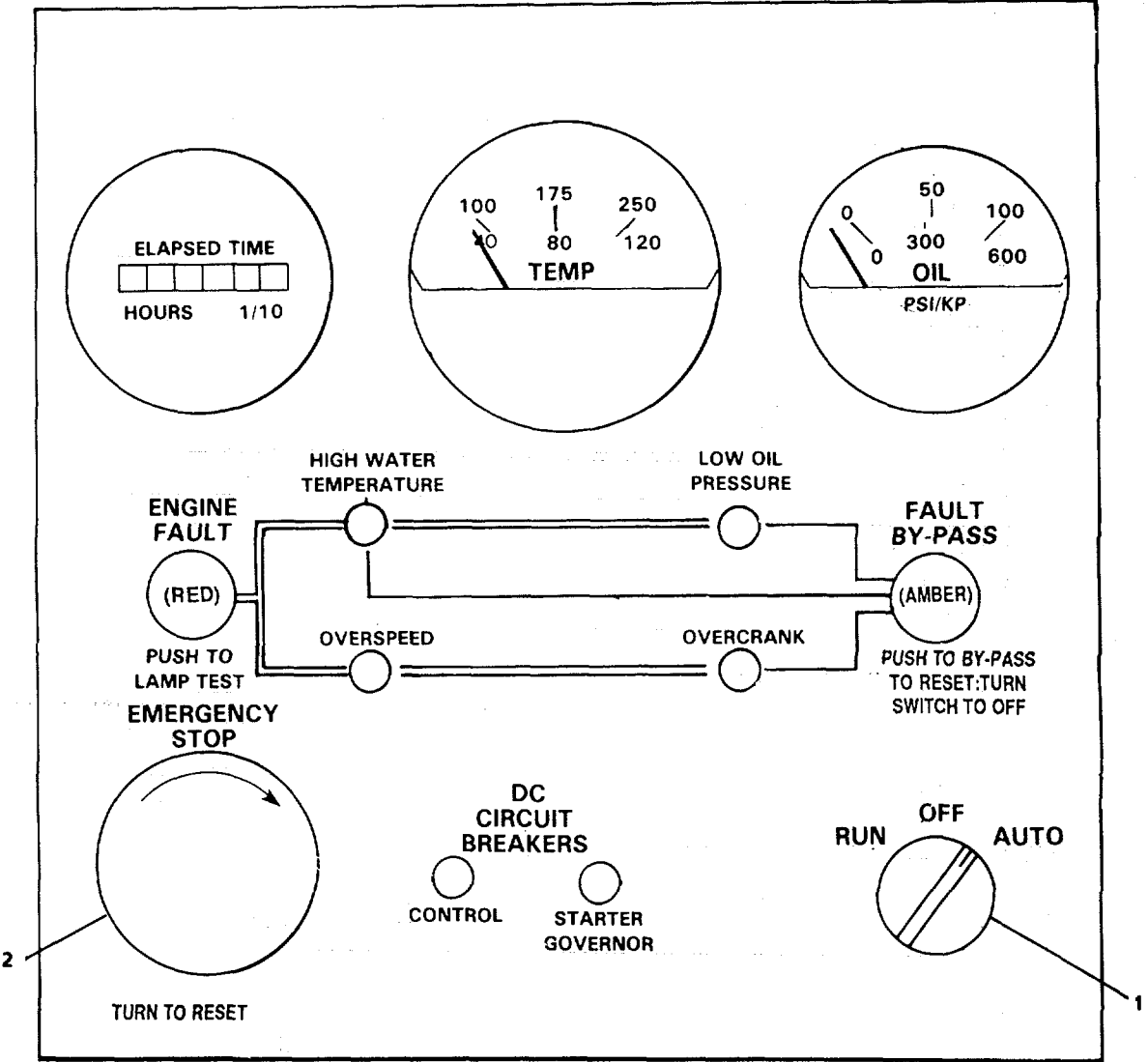

**LEGEND**

- 1. RUN-OFF AUTO SWITCH
- 2. EMERGENCY STOP SWITCH

FIGURE 2-129. Emergency Generator Diesel Engine Control Panel.

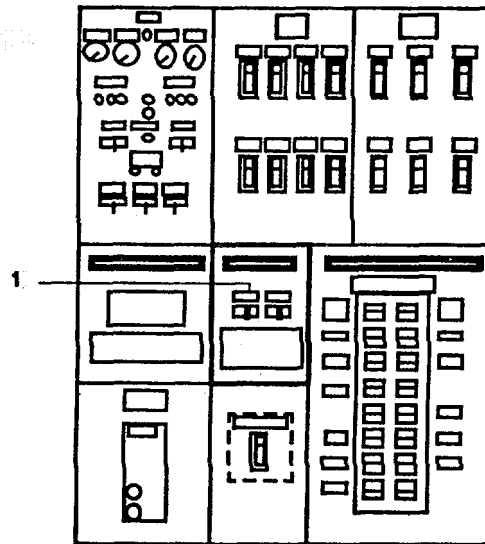
**LEGEND****1. MODE SWITCH***FIGURE 2-130. Emergency Switchboard.***2-12. Main Propulsion System****a. Starboard Main Engine**

- (1) Align Fuel Oil Filter, Transfer, and Supply Piping System (FIGURE 2-124) to the starboard main engine.
  - (a) Open STBD MN ENG FILTER INLET valves (13).
  - (b) Open STBD MN ENG FILTER DISCH valves (11).
  - (c) Open FO-37, RETURN FR STBD MN ENG TO DAY TK F-12S (14).

**NOTE**

FO-33, DAY TK F-12S SUPPLY TO STBD MN ENG & SSDG (17), was opened during alignment of fuel oil filter, transfer, and supply piping system for starting the Ship Service Diesel Generator.

- (2) Align Main Engines Fresh Water Cooling Piping System (FIGURE 2-131) to the starboard main engine.
  - (a) Open FWC-5, EXP-TK ENG STBD (4).
  - (b) Open FWC-1, SUPPLY-MN ENG STBD (2).
  - (c) Open FWC-3, RETURN-MN ENG STBD (3).

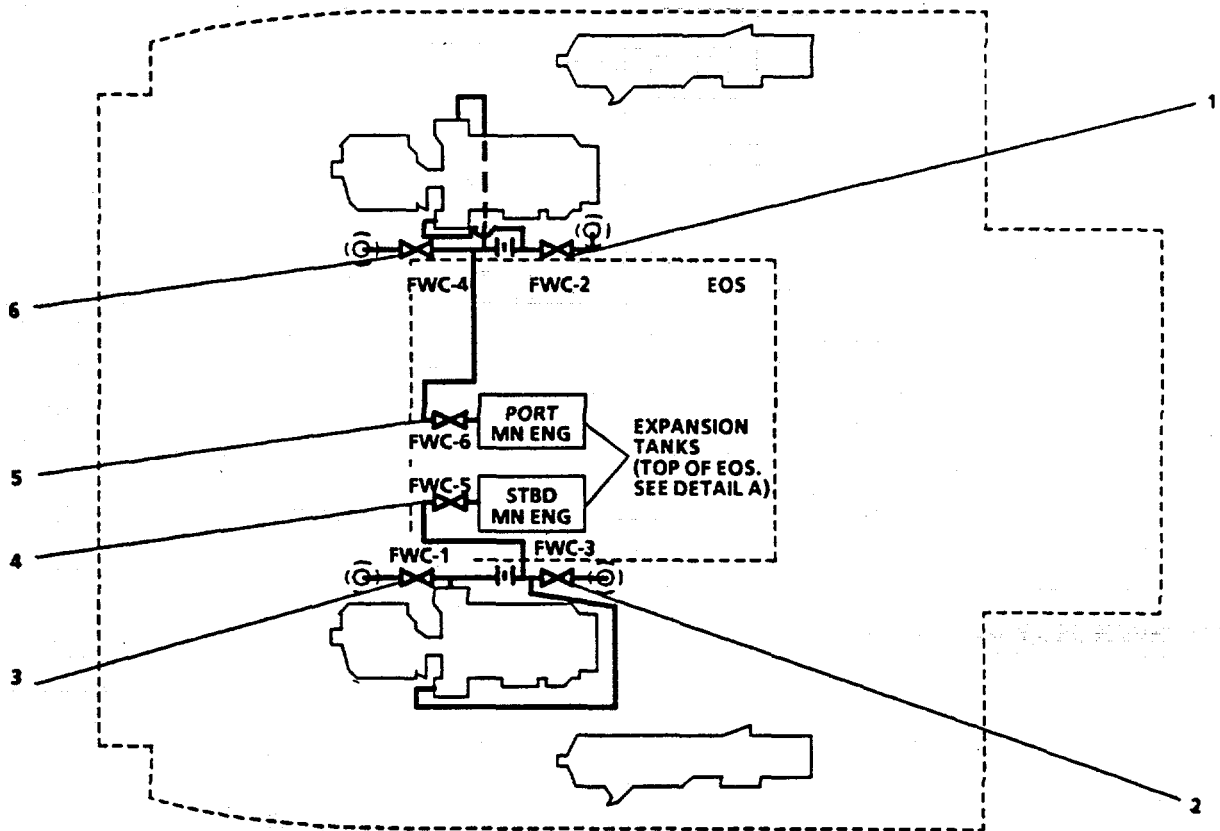

**LEGEND**

- |                              |                              |
|------------------------------|------------------------------|
| 1. FWC-2, SUPPLY-MN ENG PORT | 4. FWC-5, EXP TK-MN ENG STBD |
| 2. FWC-3, RETURN-MN ENG STBD | 5. FWC-6, EXP TK-MN ENG PORT |
| 3. FWC-1, SUPPLY-MN ENG STBD | 6. FWC-4, RETURN-MN ENG PORT |

FIGURE 2-131. Main Engines Fresh Water Piping System (Sheet 1 of 2).

DETAIL A

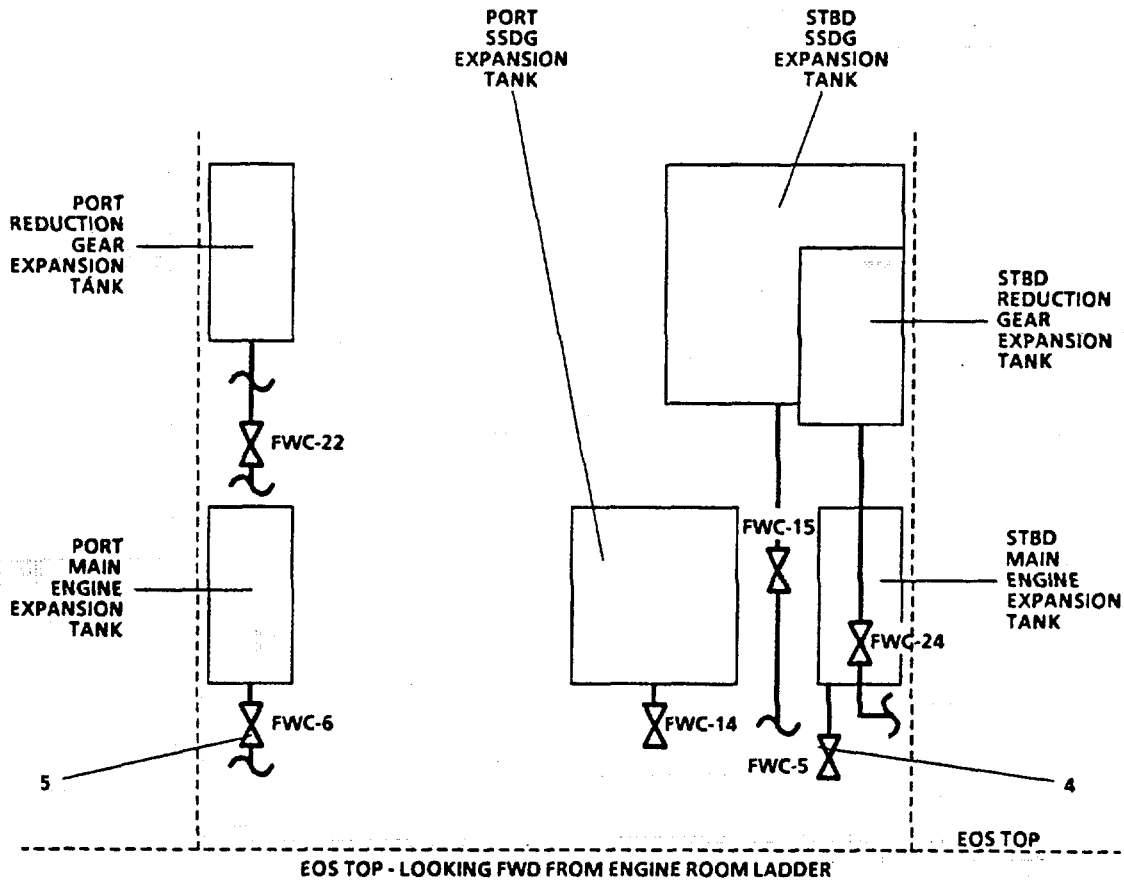

LEGEND

- 4. FWC-5, EXP TK-MN ENG STBD
- 5. FWC-6, EXP TK-MN ENG PORT

FIGURE 2-131. Main Engines Fresh Water Piping System (Sheet 2 of 2).

- (3) Align Reduction Gear Lube Oil Fresh Water Cooling Piping System to the starboard reduction gear (FIGURE 2-132).
  - (a) Open FWC-24, EXP TK-RDCN GEAR STBD (5).
  - (b) Open FWC-25, PRESS SW & PRESS GAUGE PUMP DISCH-RDCN GEAR STBD (9).
  - (c) Open FWC-23, PUMP DISCH-RDCN GEAR STBD (8).
  - (d) Open FWC-21, PUMP SUCT-RDCN GEAR STBD (6).
  - (e) Open FWC-19, RETURN TO KEEL CLR RDCN GEAR STBD (7).
  - (f) On Auxiliary Machinery Motor Control Center (FIGURE 2-133), set circuit breaker P205-7, REDUCTION GEAR COOLING WATER PUMP NO. 1 (2) to ON position.
  - (g) Press START (1, FIGURE 2-134) pushbutton on TYPE-I Motor Switch near Reduction Gear Cooling Water Pump No. 1.
  
- (4) Align Compressed Air Piping System (FIGURE 2-135) to the starboard main engine as follows:
  - (a) Open LPA-10, SUPPLY TO MN ENG-STBD (26).
  - (b) Open LPA-15, SUPPLY TO MN ENG-STBD (8).

**NOTE**

Engine Manufacturer recommends the engine be prelubed only if it has been shut down for 2 weeks or more. To prelube the engine, the following procedure is used.

- (5) Prelube STBD Main Engine as follows:
  - (a) Close all valves in the Lube Oil Purification and Transfer Piping System (FIGURE 2-136).
  - (b) Open LO-13, PRE-LUBE PUMP SUCT (25).
  - (c) Open LO-39, PRESSURE GAGE ISLN (24).
  - (d) Open LO-12, PRE-LUBE PUMP DISCH (26).
  - (e) Open LO-23, PRE-LUBE RETURN-STBD ENG (16).
  - (f) Open LO-19, SUMP SUCT-STBD ENG (17).
  - (g) Open LO-15, PRE-LUBE/PURIFIER SUCT (23).
  - (h) At Auxiliary Machinery Motor Control Center (FIGURE 2-133), set P205-9 PRE-LUBE PUMP circuit breaker (1) to ON position, press START (1, FIGURE 2-134) pushbutton on TYPE-I Motor Switch near prelube pump.

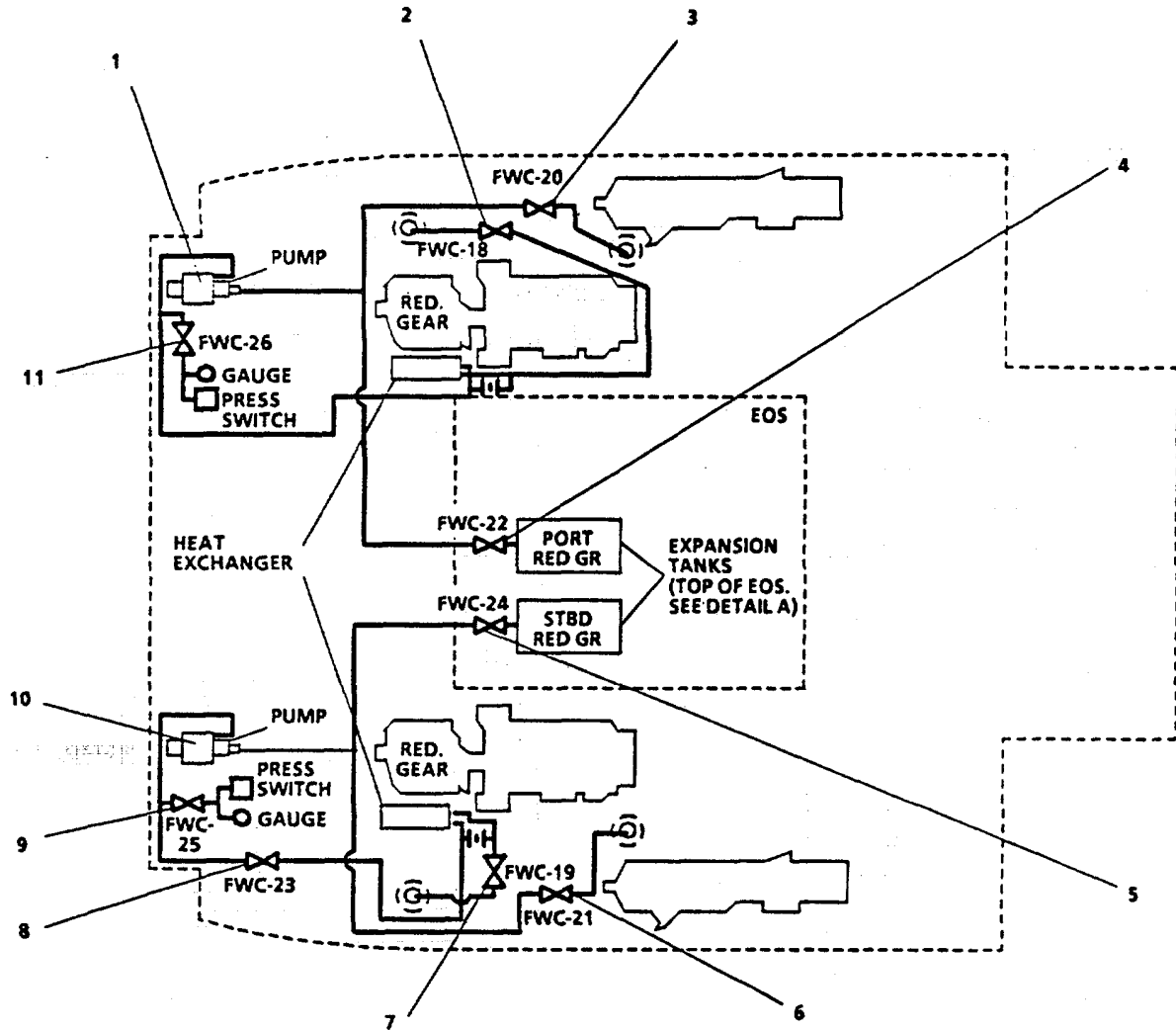

**LEGEND:**

- |  |  |
|--|--|
| 1. PORT RDCN GEAR COOLING PUMP               | 7. FWC-19, RETURN TO KEEL CLR RDCN GEAR STBD                         |
| 2. FWC-18, RETURN TO KEEL CLR RDCN GEAR PORT | 8. FWC-23, PUMP DISCH-RDCN GEAR STBD                                 |
| 3. FWC-20, PUMP SUCT-RDCN GEAR PORT          | 9. FWC-25, PRESS SW & PRESS GAGE PUMP DISCH-RDCN GEAR STBD           |
| 4. FWC-22, EXP TK-RDCN GEAR PORT             | 10. STBD RDCN GEAR COOLING PUMP                                      |
| 5. FWC-24, EXP TK-RDCN GEAR STBD             | 11. FWC-26, REDUCTION GEAR LUB OIL FRESH WATER COOLING PIPING SYSTEM |
| 6. FWC-21, PUMP SUCT-RDCN GEAR STBD          |  |

FIGURE 2-132. Reduction Gear Lube Oil Fresh Water Cooling Piping System (Sheet 1 of 2).

DETAIL A

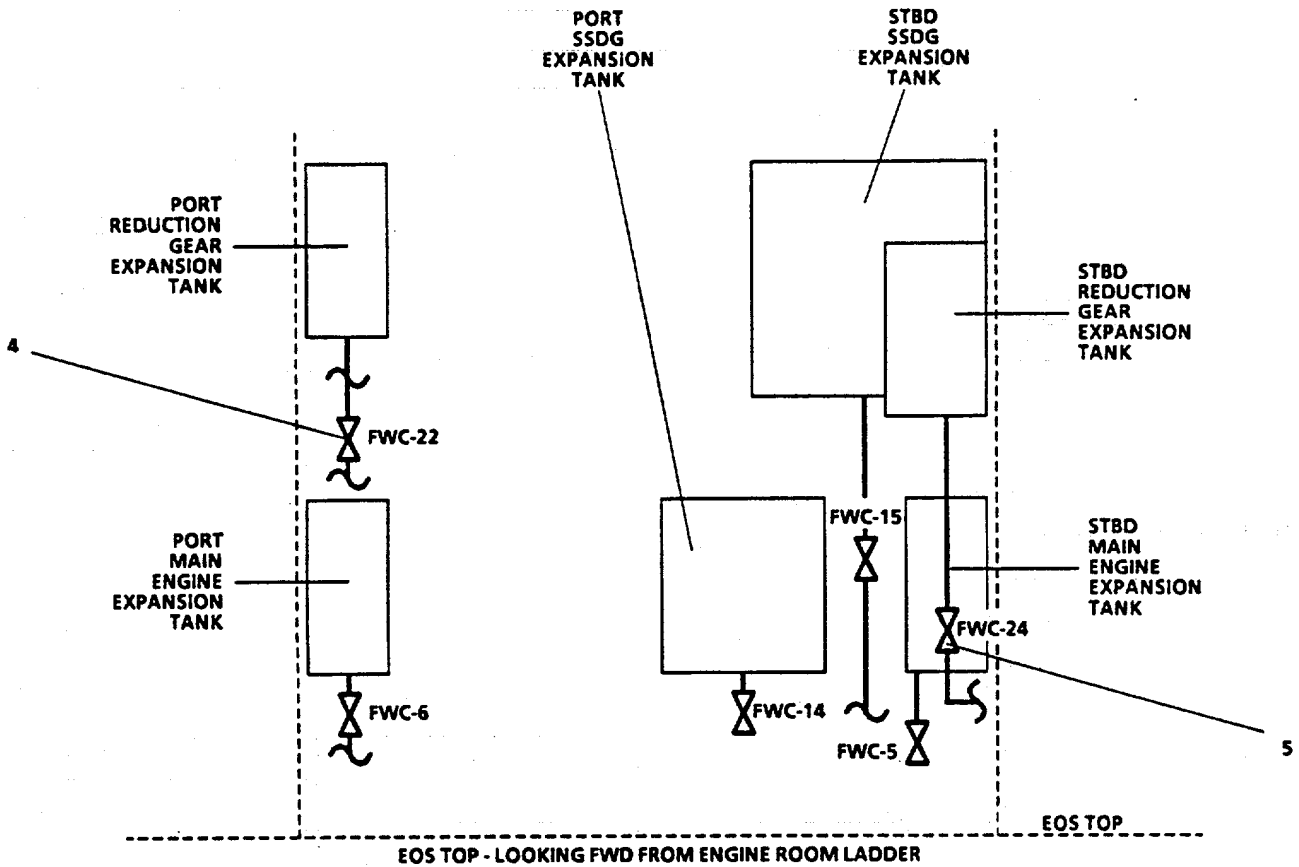

LEGEND:

- 4. FWC-22, EXP TK-RDCN GEAR PORT
- 5. FWC-24, EXP TK-RDCN GEAR STBD

FIGURE 2-132. Reduction Gear Lube Oil Fresh Water Cooling Piping System (Sheet 2 of 2).





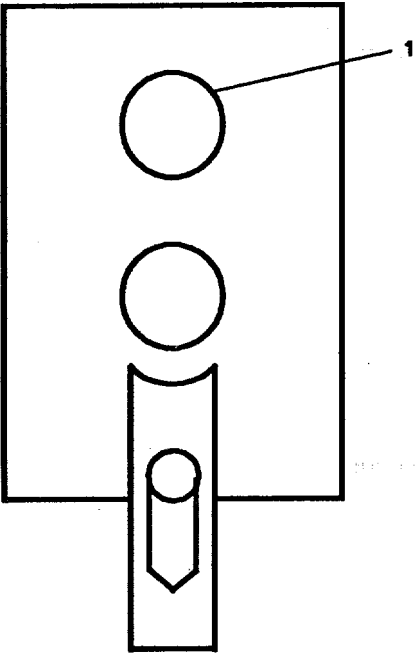

**LEGEND**  
1. **START**

*FIGURE 2-134. TYPE I Motor Switch.*

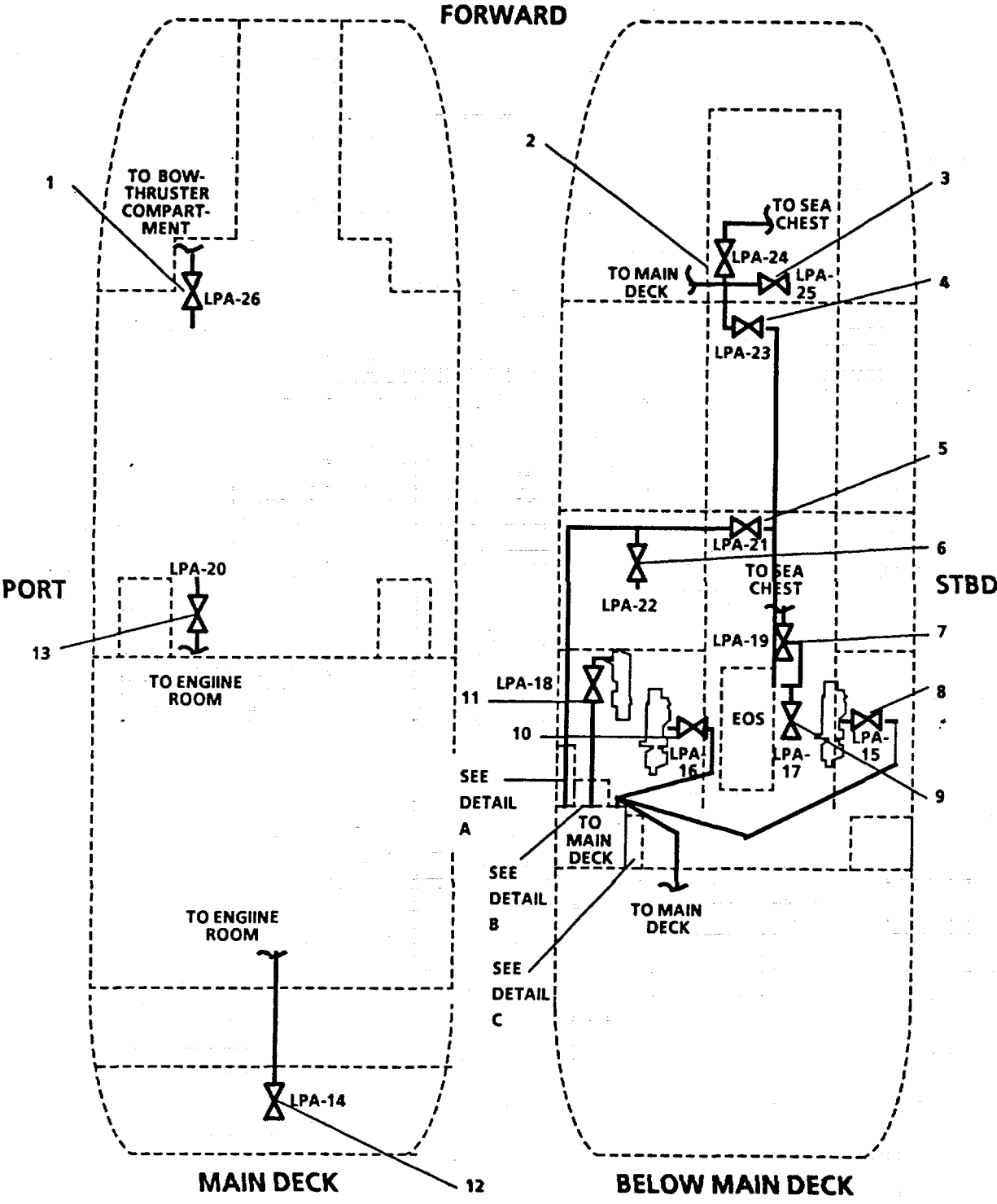

FIGURE 2-135. Compressed Air Piping System (Sheet 1 of 5).

DETAIL A

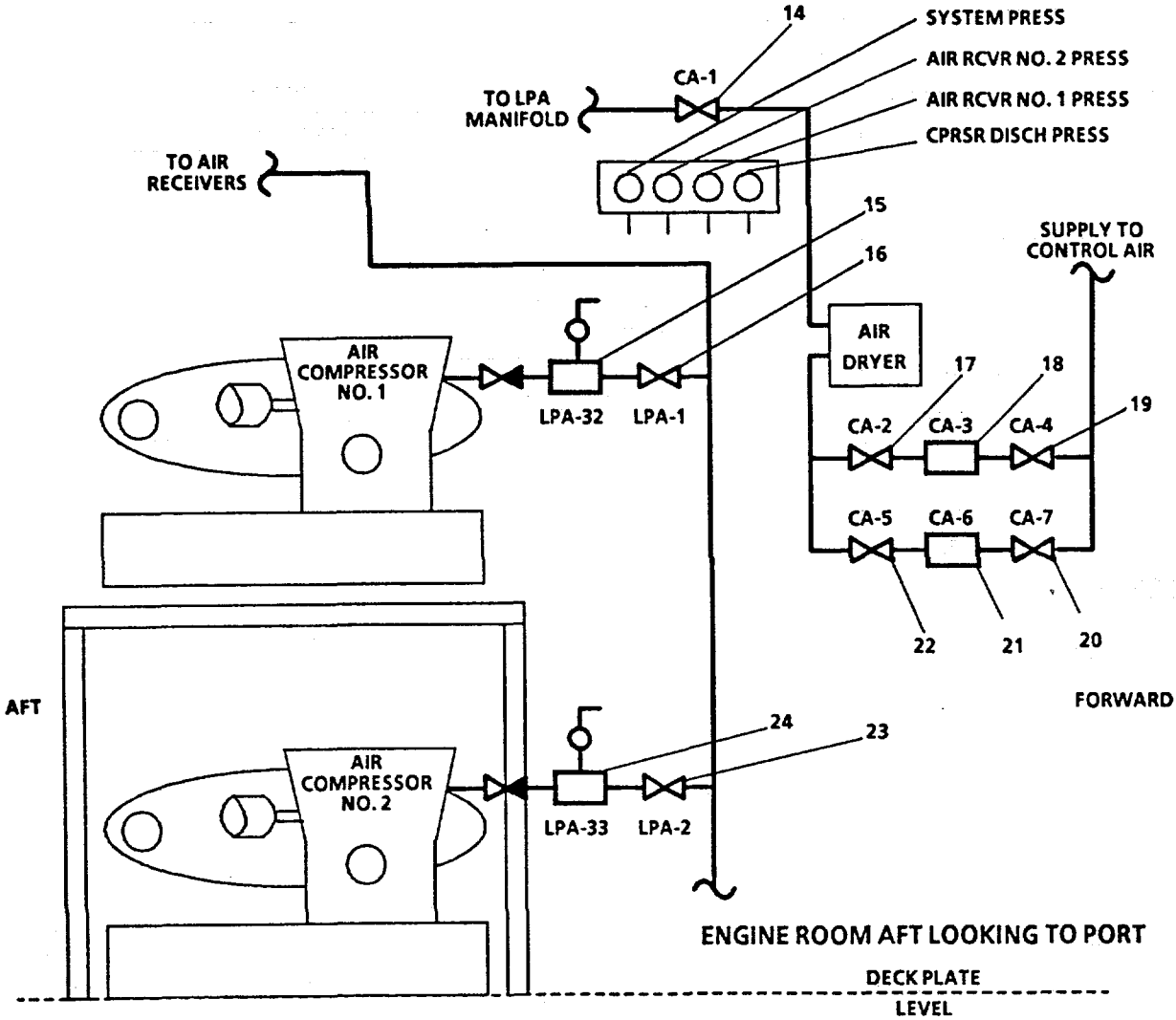

FIGURE 2-135. Compressed Air Piping System (Sheet 2 of 5).

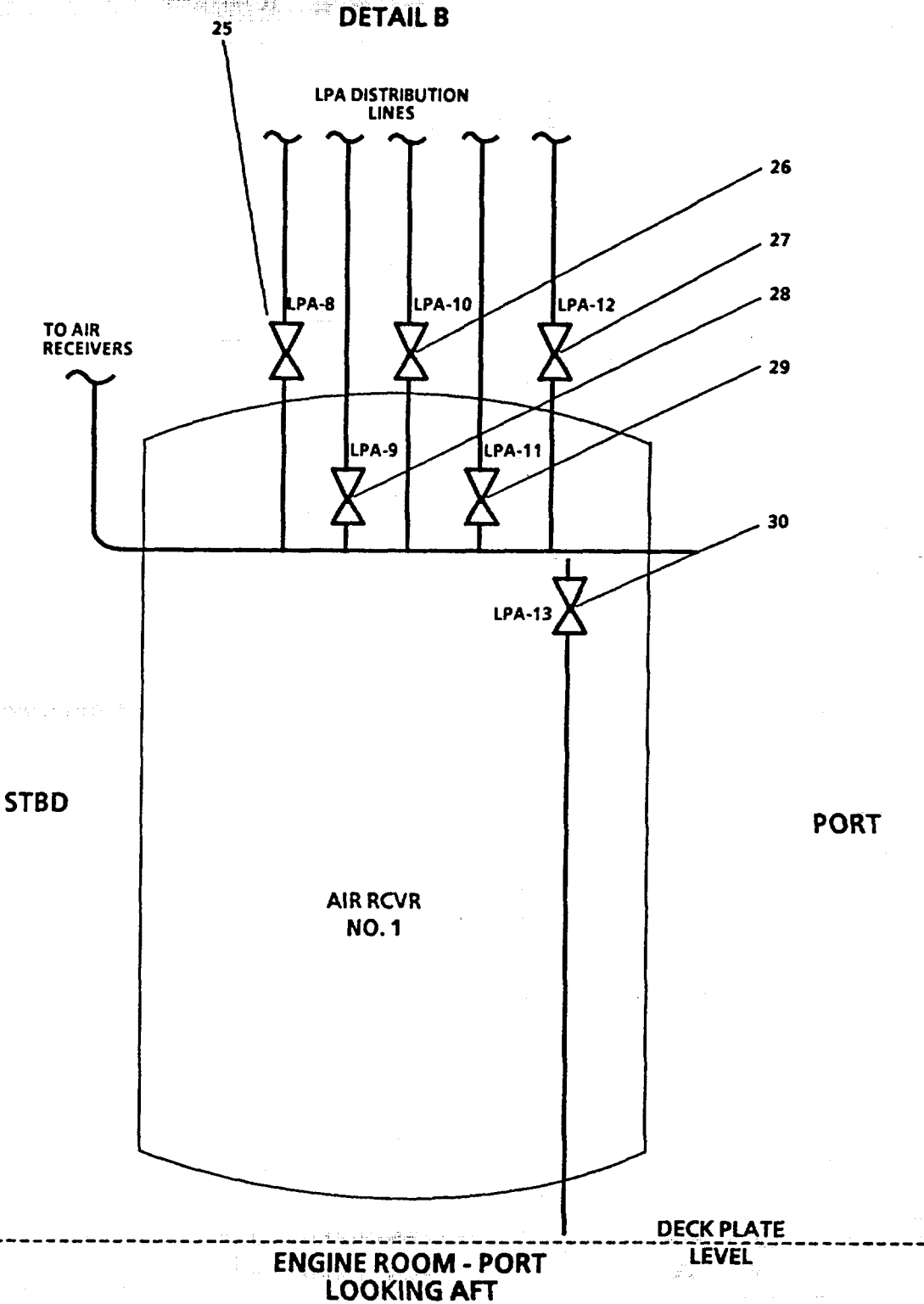

FIGURE 2-135. Compressed Air Piping System (Sheet 3 of 5).

DETAIL C

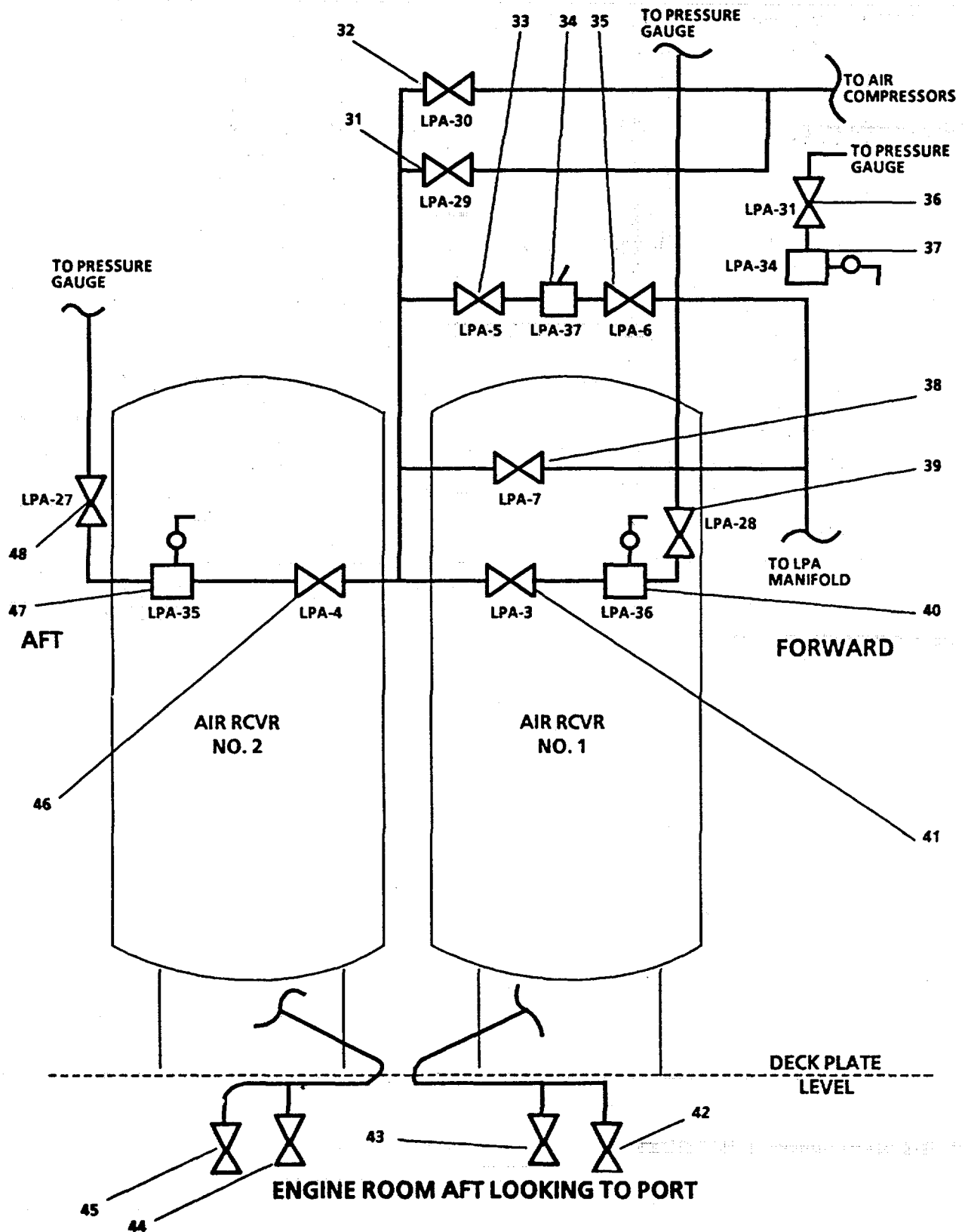
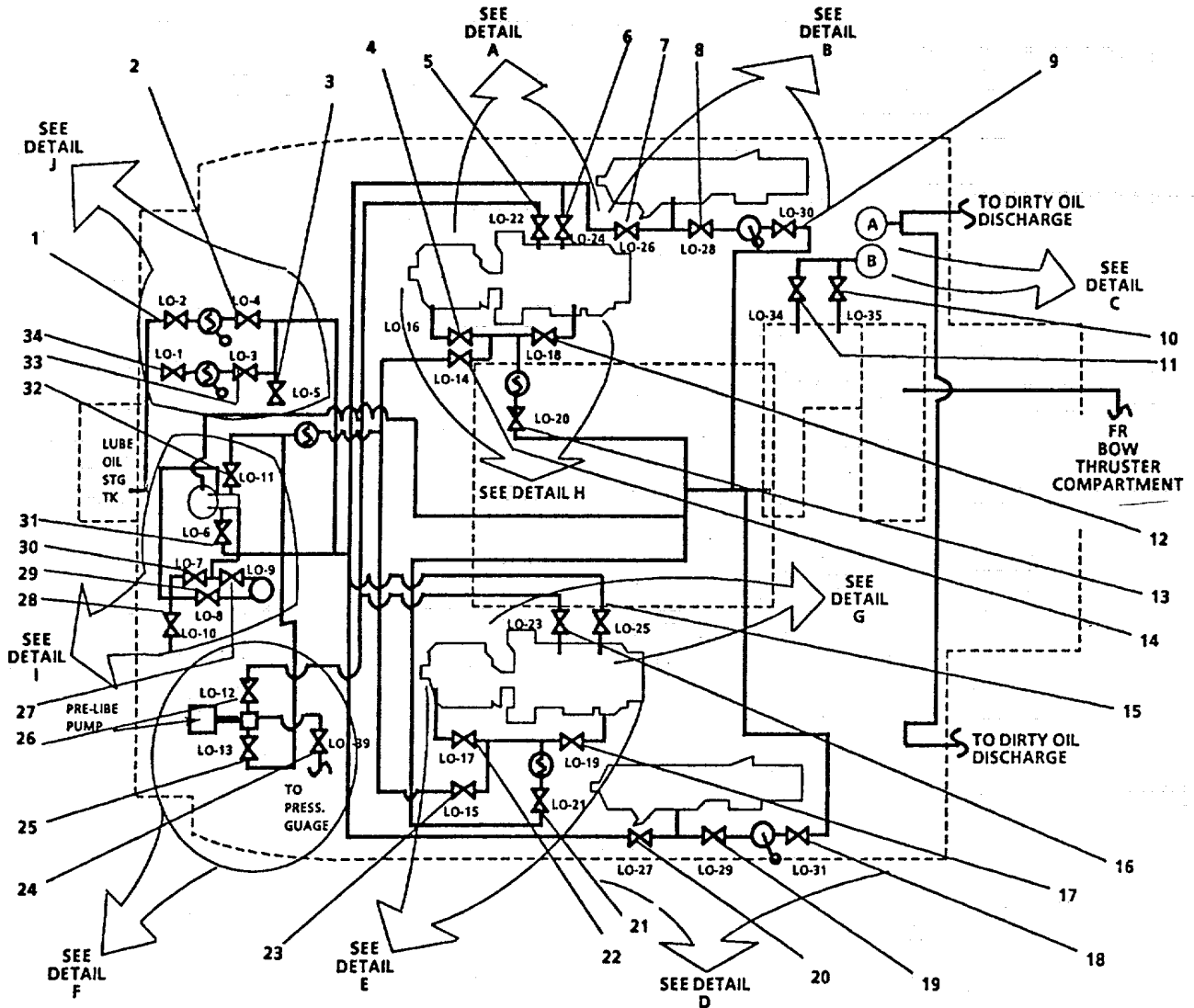

FIGURE 2-135. Compressed Air Piping System (Sheet 4 of 5).

**LEGEND**

- |  |   |
|--|---|
| 1. LPA-26, SUPPLY TO SVCE AIR          | 25. LPA-8, SUPPLY TO CONTROL AIR        |
| 2. LPA-24, SEA CHEST BLWDN             | 26. LPA-10, SUPPLY TO MN ENG-STBD       |
| 3. LPA-25, SUPPLY TO SVCE AIR          | 27. LPA-12, SUPPLY TO SSDG-PORT         |
| 4. LPA-23, SUPPLY TO FWD SVCE AIR      | 28. LPA-9, SUPPLY TO SVCE AIR           |
| 5. LPA-21, SUPPLY TO FWD SVCE AIR      | 29. LPA-11, SUPPLY TO MN ENG-STBD       |
| 6. LPA-22, SUPPLY TO SVCE AIR          | 30. LPA-13, MANIFOLD DRAIN              |
| 7. LPA-19, SEA CHEST BLWDN             | 31. LPA-29, TO AIR CPRSR UNLOADERS      |
| 8. LPA-15, SUPPLY TO MN ENG-STBD       | 32. LPA-30, PRESS SW                    |
| 9. LPA-17, SUPPLY TO SVCE AIR          | 33. LPA-5, SUPPLY TO PRESS RDCR         |
| 10. LPA-16, SUPPLY TO MN ENG-PORT      | 34. LPA-37, PRESS RDCR                  |
| 11. LPA-18, SUPPLY TO SSDG-PORT        | 35. LPA-6, SUPPLY TO MANIF              |
| 12. LPA-14, SUPPLY TO SVCE AIR         | 36. LPA-31, PRESS GAGE                  |
| 13. LPA-20, SUPPLY TO SVCE AIR         | 37. LPA-34, RELIEF VLV                  |
| 14. CA-1, CONTROL AIR CUTOUT           | 38. LPA-7, BYPASS TO MANF               |
| 15. LPA-32, RELIEF VLV-AIR CPRSR NO. 1 | 39. LPA-28, PRESS GAGE - AIR RCVR NO. 1 |
| 16. LPA-1, DISCH-AIR CPRSR NO. 1       | 40. LPA-36, RELIEF VLV-AIR RCVR NO. 1   |
| 17. CA-2, ISLN-SEP/RGLTR               | 41. LPA-3, ISLN-AIR RCVR NO. 1          |
| 18. CA-3, SEP/RGLTR                    | 42. AIR RECEIVER DRAIN                  |
| 19. CA-4, SUPPLY TO CONTROL AIR        | 43. ISOLATION VALVE-AIR WATER SEPARATOR |
| 20. CA-7, SUPPLY TO CONTROL AIR        | 44. ISOLATION VALVE-AIR WATER SEPARATOR |
| 21. CA-6, SEP/RGLTR                    | 45. AIR RECEIVER DRAIN                  |
| 22. CA-5, ISLN-SEP/RGTR                | 46. LPA-4, ISLN-AIR RCVR NO. 2          |
| 23. LPA-2, DISCH-AIR CPRSR NO. 2       | 47. LPA-35, RELIEF VLV-AIR RCVR NO. 2   |
| 24. LPA-33, RELIEF VLV-AIR CPRSR NO. 2 | 48. LPA-27, PRESS GAGE-AIR RCVR NO. 2   |

FIGURE 2-135. Compressed Air Piping System (Sheet 5 of 5).



**LEGEND**

- |    |  |    |                               |
|----|--|----|-------------------------------|
| 1  | LO-2, STORAGE TK SUPPLY                  | 21 | LO-21, MN ENG SUMP DISCH      |
| 2  | LO-4, HAND PUMP NO. 2 DISCH              | 22 | LO-17, RDCN GEAR SUCT-STBD    |
| 3  | LO-5, HAND SUPPLY                        | 23 | LO-15, PRE-LUBE PURIFIER SUCT |
| 4  | LO-16, RDCN GEAR SUCT-PORT               | 24 | LO-39, PRESSURE GAGE ISLN     |
| 5  | LO-22, PRE-LUBE RETURN-PORT ENG          | 25 | LO-13, PRE-LUBE PUMP SUCTION  |
| 6  | LO-24, SUMP SUPPLY/PURIFIER RTN-PORT ENG | 26 | LO-12, PRE-LUBE PUMP DISCH    |
| 7  | LO-26, SUMP SUPPLY                       | 27 | LO-9, PRE-HEATER SUPPLY       |
| 8  | LO-28, SUMP SUCT-SSDG                    | 28 | LO-10, PRE-HEATER VENT        |
| 9  | LO-30, SUMP DISCH-SSDG                   | 29 | LO-8, PRE-HEATER OUTLET       |
| 10 | LO-35, SLUDGE TK SUCT                    | 30 | LO-7, PRE-HEATER BY-PASS      |
| 11 | LO-34, DIRTY OIL TK SUCT                 | 31 | LO-6, LO PURIFIER DISCH       |
| 12 | LO-18-SUMP SUCT-PORT ENG                 | 32 | LO-11, PURIFIER SUCTION       |
| 13 | LO-20, MN ENG SUMP DISCH                 | 33 | LO-3, HAND PUMP NO. 1 DISCH   |
| 14 | LO-14, PRE-LUBE PURIFIER SUCT            | 34 | LO-1, STORAGE TK SUPPLY       |
| 15 | LO-25, SUMP SUPPLY/PURIFIER RTN-STBD ENG | 35 | LO-33, SUMP DISCH-BOW ENG     |
| 16 | LO-23, PRE-LUBE RETURN-STBD ENG          | 36 | HAND SUPPLY                   |
| 17 | LO-19, SUMP SUCT-STBD ENG                | 37 | LO-32, SUMP SUCT-BOW ENG      |
| 18 | LO-31, SUMP DISCH-SSDG                   | 38 | LO-37, DIRTY OIL PUMP DISCH   |
| 19 | LO-29, SUMP SUCT-SSDG                    | 39 | LO-36, DIRTY OIL PUMP SUCT    |
| 20 | LO-27, SUMP SUPPLY                       |    |                               |

FIGURE 2-136. Lube Oil Purification and Transfer Piping System (Sheet 1 of 8).



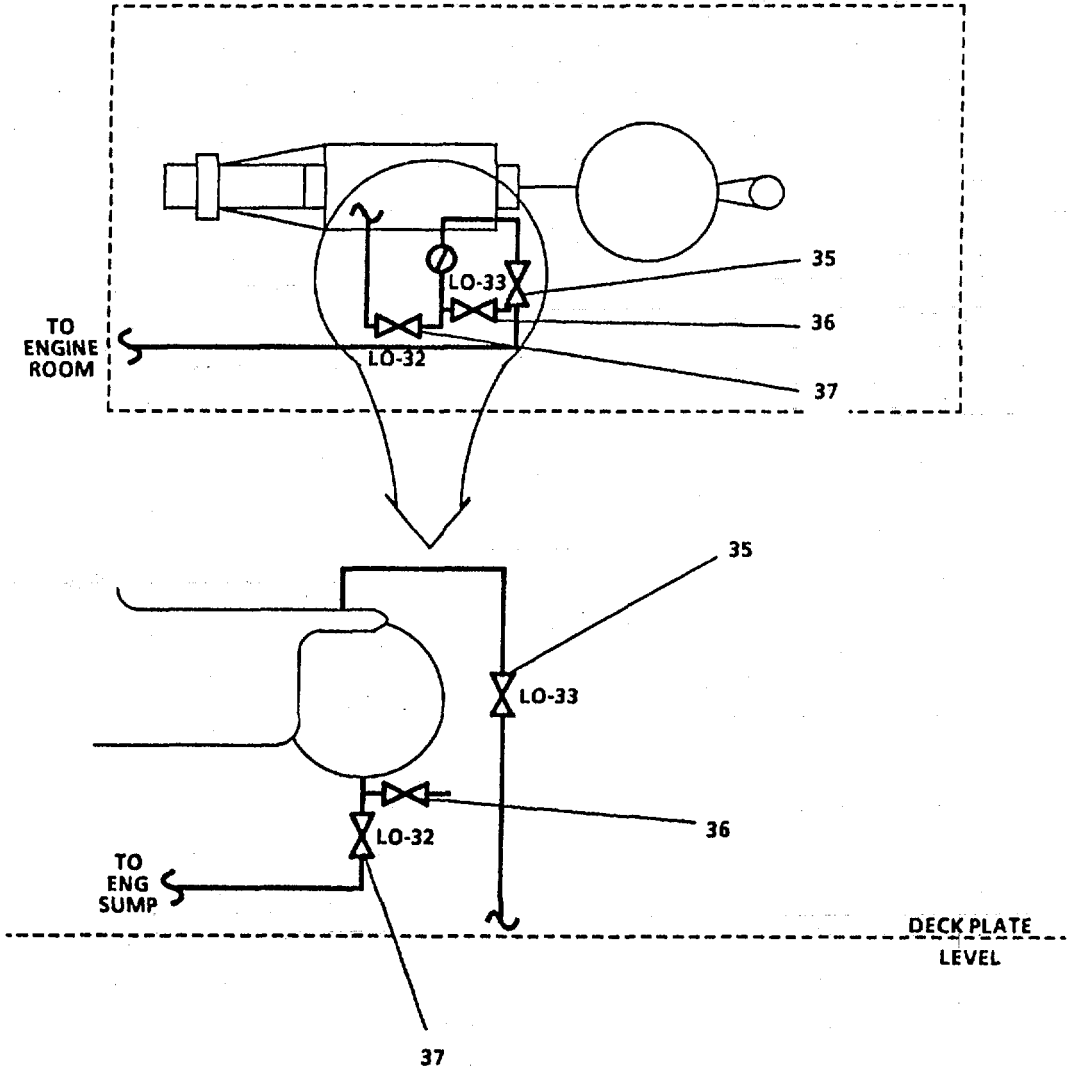
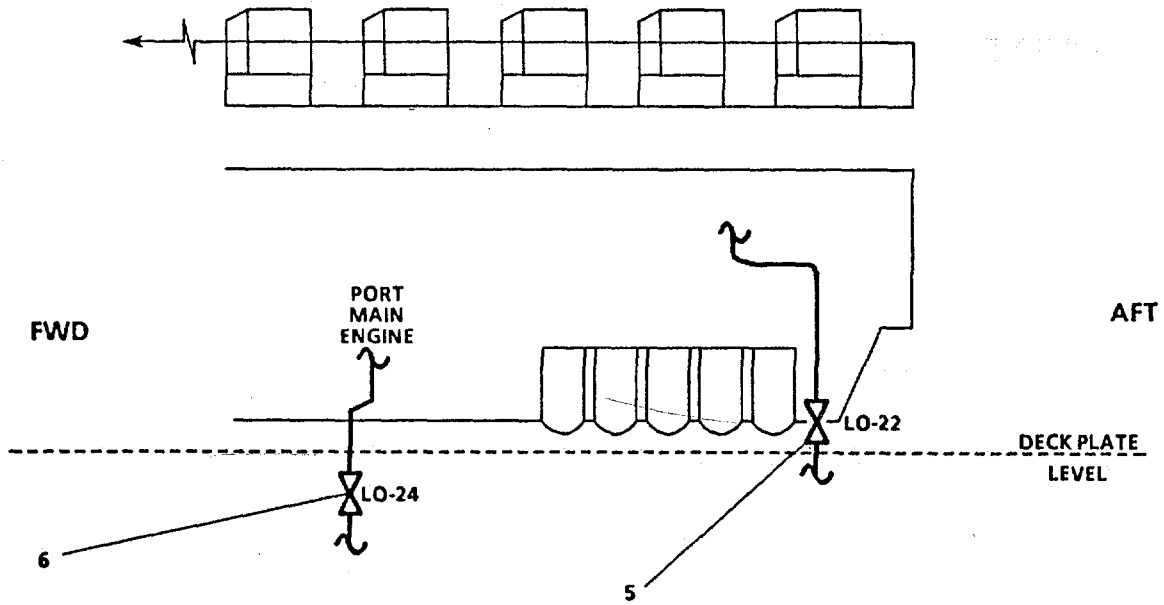

FIGURE 2-136. Lube oil Purification and Transfer Piping System (Sheet 2 of 8).

DETAIL A



DETAIL B

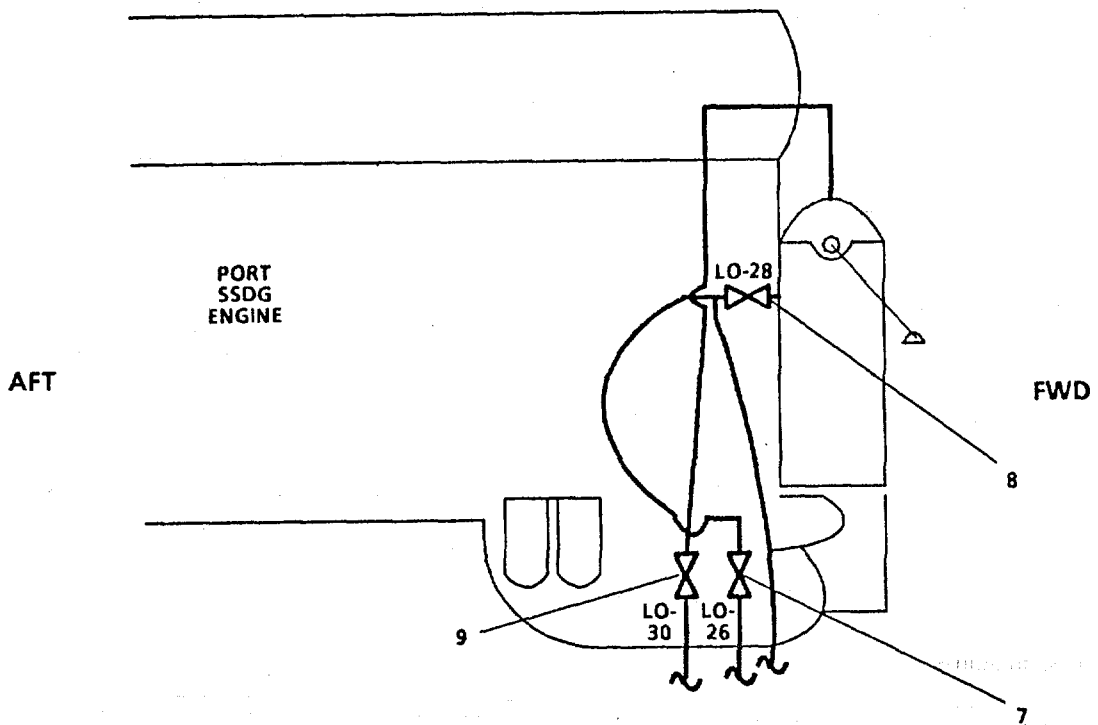

FIGURE 2-136. Lube Oil Purification and Transfer Piping System (Sheet 3 of 8).

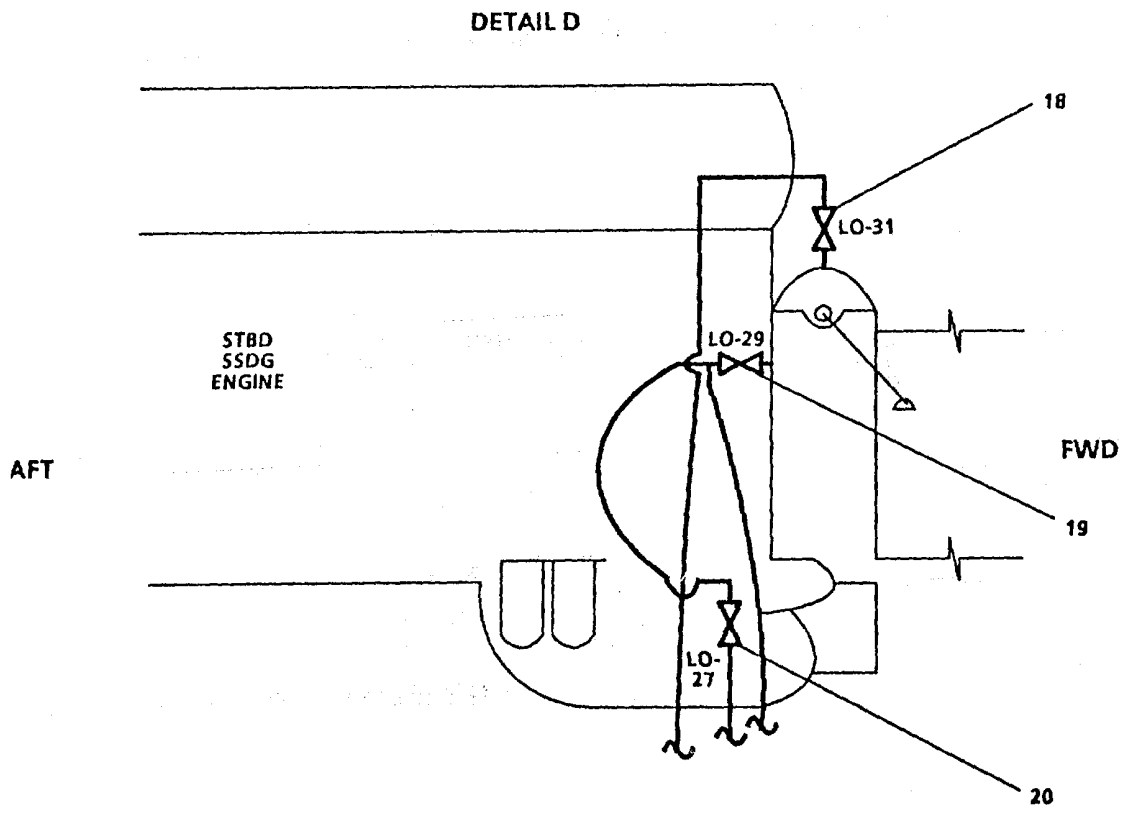
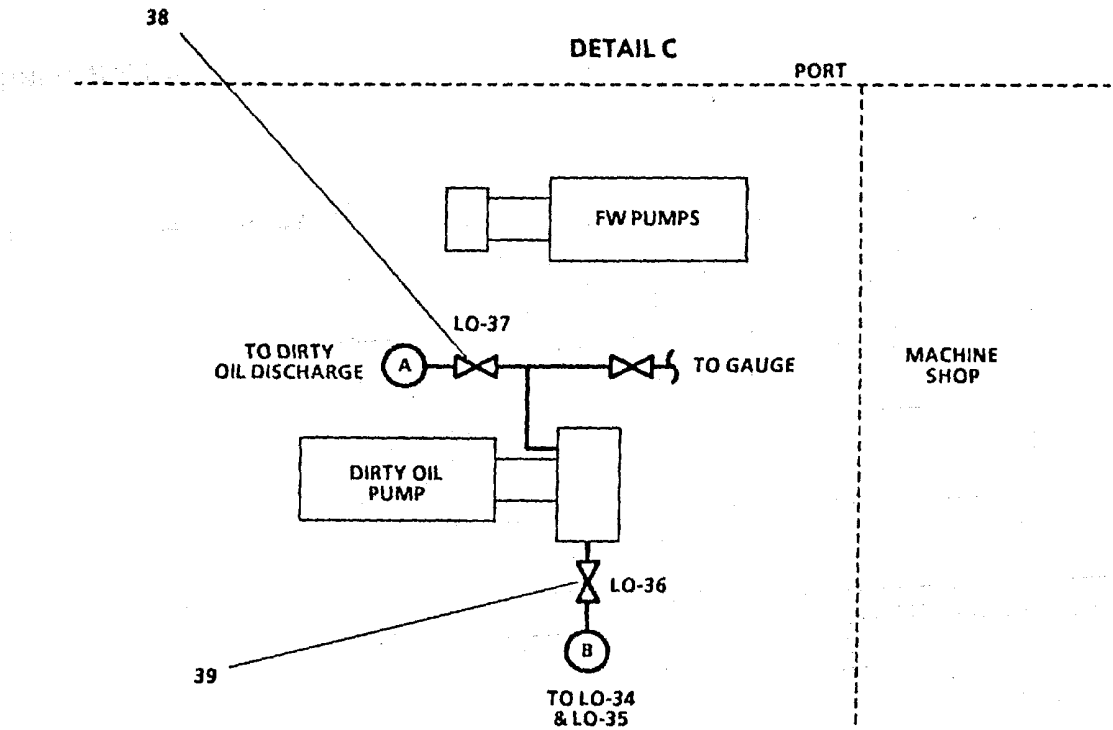

FIGURE 2-136. Lube Oil Purification and Transfer Piping System (Sheet 4 of 8).

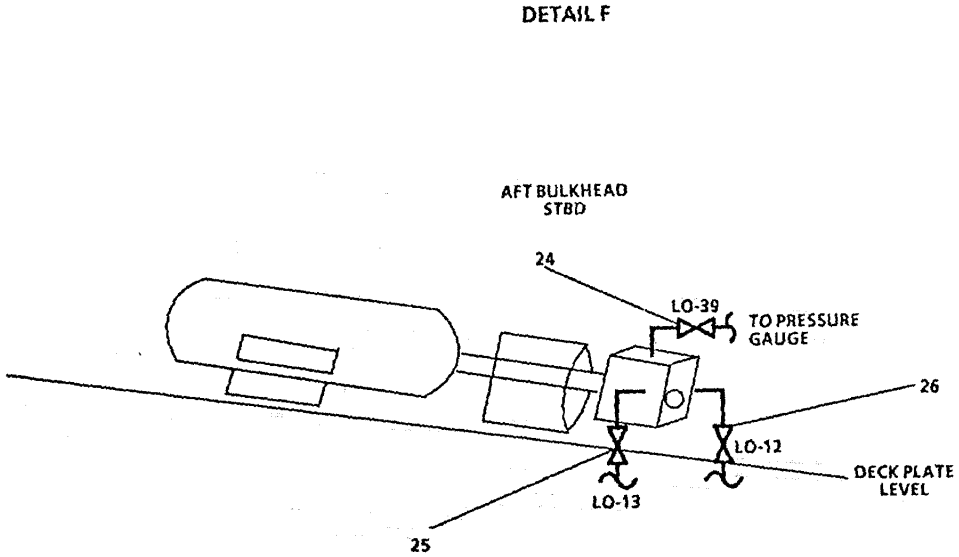
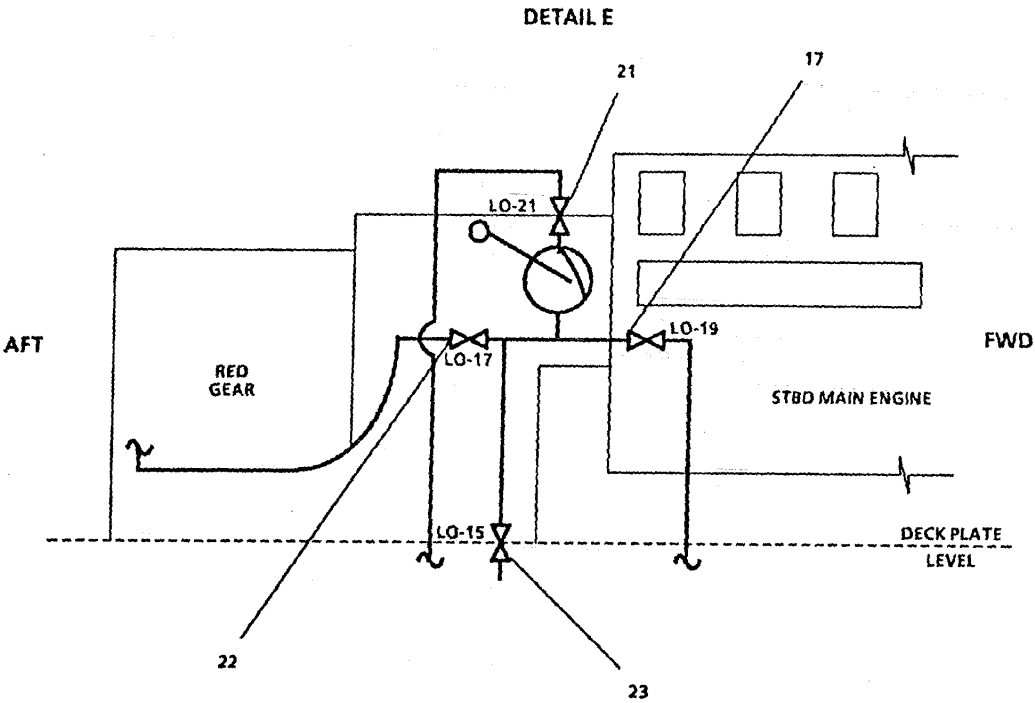
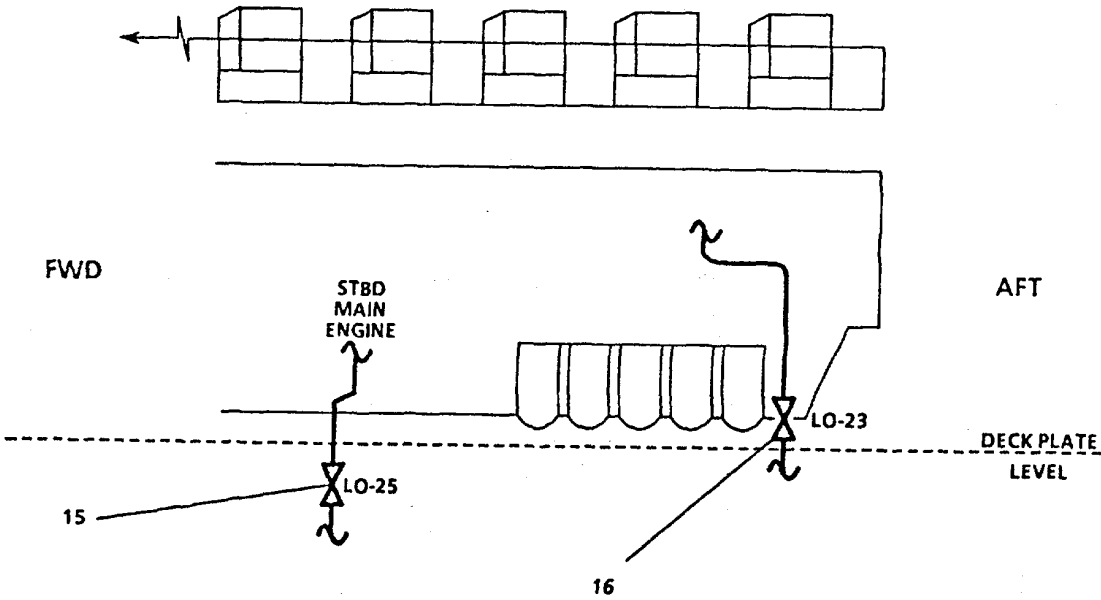

FIGURE 2-136. Lube Oil Purification and Transfer Piping System (Sheet 5 of 8).

DETAIL G



DETAIL H

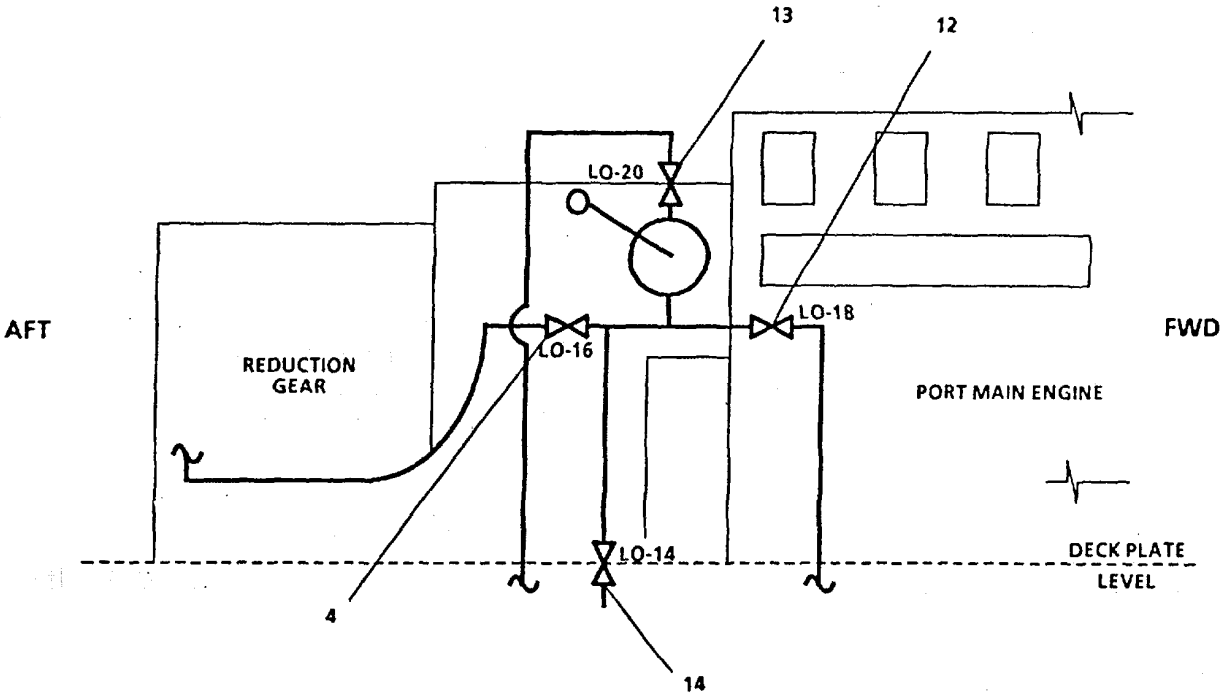

FIGURE 2-136. Lube Oil Purification and Transfer Piping System (Sheet 6 of 8).

DETAIL I  
LOOKING AFT

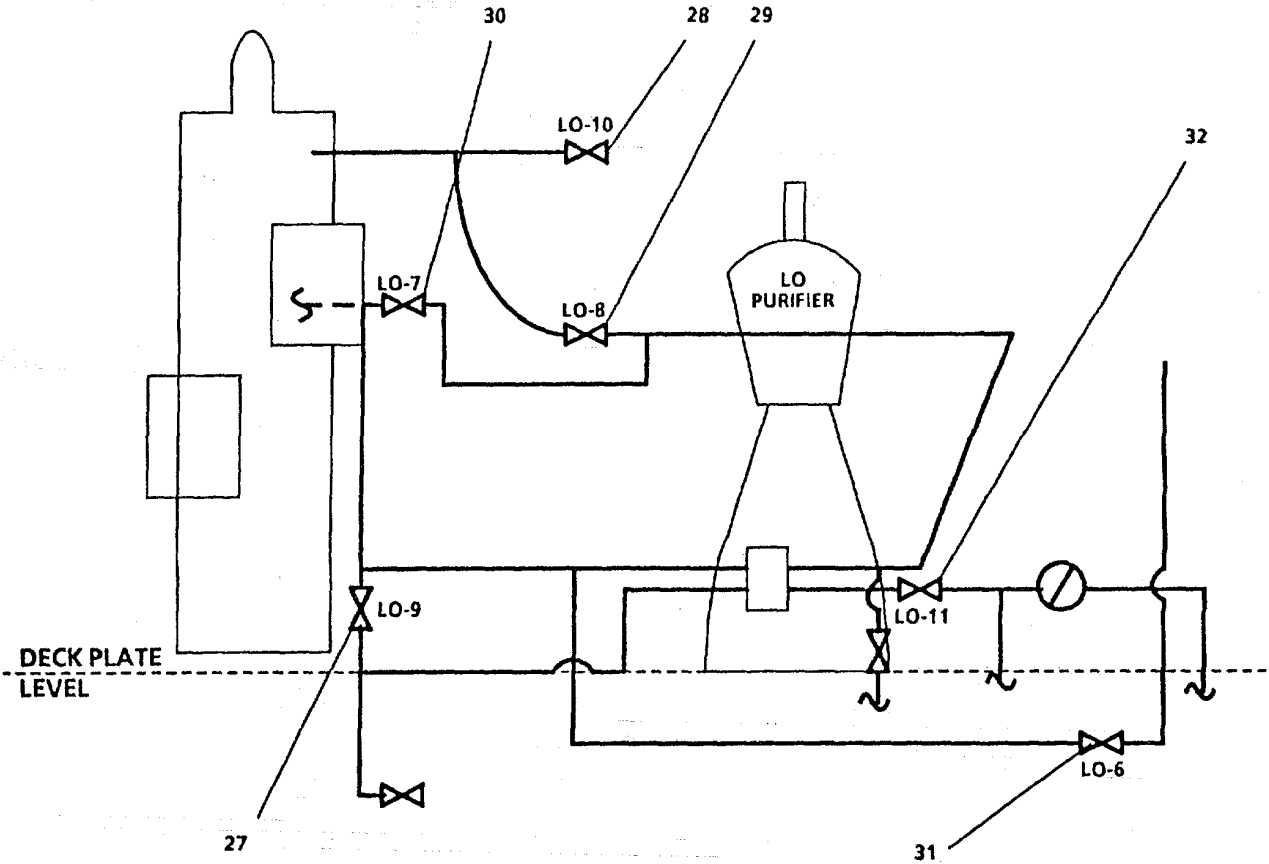
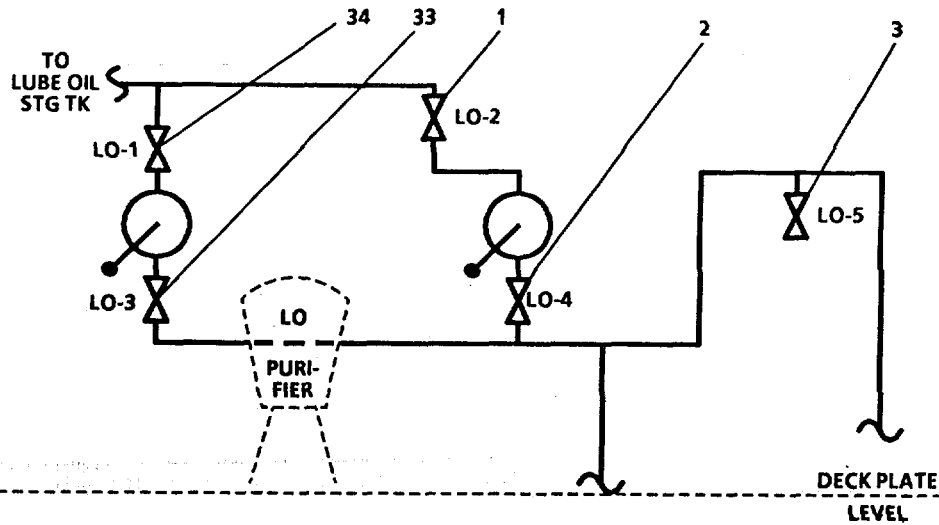

FIGURE 2-136. Lube Oil Purification and Transfer Piping System (Sheet 7 of 8).

DETAIL J



LEGEND

- |    |  |    |                               |
|----|--|----|-------------------------------|
| 1  | LO-2, STORAGE TK SUPPLY                  | 21 | LO-21, MN ENG SUMP DISCH      |
| 2  | LO-4, HAND PUMP NO. 2 DISCH              | 22 | LO-17, RDCN GEAR SUCT-STBD    |
| 3  | LO-5, HAND SUPPLY                        | 23 | LO-15, PRE-LUBE PURIFIER SUCT |
| 4  | LO-16, RDCN GEAR SUCT-PORT               | 24 | LO-39, PRESSURE GAGE ISLN     |
| 5  | LO-22, PRE-LUBE RETURN-PORT ENG          | 25 | LO-13, PRE-LUBE PUMP SUCTION  |
| 6  | LO-24, SUMP SUPPLY/PURIFIER RTN-PORT ENG | 26 | LO-12, PRE-LUBE PUMP DISCH    |
| 7  | LO-26, SUMP SUPPLY                       | 27 | LO-9, PRE-HEATER SUPPLY       |
| 8  | LO-28, SUMP SUCT-SSDG                    | 28 | LO-10, PRE-HEATER VENT        |
| 9  | LO-30, SUMP DISCH-SSDG                   | 29 | LO-8, PRE-HEATER OUTLET       |
| 10 | LO-35, SLUDGE TK SUCT                    | 30 | LO-7, PRE-HEATER BY-PASS      |
| 11 | LO-34, DIRTY OIL TK SUCT                 | 31 | LO-6, LO PURIFIER DISCH       |
| 12 | LO-18-SUMP SUCT-PORT ENG                 | 32 | LO-11, PURIFIER SUCTION       |
| 13 | LO-20, MN ENG SUMP DISCH                 | 33 | LO-3, HAND PUMP NO. 1 DISCH   |
| 14 | LO-14, PRE-LUBE PURIFIER SUCT            | 34 | LO-1, STORAGE TK SUPPLY       |
| 15 | LO-25, SUMP SUPPLY/PURIFIER RTN-STBD ENG | 35 | LO-33, SUMP DISCH-BOW ENG     |
| 16 | LO-23, PRE-LUBE RETURN-STBD ENG          | 36 | HAND SUPPLY                   |
| 17 | LO-19, SUMP SUCT-STBD ENG                | 37 | LO-32, SUMP SUCT-BOW ENG      |
| 18 | LO-31, SUMP DISCH-SSDG                   | 38 | LO-37, DIRTY OIL PUMP DISCH   |
| 19 | LO-29, SUMP SUCT-SSDG                    | 39 | LO-36, DIRTY OIL PUMP SUCT    |
| 20 | LO-27, SUMP SUPPLY                       |    |                               |

FIGURE 2-136. Lube Oil Purification and Transfer Piping System (Sheet 8 of 8).

(i) In Engine Room Operating Station on Engine Room Console Panel (FIGURE 2-137) press + page pushbutton (1) until main engine oil pressure (PAGE 2) appears on MCHRY PLANT MONITOR. When the display indicates 3 to 4 psi, press STOP pushbutton (2) on the Auxiliary Machinery Motor Control Center (FIGURE 2-133) or press STOP (2, FIGURE 2-134) on TYPE-I Motor Switch near prelube pump.

(j) Close all valves in the lube oil purification and transfer piping system (FIGURE 2-136).

(6) Start starboard main engine.

(a) At starboard Main Engine Control Panel (FIGURE 2-138), START AIR PRESSURE gauge (3) needle indicates 125 psi.

(b) Set REMOTE START CUTOFF SWITCH (6) for local operation.

(c) Set POWER SWITCH EMERGENCY STOP switch (5) to UP position.

(d) Press PUSH TO START ENGINE START pushbutton (4).

**NOTE**

Engine should start within 10 seconds.

(e) Release PUSH TO START ENGINE START pushbutton (4).

(f) Monitor ENGINE OIL PRESSURE gauge (1, 20 to 70 psi), ENGINE OIL TEMP gauge (8, 1750 to 1950F), and ENGINE WATER TEMP gauge (7, 1600F to 2030F).

**b. Port Main Engine.**

(1) Align Fuel Oil Filter, Transfer, and Supply Piping System (FIGURE 2-139) to the port main engine.

(a) Open FO-36, DAY TK F-12P SUPPLY TO PORT MN ENG & SSDG (22).

(b) Open PORT MN ENG FILTER INLET valves (13).

(c) Open PORT MN ENG FILTER DISCH valves (11).

(d) Open FO-38, RETURN FR PORT MN ENG TO DAY TK.F-12P (25).

(2) Align Main Engines Fresh Water Cooling Piping System (FIGURE 2-140) to Port Main Engine.

(a) Open FWC-6, EXP TK-MN ENG PORT (5).

(b) Open FWC-2, SUPPLY-MN ENG PORT (1).

(c) Open FWC-4, RETURN-MN ENG PORT (6).

(3) Align Reduction Gear Lube Oil Freshwater Cooling Piping System (FIGURE 2-141) to port reduction gear.



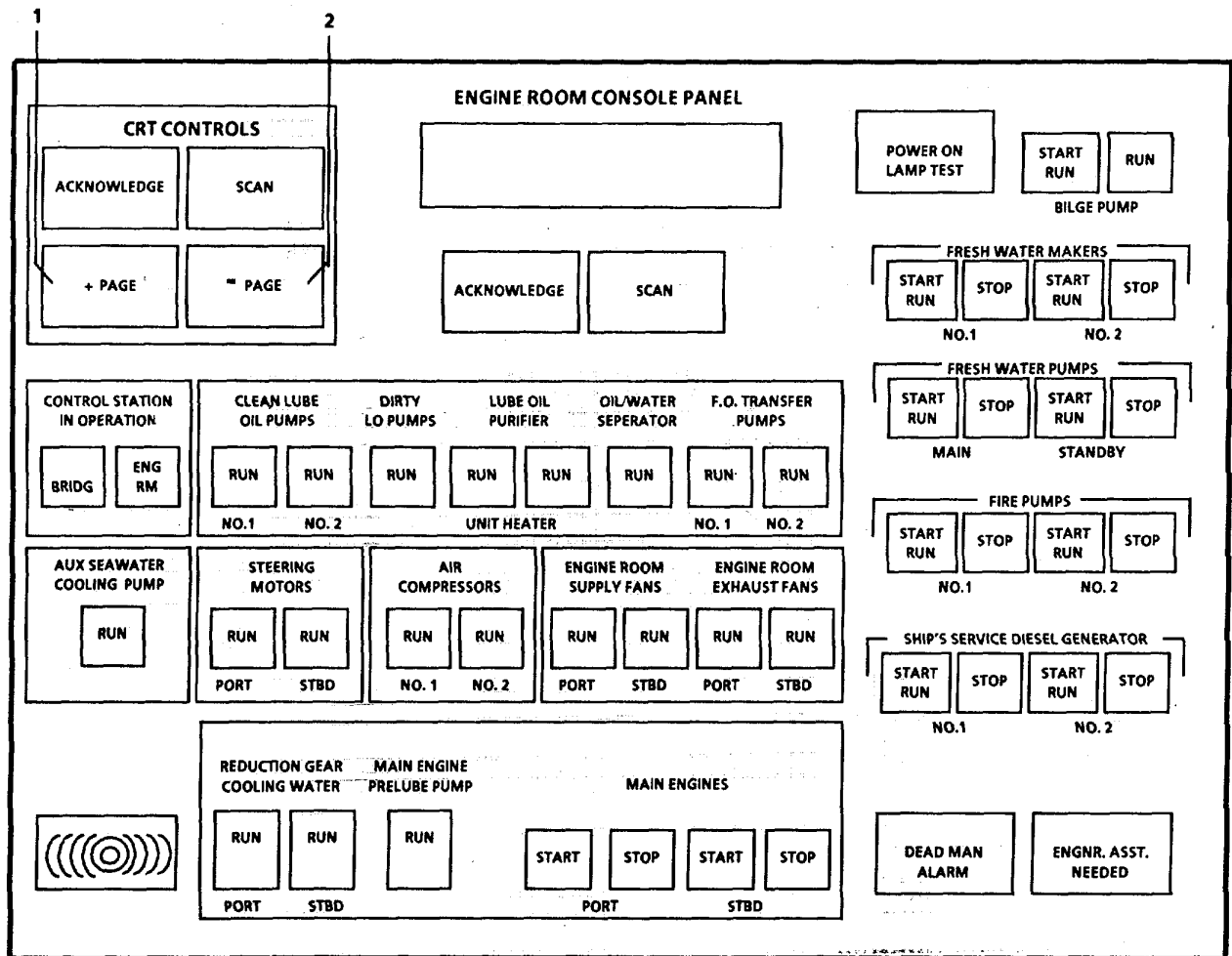

**LEGEND**

- 1. + PAGE
- 2. - PAGE

FIGURE 2-138. Main Engine Control Panel.

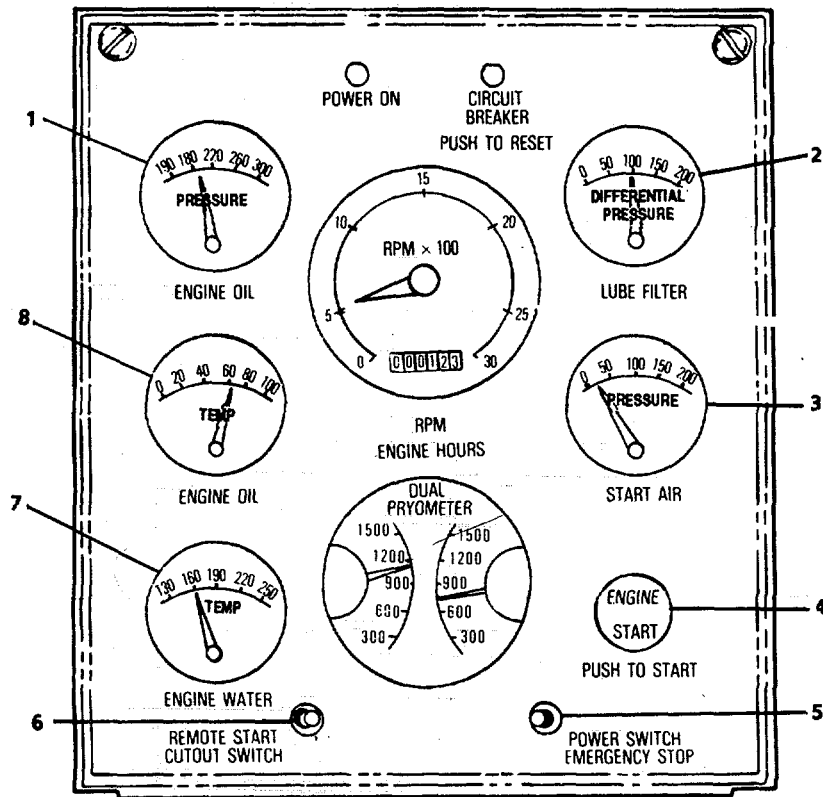

**LEGEND**

- |                                      |                                |
|--------------------------------------|--------------------------------|
| 1. ENGINE OIL PRESSURE               | 5. POWER SWITCH EMERGENCY STOP |
| 2. LUBE FILTER DIFFERENTIAL PRESSURE | 6. REMOTE START CUTOUT SWITCH  |
| 3. START AIR PRESSURE                | 7. ENGINE WATER TEMP           |
| 4. PUSH TO START ENGINE START        | 8. ENGINE OIL TEMP             |

FIGURE 2-138. Main Engine Control Panel.

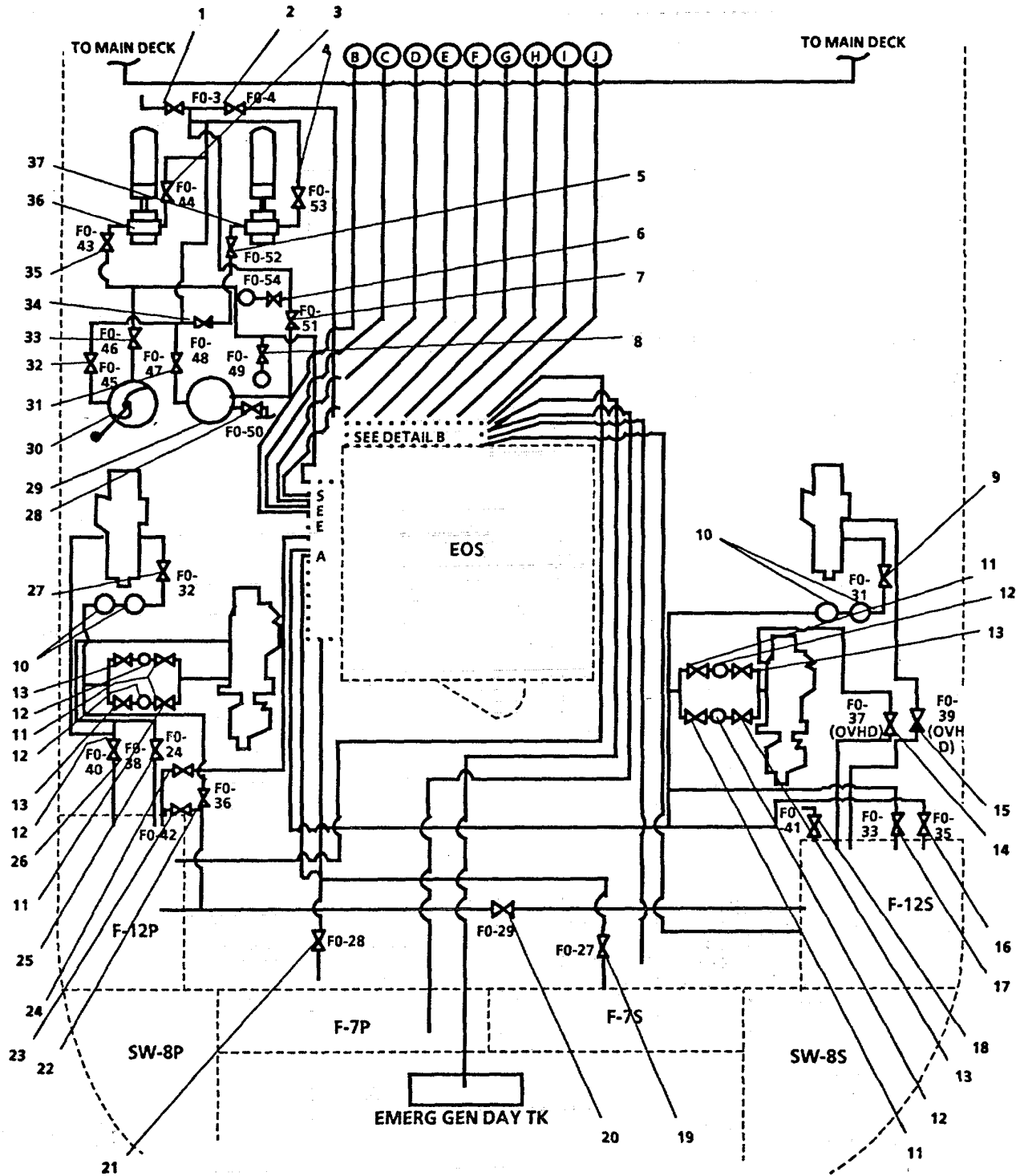

FIGURE 2-139. Fuel Oil Filter, Transfer and Supply Piping System (Sheet 1 of 6).

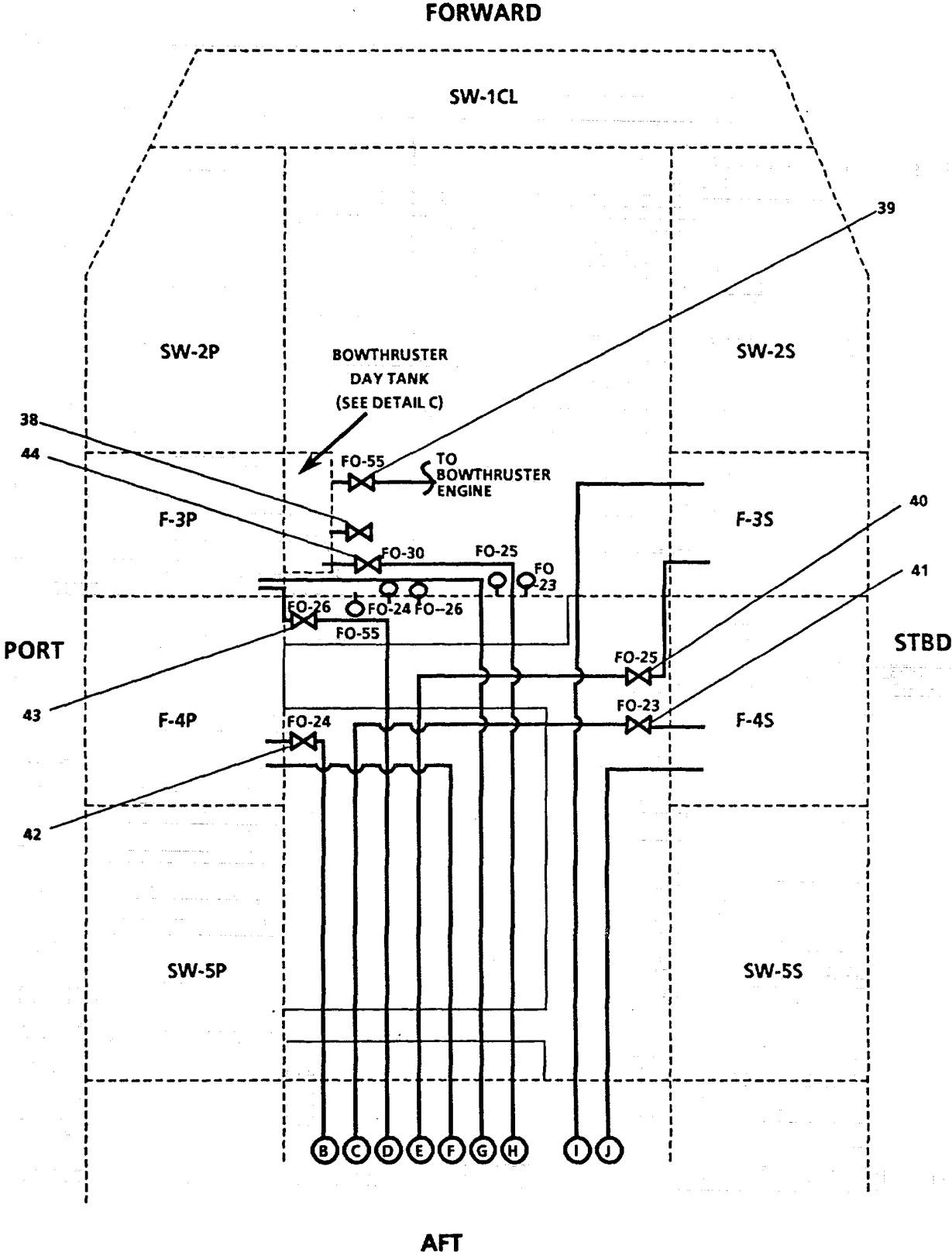

FIGURE 2-139. Fuel Oil Filter, Transfer and Supply Piping System (Sheet 2 of 6).

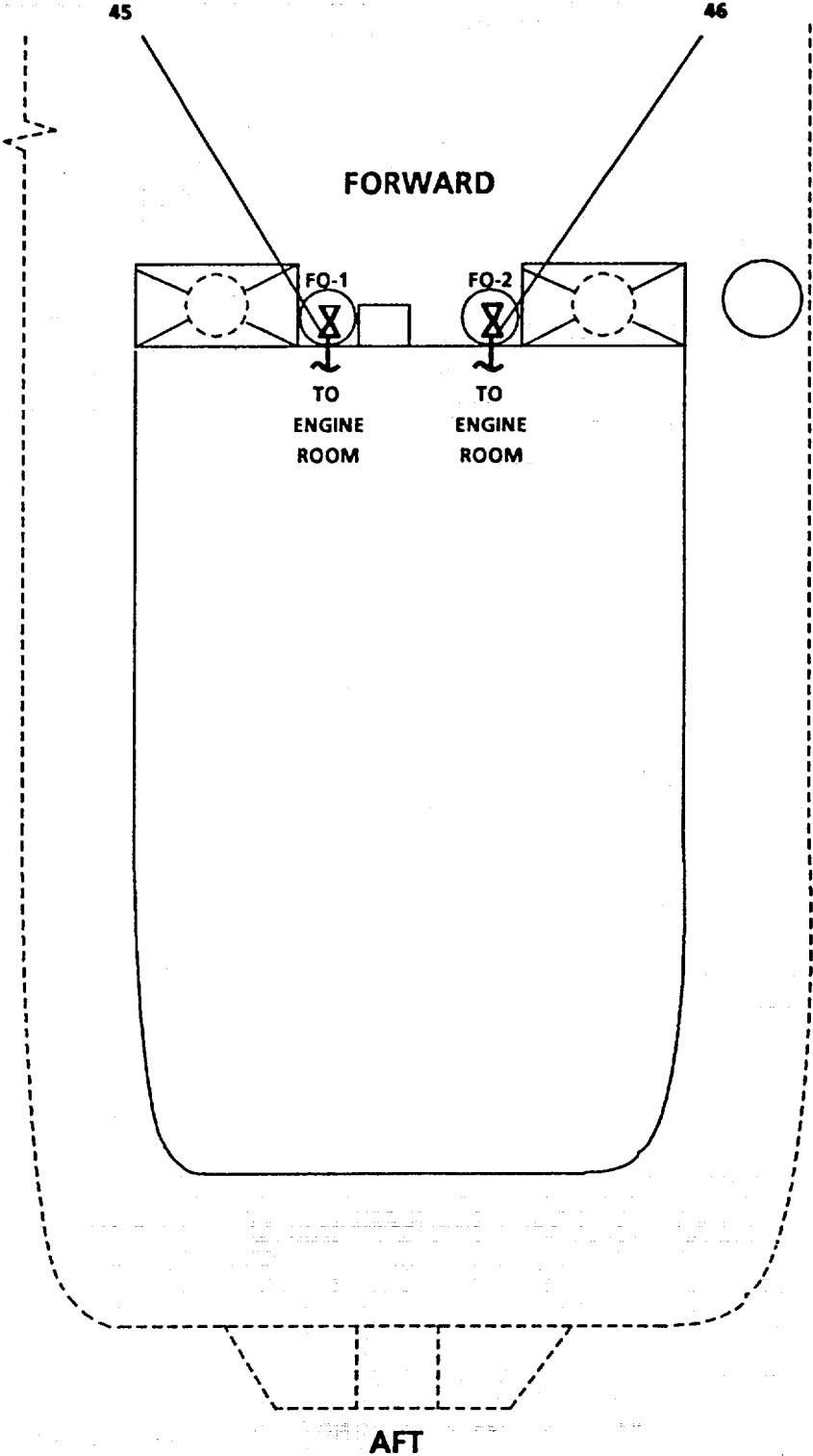
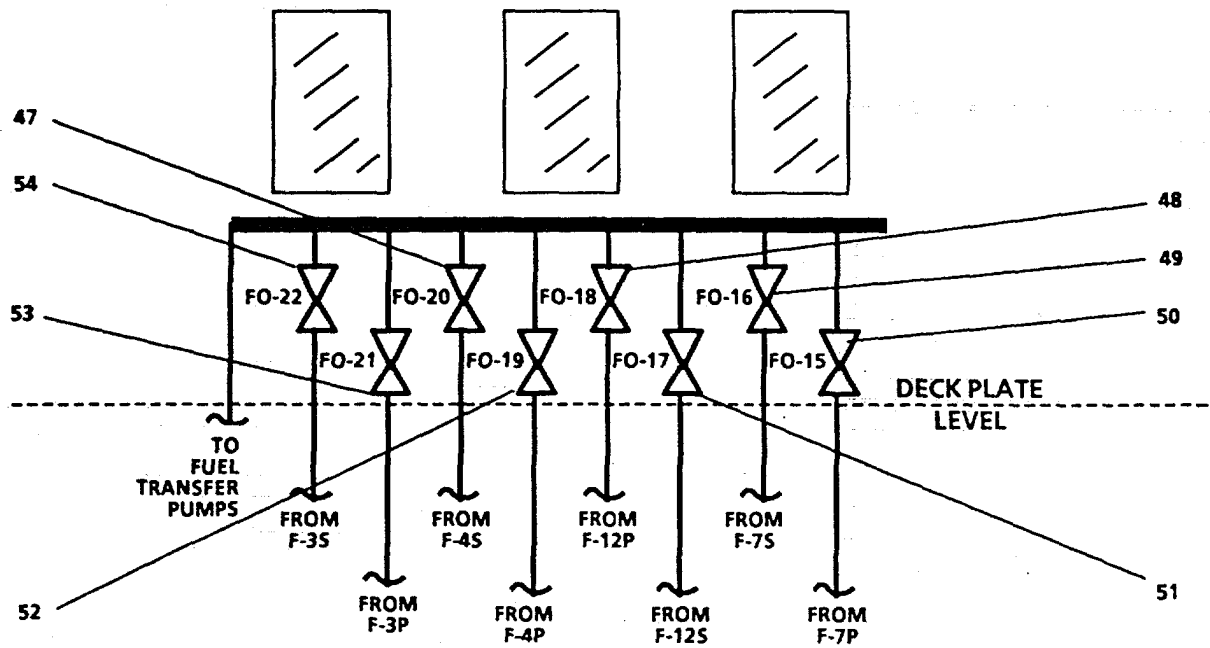

FIGURE 2-139. Fuel Oil Filter, Transfer and Supply Piping System (Sheet 3 of 6).

**DETAIL A**  
**PORT EXTERIOR BULKHEAD**  
**OF EOS (FORWARD)**



**DETAIL B**  
**FORWARD EXTERIOR BULKHEAD**  
**OF EOS (PORT)**

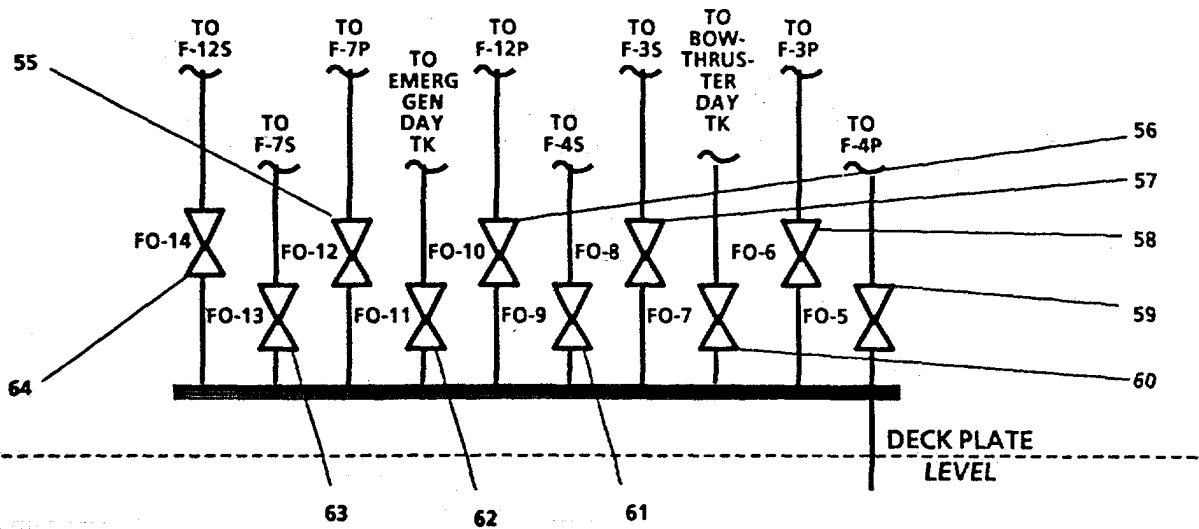

FIGURE 2-139. Fuel Oil Filter, Transfer and Supply Piping System (Sheet 4 of 6).

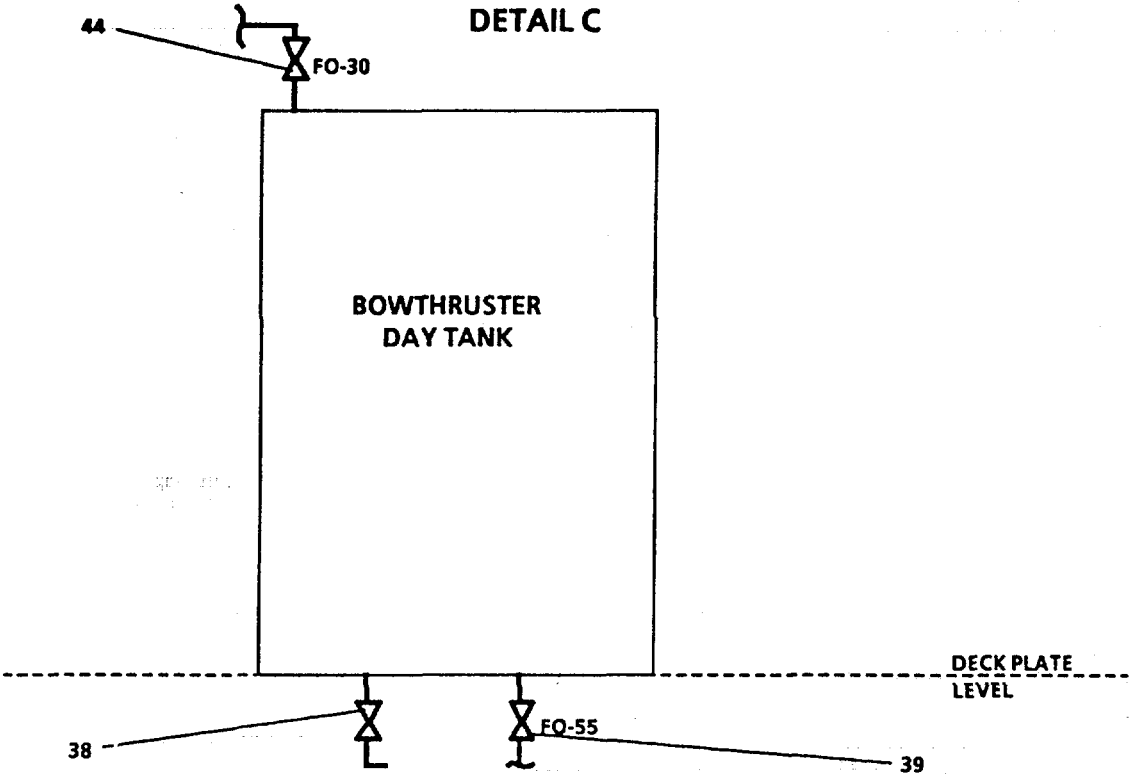

FIGURE 2-139. Fuel Oil Filter, Transfer and Supply Piping System (Sheet 5 of 6).

**LEGEND**

- |  |  |
|--|--|
| 1. FO-3, ISLN-FILL/DISCH STATIONS                    | 33. FO-46, HAND PUMP SUCT                  |
| 2. FO-4, SUPPY TO FO SUPPLY MANF                     | 34. FO-48, BY-PASS FILTER/SEPARATOR        |
| 3. FO-44, DISCH -NO. 2 XFR PUMP                      | 35. FO-43, SUCT-NO. 2 XFR PUMP             |
| 4. FO-53, DISCH- NO. 1 XFR PUMP                      | 36. NO. 2 XFR PUMP                         |
| 5. FO-52, SUCT-NO. 1 XFR PUMP                        | 37. NO. 1 XFR PUMP                         |
| 6. FO-54, PUMP DISCH PRESS GAGE                      | 38. BOW THRUSTER DAY TK DRAIN              |
| 7. FO-51, FILTER/SEPARATOR OUTLET                    | 39. FO-55, SUPPLY TO BOW THRUSTER ENGINE   |
| 8. FO-49, PUMP SUCT PRESS GAGE                       | 40. FO-25, SUCT FR TK F-3S                 |
| 9. FO-31, SUPPLY TO STBD SSDG                        | 41. FO-23, SUCT FR TK F-4S                 |
| 10. SSDG FUEL FILTERS                                | 42. FO-24, SUCT FR TK F-4P                 |
| 11. MN ENG FILTER DISCH VALVE                        | 43. FO-26, SUCT FR TK F-3P                 |
| 12. MN ENG FILTER                                    | 44. FO-30, SUPPLY TO BOW THRUSTER DAY TK   |
| 13. MN ENG FILTER INLET VALVE                        | 45. FO-1, FUEL OIL FILL/DISCH              |
| 14. FO-37, RETURN FR STBD MN ENG TO DAY TK F-12S     | 46. FO-2, FUEL OIL FILL/DISCH              |
| 15. FO-39, RETURN FR STBD SSDG TO DAY TK F-12S       | 47. FO-20, SUCT FR TK F-4S                 |
| 16. FO-35, SUCT FR DAY TK F-12S                      | 48. FO-18, SUCT FR TK F-12P                |
| 17. FO-33, DAY TK F-12S SUPPLY TO STBD MN ENG & SSDG | 49. FO-16, SUCT FR TK F-7S                 |
| 18. FO-41, DRAIN FR DAY TK F-12S                     | 50. FO-15, SUCT FR TK F-7P                 |
| 19. FO-27, SUCT FR TK F-7S                           | 51. FO-17, SUCT FR TK F-12S                |
| 20. FO-29, CROSS CONN - DAY TKS                      | 52. FO-19, SUCT FR TK F-4P                 |
| 21. FO-28, SUCT FR TK F-7P                           | 53. FO-21, SUCT FR TK F-3P                 |
| 22. FO-36, DAY TK F-12P SUPPLY TO PORT MN ENG & SSDG | 54. FO-22, SUCT FR TK F-3S                 |
| 23. FO-42, DRAIN FR DAY TK F-12P                     | 55. FO-12, SUPPLY TO TK F-7P               |
| 24. FO-34, SUCT FR DAY TK F-12P                      | 56. FO-10, SUPPLY TO DAY TK F-12P          |
| 25. FO-38, RETURN FR PORT MN ENG TO DAY TK F-12P     | 57. FO-8, SUPPLY TO TK F-3S                |
| 26. FO-40, RETURN FR PORT SSDG TO DAY TK F-12P       | 58. FO-6, SUPPLY TO TK F-3P                |
| 27. FO-32, SUPPLY TO PORT SSDG                       | 59. FO-5, SUPPLY TO TK F-4P                |
| 28. FO-50, DRAIN TO SLUDGE TK                        | 60. FO-7, SUPPLY TO TO BOW THRUSTER DAY TK |
| 29. FUEL FILTER/COALESCER                            | 61. FO-9, SUPPLY TO TK F-4S                |
| 30. FUEL TRANSFER HAND PUMP                          | 62. FO-11, SUPPY TO EMER GEN DAY TK        |
| 31. FO-47, FILTER/SEPARATOR INLET                    | 63. FO-13, SUPPY TO TK F-7S                |
| 32. FO-45, HAND PUMP DISCH                           | 64. FO-14, SUPPY TO TK F-12S               |

FIGURE 2-139. Fuel Oil Filter, Transfer and Supply Piping System (Sheet 6 of 6).



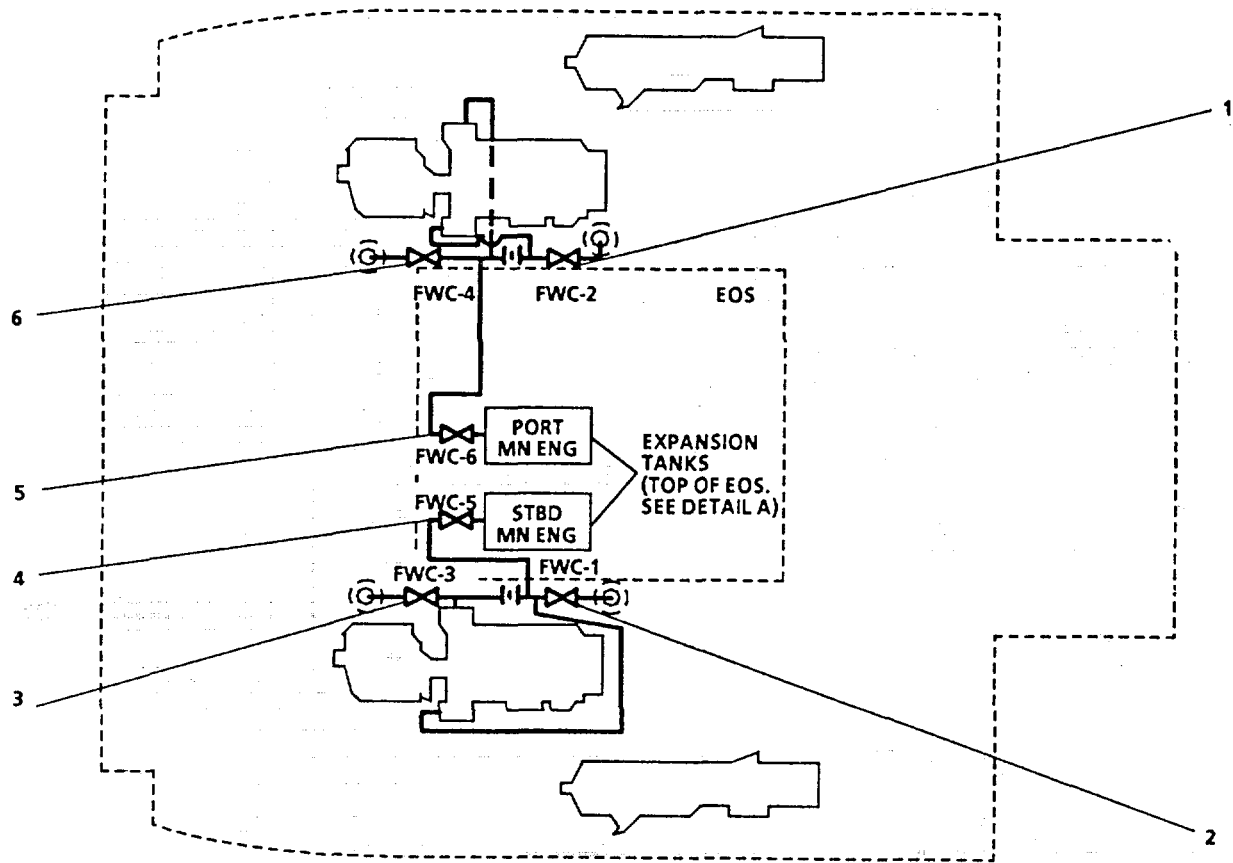

**LEGEND**

- |                              |                              |
|------------------------------|------------------------------|
| 1. FWC-2, SUPPLY-MN ENG PORT | 4. FWC-5, EXP TK-MN ENG STBD |
| 2. FWC-1, SUPPLY-MN ENG STBD | 5. FWC-6, EXP TK-MN ENG PORT |
| 3. FWC-3, RETURN-MN ENG STBD | 6. FWC-4, RETURN-MN ENG PORT |

FIGURE 2-140. Main Engine Fresh Water Cooling Piping System (Sheet 1 of 2).

DETAIL A

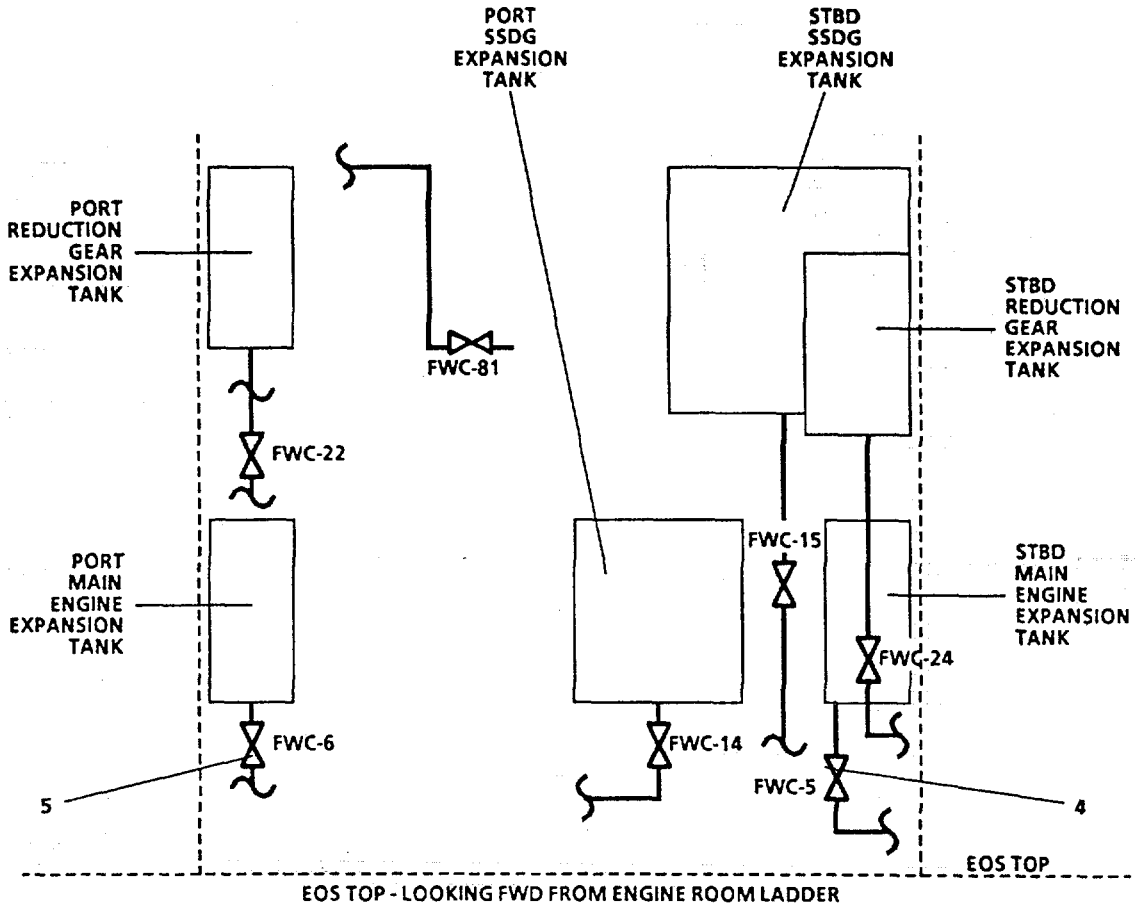

EOS TOP - LOOKING FWD FROM ENGINE ROOM LADDER

LEGEND

- 4. FWC-5, EXP TK-MN ENG STBD
- 5. FWC-6, EXP TK-MN ENG PORT

FIGURE 2-140. Main Engine Water Cooling Piping System (Sheet 2 of 2).

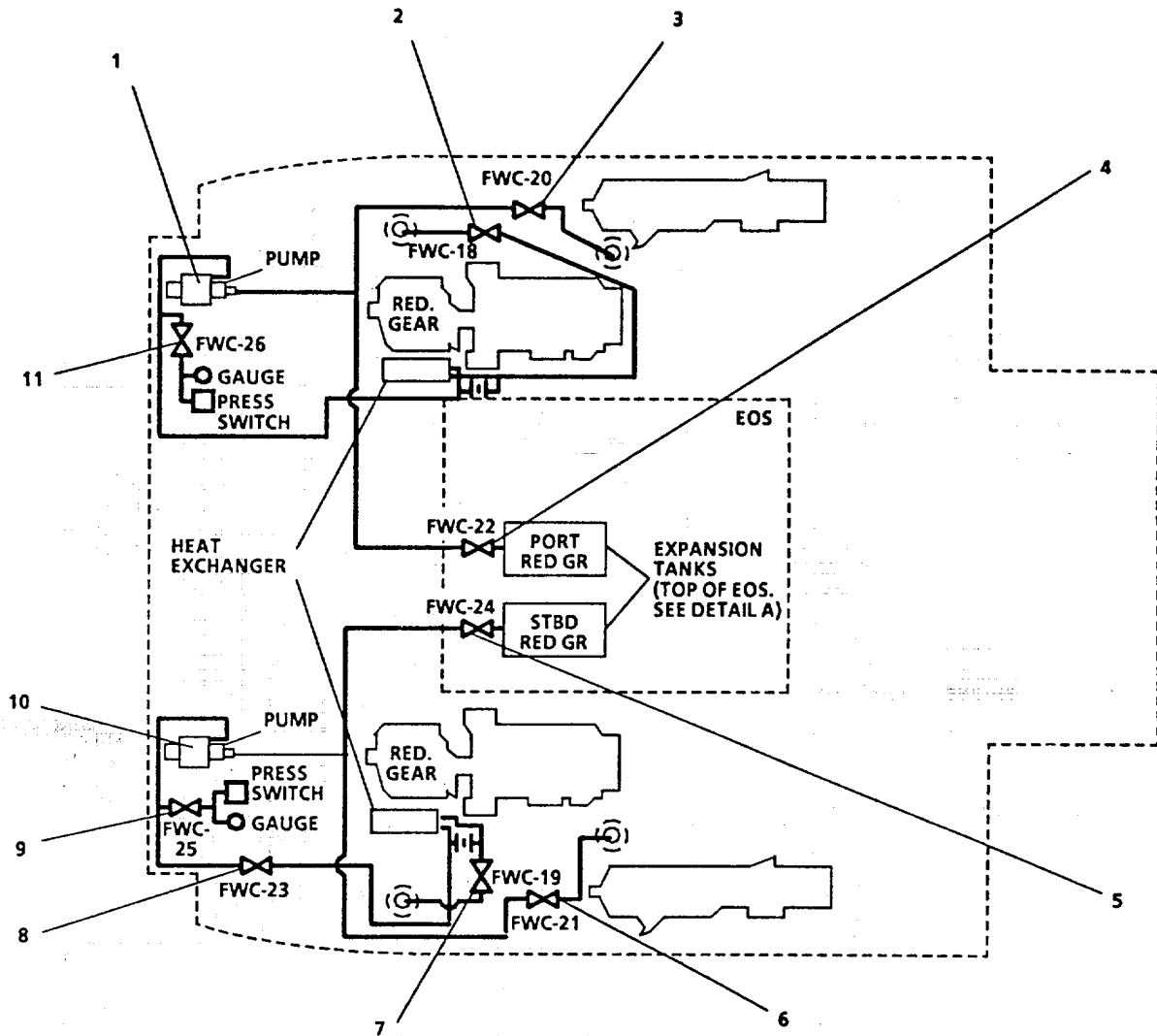

**LEGEND:**

- |  |  |
|--|--|
| 1. PORT RDCN GEAR COOLING PUMP               | 7. FWC-19, RETURN TO KEEL CLR RDCN GEAR STBD                         |
| 2. FWC-18, RETURN TO KEEL CLR RDCN GEAR PORT | 8. FWC-23, PUMP DISCH-RDCN GEAR STBD                                 |
| 3. FWC-20, PUMP SUCT-RDCN GEAR PORT          | 9. FWC-25, PRESS SW & PRESS GAGE PUMP DISCH-RDCN GEAR STBD           |
| 4. FWC-22, EXP TK-RDCN GEAR PORT             | 10. STBD RDCN GEAR COOLING PUMP                                      |
| 5. FWC-24, EXP TK-RDCN GEAR STBD             | 11. FWC-26, REDUCTION GEAR LUB OIL FRESH WATER COOLING PIPING SYSTEM |
| 6. FWC-21, PUMP SUCT-RDCN GEAR STBD          |  |

FIGURE 2-141. Reduction Gear Lube Oil Fresh Water Cooling Piping System (Sheet 1 of 2).

DETAIL A

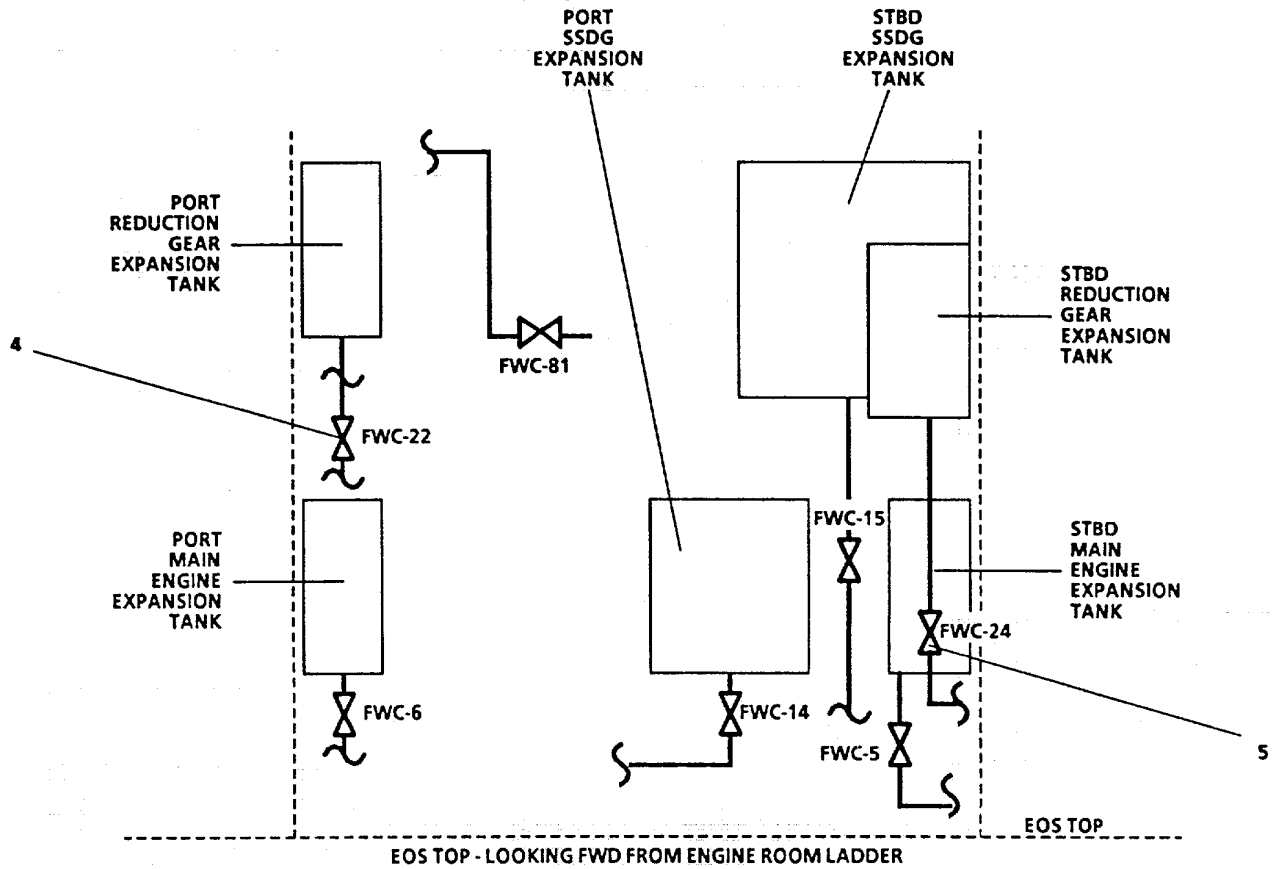

LEGEND:

- |  |  |
|--|--|
| 1. PORT RDCN GEAR COOLING PUMP               | 7. FWC-19, RETURN TO KEEL CLR RDCN GEAR STBD               |
| 2. FWC-18, RETURN TO KEEL CLR RDCN GEAR PORT | 8. FWC-23, PUMP DISCH-RDCN GEAR STBD                       |
| 3. FWC-20, PUMP SUCT-RDCN GEAR PORT          | 9. FWC-25, PRESS SW & PRESS GAGE PUMP DISCH-RDCN GEAR STBD |
| 4. FWC-22, EXP TK-RDCN GEAR PORT             | 10. STBD RDCN GEAR COOLING PUMP                            |
| 5. FWC-24, EXP TK-RDCN GEAR STBD             | 11. FWC-26   |
| 6. FWC-21, PUMP SUCT-RDCN GEAR STBD          |  |

FIGURE 2-141. Reduction Gear Lube Oil Fresh Water Cooling Piping System (Sheet 2 of 2).

- (a) Open FWC-22, EXP TK-RDCN GEAR PORT (4).
  - (b) Open FWC-26, PRESS SW & PRESS GAUGE PUMP DISCH-RDCN GEAR PORT (11).
  - (c) Open FWC-20, PUMP SUCT-RDCN GEAR PORT (3).
  - (d) Open FWC-18, RETURN TO KEEL CLR RDCN GEAR PORT (2).
  - (e) On Auxiliary Machinery Motor Control Center (FIGURE 2-142), set P205-8 REDUCTION GEAR COOLING WATER PUMP NO. 2 circuit breaker (1) to on position.
  - (f) Press START (1, FIGURE 2-143) pushbutton on TYPE-I Motor Switch near reduction gear cooling water pump No. 2.
- (4) Align Compressed Air Piping System (FIGURE 2-135) to port main engine as follows:
- (a) Open LPA-11, SUPPLY TO MN ENG-PORT (29).
  - (b) Open LPA-16, SUPPLY TO MN ENG-PORT (10).

**NOTE**

Engine manufacturer recommends the engine be prelubed only if it has been shut down for 2 weeks or more. To prelube the engine, the following procedure is used:

- (5) Prelube Port Main Engine (FIGURE 2-136) as follows:
- (a) Open LO-13, PRE-LUBE PUMP SUCT (25).
  - (b) Open LO-12, PRE-LUBE PUMP DISCH (26).
  - (c) Open LO-39, PRESSURE GAGE ISLN (24).
  - (d) Open LO-14, PRE-LUBE/PURIFIER SUCT (14).
  - (e) Open LO-18, PUMP SUCT-PORT ENG (12).
  - (f) Open LO-22, PRE-LUBE RETURN-PORT ENG (5).
  - (g) At Auxiliary Machinery Motor Control Center (FIGURE 2-142), set P205-9 PRE-LUBE PUMP circuit breaker (3) to ON position, press START (1, FIGURE 2-143) pushbutton on TYPE-1 Motor Switch near prelube pump.
  - (h) In Engine Room Operating Station on Engine Room Console Panel (FIGURE 2-137) press +PAGE pushbutton (1) until main engine oil pressure (PAGE 2) appears on MCHRY PLANT MONITOR. When the display indicates 3 to 4 psi, press STOP pushbutton (2) on the Auxiliary Machinery Motor Control Center (FIGURE 2-142) or press STOP (2, FIGURE 2-143) on TYPE-I Motor Switch near pre-lube pump.

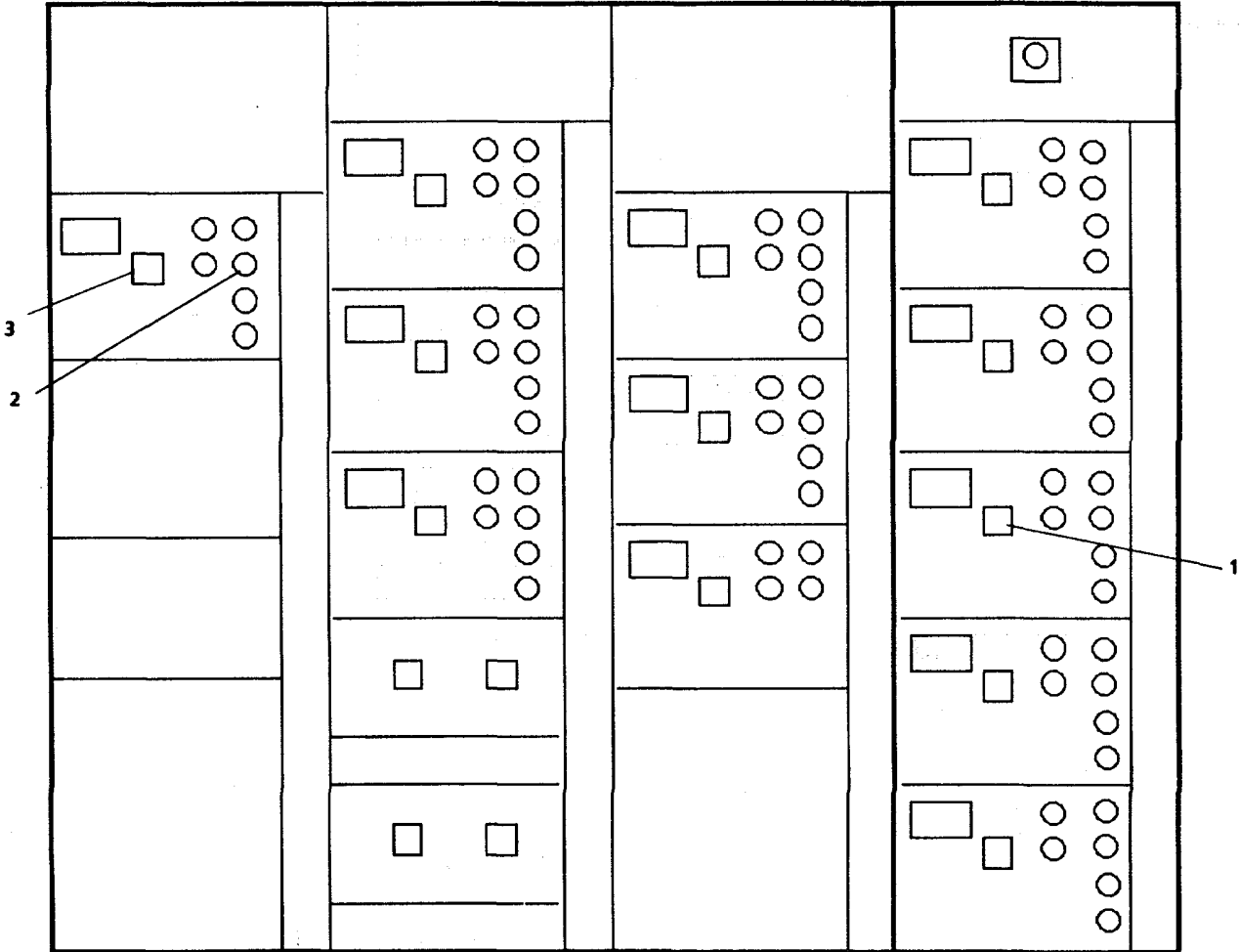

**LEGEND**

- 1. REDUCTION GEAR COOLING WATER PUMP NO. 1 (P205-7)
- 2. STOP
- 3. PRE-LUBE PUMP

FIGURE 2-142. Auxiliary Machinery Motor Control Center.

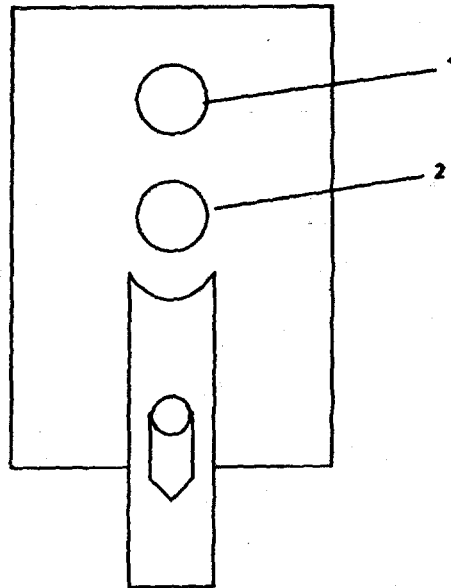

**LEGEND**

- 1. START**  
**2. STOP**

FIGURE 2-143. TYPE-I Motor Switch.

- (i) Close all valves in Lube Oil Purification and Transfer Piping System (FIGURE 2-136).
- (6) Start Port Main Engine.
  - (a) At Main Engine Control Panel (FIGURE 2-138), START AIR PRESSURE gauge (3) needle indicates 125 psi.
  - (b) Set REMOTE START CUTOFF SWITCH (6) for local operation.
  - (c) Set POWER SWITCH EMERGENCY STOP (5) switch to UP position.
  - (d) Press PUSH TO START ENGINE START (4) pushbutton.

**NOTE**

Engine should start within 10 seconds.

- (e) Release PUSH TO START ENGINE START (4) pushbutton.
- (f) Monitor ENGINE OIL PRESSURE gauge (1) (20 to 70 psi), ENGINE OIL TEMP gauge (8) (175°F to 195°F), and ENGINE WATER TEMP gauge (8) (160°F to 203°F).

## 2-13. Steering System

**WARNING**

- **Before applying power to steering hydraulic pump motors, ensure rudders are clear aft of vessel. Secure permission from proper authority to move rudders.**
- **Station a crew member at pumpset motor control panel to press STOP pushbuttons in case of faulty or improper performance of either pumpset during preoperational checks of steering system.**

a. Steering System Preparation Procedures. Align Steering Gear Hydraulic Piping System (FIGURE 2-149.1) as follows:

- (1) Close all valves in the steering gear hydraulic steering gear piping system.
- (2) Open valve B, LOCK VLV-PORT STRG RAM.
- (3) Open valve D, LOCK VLV-PORT STRG RAM.
- (4) Open valve C, LOCK VLV-STBD STRG RAM.
- (5) Open valve A, LOCK VLV-STBD STRG RAM.
- (6) Open valve G, UNIT No. 1 ISLN.
- (7) Open valve H, UNIT No. 2 ISLN.
- (8) Open valve E, UNIT No. 1 ISLN.
- (9) Open valve F, UNIT No. 2 ISLN.
- (10) Open valve I, Pump Unit No. 1.
- (11) Open valve J, Pump Unit No. 1.
- (12) Open valve K, Pump Unit No. 2.
- (13) Open valve L, Pump Unit No. 2.
- (14) Ensure that the STEERING CONTROL PANEL (FIGURE 2-149.2), located in the pilot house, "MODE SELECT SWITCH" (3) is in the "OFF" position.



- (15) Ensure that the STEERING ROOM LOCAL CONTROL UNIT (FIGURE 2-149.3) , located in the steering compartment, "MODE SELECT SWITCH" (1) is in the "REMOTE" position on each panel.
- (16) Ensure that the STEERING GEAR MOTOR CONTROLLER PANEL (FIGURE 2-149.4)), located in the steering compartment, "CIRCUIT BREAKER SWITCH" (1) in the "ON" position on each panel.
- (17) Ensure that the STEERING GEAR MOTOR CONTROLLER PANEL (FIGURE 2-149.4) , "LOCAL/OFF/REMOTE SWITCH" (3) is in the "REMOTE" position on each panel.
- (18) Ensure that the 24 VOLT DISTRIBUTION PANEL (FIGURE 2-149.5) , located in the communications area, "STEERING CONTROL CONSOLE SWITCH" (2) is in the "ON" position.

b. Steering Gear System Operation

- (1) On the STEERING GEAR CONTROL PANEL (FIGURE 2-149.2) press the "LAMP TEST PUSHBUTTON" (4) and ensure that all lamps light.
- (2) On the STEERING GEAR CONTROL PANEL (FIGURE 2-149.2) adjust the "DIMMER CONTROL SWITCH" (7) for best reading level.
- (3) On the STEERING GEAR CONTROL PANEL (FIGURE 2-149.2) set the "PUMP SELECTOR SWITCH" (2) TO THE "pump No. 1" position.

**NOTE**

**The pump No. 1 run green power available indicator should light, if indicator does not light, shutdown and notify unit maintenance.**

- (4) On the STEERING GEAR CONTROL PANEL (FIGURE 2-149.2) set the "MODE SELECTOR SWITCH" to the "NON-FOLLOW-UP" position.

**WARNING**

**Do not operate rudders without obtaining proper authority. Ensure that all personnel and equipment are clear of rudder areas and other moving parts.**

- (5) Observe rudder operation as follows:

- (a) On the STEERING GEAR CONTROL PANEL (FIGURE 2-149.2) press the "port non- follow-up controller pushbutton" (6), rudder will move to port as shown on the RUDDER ANGLE INDICATOR.
- (b) On the STEERING GEAR CONTROL PANEL (FIGURE 2-149.2) press the "STBD NON- FOLLOW-UP CONTROLLER PUSHBUTTON" (5), rudder will move to starboard as shown on the RUDDER ANGLE INDICATOR.
- (c) On the STEERING GEAR CONTROL PANEL (FIGURE 2-149.2) set the "MODE SELECT SWITCH" (3) to the "FOLLOW UP" position.
- (d) Turn the helm counter-clockwise and the rudder will move to port as shown on the RUDDER ANGLE INDICATOR, and on the "RUDDER ORDER INDICATOR" (2).
- (e) Turn the helm clockwise and the rudder will move to starboard as shown on the RUDDER ANGLE INDICATOR, and on the "RUDDER ORDER INDICATOR" (2).
- (f) Direct the operator in the steering compartment to set the STEERING GEAR LOCAL CONTROL UNIT (FIGURE 2-149.3) "MODE SELECT SWITCH" (1) to the "LOCAL" position, and then perform the following:
  - 1) Set the "NON-FOLLOW-UP TOGGLE SWITCH" (2) to the "PORT" position, the rudder will move to port as indicated on the "RUDDER ANGLE INDICATOR" (4).
  - 2) Set the "NON-FOLLOW-UP TOGGLE SWITCH" (2) to the "STBD" position, the rudder will move to starboard as indicated on the "RUDDER ANGLE INDICATOR" (4).
  - 3) Set the "MODE SELECT SWITCH" (1) to the "REMOTE" position.
- (g) On the STEERING GEAR CONTROL PANEL (FIGURE 2-149.2) set the 'PUMP SELECTOR SWITCH" (1) TO THE "PUMP No. 2" position.

**NOTE**

**The pump No. 2 run green power available indicator should light, if indicator does not light, shutdown and notify unit maintenance.**

- (h) Repeat system check for pump No. 2 by repeating steps b.4 through b.5.f.

c. Auto Pilot Operation

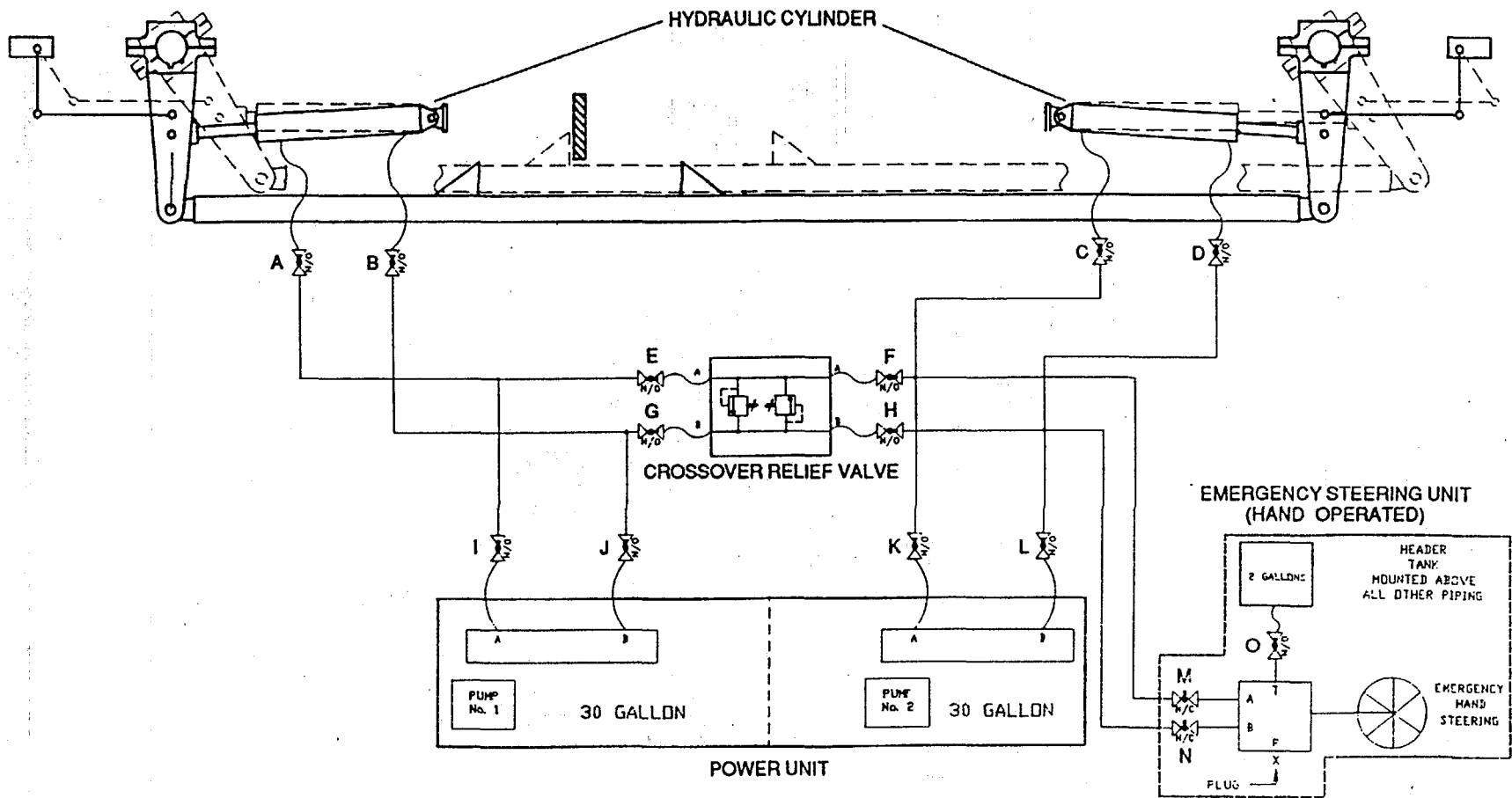

FIGURE 2-149.1. Steering Gear Hydraulic Piping System

Change 2 2-427



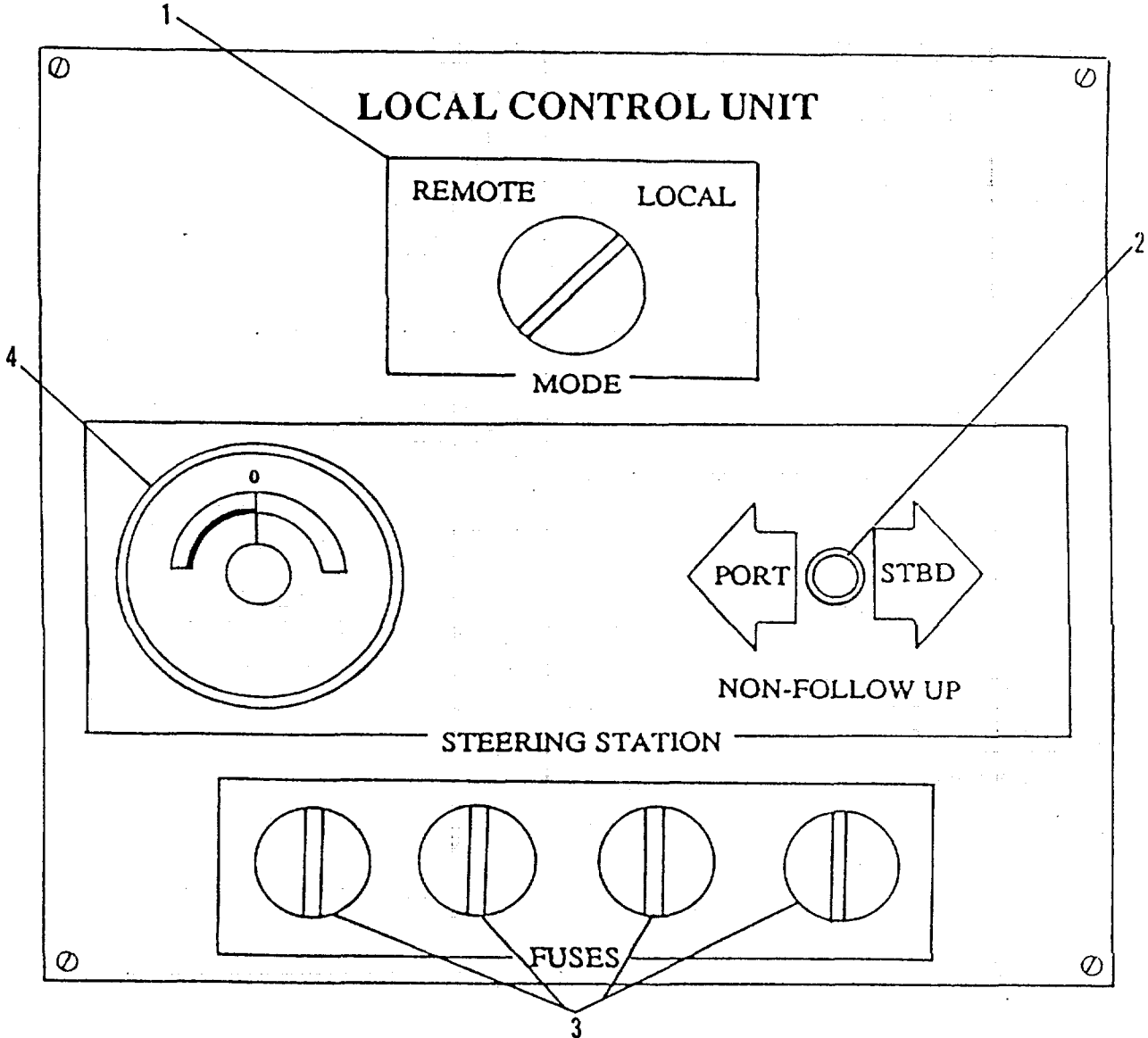

FIGURE 2-149.3. Steering Gear Local Control Unit

Change 2 2-429

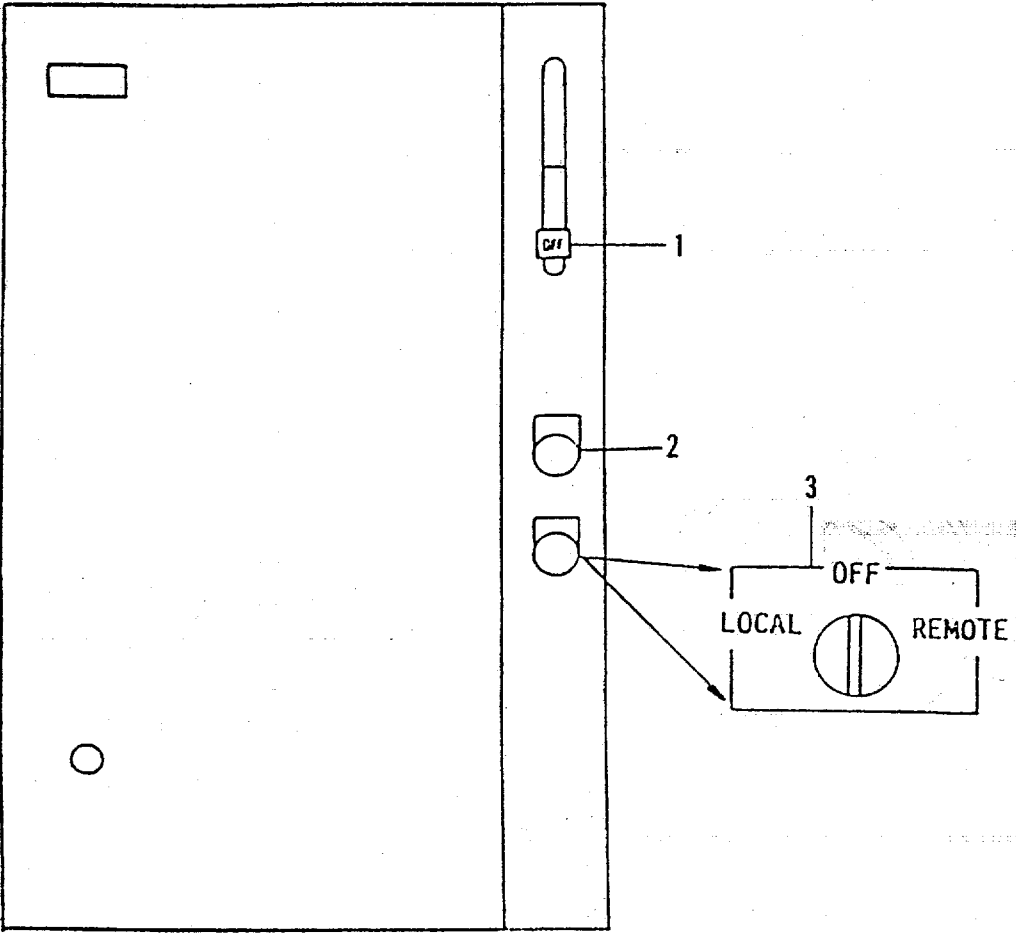

FIGURE 2-149.4. Steering Gear Motor Controller

Change 2 2-430

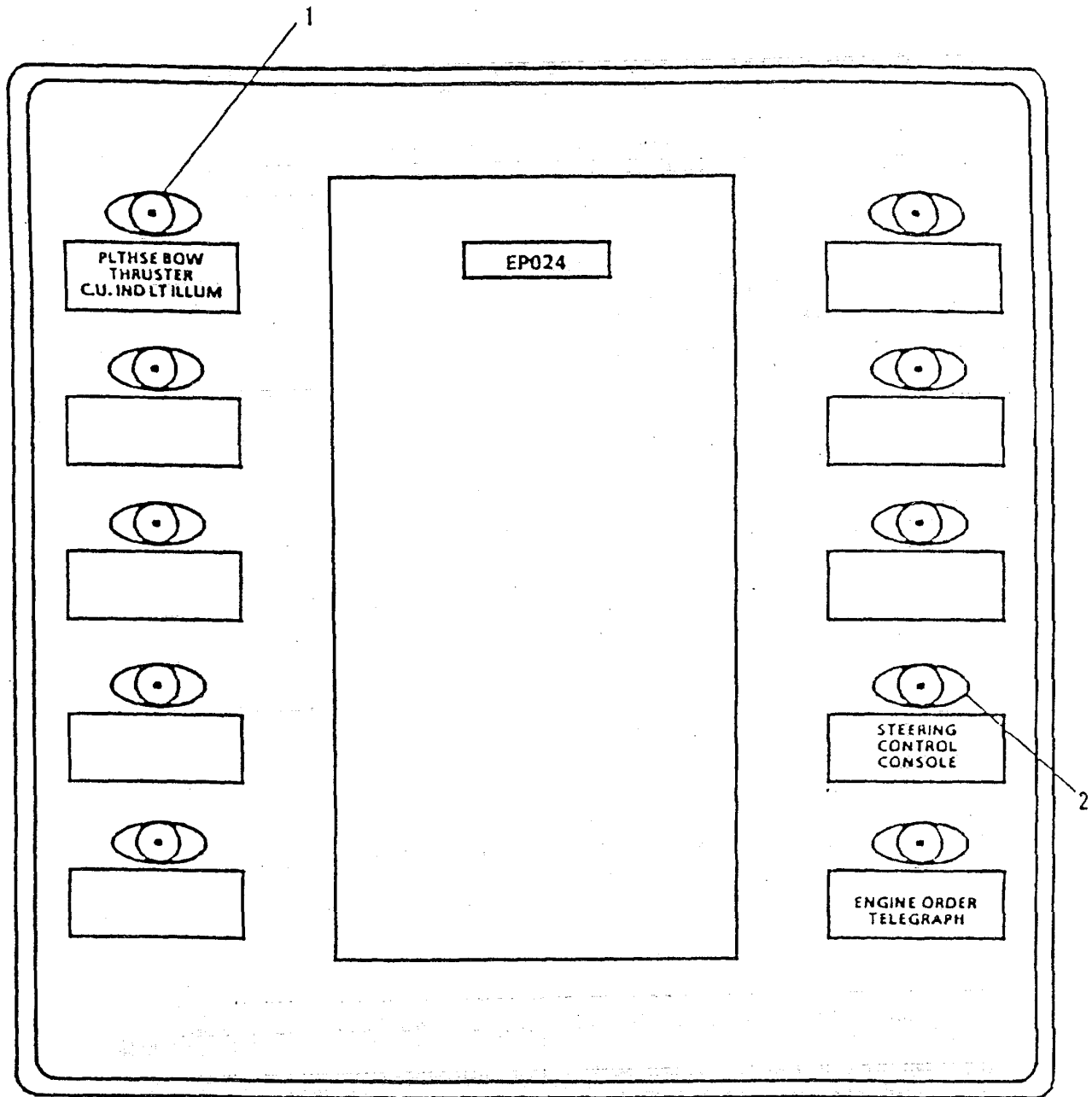

FIGURE 2-149.5. Power Panel Box

Change 2 2-431

- (1) On the STEERING GEAR CONTROL PANEL (FIGURE 2-149.2) set the "MODE SELECT SWITCH" (3) "AUTO PILOT" position.
- (2) On the STEERING GEAR AUTO PILOT CONTROL (FIGURE 2-149.6) adjust the "DIMMER CONTROL" (7) for best reading level.
- (3) Change course by adjusting the "HEADING CHANGER KNOB" (1) until the desired course appears on the "BULB" (2).
- (4) Set the "WEATHER KNOB" (5). A maximum setting (counterclockwise) is best for good sea conditions and provides maximum course holding. The maximum setting (clockwise) is best for rough sea conditions.
- (5) Set the "RUDDER MULTIPLIER KNOB" (4). This adjustment determines how much the heading error signal is amplified before it is compared to the actual rudder position feedback signal.
- (6) Set the "RUDDER LIMIT KNOB" (3). This adjustment limits the maximum rudder travel that may be commanded by the auto pilot amplifier.
- (7) Adjust the "HELM TOGGLE SWITCH" (6). The "PERMANENT HELM" adjustment allows the auto pilot amplifier to bring the vessel to the exact desired heading in the presence of a steady wind or a steady running sea, which would tend to push the vessel continuously off course. The "PERMANENT HELM TOGGLE SWITCH" (6) should remain in the "OFF" position during calm winds and seas.
- (8) As the craft comes to new heading, verify that the "BULB" (2) indicates new heading.

**NOTE**

**During normal steering gear operation the port and starboard steering gear ram lock valves will remain open at all times.**

d. Steering System Shutdown

- (1) On the STEERING GEAR CONTROL PANEL (FIGURE 2-149.2) set the "MODE SELECTOR SWITCH" (3) to the "OFF" position.
- (2) On the STEERING GEAR MOTOR CONTROLLER (FIGURE 2-149.4) set the "CIRCUIT BREAKER LEVER" (1) to the "OFF" position on each motor controller.
- (3) On the 24 VOLT DISTRIBUTION PANEL J(FIGURE 2-149.5) set the "STEERING CONTROL CONSOLE SWITCH" (2) to the "OFF" position.



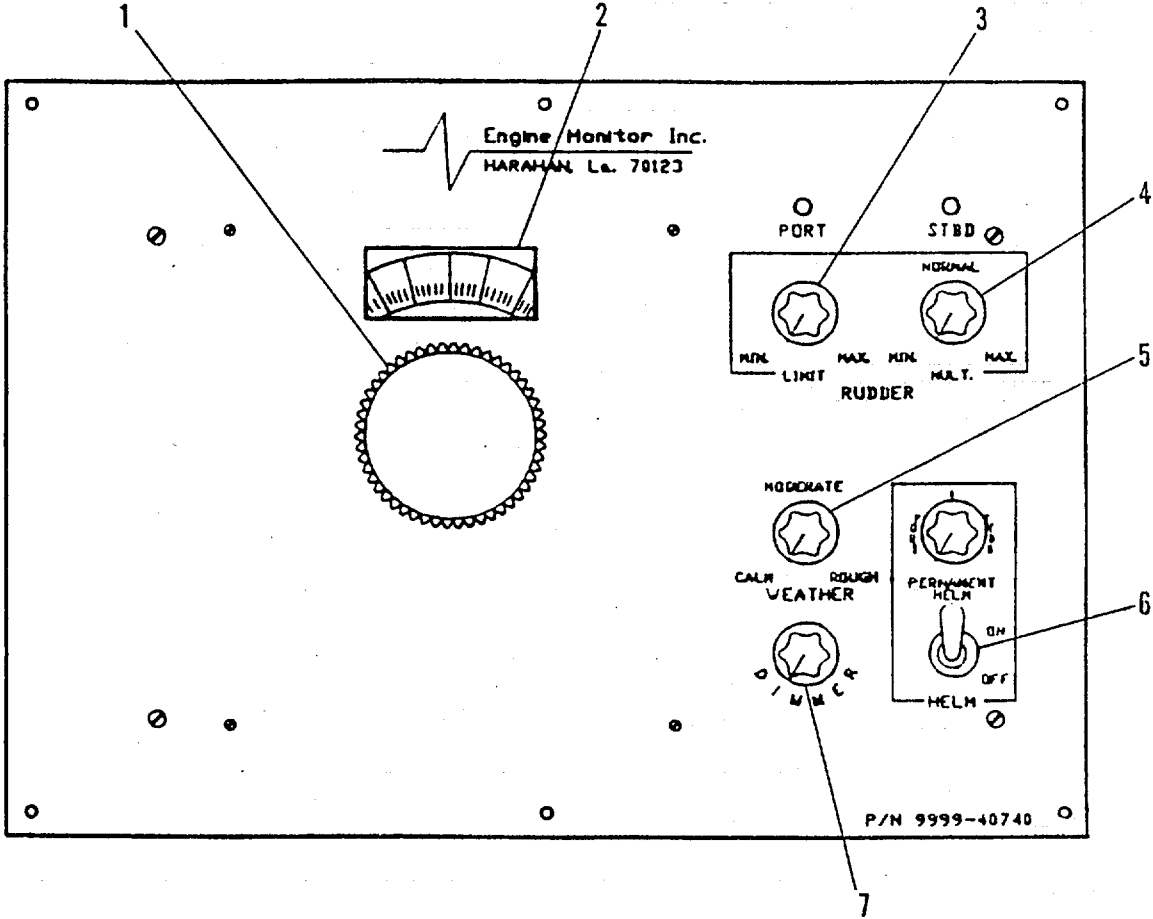

FIGURE 2-149.6. Steering Gear Autopilot Control

Change 2 2-432.1/(2-432.2 blank)

- (4) Close valve I, Pump Unit No. 1.
- (5) Close valve J, Pump Unit No. 1.
- (6) Close valve K, Pump Unit No. 2.
- (7) Close Valve L, Pump Unit No. 2.

**2-14. Bowthruster System.**

a. Bowthruster Diesel Engine.

- (1) Align Bowthruster Fuel Oil Day Tank (FIGURE 2-150) by opening FO-55, DAY TK SUPPLY TO BOWTHRUSTER ENG (1).
- (2) Align Bowthruster Sea Water Cooling Piping System to the Bowthruster Diesel Engine as follows:
  - (a) Open SW-29, SEA CHEST SUCT (2, FIGURE 2-151).
  - (b) Open SW-34 VENT, ISOLATION (3)
  - (c) Open SW-33 VENT (7)
  - (d) Open SW- 30, ENG EXHAUST CUTOUT (1) (located on main deck underneath port forecastle ladder).
  - (e) At the Bowthruster Engine Control Panel (FIGURE 2-152), set STARTER CUTOUT SWITCH (2) to up position. Set START SWITCH (1) to down position.
  - (f) Ensure block heater is operating.
- (3) Turn Bowthruster Steering Pump Motor Controller (FIGURE 2-153) circuit breaker (1) to ON position.
- (4) Ensure battery charger is ON.

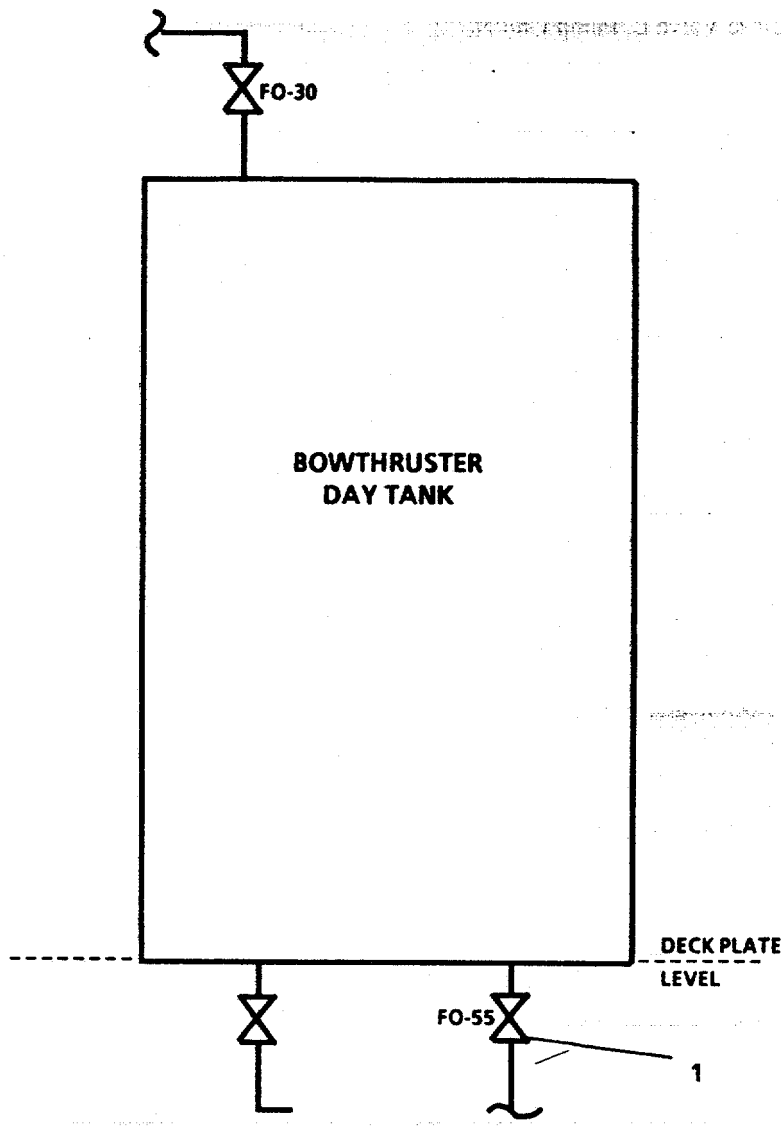

1. FO-55, DAY TK SUPPLY TO BOWTHRUSTER ENG

FIGURE 2-150. Bowthruster Fuel Oil Day Tank.

Change 1 2-434

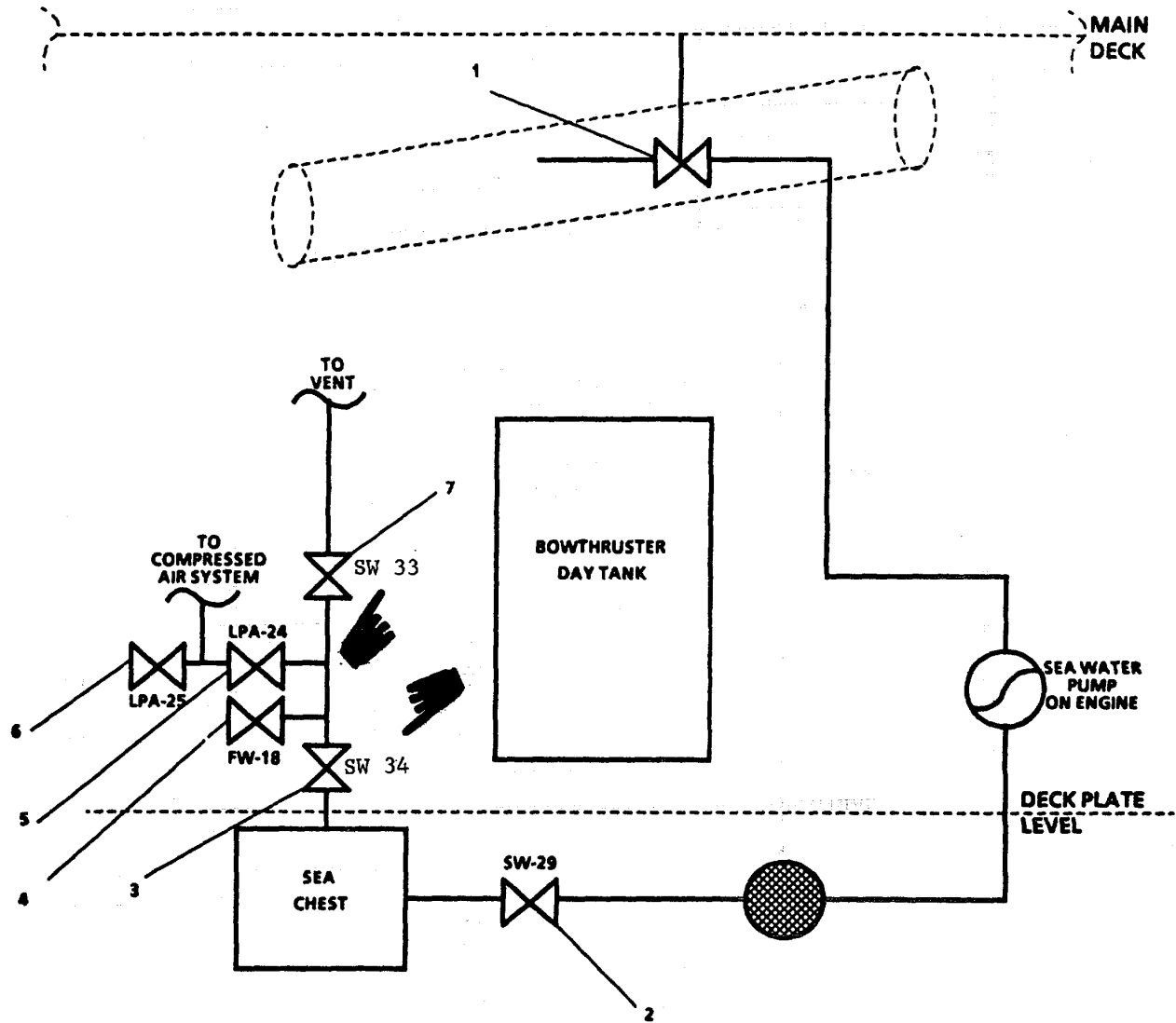

**LEGEND**

- |  |  |
|--|--|
| <ul style="list-style-type: none"> <li>1. SW-30, ENGINE EXHAUST CUTOUT (CONTROLLED FROM MAIN DECK, UNDER PORT FORECASTLE LADDER).</li> <li>2. SW-29, SEA CHEST SUCT</li> <li>3. SEA CHEST VENT ISOLATION</li> <li>4. FW-18, SEA CHEST - HOT FW CONN</li> </ul> | <ul style="list-style-type: none"> <li>5. LPA-24, SEA CHEST BLWDN</li> <li>6. LPA-25, SUPPLY TO SVCE SIR</li> <li>7. SEA CHEST VENT</li> </ul> |
|--|--|

FIGURE 2-151. Bowthruster Sea Water Cooling Piping System.

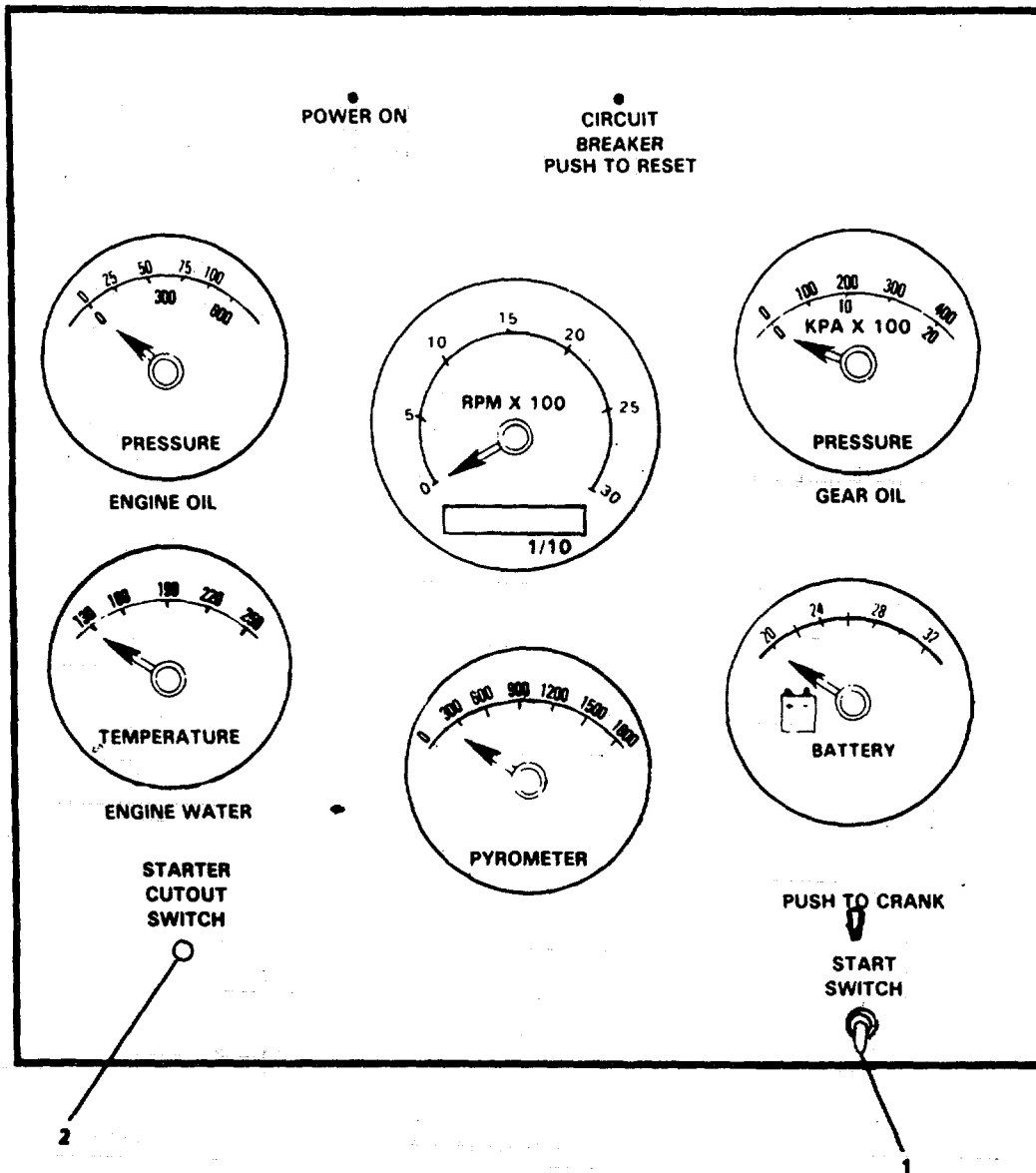

**LEGEND**

- 1. START SWITCH
- 2. STARTER CUTOUT SWITCH

FIGURE 2-152. Bowthrustrer Engine Control Panel.

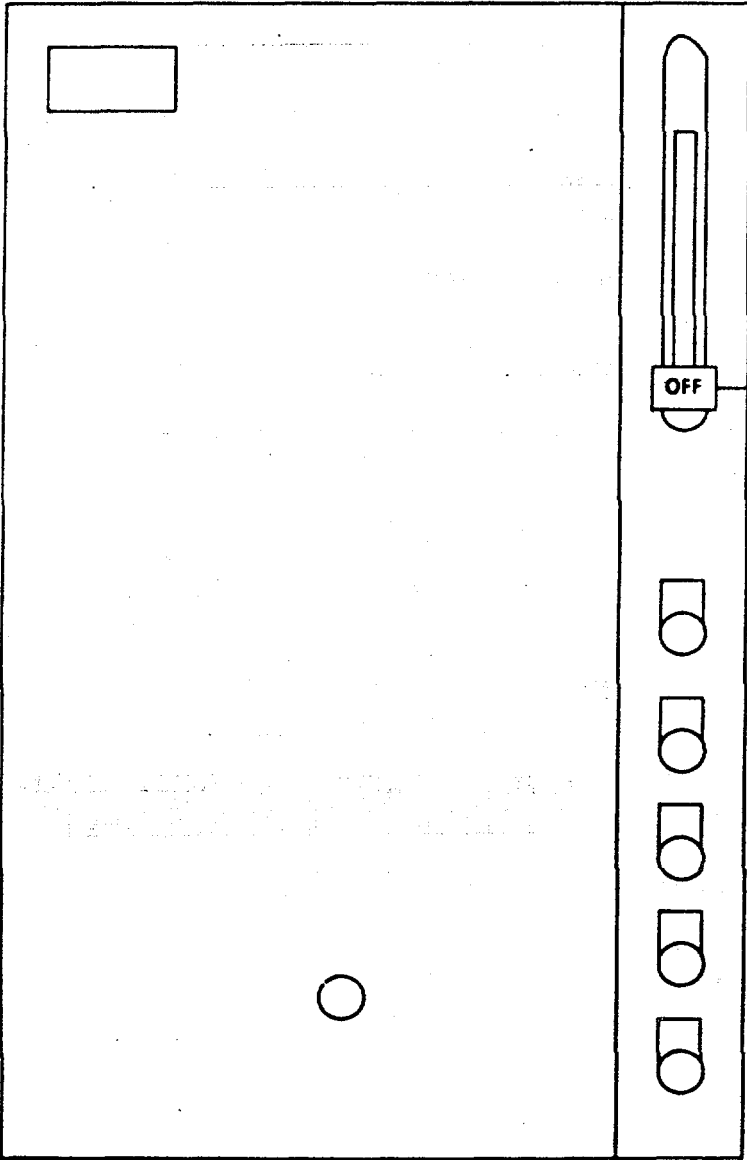

**LEGEND**  
1. **CIRCUIT BREAKER HANDLE**

FIGURE 2-153. Bowthruster Steering Pump Motor Controller.

- (5) Turn-on 24V System, (FIGURE 2-148), by setting PLTHSE BOW THRUSTER C.U. IND LT. ILLUM (1) to ON position. (This panel is located in the Communications Area.)

**NOTE**

All diesel engines except main engines on the LCU have an Automatic Low Oil Pressure Shutdown System. This system will activate at a low oil pressure condition and shut engine down.

b. Waterjet Operation.

- (1) On Engine Room Console (FIGURE 2-154), set CONTROL AIR SELECTOR (1) to bridge position.
- (2) At Pilothouse Console (FIGURE 2-155), set CONTROL AIR VALVE (3) to UP position.
- (3) On Bowthruster Waterjet Control Panel (FIGURE 2-156) insert key into SCHOTTEL unit ON slot (1) and turn clockwise to ON position.
- (4) Set Hydraulic pump ON switch (4) to ON position.
- (5) Rotate STEERING port-starboard (3) joystick, in starboard direction for short pulse. Check THRUST DIRECTION INDICATOR (2) moves to starboard.
- (6) Rotate STEERING port-starboard (3) joystick, in port direction for short pulse. Check THRUST DIRECTION INDICATOR (2) moves to port.

**CAUTION**

If engine fails to start within 30 seconds, release CRANK pushbutton. Wait 2 minutes to allow starter motor to cool before using it again.

- (7) Press bowthruster start button (1, FIGURE 2-157) and check BOWTHRUSTER TACHOMETER (2, FIGURE 2-155) for RPM. Tachometer should read 650 rpm.
- (8) Go to page 6 on the MACHINERY PLANT MONITOR (4, FIGURE 2-155); check oil pressure (4 psi) and water temp (1100F Min.).
- (9) Using STEERING CONTROL JOYSTICK(3, FIGURE 2-156), set THRUST DIRECTION INDICATOR (2) to desired direction.
- (10) Engage waterjet clutch by pressing BOWTHRUSTER/FIRE PUMP THROTTLE/CLUTCH (1, FIGURE 2-155), to right, to first indented position. To increase engine speed, continue to press BOWTHRUSTER/ FIRE PUMP THROTTLE/CLUTCH lever (1), to right until desired engine speed is reached.

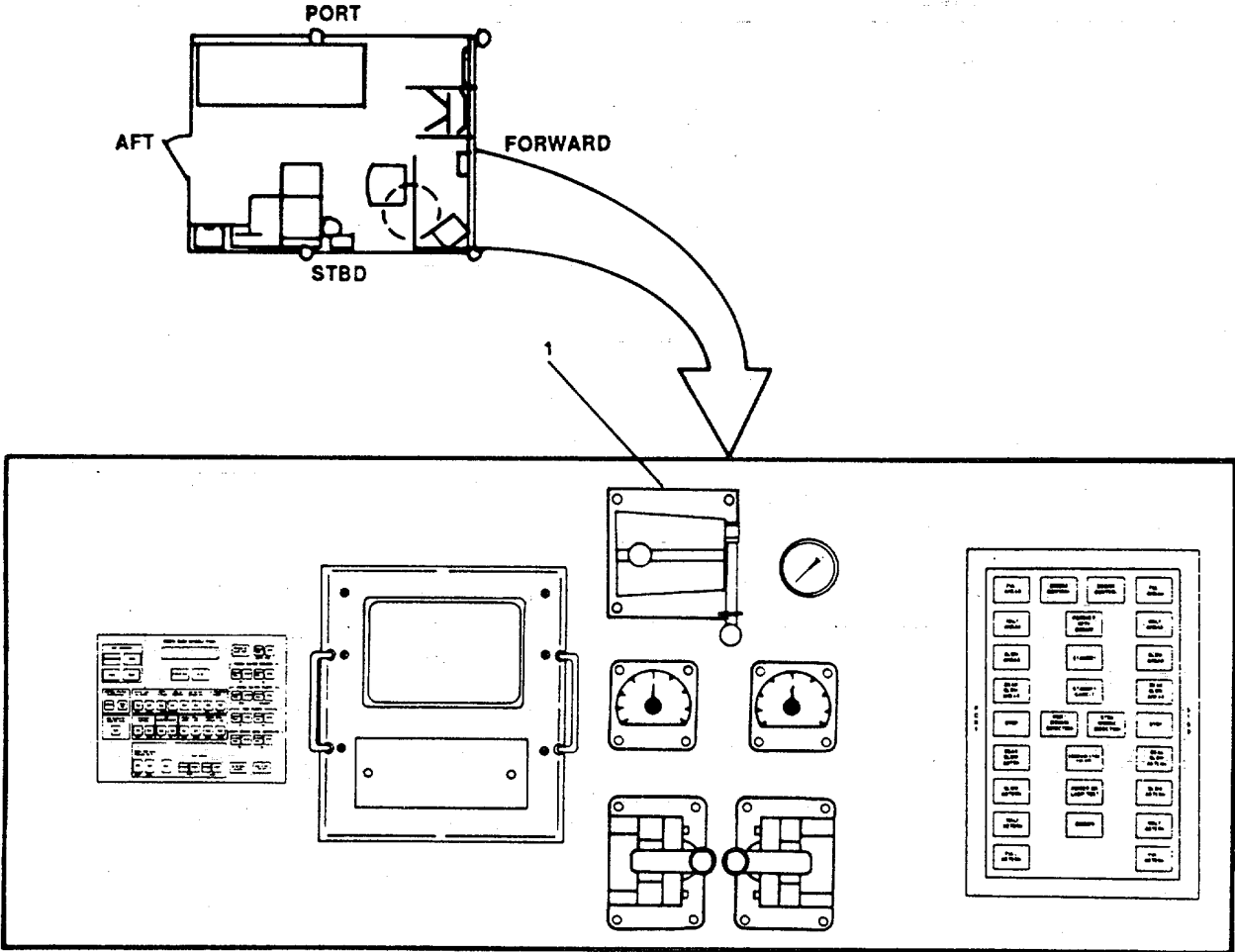

**LEGEND**  
1. CONTROL AIR SELECTOR

FIGURE 2-154. Engine Room Console.



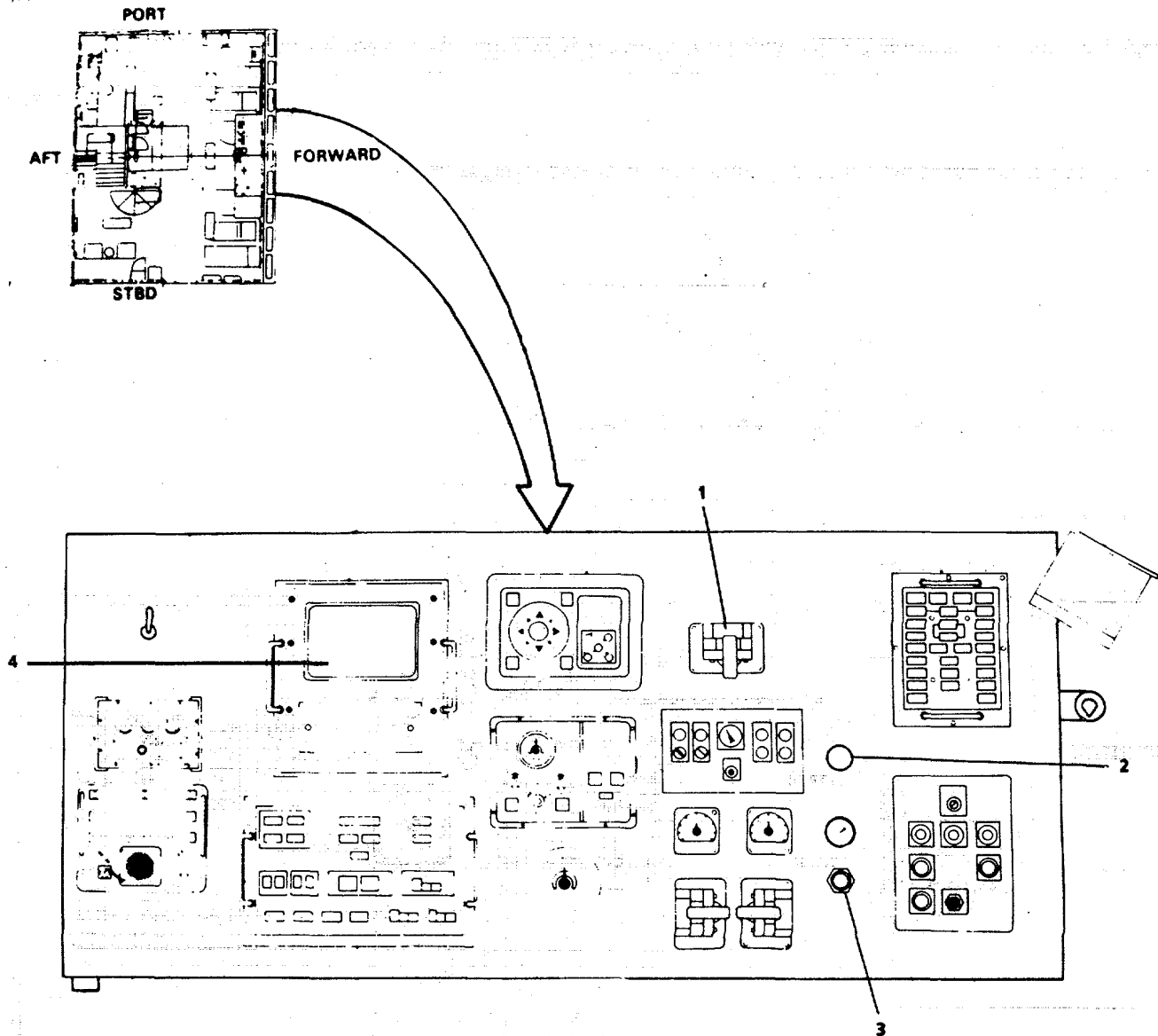

**LEGEND**



1. BOWTHRUSTER/FIRE PUMP THROTTLE/CLUTCH
2. BOWTHRUSTER ENGINE TACHOMETER
3. CONTROL AIR VALVE
4. MACHINERY PLANT MONITOR

FIGURE 2-155. Pilothouse Console.

Change 2 2-440

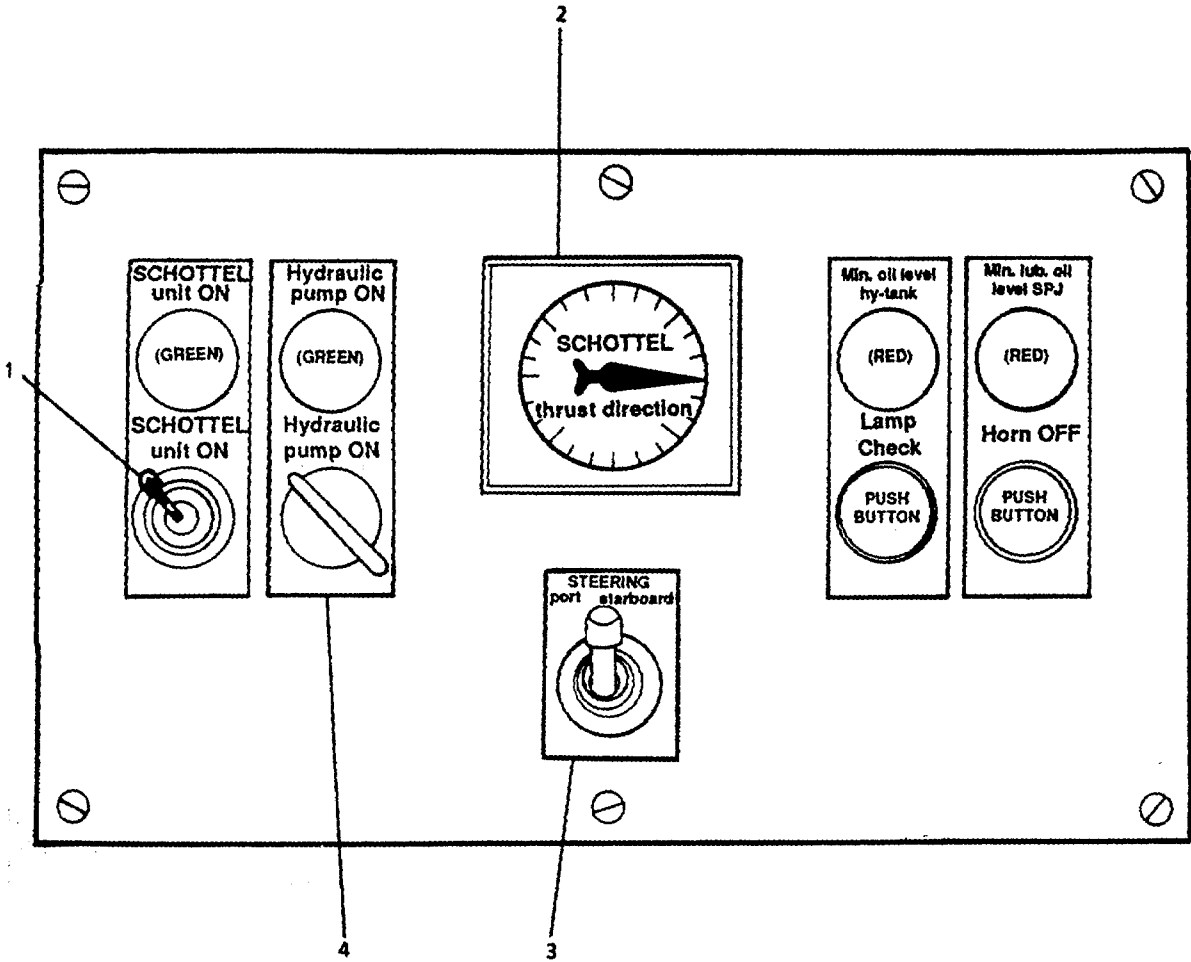

- LEGEND**
- 1. SCHOTTEL UNIT ON
  - 2. THRUST DIRECTION INDICATOR
  - 3. STEERING CONTROL JOYSTICK
  - 4. HYDRAULIC PUMP SWITCH

FIGURE 2-156. Bowthruster Waterjet Control Panel.

c. Waterjet Shutdown.

**NOTE**

Before waterjet shutdown, ensure thrust direction indicator is in aft position.

- (1) Set BOWTHRUSTER/FIRE PUMP THROTTLE/CLUTCH (1, FIGURE 2-155) to center position (neutral position) and allow engine to idle for 3 to 5 minutes.
- (2) On bowthruster Waterjet Control Panel (FIGURE 2-156) set Hydraulic pump ON switch (4) to OFF position.
- (3) Turn key (1) counterclockwise to off position and remove key.
- (4) On Bridge Console Panel (FIGURE 2-157), press BOWTHRUSTER ENGINE STOP pushbutton (2).

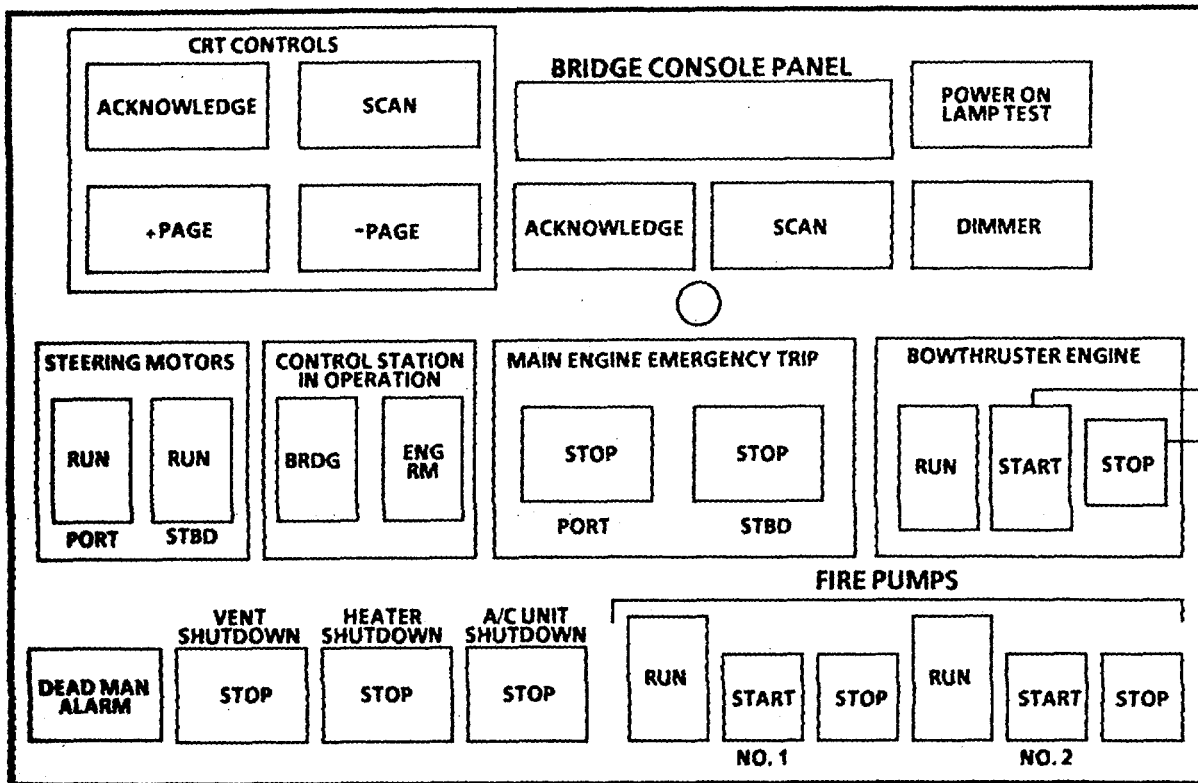

**LEGEND**

1. BOWTHRUSTER ENGINE START
2. BOWTHRUSTER ENGINE STOP

FIGURE 2-157. Bridge Console Panel.

**2-15. Halon 1301 Fire Suppression System.** The Halon Fire Suppression System consists of the Main Engine Room and the Paint Locker compartment.

a. Main Engine Boom Operation.

**WARNING**

- **All personnel must leave the engine room immediately upon activation of the Halon 1301 Fire Suppression System Alarm. System discharges 60 seconds after activation. Evacuating personnel must secure the doors as they evacuate the area.**
- **A waiting period of at least 30 minutes is required to ensure that the area has cooled and that the fire will not reignite upon entry of personnel. When a hatch or door is opened or the ventilation system is started, oxygen enters the area and dilutes the Halon.**
- **Do not reenter the space where Halon has been used to extinguish a fire unless you are wearing an oxygen breathing apparatus (OBA). Wear the OBA until the atmosphere is certified safe. Anyone suffering from the toxic effects of Halon 1301 vapor should immediately move or be moved to fresh air.**

**NOTE**

**Not applicable to vessels with FM-200 Fire Suppressant System installed. Reference paragraph 2-63 through 2-64, for FM-200 and Water Washdown System operation. Reference TM 55-1905-243-24&P, LCU-2000, FM-200 Fire Fighting System for maintenance and installation of FM-200 components.**

- (1) Surface Fire Pull Boxes (FIGURE 2-158). To activate the Halon 1301 Fire Suppression System, perform the following:
  - (a) Break glass (1) on VALVE RELEASE surface fire pull box with hammer (3).
  - (b) Pull HALON RELEASE handle (2) hard until red paint mark on cable shows. Release handle.
  - (c) Break glass (4) on CYLINDER RELEASE surface fire pull box with hammer (6).
  - (d) Pull HALON RELEASE handle (5) hard until red paint mark on cable shows. Release handle.

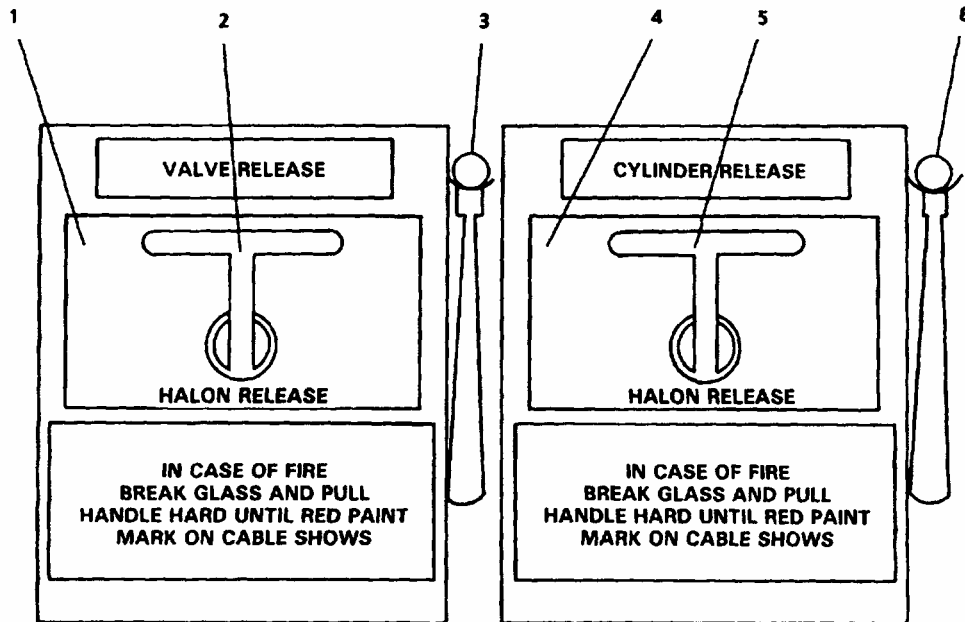

**LEGEND:**

- |                              |                                 |
|------------------------------|---------------------------------|
| 1. GLASS FRONT               | 4. GLASS FRONT                  |
| 2. VALVE RELEASE PULL HANDLE | 5. CYLINDER RELEASE PULL HANDLE |
| 3. HAMMER                    | 6. HAMMER                       |

*FIGURE 2-158. Surface Fire Pull Boxes.*

**WARNINGS**

- A waiting period of at least 30 minutes is required to ensure that the area has cooled and that the fire will not reignite upon entry of personnel. When hatch or door is opened, or the ventilation system is started, oxygen enters the area and dilutes the HALON.
- Do not reenter the space where HALON has been used to extinguish a fire unless you are wearing an oxygen breathing apparatus (OBA). Wear the OBA until the atmosphere is certified safe. Anyone suffering from the toxic effect of HALON 1301 vapor should immediately move, or be moved, to fresh air.

**NOTE**

- Alarm siren will sound in main engine room. Discharge of HALON will be delayed for 60 seconds to allow evacuation of main engine room personnel. Discharge of HALON is completed in 10 seconds.
- During the 60-second warning time, four PRESSURE OPERATED SWITCHES automatically shut down the main engine room console, two main engines, two ship service diesel generators, fuel oil supply pumps, and the ventilation system in the main engine room. Before this equipment can be restarted, the four PRESSURE OPERATED SWITCHES located near the HALON bottles on the forward bulkhead of the emergency generator room must be reset.
- The resetting of the four PRESSURE OPERATED SWITCHES does not reset the HALON 1301 Fire Suppression System. The HALON and CO<sup>2</sup> cylinders must be recharged or replaced and the pull boxes reset by depot maintenance when the LCU is docked.

(2) Reset plunger. After the fire has been extinguished, and at least 30 minutes have passed, and equipment is to be restarted, reset the four PRESSURE OPERATED SWITCHES (FIGURE 2-159) located near the HALON bottles on the forward bulkhead of the Emergency Generator Room by pushing RESET PLUNGER (1) down to the SET position.

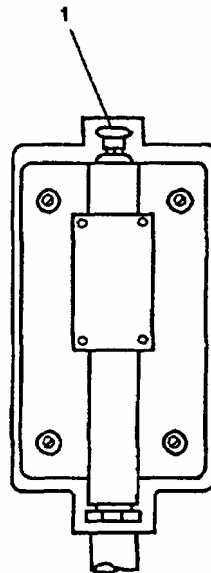

1. RESET PLUNGER

FIGURE 2-159. Pressure Operated Switch.

b. Paint Locker Halon Operation.

**WARNINGS**

- All personnel must leave the paint locker compartment immediately upon activation of the HALON 1301 fire suppression system alarm. System discharges 60 seconds after activation. Evacuating personnel must secure all hatchways and doors as they evacuate the area.
- A waiting period of at least 30 minutes is required to ensure the area has cooled and that the fire will not reignite upon entry of personnel. When hatch or door is opened or the ventilation system is restarted, oxygen enters the area and dilutes the HALON.
- Do not reenter the space where HALON has been used to extinguish a fire unless you are wearing an oxygen breathing apparatus (OBA). Wear the OBA until the atmosphere is certified safe. Anyone suffering from the toxic effect of HALON 1301 vapor should immediately move or be moved to fresh air.

**NOTES**

- Alarm siren will sound in main engine room. Discharge of HALON will be delayed for 60 seconds to allow evacuation of main engine room personnel. Discharge of HALON is completed in 10 seconds.
- During the 60-second warning time, four **PRESSURE OPERATED SWITCHES** automatically shut down the main engine room console, two main engines, two ship service generators, fuel oil supply pumps and the ventilation system in the main engine room. Before this equipment can be restarted, the four **PRESSURE OPERATED SWITCHES** located above the Halon bottles on the forward bulkhead under the ladder to the port forecastle deck must be reset.
- Resetting the four **PRESSURE OPERATED SWITCHES** does not reset the HALON 1301 Fire Suppression System. The HALON and CO2 cylinders must be recharged or replaced and the pull boxes reset by depot maintenance when the LCU is docked.
- Not applicable to vessels with FM-200 Fire Suppressant System installed. Reference paragraph 2-46 through 2-47 for FM-200 and Water Washdown System operation. Reference TM 55-1905-243-24&P, LCU-2000, FM-200 Fire Fighting System for maintenance and installation of FM-200 components.

- (1) Surface Fire Pull Boxes (FIGURE 2-158). To activate the HALON 1301 Fire Suppression System perform the following:
  - (a) Break glass (1) on VALVE RELEASE surface fire pull box with hammer (3).
  - (b) Pull HALON RELEASE handle (2) hard until red paint mark on cable shows. Release handle.
  - (c) Break glass (4) on CYLINDER RELEASE surface fire pull box with hammer (6).
  - (d) Pull HALON RELEASE handle (5) hard until red paint mark on cable shows.
- (2) Reset plunger. After the fire has been extinguished, and at least 30 minutes have passed, and equipment is to be restarted, reset the four PRESSURE OPERATED SWITCHES (FIGURE 2-159) located near the HALON bottles on the exterior bulkhead of the paint locker by pushing RESET PLUNGER (1) down to the SET position.

**2-16. Bilge/Ballast Piping System Operation.**

- a. Ballast Operation. Fill ballast tanks from sea chest as follows:
  - (1) Close all valves in Bilge/Ballast Piping System (FIGURE 2-160).
  - (2) Open BB-22, ISLN-SEA CHEST (21).
  - (3) Open BB-35, SEA CHEST VENT ISOLATION (24) and BB-36, SEA CHEST VENT (23).
  - (4) Open BB-23, SEA CHEST SUCT (22).
  - (5) Open BB-25, ISLN-SEA CHEST (18).
  - (6) Open BB-24, SUCT-BILGE BALLAST PUMP (20).
  - (7) Select tanks to be filled.
    - (a) If Sea Water Tank 1 (SW-1) is to be filled,
      - 1 Open BB-17, SUPPLY TO SW1 and SW-2S and SW-2P (6).
      - 2 Open BB-1, ISLN TK SW-1 (37). (Open BB-1 in bowthruster room or from main deck.)
    - (b) If SW2 tanks are to be filled,
      - 1 Open BB-17, SUPPLY TO SW-1 and SW-2S and SW-2P (6).
      - 2 If port SW-2 is to be filled, open BB-2, ISLN TK SW-2P (36).
      - 3 If starboard SW-2 tank is to be filled, open BB-3, ISLN TK SW-2S (38).



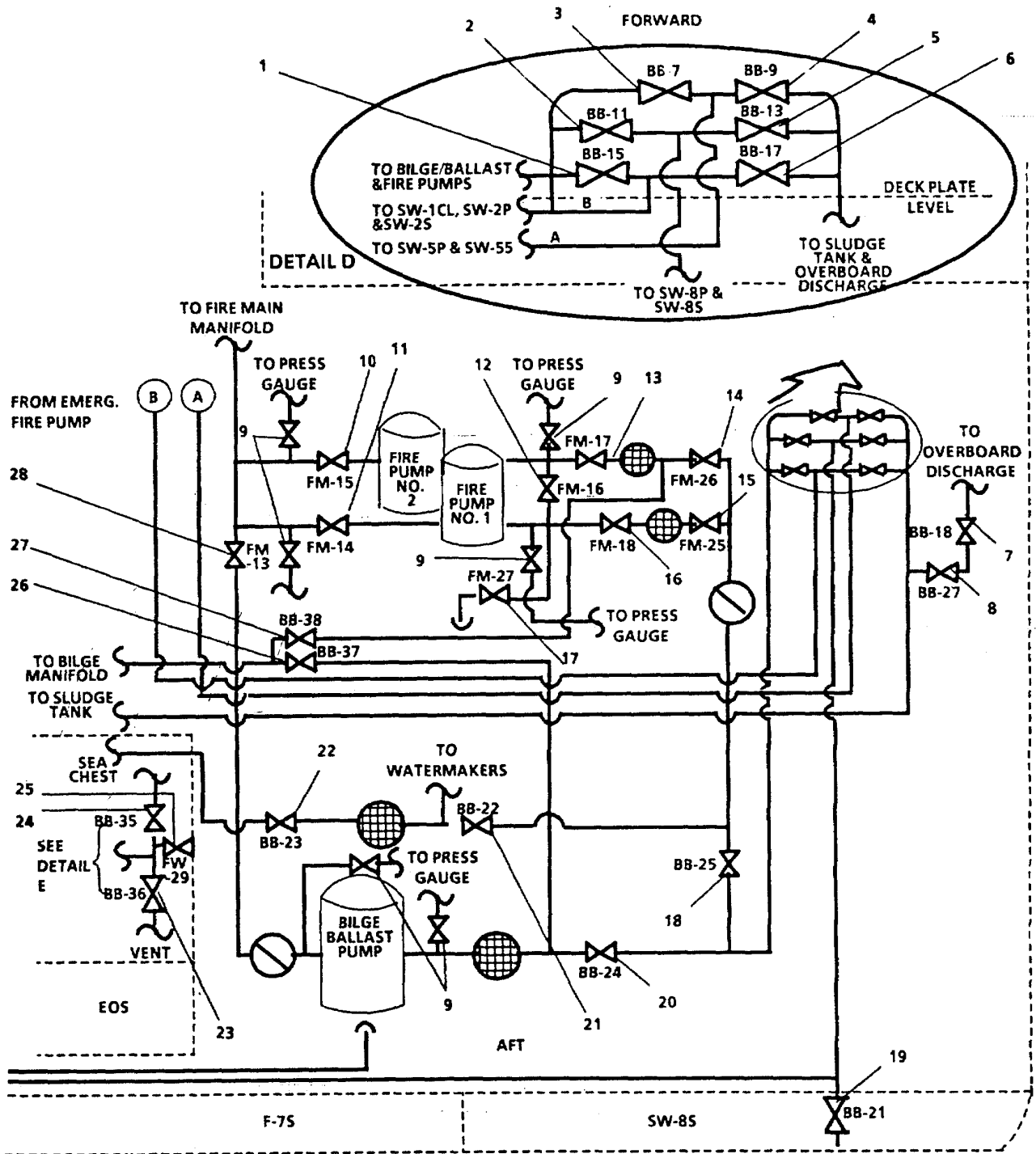

FIGURE 2-160. Bilge/ballast Piping System (Sheet 1 of 4).

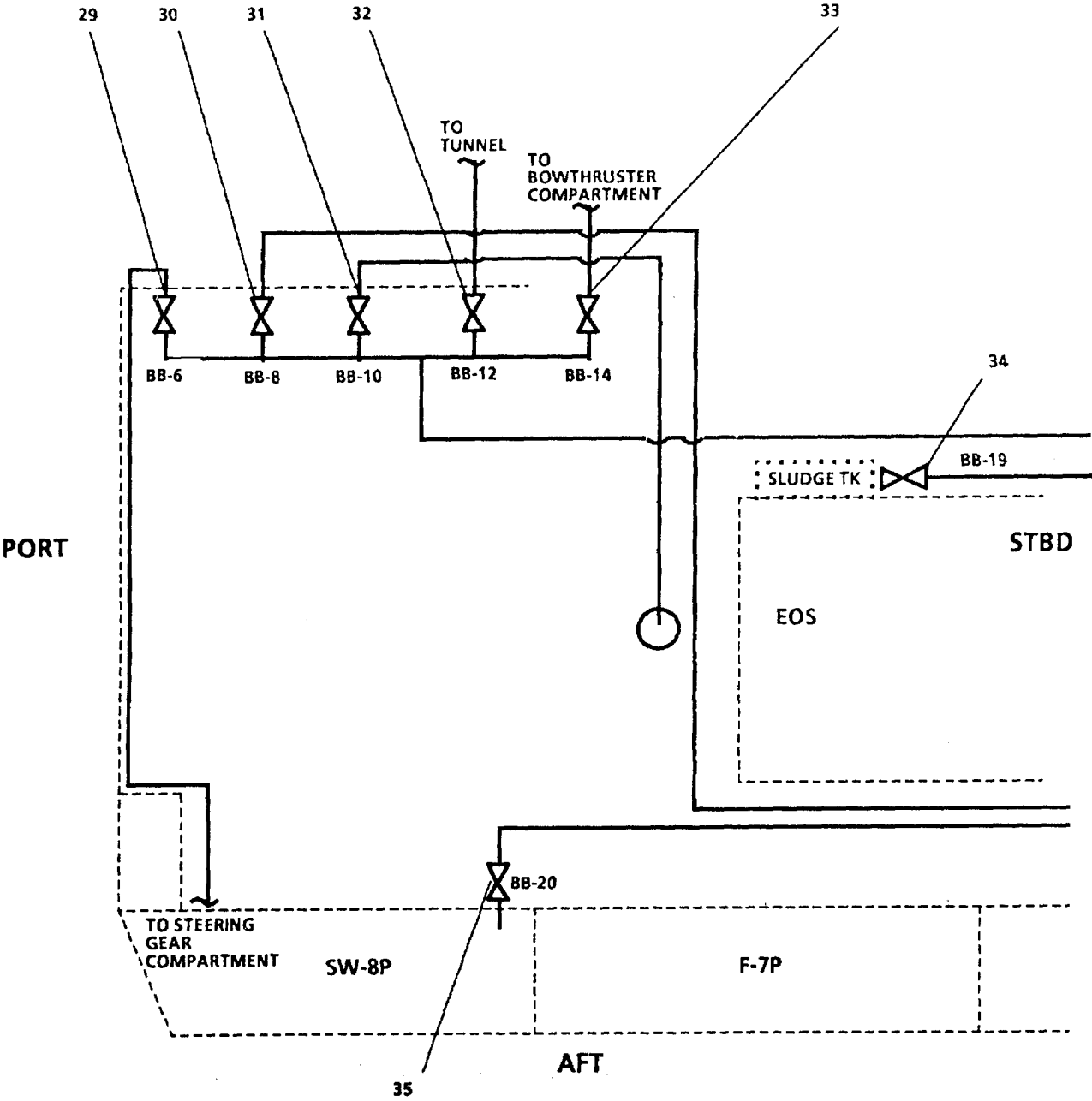

FIGURE 2-160. Bilge/Ballast Piping System (Sheet 2 of 4).

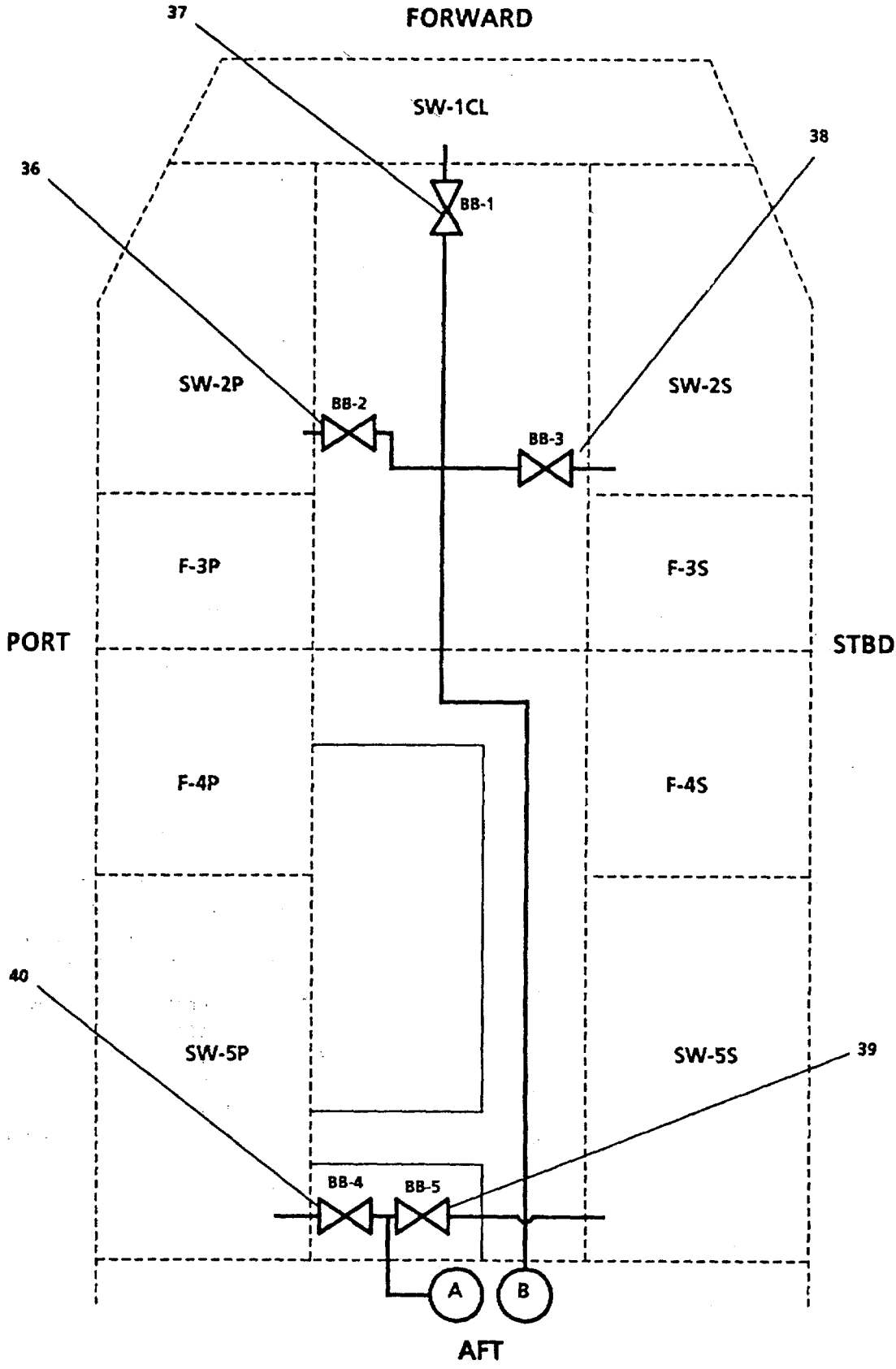
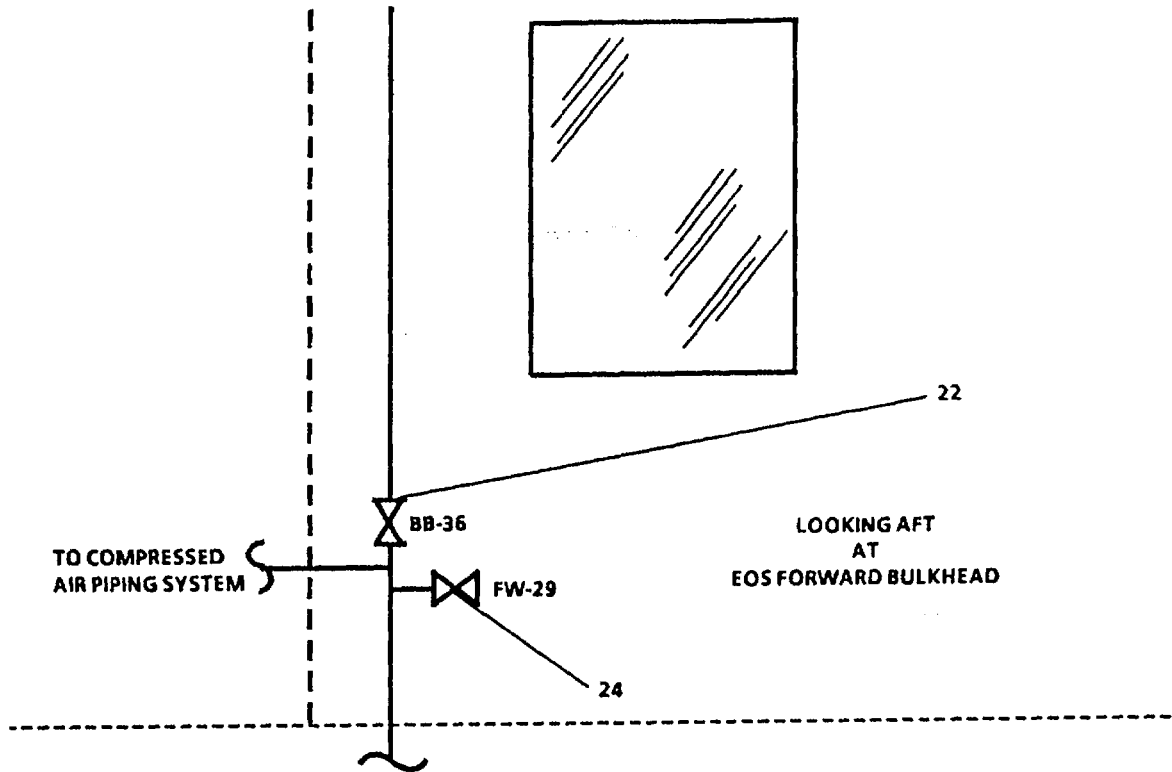

FIGURE 2-160. Bridge/Ballast Piping System (Sheet 3 of 4).

DETAIL F



LEGEND

- |   |   |
|---|---|
| <ul style="list-style-type: none"> <li>1. 88-15, SUCT FR SW-1 &amp; SW-25 &amp; SW-2P</li> <li>2. BB-11. SUCT FR SW-BS &amp; SW-8P</li> <li>3. BB-7, SUCT FR SW-5S &amp; SW-5P</li> <li>4. BB-9, SUPPLY TO SW-5S &amp; SW-5P</li> <li>5. 8-13, SUPPLY TO SW-8S &amp; SW-BP</li> <li>6. BB-17, SUPPLY TO SW-1 &amp; SW-2S &amp; SW-2P</li> <li>7. 88-18, TO OVBD DISCH</li> <li>8. BB-27, TO OVBD DISCH</li> <li>9. PRESSURE GAUGE ISOLATION</li> <br/> <li>10 FM-15o NO. 2 FIRE PUMP DISCH</li> <li>11 FM-14, NO. 1 FIRE PUMP DISCH</li> <li>12 FM-16, FIRE PUMP 1&amp;2 SUCT CROSS CONN</li> <li>13 FM-17, FIRE PUMP NO. 2 SUCT</li> <li>14 FM-26, NO. 2 FIRE PUMP STRAINER ISOLATION</li> <li>15 FM-25, NO. 1 FIRE PUMP STRAINER ISOLATION</li> <li>16 FM-18, FIRE PUMP NO. 1 SUCT</li> <li>17 FM-27, ENG RM EMERG BILGE SUCT</li> <li>18 BB-25, ISLN-SEA CHEST</li> <li>19 BB-21, ISLN-TK SW-85</li> <li>20 BB-24, SUCT-BILGE/BALLAST PUMP</li> <li>40 BB4, ISLN TK SW-SP</li> </ul> | <ul style="list-style-type: none"> <li>21. BB-22, ISLN - SEA CHEST</li> <li>22. BB-23, SEA CHEST SUCT</li> <li>23. BB-36, SEACHEST VENT</li> <li>24. BB-35, SEACHEST VENT ISOLATION</li> <li>25 FW-29, SEA CHEST HOT FW CONN</li> <li>26 BB-37, CROSS CONN TO BILGE MANIFOLD</li> <li>27 BB-38, CROSS CONN FIRE PUMP SUCT TO BILGE MANIFOLD</li> <li>28 FM-13, FIREMAN &amp; BALLAST CROSS CONN</li> <li>29 BB-6, BILGE SUCT-STRG GR COMPT</li> <li>30 BB BILGE SUCT-ENG RM STBD</li> <br/> <li>31 BB-10, BILGE SUCT-ENG RM PORT</li> <li>32 BB-12, BILGE SUCT-TUNNEL</li> <li>33 BB-14, BILGE SUCT BOWTHRUSTER ENG RM</li> <li>34 BB-19, DISCH TO SLUDGE TK</li> <li>35 BB-20, ISLN-TK SW-8P</li> <li>36 BB-2, ISLN TK SW-2P</li> <li>37 BB-1, ISLN TK SW-1</li> <li>38 BB-3, ISLN TK SW-25</li> <li>39 BB-5, ISLN TK SW-5S</li> </ul> |
|---|---|

FIGURE 2-160. Bilge/Ballast Piping System (Sheet 4 of 4).

- (c) If SW5 tanks are to be filled,
  - 1 Open BB-9, SUPPLY TO SW-5S and SW-5P (4).
  - 2 If port SW-5 tank is to be filled, open BB-4, ISLN TK SW-5P (40).
  - 3 If starboard SW-5 tank is to be filled, open BB-5, ISLN TK SW-5S (39).
- (d) If SW-8 tanks are to be filled,
  - 1 Open BB-13, SUPPLY TO SW-8S and SW-8P (5).
  - 2 If port SW-8 is to be filled, open BB-20, ISLN-TK SW-8P (35).
  - 3 If starboard SW-8 is to be filled, open BB-21, ISLN-TK SW-8S (19).
- (8) Activate tank level indicator system.
- (9) On Bilge/Ballast Pump Motor Controller (FIGURE 2-161), set circuit breaker (1) to ON position, press START pushbutton (2).
- (10) When selected SW tank has reached the required level, press STOP pushbutton (3).

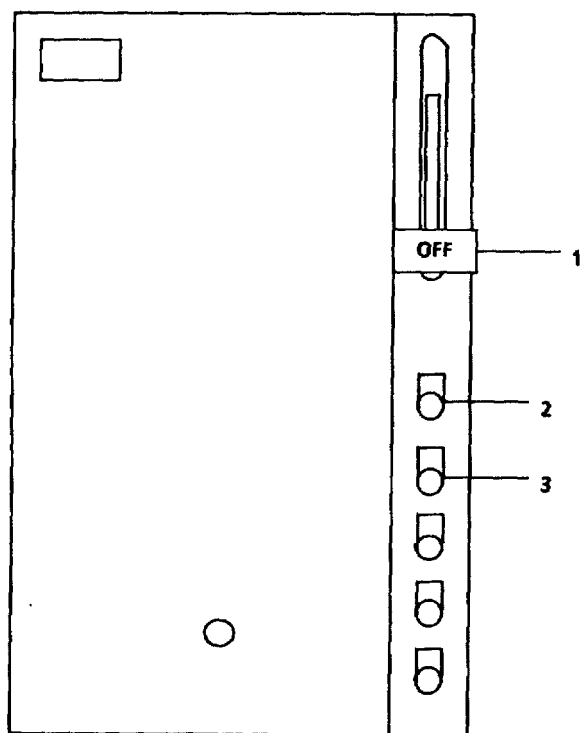

**LEGEND**  
 1. CIRCUIT BREAKER HANDLE  
 2. START PUSHBUTTON  
 3. STOP PUSHBUTTON

FIGURE 2-161. Bilge/Ballast Pump Motor Controller.

- (11) Close all valves in the bilge/ballast/piping system.
- b. Deballast Operation Perform deballast operations as follows:
- (1) Close all valves in the Bilge/Ballast Piping System (FIGURE 2-160).
  - (2) Open BB-24, SUCT-BILGE/BALLAST PUMP (20).
  - (3) Open BB-27, TO OVBD DISCH (8).
  - (4) Open BB-18, OVBD DISCH (7).
  - (5) Select tanks to be deballasted.
    - (a) To deballast SW1,
      - 1 Open BB-15, SUCT FM SW-1 and SQ-2S and SW-2P (1).
      - 2 Open BB-1, ISLN TK SW-1 (37).
    - (b) To deballast SW-2 tanks,
      - 1 Open BB-15, SUCT FR SW-1 and SW-2S and SW-2P (1).
      - 2 To deballast port SW2 tank, open BB-2, ISLN TK SW-2P (36).
      - 3 To deballast starboard SW2 tank, open BB-3, ISLN TK SW-2S (38).
    - (c) To deballast SW5 tanks,
      - 1 Open BB-7, SUCT FR SW-5S and SW-5P (3).
      - 2 To deballast port SW5, open BB-4, ISLN TK SW-5P (40).
      - 3 To deballast starboard SW5, open BB-5, ISLN TK SW-5S (39).
    - (d) To deballast SW8 tanks,
      - 1 Open BB-11, SUCT FR SW-8S and SW-8P (2).
      - 2 To deballast SW8 port, open BB-20, ISLN-TK SW-8P (35).
      - 3 To deballast SW8 starboard, open BB-21, ISLN-TK SW-8S (19).
  - (6) Activate tank level indicator.
  - (7) On Bilge/Ballast Pump Motor Controller (FIGURE 2-161), circuit breaker (1) to ON position, press START pushbutton (2).
  - (8) When selected SW tank has reached the required level, press STOP pushbutton (3).
  - (9) Close all valves in the bilge/ballast piping system.

c. Bilge Pumping Operation.

- (1) Close all valves in bilge/ballast piping system.
- (2) Open BB-24, SUCT-BILGE/BALLAST PUMP (20, FIGURE 2-160).
- (3) Open BB-37, CROSS CONN TO BILGE MANIFOLD (26).
- (4) Select where bilge water is to be pumped.
  - (a) If bilge water is to be pumped overboard,
    - 1 Open BB-27, TO OVBD DISCH (8).
    - 2 Open BB-18, OVBD DISCH (7).
  - (b) If bilge water is to be pumped into sludge tank, open BB-19, DISCH TO SLUDGE TK (34).
- (4) Select bilge to be pumped.
  - (a) If steering gear bilge is to be pumped, open BB-6, BILGE SUCT-STRG GR COMPT (29).
  - (b) If engine room starboard bilge is to be pumped, open BB-8, BILGE SUCT ENG RM STBD (30).
  - (c) If engine room port bilge is to be pumped, open BB-10, BILGE SUCT-ENG RM PORT (31).
  - (d) If tunnel bilge is to be pumped, open BB-12, BILGE SUCT-TUNNEL (32).
  - (e) If bowthruster bilge is to be pumped, open BB-14, BILGE SUCT-BOW THRUSTER ENG RM (33).
- (5) On Bilge/Ballast Pump Motor Controller (FIGURE 2-161) set circuit breaker (1) to ON position, press START pushbutton (2).
- (6) When bilge of selected compartment has been emptied, press STOP pushbutton (3).
- (7) Close all valves in the bilge/ballast piping system.

## 2-17. Lube Oil Purification and Transfer Piping System Operation.

- a. Lube Oil Purifier/Clarifier Operation. Perform lube oil purifier/clarifier operation as follows:

**CAUTION**

- It is very easy to misalign the valves and pump oil from one main engine to another. Be very positive of the valve alignment prior to putting the system in operation.
- Never operate an engine without lubricating oil in sump. This will cause serious internal damage to the engine.
- Due to the limited capacity of the purifier/clarifier only oil from one engine at a time may be purified/clarified.
- Clarifier can operate as a separator also; however, operation as a separator WILL VOID WARRANTY. Do NOT pour water into bowl upon start-up.

(1) Preheat Lubrication Oil.

- (a) On Main Switchboard (FIGURE 2-162), ensure AUXILIARY MACHINERY MCC circuit breaker (1) is in the ON position.

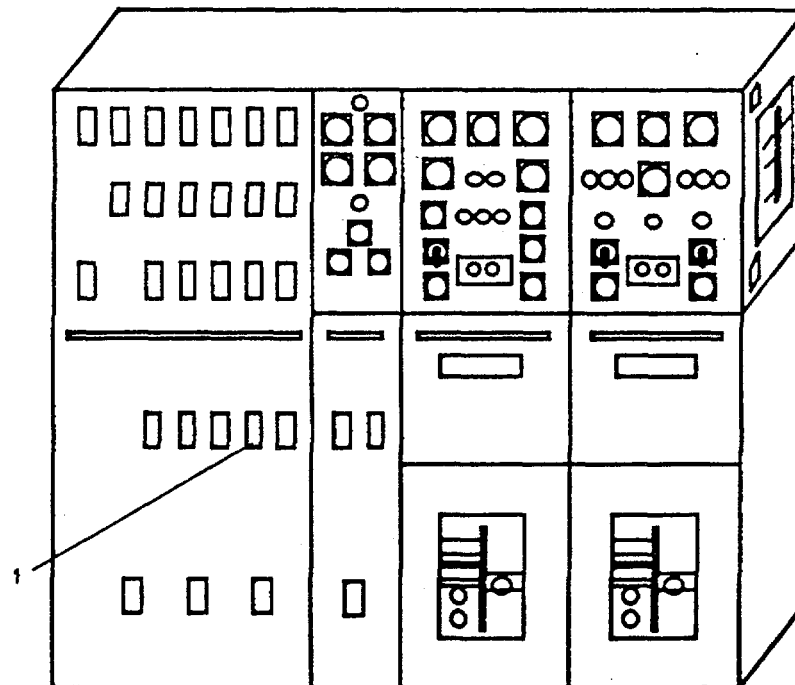
**LEGEND**

1. AUXILIARY MACHINERY MCC

FIGURE 2-162. Main Switchboard.

Change 2 2-455



- (1) (b) On Auxiliary Machinery Motor Control Center (FIGURE 2-163) set L.O. PURIFIER circuit breaker to the ON position.
- (c) Set L.O. PURIFIER HEATER circuit breaker (2) to the ON position.

**NOTE**

L.O. Purifier Heater is used if engine oil temperature is below 180

- (d) On Lube Oil Heater Switch (FIGURE 2-164) release LOCK (3), press START pushbutton (1).
- (e) Close all valves in the Lube Oil Purification and Transfer Piping System (FIGURE 2-165).
- (f) If L.O. Purifier Heater is to be used, open LO-9, PRE-HEATER SUPPLY (27, FIGURE 2-165) and LO-8, PRE-HEATER OUTLET (29).
- (g) If L.O. Purifier Heater is NOT to be used, open LO-7, PRE-HEATER BY-PASS (30).
- (h) If STBD Main Engine lube oil is to be purified:
  - 1. Open LO-19, SUMP SUCT-STBD ENG (17).
  - 2. Open LO-15,-PRE-LUBE/PURIFIER SUCT (23).
  - 3. Open LO-25, SUMP SUPPLY/Purifier RTN - STBD ENG (15).
  - 4. Ensure LO-17, RDCN GEAR SUCT-STBD (22) is closed.
- (i) if Port Main Engine lube oil is to be purifier:
  - 1 Open LO-18, SUMP SUCT-PORT ENG (12).
  - 2 Open LO-14, PRE-LUBE/PURIFIER SUCT (14).
  - 3 Open LO-24,SUMP SUPPLY/PURIFIER RTN PORT ENG (6).
  - 4. Ensure LO-16, RDCN GEAR SUCT-PORT (4) is closed.
- (j) Open ILO06, LO PURIFIER DISCH (31).
- (2) Start L.O. Purifier.
  - (a) On L.O. Purifier TYPE-I Motor Switch (FIGURE 2-166) release LOCK (3), press START pushbutton (1).
  - (b) Wait 5 minutes for bowl inside purifier to gain speed.
  - (c) Open LO-6, LO PURIFIER DISCH (31, FIGURE 2-165).
  - (d) Slowly open LO-11, PURIFIER SUCTION (32, FIGURE 2-165) until oil is visible in sight glass on top of purifier.

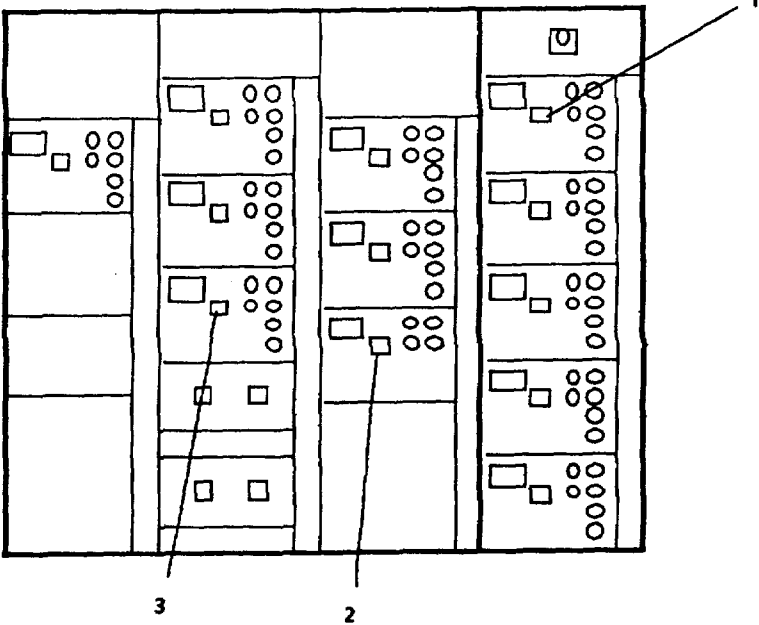

- LEGEND**
- 1. LUBE OIL PURIFIER (P205-6)
  - 2. L. O. PURIFIER HEATER (P205-3)
  - 3. DIRTY L. O. PUMP (P205-12)

FIGURE 2-163. Auxiliary Machinery Motor Control Center.

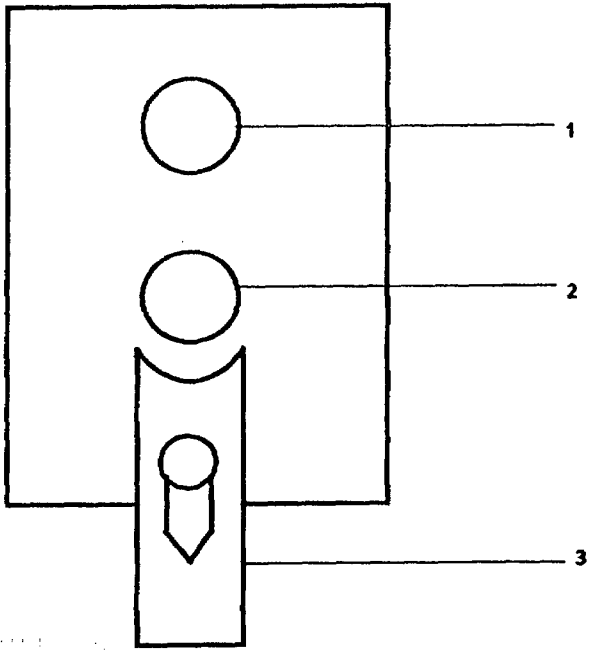

- LEGEND**
- 1. START
  - 2. STOP
  - 3. LOCK

FIGURE 2-164. Lube Oil Heater Switch.

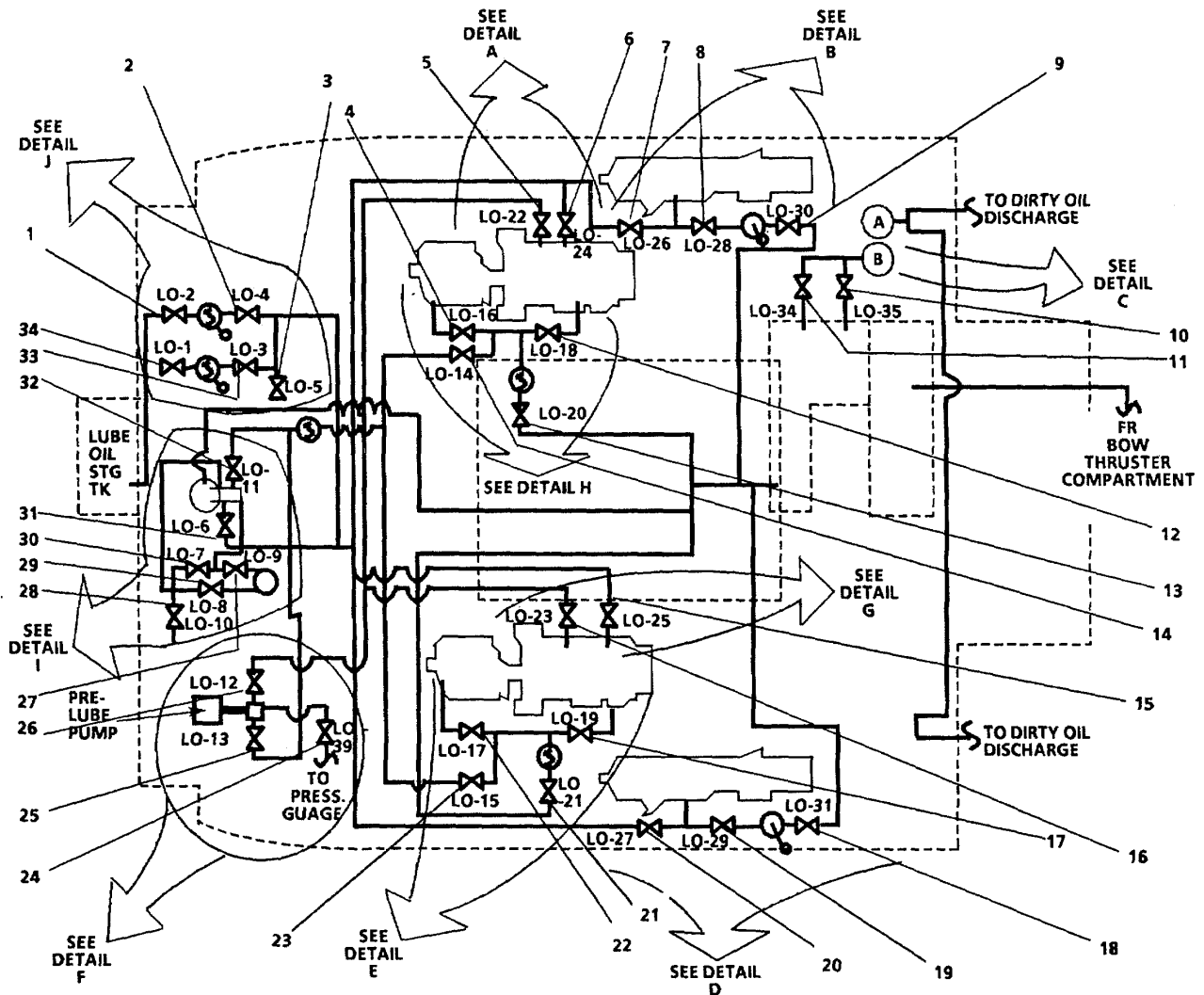

**LEGEND**

- |    |  |    |                               |
|----|--|----|-------------------------------|
| 1  | LO-2, STORAGE TK SUPPLY                  | 21 | LO-21, MN ENG SUMP DISCH      |
| 2  | LO-4, HAND PUMP NO. 2 DISCH              | 22 | LO-17, RDCN GEAR SUCT-STBD    |
| 3  | LO-5, HAND SUPPLY                        | 23 | LO-15, PRE-LUBE PURIFIER SUCT |
| 4  | LO-16, RDCN GEAR SUCT-PORT               | 24 | LO-39, PRESSURE GAGE ISLN     |
| 5  | LO-22, PRE-LUBE RETURN-PORT ENG          | 25 | LO-13, PRE-LUBE PUMP SUCTION  |
| 6  | LO-24, SUMP SUPPLY/PURIFIER RTN-PORT ENG | 26 | LO-12, PRE-LUBE PUMP DISCH    |
| 7  | LO-26, SUMP SUPPLY                       | 27 | LO-9, PRE-HEATER SUPPLY       |
| 8  | LO-28, SUMP SUCT-SSDG                    | 28 | LO-10, PRE-HEATER VENT        |
| 9  | LO-30, SUMP DISCH-SSDG                   | 29 | LO-8, PRE-HEATER OUTLET       |
| 10 | LO-35, SLUDGE TK SUCT                    | 30 | LO-7, PRE-HEATER BY-PASS      |
| 11 | LO-34, DIRTY OIL TK SUCT                 | 31 | LO-6, LO PURIFIER DISCH       |
| 12 | LO-18-SUMP SUCT-PORT ENG                 | 32 | LO-11, PURIFIER SUCTION       |
| 13 | LO-20, MN ENG SUMP DISCH                 | 33 | LO-3, HAND PUMP NO. 1 DISCH   |
| 14 | LO-14, PRE-LUBE PURIFIER SUCT            | 34 | LO-1, STORAGE TK SUPPLY       |
| 15 | LO-25, SUMP SUPPLY/PURIFIER RTN-STBD ENG | 35 | LO-33, SUMP DISCH-BOW ENG     |
| 16 | LO-23, PRE-LUBE RETURN-STBD ENG          | 36 | HAND SUPPLY                   |
| 17 | LO-19, SUMP SUCT-STBD ENG                | 37 | LO-32, SUMP SUCT-BOW ENG      |
| 18 | LO-31, SUMP DISCH-SSDG                   | 38 | LO-37, DIRTY OIL PUMP DISCH   |
| 19 | LO-29, SUMP SUCT-SSDG                    | 39 | LO-36, DIRTY OIL PUMP SUCT    |
| 20 | LO-27, SUMP SUPPLY                       |    |                               |

FIGURE 2-165. Lube Oil Purification and Transfer Piping System (Sheet 1 of 8).

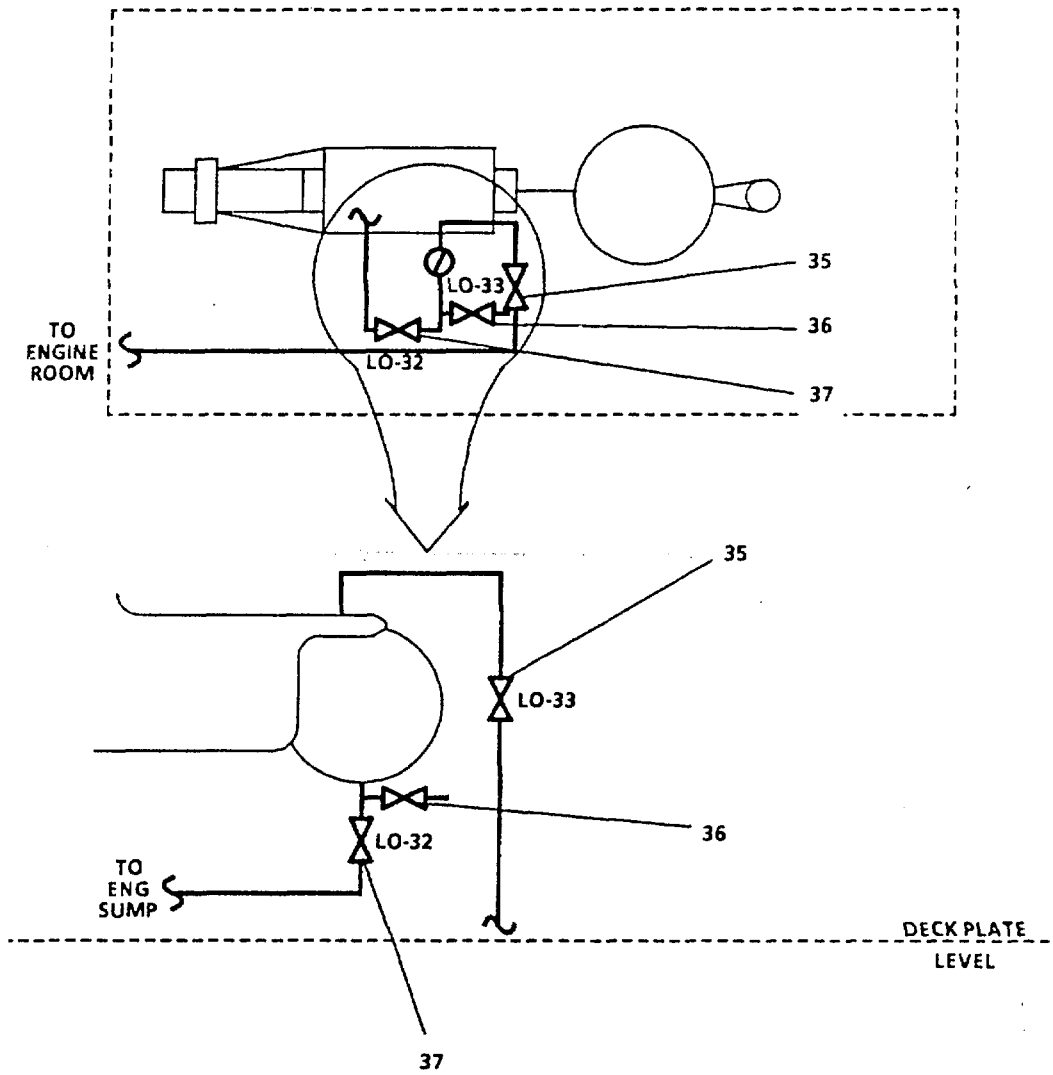
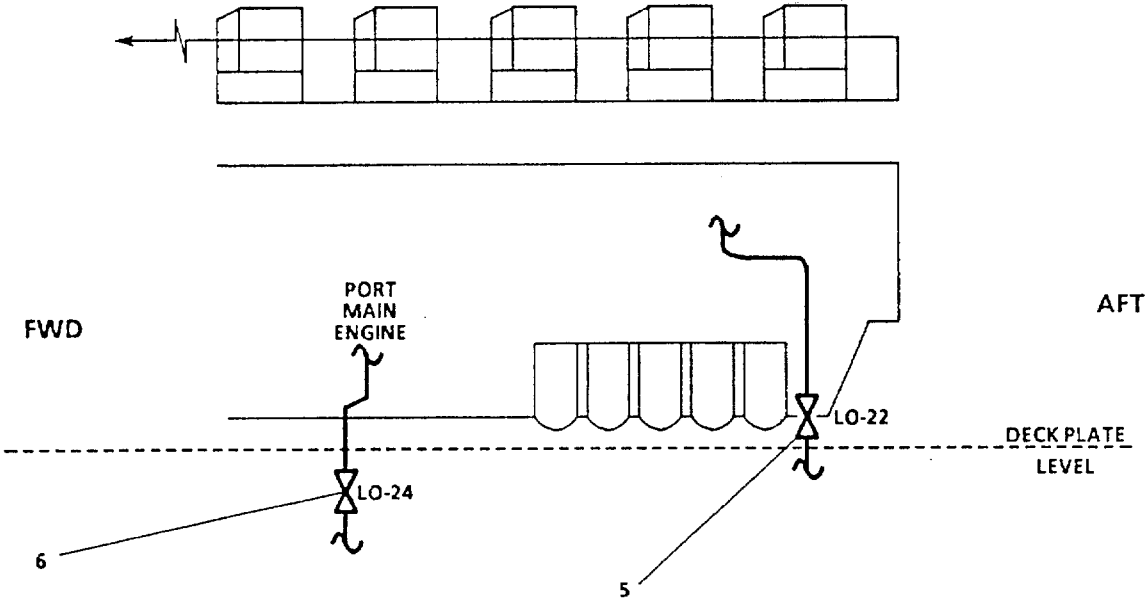

FIGURE 2-165. Lube Oil Purification and Transfer Piping System (Sheet 2 of 8).

DETAIL A



DETAIL B

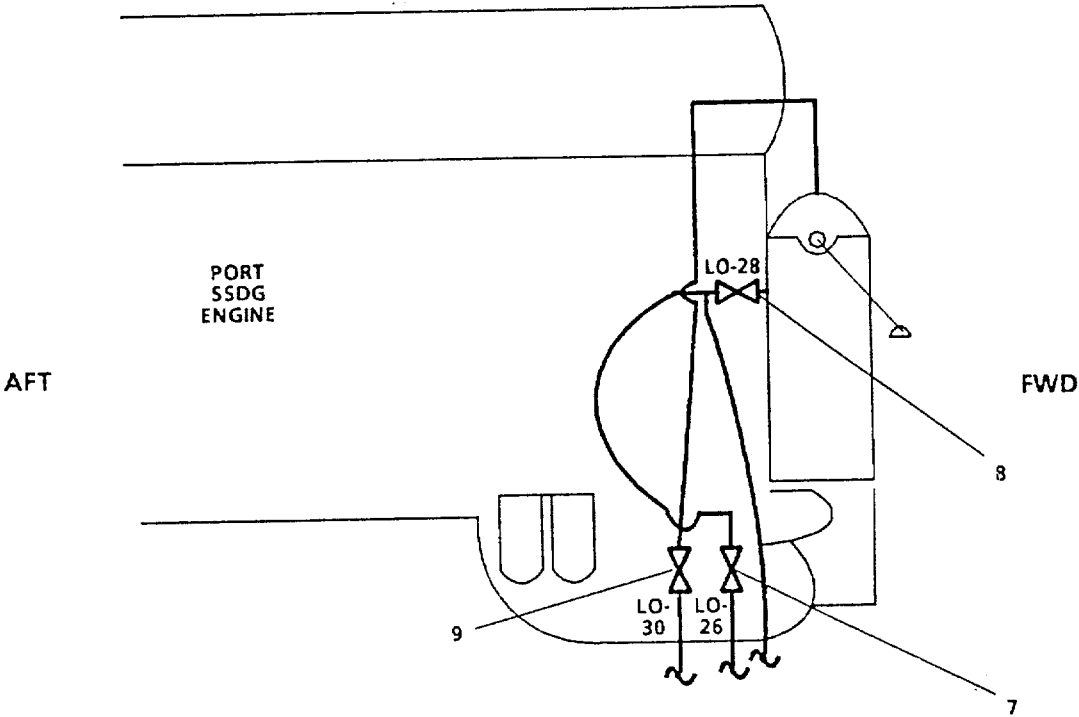

FIGURE 2-165. Lube Oil Purification and Transfer Piping System (Sheet 3 of 8).

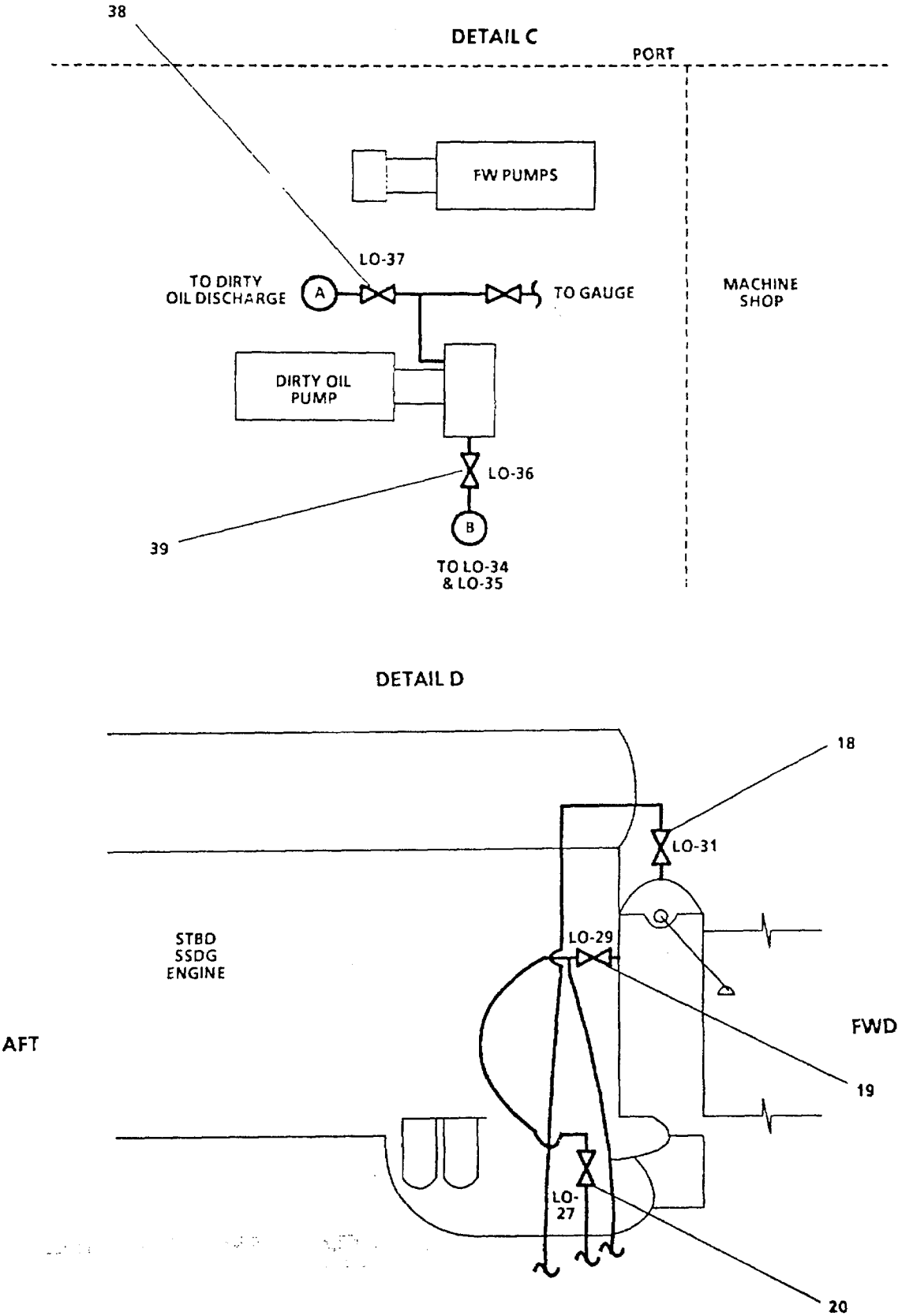

FIGURE 2-165. Lube Oil Purification and Transfer Piping System (Sheet 4 of 8).

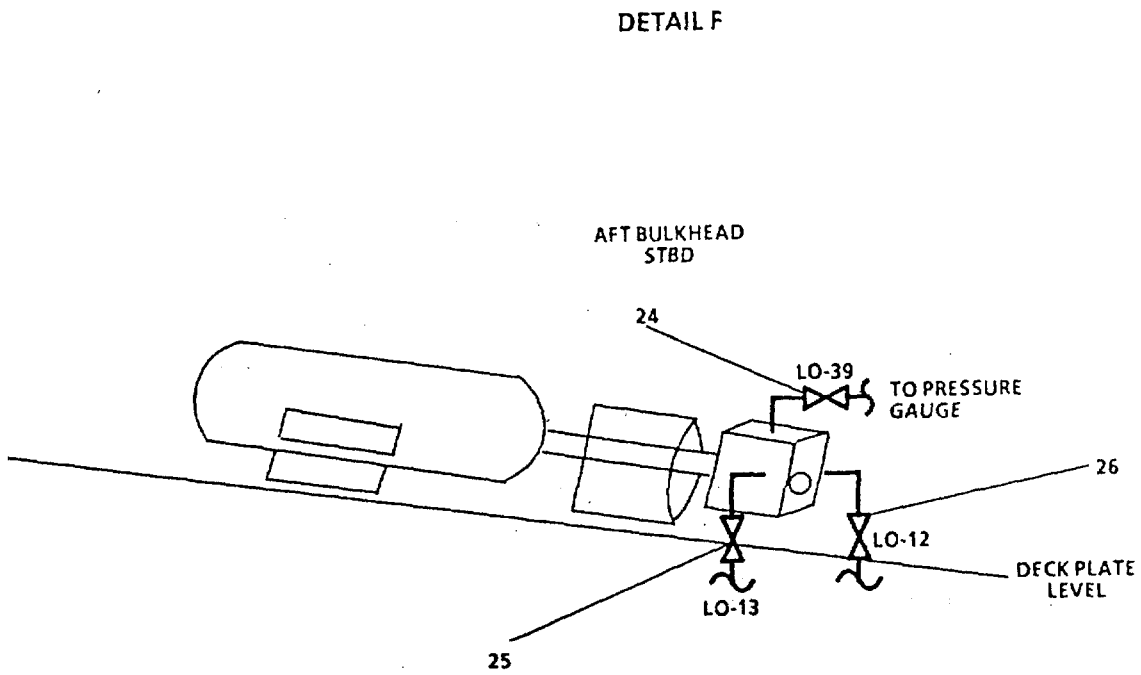
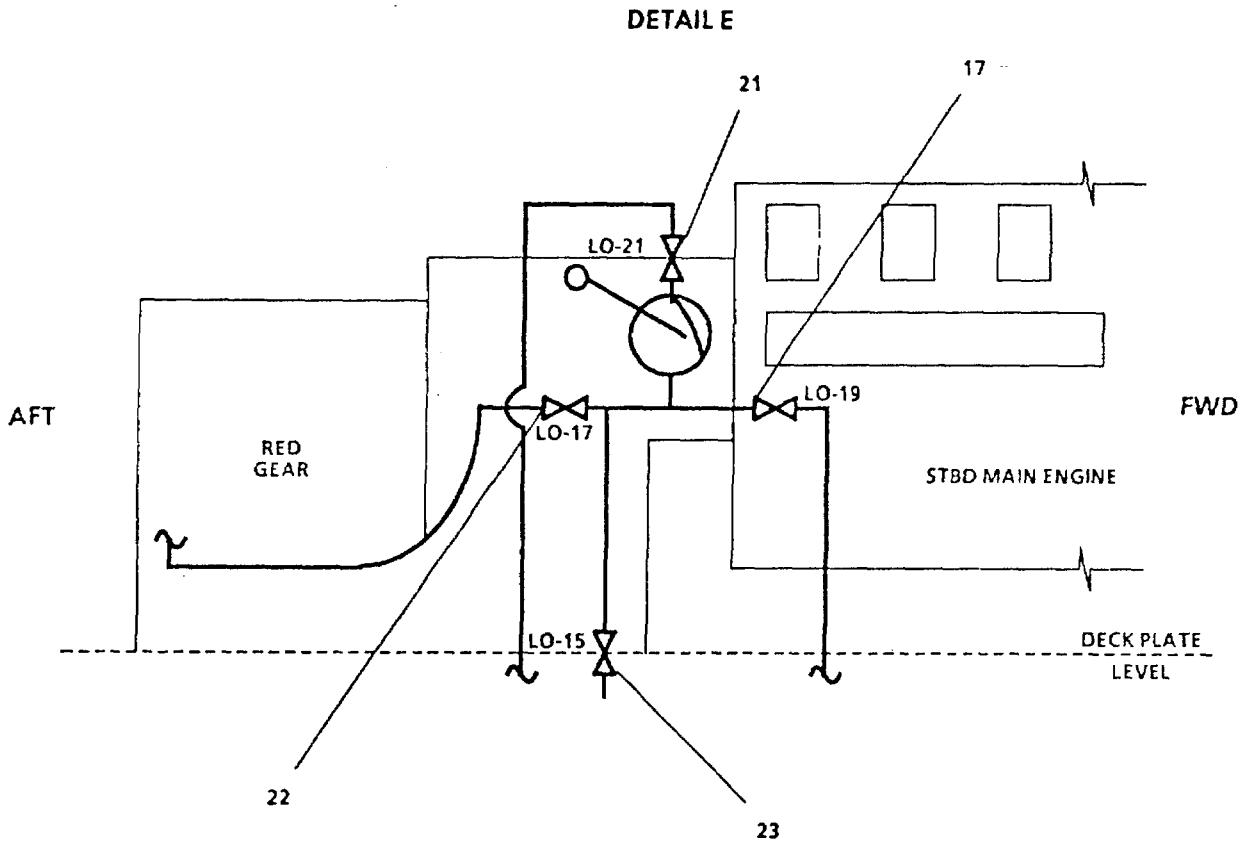
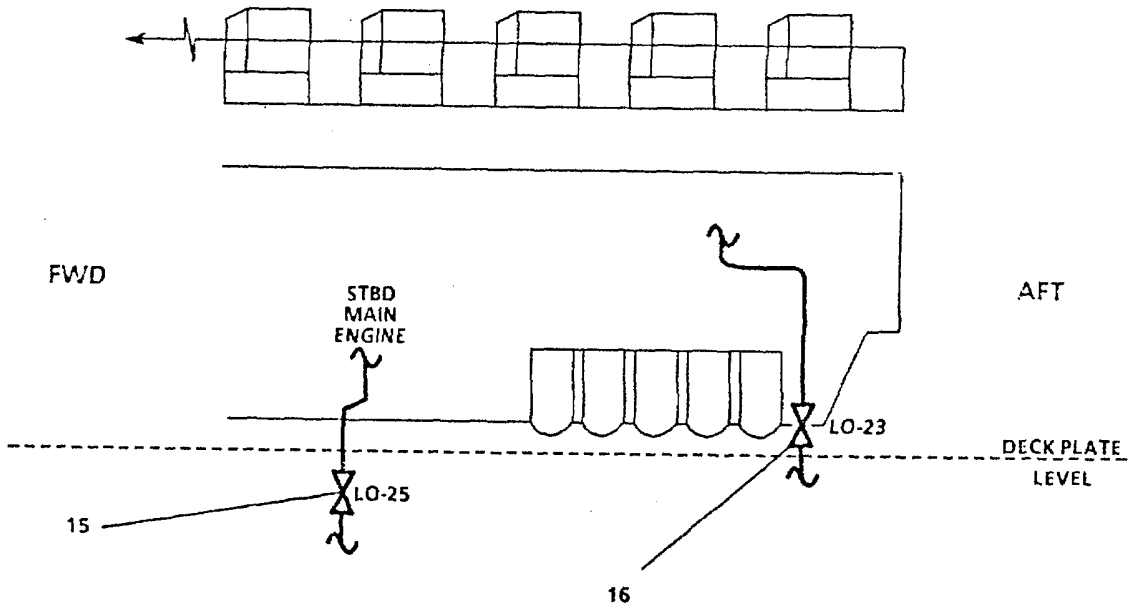

FIGURE 2-165. Lube Oil Purification and Transfer Piping System (Sheet 5 of 8).  
2-462

DETAIL G



DETAIL H

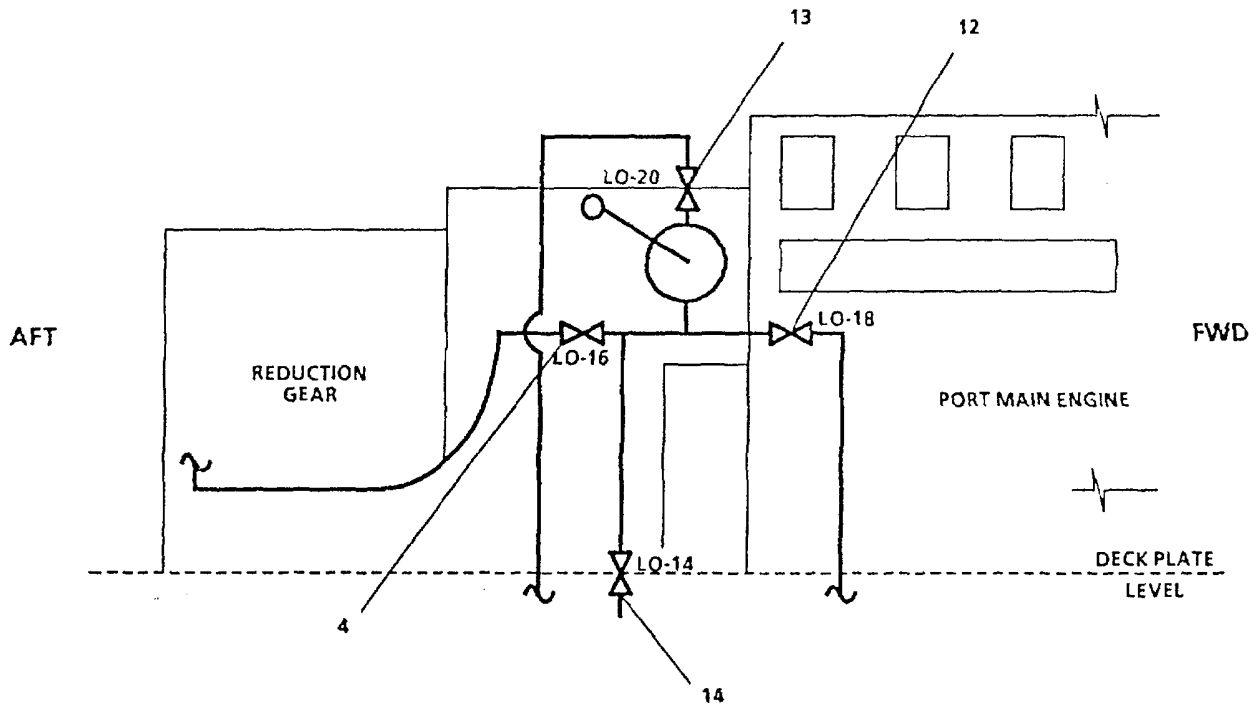

FIGURE 2-165. Lube Oil Purification and Transfer Piping System (Sheet 5 of 8).



DETAIL I  
LOOKING AFT

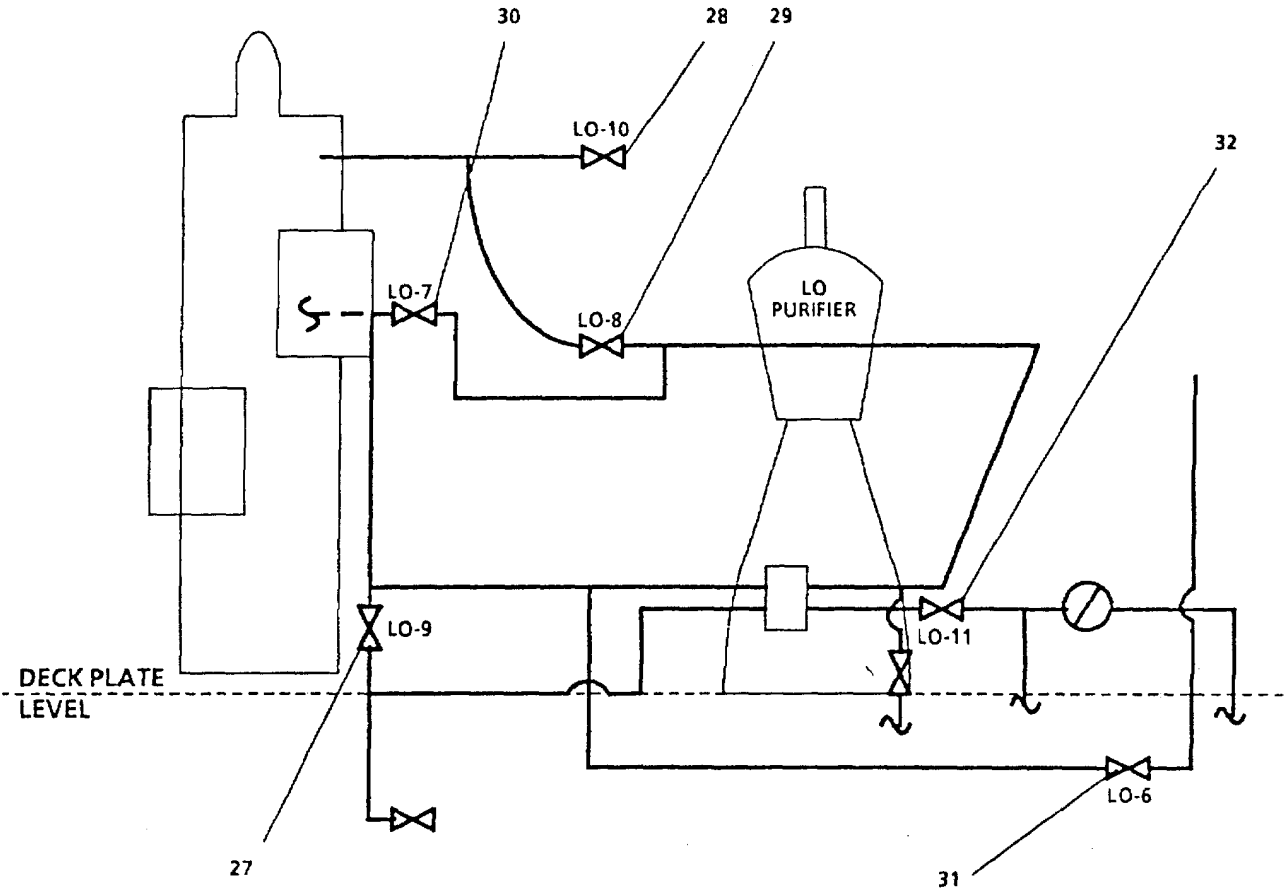
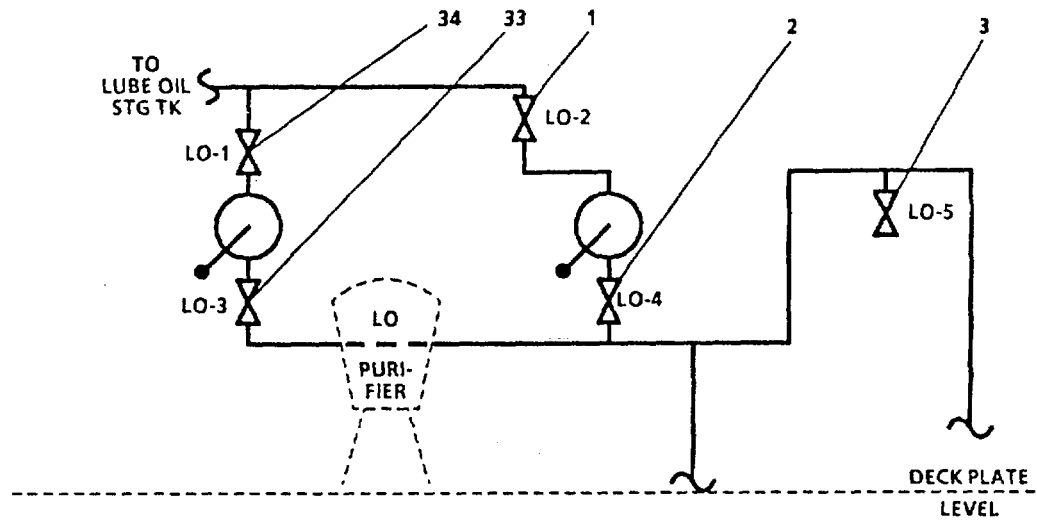

FIGURE 2-165. Lube Oil Purification and Transfer Piping System (Sheet 5 of 8).

DETAIL J



LEGEND

- |    |  |    |                               |
|----|--|----|-------------------------------|
| 1  | LO-2, STORAGE TK SUPPLY                  | 21 | LO-21, MN ENG SUMP DISCH      |
| 2  | LO-4, HAND PUMP NO. 2 DISCH              | 22 | LO-17, RDCN GEAR SUCT-STBD    |
| 3  | LO-5, HAND SUPPLY                        | 23 | LO-15, PRE-LUBE PURIFIER SUCT |
| 4  | LO-16, RDCN GEAR SUCT-PORT               | 24 | LO-39, PRESSURE GAGE ISLN     |
| 5  | LO-22, PRE-LUBE RETURN-PORT ENG          | 25 | LO-13, PRE-LUBE PUMP SUCTION  |
| 6  | LO-24, SUMP SUPPLY/PURIFIER RTN-PORT ENG | 26 | LO-12, PRE-LUBE PUMP DISCH    |
| 7  | LO-26, SUMP SUPPLY                       | 27 | LO-9, PRE-HEATER SUPPLY       |
| 8  | LO-28, SUMP SUCT-SSDG                    | 28 | LO-10, PRE-HEATER VENT        |
| 9  | LO-30, SUMP DISCH-SSDG                   | 29 | LO-8, PRE-HEATER OUTLET       |
| 10 | LO-35, SLUDGE TK SUCT                    | 30 | LO-7, PRE-HEATER BY-PASS      |
| 11 | LO-34, DIRTY OIL TK SUCT                 | 31 | LO-6, LO PURIFIER DISCH       |
| 12 | LO-18-SUMP SUCT-PORT ENG                 | 32 | LO-11, PURIFIER SUCTION       |
| 13 | LO-20, MN ENG SUMP DISCH                 | 33 | LO-3, HAND PUMP NO. 1 DISCH   |
| 14 | LO-14, PRE-LUBE PURIFIER SUCT            | 34 | LO-1, STORAGE TK SUPPLY       |
| 15 | LO-25, SUMP SUPPLY/PURIFIER RTN-STBD ENG | 35 | LO-33, SUMP DISCH-BOW ENG     |
| 16 | LO-23, PRE-LUBE RETURN-STBD ENG          | 36 | HAND SUPPLY                   |
| 17 | LO-19, SUMP SUCT-STBD ENG                | 37 | LO-32, SUMP SUCT-BOW ENG      |
| 18 | LO-31, SUMP DISCH-SSDG                   | 38 | LO-37, DIRTY OIL PUMP DISCH   |
| 19 | LO-29, SUMP SUCT-SSDG                    | 39 | LO-36, DIRTY OIL PUMP SUCT    |
| 20 | LO-27, SUMP SUPPLY                       |    |                               |

FIGURE 2-165. Lube Oil Purification and Transfer Piping System (Sheet 8 of 8).

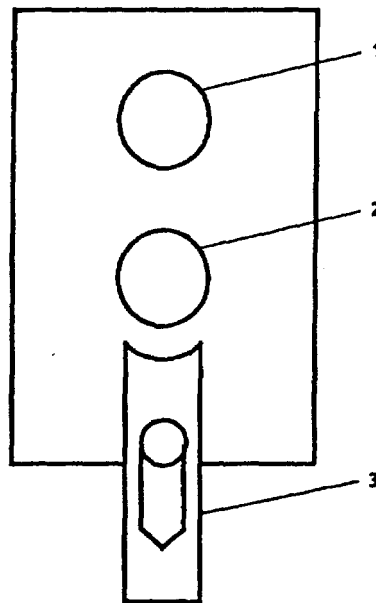
**LEGEND**

- 1. **START**
- 2. **STOP**
- 3. **LOCK**

FIGURE 2-166. TYPE-I Motor Switch.

- (e) Check the output by pening the top inspection cover. Close top inspection cover.
  - (f) Slowly open LO-11, PURIFIER SUCTION (32) until glass bowl is approximately 1/2 full.
  - (g) Allow L.O. Purifier to purify oil for 4 hours per engine.
- (3) L.O. Purifier and L.O. Purifier Preheater Shutdown.
- (a) On Lube Oil Heater Switch (FIGURE 2-164) press STOP pushbutton (2) and set LOCK (3) by sliding LOCK (3) upward.
  - (b) Close LO-11, PURIFIER SUCTION (32, FIGURE 2-167).
  - (c) Wait 1 minute.
  - (d) On L.O. Purifier TYPE-I Motor Switch (FIGURE 2-166) press STOP pushbutton (2) and set LOCK (3) by sliding LOCK (3) upward.
  - (e) Close all valves in the Lube Oil Purification and Transfer piping system (FIGURE 2-167).
  - (f) On Auxiliary Machinery Motor Control Center (FIGURE 2-167) set L.O. PURIFIER circuit breaker and L.O. PURIFIER HEATER circuit breaker (2) to OFF position.
- (1)

- b. Transfer of lube oil from main engines, reduction gears, ship service diesel generator (SSDG) engines and bowthruster engine to dirty oil tank.

**CAUTION**

Never operate an engine without lubricating oil in sump. This will cause serious internal damage to the engine.

- (1) Transfer dirty oil from STBD MAIN ENG to dirty oil tank
  - (a) Close all valves in the Lube Oil Purification and Transfer Piping System (FIGURE 2-165).
  - (b) Open LO-19, SUMP SUCT-STBD ENG (17).
  - (c) Open LO-21, MN ENG SUMP DISCH (21).
  - (d) Operate STBD MN ENG SUMP PUMP in clockwise direction until STBD MAIN ENG oil sump pump loses suction.
  - (e) Close LO-19, SUMP SUCT-STBD ENG (17) and LO-21, MN ENG SUMP DISCH (21).
- (2) Transfer dirty oil from STBD reduction gear to dirty oil tank
  - (a) Close all valves in Lube Oil Purification and Transfer Piping System (FIGURE 2-165).
  - (b) Open LO-17, RDCN GEAR SUCT-STBD (22).
  - (c) Open LO-21, MN ENG SUMP DISCH (21).
  - (d) Operate STBD MN ENG SUMP PUMP in clockwise direction until STBD reduction gear pump loses suction.
  - (e) Close LO-17, RDCN GEAR SUCT-STBD (22) and LO-21, MN ENG SUMP DISCH (21).
- (3) Transfer dirty oil from PORT MAIN ENG to dirty oil tank
  - (a) Close all valves in Lube Oil Purification and Transfer Piping System (FIGURE 2-165).
  - (b) Open LO-18, SUMP SUCT-PORT ENG (12).
  - (c) Open LO-20, MN ENG SUMP DISCH (13).
  - (d) Operate MN ENG SUM PUMP in a clockwise direction until PORT MAIN ENG oil sump pump loses suction.
  - (e) Close LO-18, SUMP SUCT-PORT ENG (12) and LO-20, MN ENG SUMP.DISCH (13).
- (4) Transfer dirty oil from port reduction gear to dirty oil tank
  - (a) Close all valves in the Lube Oil Purification and Transfer Piping System (FIGURE 2-165).

- (b) Open LO-16, RDCN GEAR SUCT PORT (4).
  - (c) Open LO-20, MN ENG SUMP DISCH (13).
  - (d) Operate PORT MN ENG SUMP PUMP in clockwise direction until port reduction gear pump loses suction.
  - (e) Close LO-16, RDCN GEAR SUCT PORT (4) and LO-20, MN ENG SUMP DISCH (13).
- (5) Transfer dirty oil from SSDG #1 to dirty oil tank.
- (a) Close all valves in Lube Oil Purification and Transfer Piping System (FIGURE 2-165).
  - (b) Open LO-31, SUMP DISCH-SSDG (18).
  - (c) Open LO-29, SUMP SUCT-SSDG (19).
  - (d) Operate SSDG #1 SUMP PUMP in clockwise direction until SSDG #1 oil sump pump loses suction.
  - (e) Close LO-31, SUMP DISCH-SSDG (18) and LO-29, SUMP SUCT-SSDG (19).
- (6) Transfer dirty oil from SSDG #2 to dirty oil tank.
- (a) Close all valves in Lube Oil Purification and Transfer Piping System (FIGURE 2-165).
  - (b) Open LO-30, SUMP DISCH-SSDG (9).
  - (c) Open LO-28, SUMP SUCT-SSDG (8).
  - (d) Operate SSDG #2 SUMP PUMP in clockwise direction until SSDG #2 loses suction.
  - (e) Close LO-30, SUMP DISCH-SSDG (9) and LO-28, SUMP SUCT-SSDG (8).
- (7) Transfer dirty oil from Bowthruster Engine to dirty oil tank
- (a) Close all valves in Lube Oil Purification and Transfer Piping System (FIGURE 2-165).
  - (b) Open LO-33, SUMP DISCH-BOW ENG (35).
  - (c) Open LO-32, SUMP SUCT-BOW ENG (37).
  - (d) Operate BOW ENG SUMP PUMP in clockwise direction until oil sump pump loses suction.
  - (e) Close LO-33, SUMP DISCH-BOW ENG (35) and LO-32, SUMP SUCT-BOW ENG (37).

- (8) Transfer oil from lube oil storage tank to Main Engine Sumps and SSDG Engine Sumps.
- (a) Close all valves in Lube Oil Purification and Transfer Piping System (FIGURE 2-165).
  - (b) To use HAND PUMP NO. 1, open LO-1, STORAGE TK SUPPLY (34), and LO-3, R HAND PUMP NO. 1 DISCH (33).
  - (c) To use HAND PUMP NO. 2, open LO-2, STORAGE TK SUPPLY (1), and LO-4, HAND PUMP NO. 2 DISCH (2).
  - (d) To transfer lube oil to STBD MAIN ENG, open LO-25, SUMP SUPPLY/PURIFIER RTN STBD ENG (15).
  - (e) To transfer lube oil to PORT MAIN ENG. open LO-24, SUMP SUPPLY/PURIFIER RTN PORT ENG (6).
  - (f) To transfer lube oil to SSDG #1, open LO-27, SUMP SUPPLY (20).
  - (g) To transfer lube oil to SSDG #2, open LO-26, SUMP SUPPLY (7).
  - (h) When engine has been selected and correct valve alignment made, operate hand pump in a clockwise direction, fill the selected engine sump to full mark on engine dipstick.
  - (i) Close all valves in Lube Oil Purification and Transfer Piping System.
- (9) Discharge oil from dirty oil tank.
- (a) Close all valves in Lube Oil Purification and Transfer Piping System.
  - (b) Open LO-34, DIRTY OIL TANK SUCTION (11).
  - (c) Open LO-37, DIRTY OIL PUMP DISCH (38).
  - (d) Open LO-36, DIRTY OIL PUMP SUCT (39).

**NOTE**

Next higher level of maintenance will install IOPP flange.

- (e) If dirty oil is to be discharged on the starboard side, connect discharge hose to STBD dirty oil deck connection, open STBD DIRTY OIL DISCH.
- (f) If dirty oil is to be discharged on the port side, connect discharge hose to port dirty oil deck connection, open PORT DIRTY OIL DISCH.
- (g) On Auxiliary Motor Control Center (FIGURE 2-163), set DIRTY L.O. PUMP P205-12 circuit breaker (3) to ON position.
- (h) On Dirty Oil Discharge Pump TYPE-I Motor Switch (FIGURE 2-166) release LOCK (3) by sliding downward and press START pushbutton (1).

- (i) Observe tank level indicator.
  - (j) When dirty oil tank is empty, press STOP pushbutton (2) and lock in.
  - (k) Close all valves in Lube Oil Purification and Transfer Piping System.
  - (l) Disconnect discharge hose from dirty oil discharge deck connection.
  - (m) Next higher level of maintenance will disconnect IOPP flange.
- (10) Discharge sludge from sludge tank.
- (a) Close all valves in Lube Oil Purification and Transfer Piping System.
  - (b) Open LO-35, SLUDGE TK SUCT (10).
  - (c) Open LO-36, DIRTY OIL PUMP SUCT (39).
  - (d) Open LO-37, DIRTY OIL PUMP DISCH (38).
  - (e) If sludge is to be discharged on the starboard side, connect discharge hose to STBD dirty oil deck connection, then open STBD DIRTY OIL DISCH.

**NOTE**

Next higher level of maintenance will install IOPP flange.

- (f) If dirty oil is to be discharged on the port side, connect discharge hose to port dirty oil deck connection, then open PORT DIRTY OIL DISCH.
  - (g) On Auxiliary Motor Control Center (FIGURE 2-163), set P205-12 circuit breaker (3) to ON position.
  - (h) On Dirty Oil Discharge Pump TYPE-I Motor Switch (FIGURE 2-166), release LOCK (3) by sliding downward and press START pushbutton (1).
  - (i) When pump loses suction, press STOP pushbutton (2).
  - (j) Close all valves in Lube Oil Purification and Transfer Piping System.
  - (k) Disconnect discharge hose from DIRTY OIL DISCHARGE DECK CONNECTION.
- (11) Transfer oil from lube oil storage tank manually to bowthruster engine
- (a) Close all valves in Lube Oil Purification and Transfer Piping System (FIGURE 2-165).
  - (b) To use HAND PUMP NO. 1, open LO-1, STORAGE TK SUPPLY (34) and LO-3, HAND PUMP NO. 1 DISCH (33).
  - (c) To use HAND PUMP NO. 2, open LO-2, STORAGE TK SUPPLY (1) and LO-4, HAND PUMP NO. 2 DISCH (2).

- (d) Obtain a clean container to carry oil forward to Bowthruster Engine. Place container under LO-5, HAND SUPPLY (3).
- (e) Open LO-5, HAND SUPPLY (3).
- (f) Operate HAND PUMP in a clockwise direction until container is filled to desired level.
- (g) Close all valves in Lube Oil Purification and Transfer Piping System.
- (h) For filling instructions at Bowthruster Engine, see LO 55-1905-233-12.

2-18. **Fuel Oil Filter, Transfer, and Supply Piping System.**

a. Fueling Operation (FIGURE 2-167).

**WARNING**

- Fueling operations present a serious fire hazard. Ensure NO SMOKING signs are placed at appropriate locations throughout the LCU and/or decks. Make announcements through public address system that fueling operations are in progress. Take other precautions as required by U.S. Army regulations.
- Static electricity can cause a spark when connecting hose from fuel source to LCU. Ensure all grounding connections are made prior to connecting fuel hose.
- The wake of passing watercraft can cause the LCU to move sufficiently to part fuel hose. Ensure that the BRAVO flag is hoisted by day and a RED LIGHT is lit by night to alert passing watercraft to pass with minimum wake action.

**CAUTION**

Prior to starting defueling operation, ensure drip pans are in place at each connection and that scuppers are plugged to prevent accidental spillage from flowing into navigable waters.

- (1) Open FO-4, SUPPLY TO FO SUPPLY MANF (2).
- (2) Open FO-3, ISLN-FILL/DISCH STATIONS (1).
- (3) If fuel is to be taken on port side, open FO-1, FUEL OIL FILL/DISCH (45), connect fuel hose to PORT FUEL OIL FILL/DISCH.
- (4) If fuel is to be taken on starboard side, open FO-2, FUEL OIL/FILL DISCH (46), connect fueling hose to STBD FUEL OIL FILL/DISCH.
- (5) To pump fuel oil to a selected tank, the following alignment will be used:
  - (a) F-3P tank, open FO-6, SUPPLY TO TK F-3P (58).



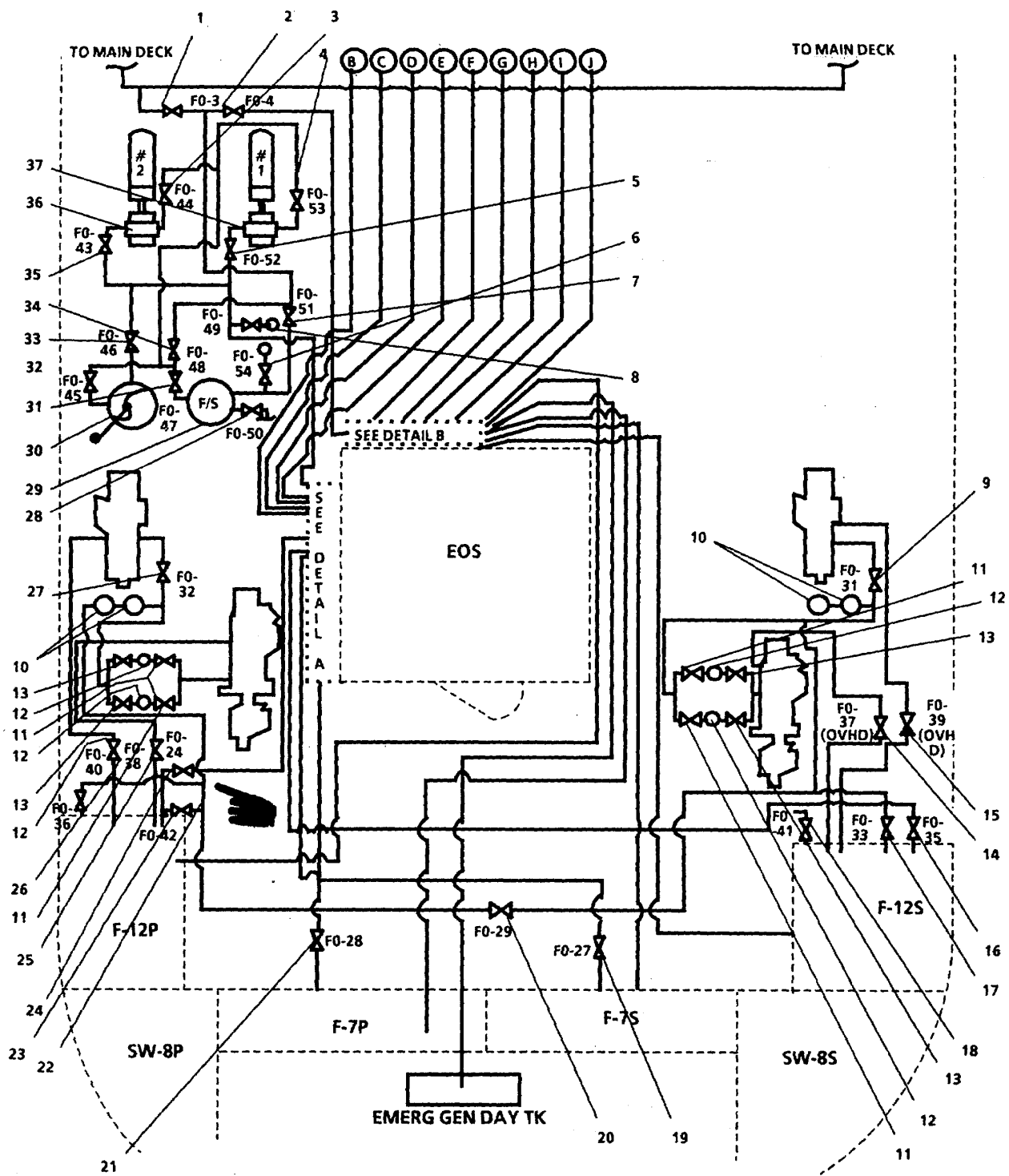

FIGURE 2-167. Fuel Oil Filter, Transfer, and Supply Piping System (Sheet 1 of 6).

Change 1 2-472

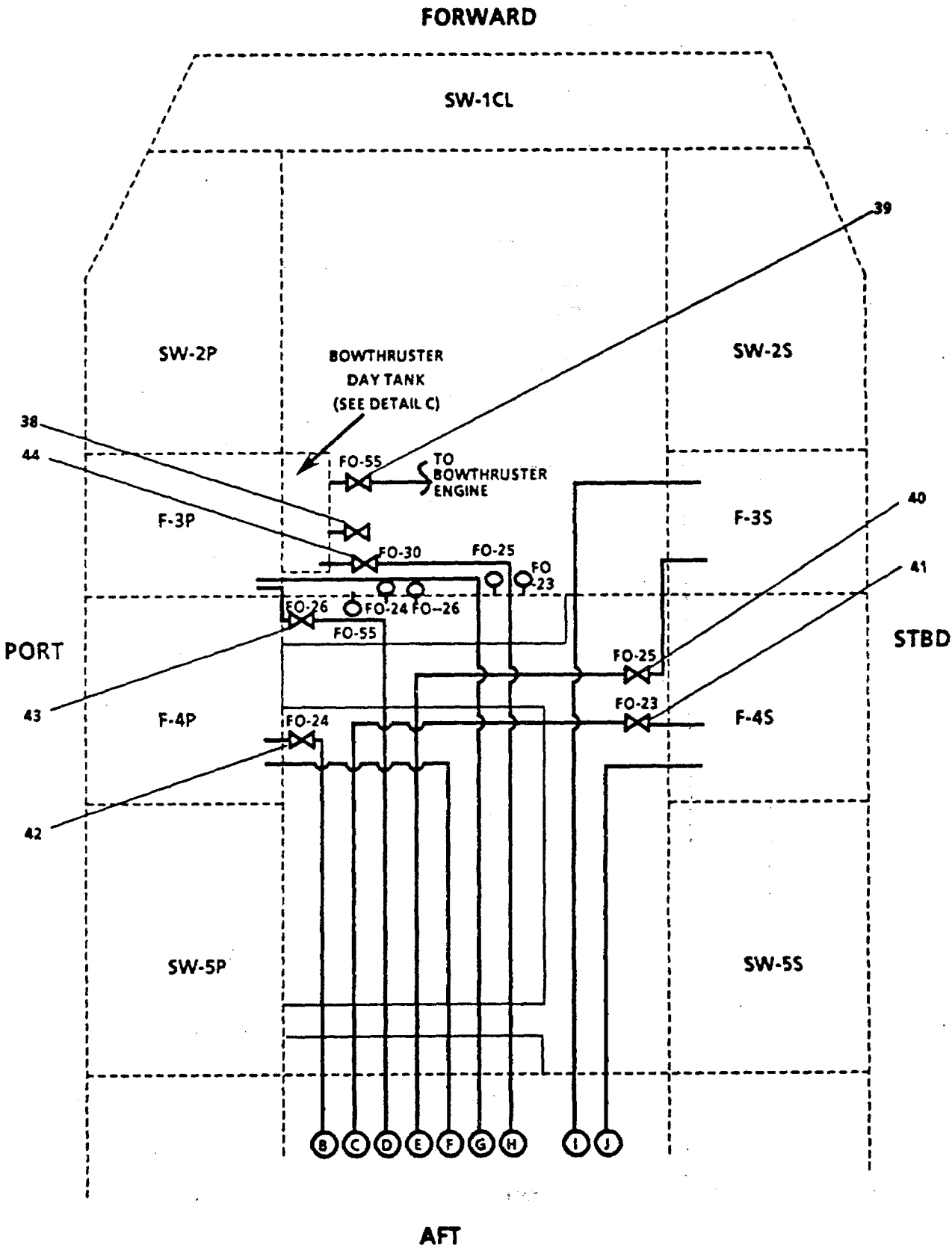

FIGURE 2-167. Fuel Oil Filter, Transfer, and Supply Piping System (Sheet 2 of 6).

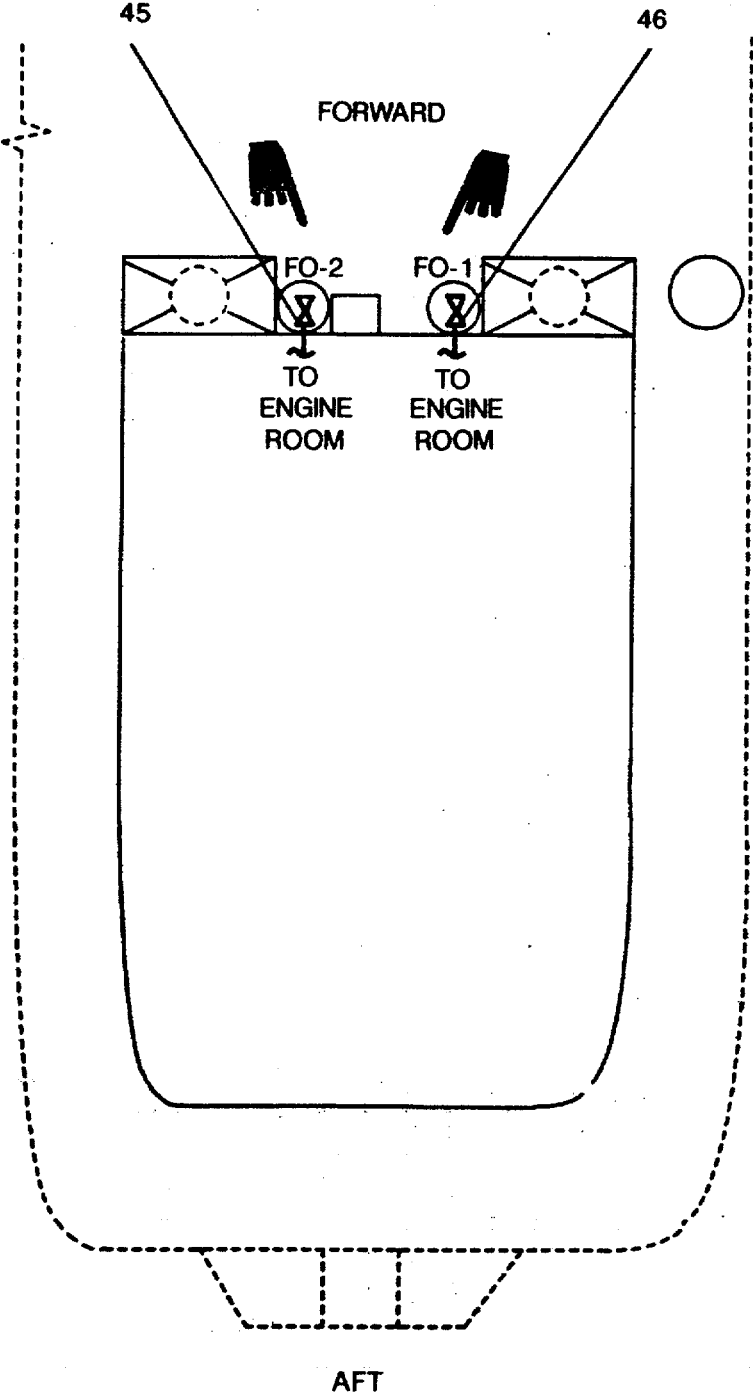
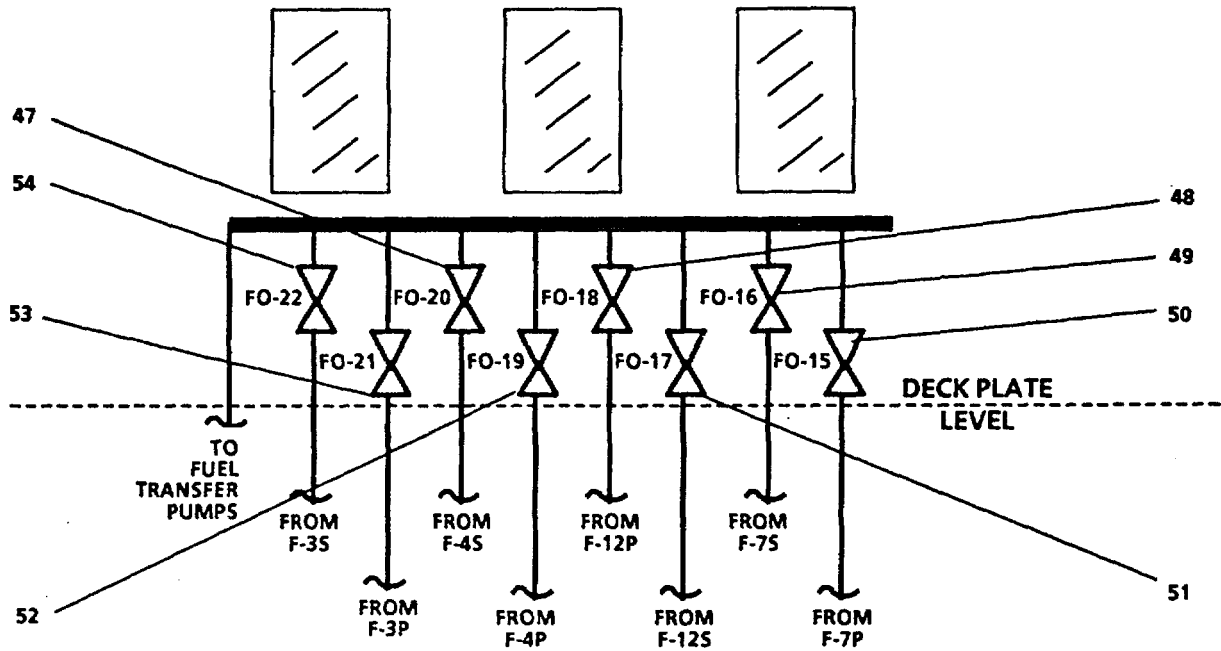

FIGURE 2-167. Fuel Oil Filter, Transfer, and Supply Piping System (Sheet 3 of 6).

Change 2 2-474

**DETAIL A  
PORT EXTERIOR BULKHEAD  
OF EOS (FORWARD)**



**DETAIL B  
FORWARD EXTERIOR BULKHEAD  
OF EOS (PORT)**

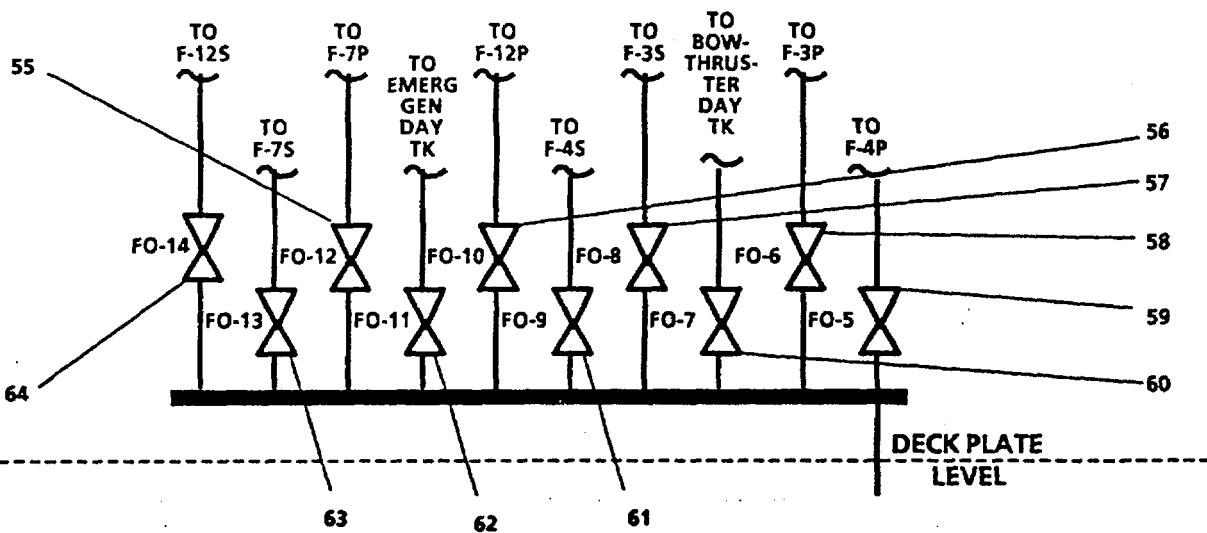

FIGURE 2-167. Fuel Oil Filter, Transfer, and Supply Piping System (Sheet 4 of 6).

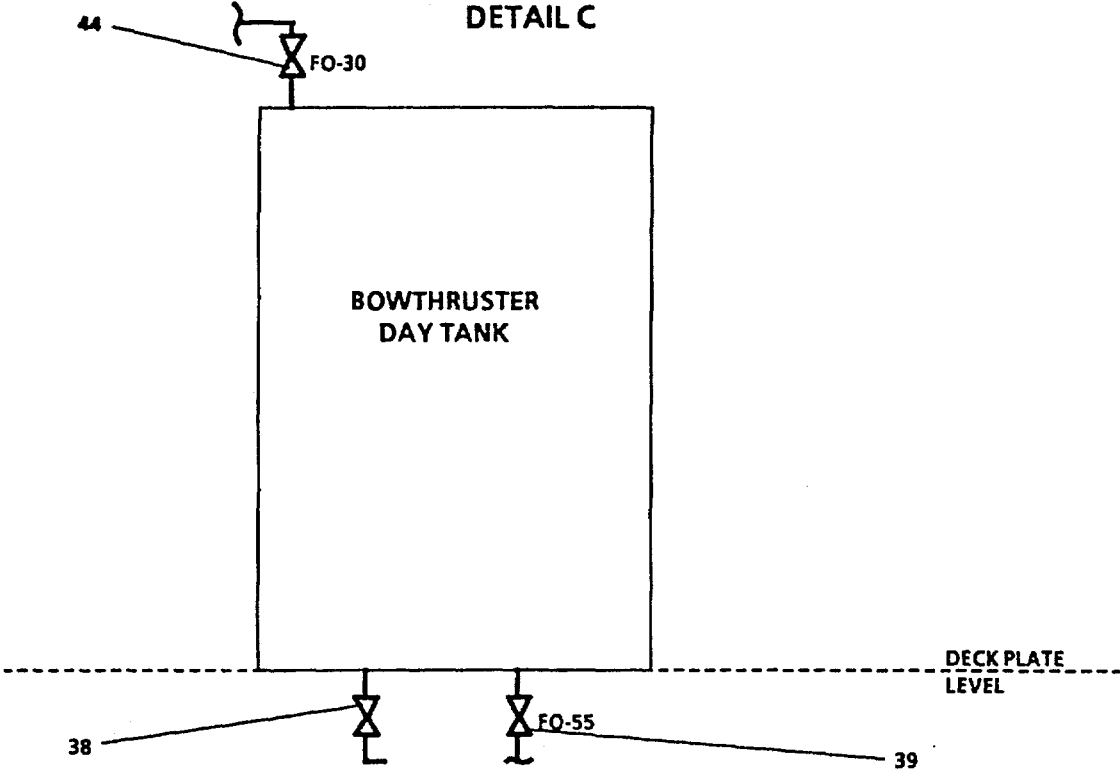

FIGURE 2-167. Fuel Oil Filter, Transfer, and Supply Piping System (Sheet 5 of 6).

**LEGEND**

1. FO-3, ISLN-FILL/DISCH STATIONS
2. FO-4, SUPPY TO FO SUPPLY MANF
3. FO-44, DISCH -NO. 2 XFR PUMP
4. FO-53, DISCH- NO. 1 XFR PUMP
5. FO-52, SUCT-NO. 1 XFR PUMP
6. FO-54, PUMP DISCH PRESS GAGE
7. FO-51, FILTER/SEPARATOR OUTLET
8. FO-49, PUMP SUCT PRESS GAGE
9. FO-31, SUPPLY TO STRDSSDG
10. SSDG FUEL FILTERS
11. MN ENG FILTER DISCH VALVE
12. MN ENG FILTER
13. MN ENG FILTER INLET VALVE
14. FO-37, RETURN FR STBD MN ENG TO DAY TK F-12S
15. FO-39, RETURN FR STBD SSDG TO DAY TK F-12S
16. FO-35, SUCT FR DAY TK F-12S
17. FO-33, DAY TK F-125 SUPPLY TO STBD MN ENG & SSDG
18. FO-41, DRAIN FR DAY TK F-12S
19. FO-27, SUCT FR TK F-7S
20. FO-29, CROSS CONN - DAY TKS
21. FO-28, SUCT FR TK F-7P
22. FO-36, DAY TK F-12P SUPPLY TO PORT MN ENG & SSDG
23. FO-42, DRAIN FR DAY TK F-12P
24. FO-34, SUCT FR DAY TK F-12P
25. FO-38, RETURN FR PORT MN ENG TO DAY TK F-12P
26. FO-40, RETURN FR PORT SSDG TO DAY TK F-12P
27. FO-32, SUPPLY TO PORT SSDG
28. FO-50, DRAIN TO SLUDGE TK
29. FUEL FILTER/COALESCER
30. FUEL TRANSFER HAND PUMP
31. FO-47, FILTER/SEPARATOR INLET
32. FO-45, HAND PUMP DISCH
33. FO-46, HAND PUMP SUCT
34. FO-48, BY-PASS FILTER/SEPARATOR
35. FO-43, SUCT-NO. 2 XFR PUMP
36. NO. 2 XFR PUMP
37. NO. 1 XFR PUMP
38. BOW THRUSTER DAY TK DRAIN
39. FO-55, SUPPLY TO BOW THRUSTER ENGINE
40. FO-25, SUCT FR TK F-3S
41. FO-23, SUCT FR TK F-4S
42. FO-24, SUCT FR TK F-4P
43. FO-26, SUCT FR TK F-3P
44. FO-30, SUPPLY TO BOW THRUSTER DAY TK
45. FO-1, FUEL OIL FILL/DISCH
46. FO-2, FUEL OIL FILUDISCH
47. FO-20, SUCT FR TK F-4S
48. FO-18, SUCT FR TK F-12P
49. FO-16, SUCT FR TK F-7S
50. FO-15, SUCT FR TK F-7P
51. FO-17, SUCT FR TK F-12S
52. FO-19, SUCT FR TK F-4P
53. FO-21, SUCT FR TK F-3P
54. FO-22, SUCT FR TK F-3S
55. FO-12, SUPPLY TO TK F-7P
56. FO-10, SUPPLY TO DAY TK F-1 2P
57. FO-8, SUPPLY TO TK F-3S
58. FO-6, SUPPLY TO TK F-3P
59. FO-5, SUPPLY TO TK F-4P
60. FO-7, SUPPLY TO BOW THRUSTER DAY TK
61. FO-9, SUPPLY TO TK F-4S
62. FO-11, SUPPY TO EMER GEN DAY TK
63. FO-13, SUPPY TO TKIF-75
64. FO-14, SUPPY TO TK F-12S

FIGURE 2-167. Fuel Oil Filter, Transfer, and Supply Piping System (Sheet 6 of 6).

**NOTE**

When each tank is filled, open next tank valve before closing tank valve of tank that is being filled.

- (b) F-3S tank, open FO-8, SUPPLY TO TK F-3S (57).
  - (c) F-4P tank, open FO-5, SUPPLY TO TK F-4P (59).
  - (d) F-4S tank, open FO-9, SUPPLY TO TK F-4S (61).
  - (e) F-7P tank, open FO-12, SUPPLY TO TK F-7P (55).
  - (f) F-7S tank, open FO-13, SUPPLY TO TK F-7S (63).
  - (g) Turn on tank level indicators, (FIGURE 2-168) by setting POWER switch (1) to ON position.
- (6) When tank has been selected and the proper alignment made, direct the fuel oil supplier to start pumping the fuel oil.

**WARNING**

- During fueling operation, close coordination is required between crew and fuel oil supplier to prevent spills or overfilling tanks.
- **NO SMOKING** is allowed during fueling operation.

- (7) As each tank is filled, close supply valve to that tank.
  - (8) When all fuel oil has been taken aboard, close FO-1, FUEL OIL FILL/DISCH (45, FIGURE 2-167) for port side or FO-2, FUEL OIL FILL/DISCH (46) for starboard side depending on side fuel was taken on.
  - (9) Close FO-3, ISLN-FILL/DISCH STATIONS (1) and FO-4, SUPPLY TO FO SUPPLY MANF (2).
  - (10) Disconnect fueling hose from overboard discharge/fill connection.
- b. Transfer fuel oil between fuel oil tanks.
- (1) To transfer fuel oil using NO 1 XFR PUMP, open FO-52, SUCT-NO. 1 XFR PUMP (5, FIGURE 2-167).
  - (2) Open FO-53, DISCH-NO. 1 XFR PUMP (4).
  - (3) Open FO-4, SUPPLY TO FO SUPPLY MANF (2).
  - (4) Open FO-54, DIST PUMP DISCH PRESS GAGE (6).
  - (5) Open FO-49, PUMP SUCT PRESS GAGE (8).

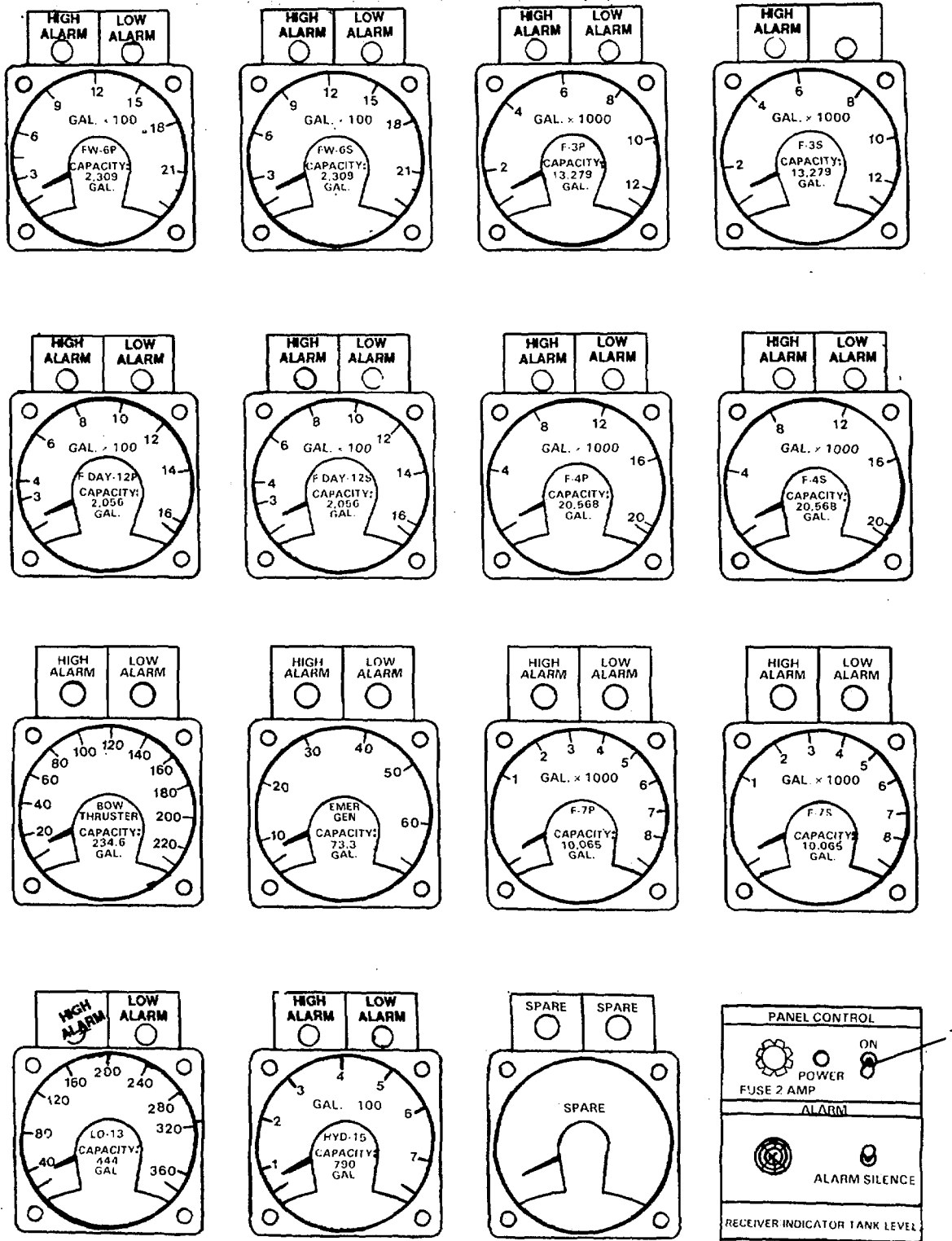
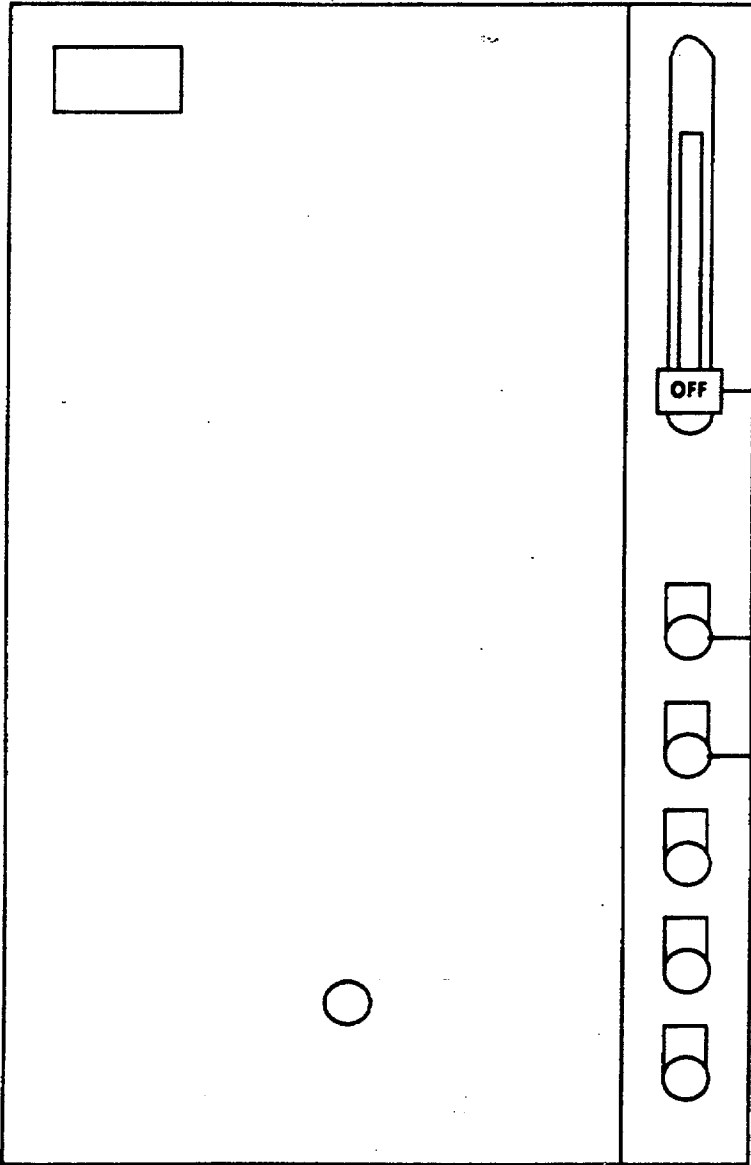

FIGURE 2-168. Tank Level Indicator.



- (6) If the Fuel Filter/Coalescer is to be used, open FO-47, FILTER/SEPARATOR INLET (31) and FO-51, FILTER/SEPARATOR OUTLET (7).-
- (7) If the Fuel Filter/Coalescer is NOT to be used, open FO-48, BY-PASS FILTER/SEPARATOR (34).
- (8) Align tank that fuel is to be pumped from as follows:
  - (a) F-3P, open FO-21 and FO-26, SUCT FM TK F-3P (53 and 43).
  - (b) F-3S, open FO-22 and FO-25, SUCT FM TK F-3S (54 and 40).
  - (c) F-4P, open FO-19 and FO-24, SUCT FM TK F-4P (52 and 42).
  - (d) F-4S, open FO-20 and FO-23, SUCT FM TK F-4S (47 and 41).
  - (e) F-7P, open FO-15 and FO-28, SUCT FM TK F-7P (50 and 21).
  - (f) F-7S, open FO-16 and FO-27, SUCT FM TK F-7S (49 and 19).
  - (g) F-12P, open FO-18 and FO-34, SUCT FR DAY TK F-12P (48 and 24).
  - (h) F-12S, open FO-17 and FO-35, SUCT FR DAY TK F-12S (51 and 16).
- (9) Align tank that is to receive fuel as follows:
  - (a) F-3P, open FO-6, SUPPLY TO TK F-3P (58).
  - (b) F-3S, open FO-8, SUPPLY TO TK F-3S (57).
  - (c) F-4P, open FO-5, SUPPLY TO TK F-4P (59).
  - (d) F-4S, open FO-9, SUPPLY TO TK F-4S (61).
  - (e) F-7P, open FO-12, SUPPLY TO TK F-7P (55).
  - (f) F-7S, open FO-13, SUPPLY TO TK F-7S (63).
  - (g) Bowthruster, day tank, open FO-7 and FO-30, SUPPLY TO BOWTHRUSTER DAY TK (60 and 44).
  - (h) Emergency -generator day tank, open FO-II, SUPPLY TO EMER GEN DAY TK (62).
  - (i) F-12P, open FO-10, SUPPLY TO DAY TK F-12P (56).
  - (j) F-12S, open FO-14, SUPPLY TO DAY TK F-12S (64).
  - (k) Turn on tank level indicators, (FIGURE 2-168) by setting POWER switch (1) to ON position.
  - (l) On Fuel Transfer Pump Motor Controllers (FIGURE 2-169), set circuit breaker (1) to ON position.



- LEGEND**
- 1. **CIRCUIT BREAKER HANDLE**
  - 2. **START PUSH BUTTON**
  - 3. **STOP PUSH BUTTON**

*FIGURE 2-169. Fuel Transfer Pump Motor Controller.*

- (10) Operate No. 1 XFR PUMP by pressing START Push Button (1, FIGURE 2-170), and observe tank level indicator (FIGURE 2-168) until desired amount of fuel has been transferred. Press STOP pushbutton (2, FIGURE 2-170).
- (11) Close suction valves of tank that fuel was pumped from.
- (12) Close supply valve of tank that fuel was pumped to.
- (13) To transfer fuel oil using NO. 2 XFR PUMP, open FO-43, SUCTION VALVE FOR #2 FUEL OIL TRANSFER PUMP (35, FIGURE 2-167).
- (14) Open FO-44, DISCH-NO. 2 XFR PUMP (3).
- (15) Follow steps 2-18b(3) through 2-18b(9Xk).
- (16) Operate NO. 2 XFR PUMP by pressing START Push Button (1, FIGURE 2-170), and observe tank level indicator (FIGURE 2-168), until desired amount of fuel has been transferred. Press STOP Push Button (2, FIGURE 2-170).
- (17) Close suction valves of tank that fuel was pumped from.

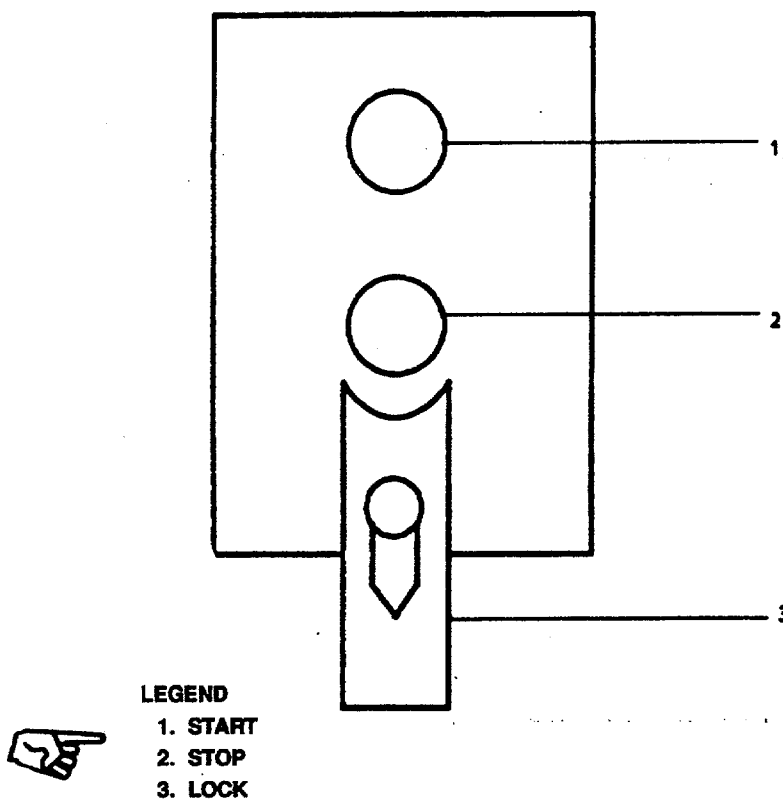

FIGURE 2-170. Fuel Oil Transfer Switch.

(18) Close supply valve of tank that fuel was pumped to.

c. Defueling Operation (FIGURE 2-167).

**WARNING**

- Defueling operations present a serious fire hazard. Ensure NO SMOKING signs are placed at appropriate locations throughout the LCU and/or decks. Make announcements through public address system that defueling operations are in progress. Take other precautions as required by U.S. Army regulations.
- Static electricity can cause a spark when connecting hose from LCU to fuel storage facility. Ensure all grounding connections are made prior to connecting fuel hose.
- The wake of passing watercraft can cause the LCU to move sufficiently to part fuel hose. Ensure that the BRAVO flag is hoisted by day and a RED LIGHT is lit by night to alert passing watercraft to pass with minimum wake action.

**CAUTION**

Prior to starting defueling operation, ensure drip pans are in place at each connection and that scuppers are plugged to prevent accidental spillage from flowing into navigable waters.

- (1) To defuel from the PORT side, connect hose to PORT FUEL OIL FILL/DISCH, open FO-1, FUEL OIL FILL/DISCH (45).
- (2) To defuel from- the STBD side, connect hose to STBD FUEL OIL FILL/DISCH, open FO-2 FUEL OIL FILL/DISCH (46).
- (3) Open FO-3, ISLN-FILL/DISCH STATIONS (1).
- (4) Open FO-53, DISCH-NO. 1 XFR PUMP (4).
- (5) Open FO-44, DISCH-NO. 2 XFR PUMP (3).
- (6) Open FO-52, SUCT-NO. 1 XFR PUMP (5).
- (7) Open FO-43, SUCT-NO. 2 XFR PUMP (35).
- (8) Open FO-54, PUMP DISCH PRESS GAGE (6).
- (9) Open FO-49, PUMP SUCT PRESS GAGE (8).
- (10) Align tank to be drained as follows:
  - (a) F-3P, open FO-26 and FO-21, SUCT FR TK F-3P (43 and 53).

- (b) F-3S, open FO-25 and FO-22, SUCT FR TK F-3S (40 and 54).
- (c) F-4P, open FO-24 and FO-19, SUCT FR TK F-4P (42 and 52)..
- (d) F-4S, open FO-23 and FO-20, SUCT FR TK F-4S (41 and 47).
- (e) F-7P, open FO-28 and FO-15, SUCT FR TK F-7P (21 and 50).
- (f) F-7S, open FO-27 and FO-16, SUCT FR TK F-7S (19 and 49).
- (g) F-12P, open FO-34 and FO-18, SUCT FR DAY TK F-12P (24 and 48).
- (h) F-12S, open FO-35 and FO-17, SUCT FR DAY TK F-12S (16 and 51).
- (i) Operate NO. 1 XFR PUMP and NO. 2 XFR PUMP by pressing START Push Button (1, FIGURE 2-170) on TYPE -I Motor Switches, and observe tank level indicator until fuel has been removed. Press STOP Push Button (2).

(11) Close all valves in Fuel Oil Filter, Transfer, and Supply Piping System.

(12) Disconnect fueling hose from deck connection.

2-19. Oil-Water Separator Piping System.

**CAUTION**

The Oil Water Separator Piping System may not produce a legally acceptable oil free water effluent if the water contains soap, deter- gents, bilge cleaners, protein-foam, or similar agents. The rated capacity of the system is the maximum flow rate with clean filter elements and 0 psi back pressure.

**CAUTION**

Do not run water having temperature above 130°F (55°C) through the OCA-1A Sensing Module, as high temperatures may affect the accuracy of the PPM reading.

a. System Startup Operation.

- (1) Close all valves in Oil Water Separator Piping System (FIGURE 2-171).
- (2) Open valves OWS-1, BILGE SUCTION (2) and OWS-2, BILGE SUCTION (4).
- (3) Open OWS-5, 1ST STAGE SUCT (21).
- (4) Open OWS-11, 1ST STAGE PRESS GAUGE (7).
- (5) Open OWS-9, 2ND STAGE PRESS GAUGE (11).
- (6) Open OWS-6, DISCH TO SLTTDGE TK (20).
- (7) Open OWS-13, OIL RETURN TO 1ST STAGE (13).

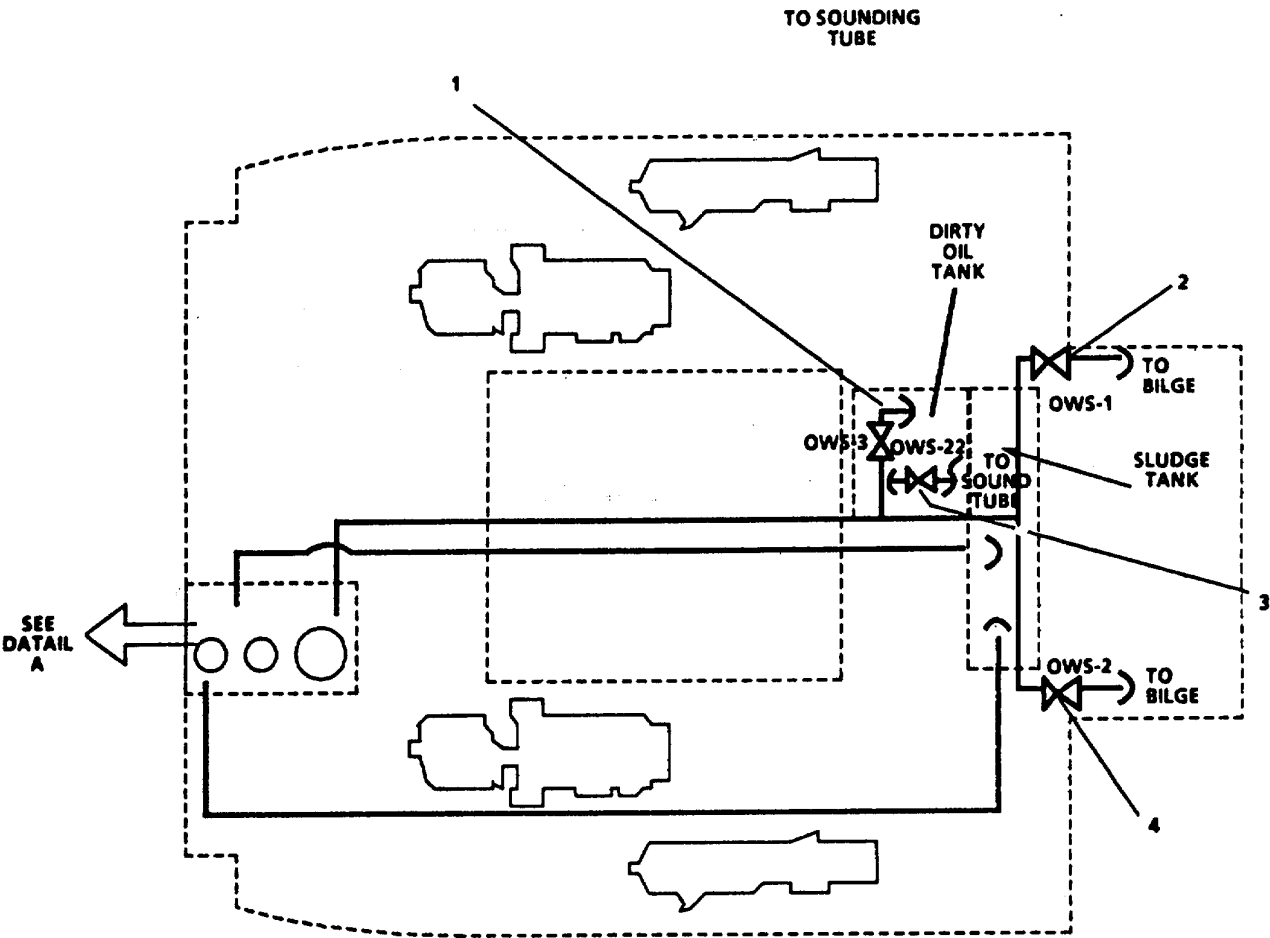

**LEGEND**

- 1. OWS-3, DIRTY OIL TK SUCT
- 2. OWS-1, BILGE SUCTION
- 3. OWS-22, SNDG TUBE DIRTY OIL TK
- 4. OWS-2, BILGE SUCTION

FIGURE 2-171. Oil Water Separator Piping System (Sheet 1 of 5).

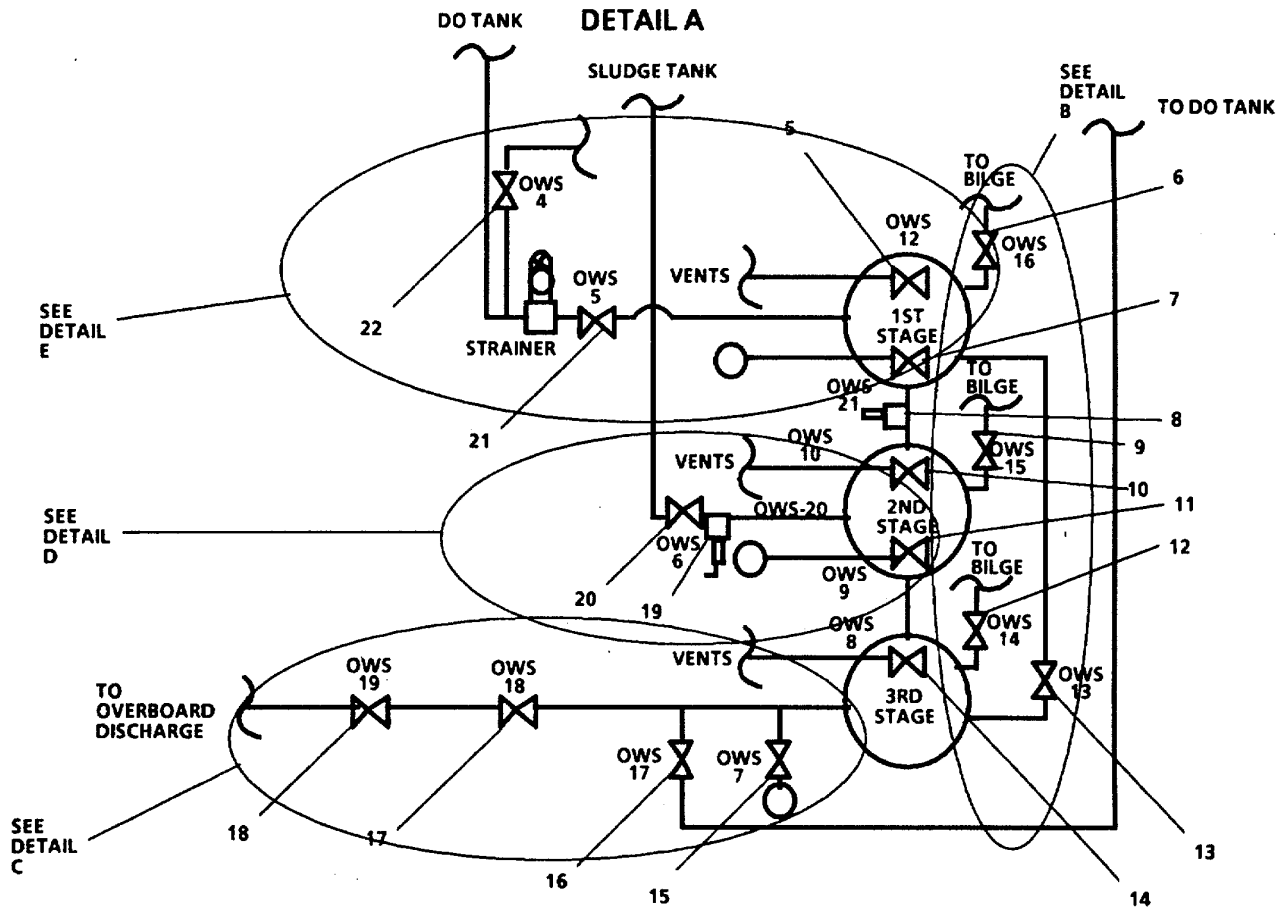

**LEGEND**

- |                                       |  |
|---------------------------------------|--|
| 5. OWS-12, 1ST STAGE VENT             | 15. OWS-7, 3RD STAGE PRESS GAGE        |
| 6. OWS-16, 1ST STAGE DRAIN            | 16. OWS-17, RECIRC TO DIRTY OIL TK     |
| 7. OWS-11, 1ST STAGE PRESS GAGE       | 17. OWS-18, OVBD DISCH                 |
| 8. OWS-21, RELIEF VALVE SET AT 36 PSI | 18. OWS-19, OVBD DISCH                 |
| 9. OWS-15, 2ND STAGE DRAIN            | 19. OWS-20, RELIEF VALVE SET AT 42 PSI |
| 10. OWS-10, 2ND STAGE VENT            | 20. OWS-6, DISCH TO SLUDGE TK          |
| 11. OWS-9, 2ND STAGE PRESS GAGE       | 21. OWS-5, 1ST STAGE SUCT              |
| 12. OWS-14, 3RD STAGE DRAIN           | 22. OWS-4, FRESH WATER MKUP            |
| 13. OWS-13, OIL RETURN TO 1ST STAGE   | 23. OWS-24 PRESSURE GAGE               |
| 14. OWS-8, 3RD STAGE VENT             | 24. OWS-23 PRESSURE GAGE               |

FIGURE 2-171. Oil-Water Separator Piping System (Sheet 2-of 5).

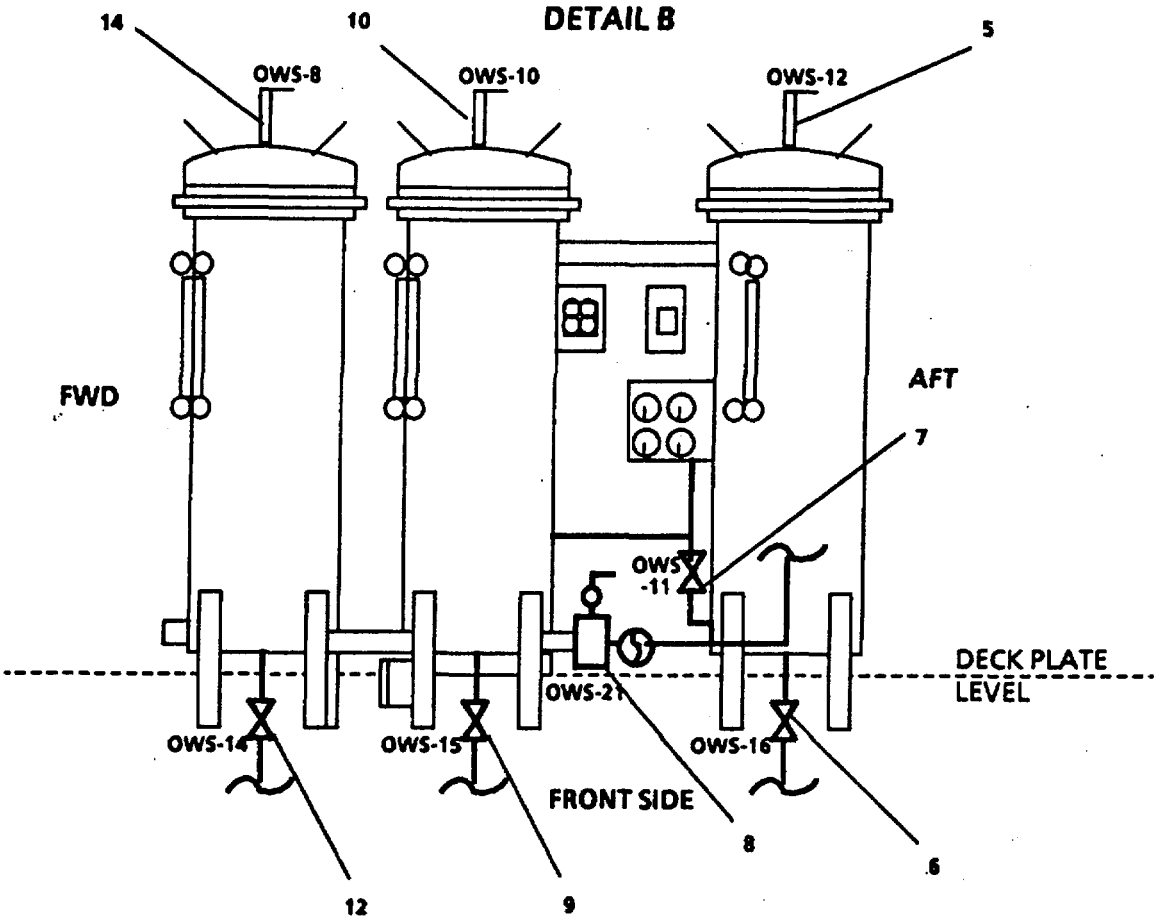

FIGURE 2-171. Oil-Water Separator Piping System (Sheet 3-of 5).



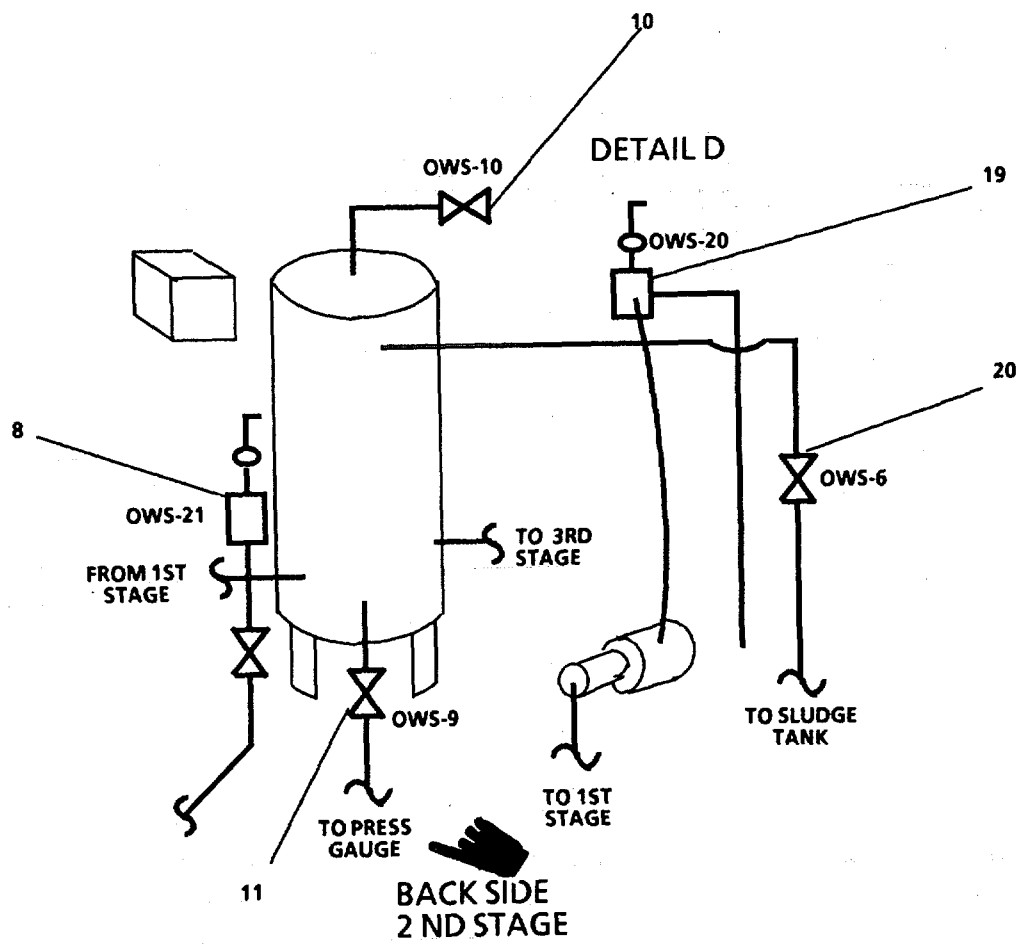
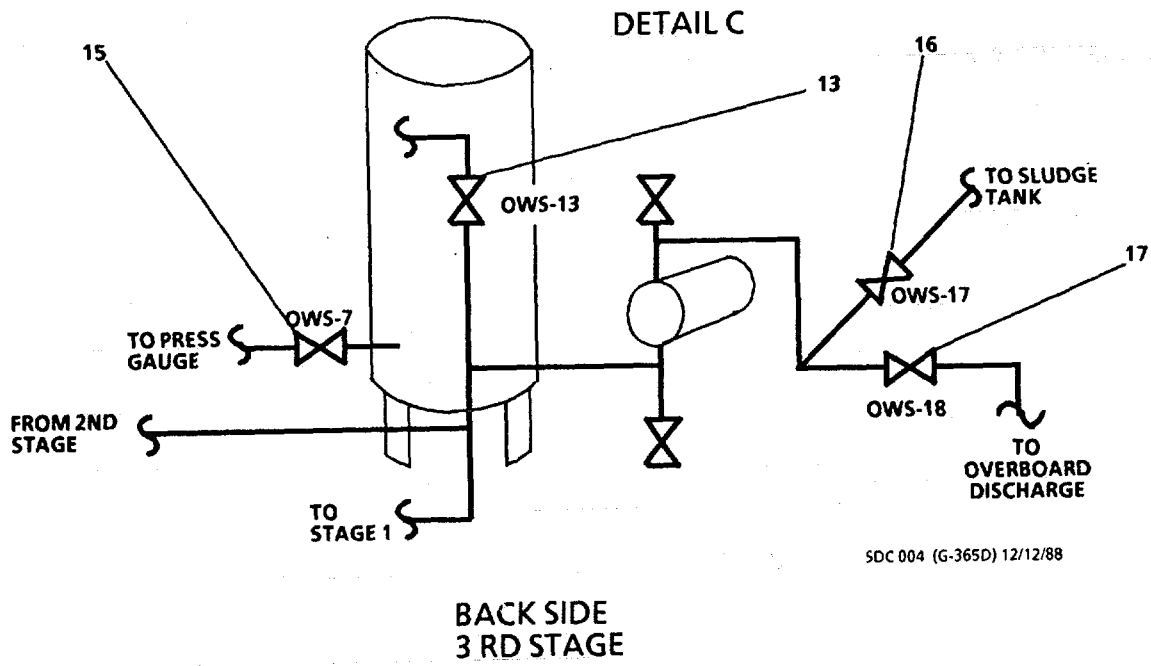

FIGURE 2-171. Oil-Water Separator Piping System (Sheet 4 of 5).

DETAIL E

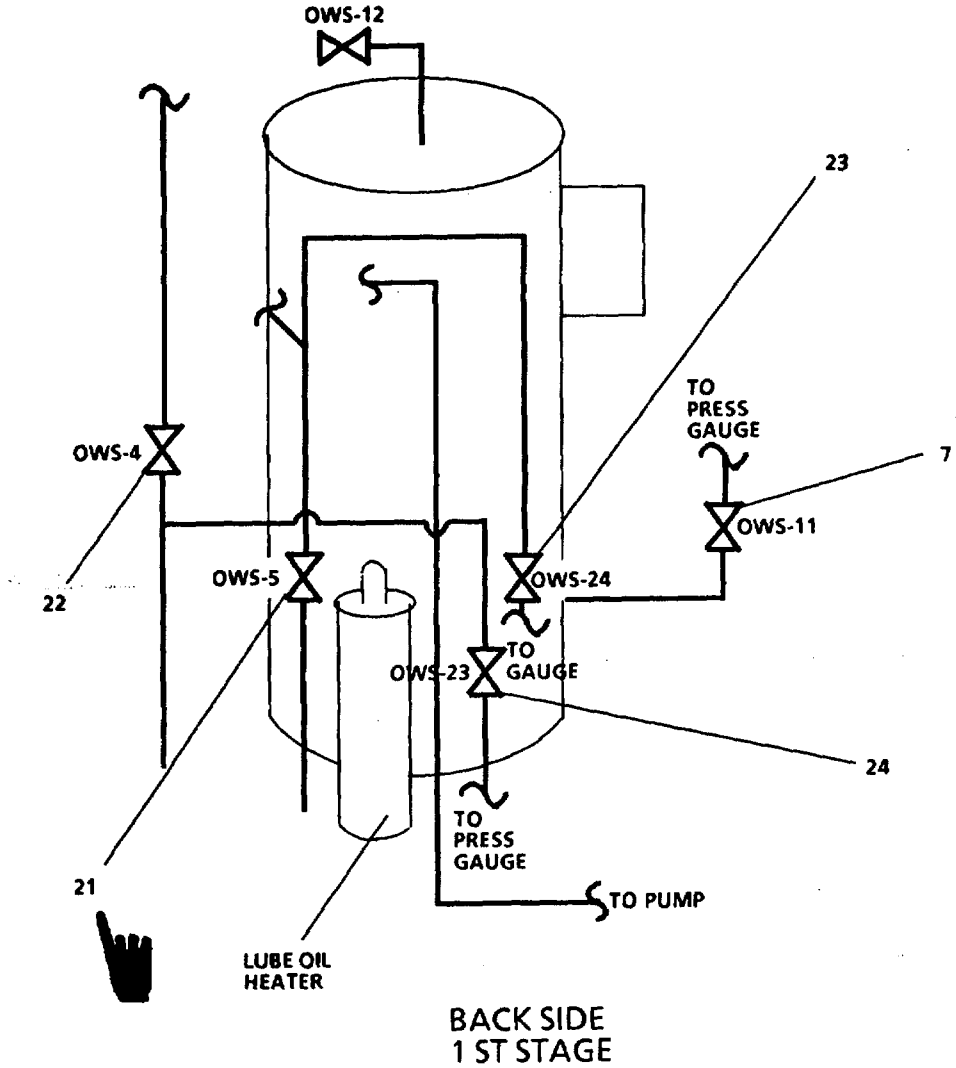

FIGURE 2-171. Oil-Water Separator Piping System (Sheet 5-of 5).

Change 1 2-489

- (8) Open OWS-7, 3RD STAGE PRESS GAUGE (15).
- (9) Open OWS-17, RECIRC TO DIRTY OIL TK (16).
- (10) Open OWS-18 OVBD DISCH (17) and OWS-19, OVBD DISCH (18).
- (11) On Oil Water Separator Control Unit (FIGURE 2-172), set OFF-ON-POWER switch (3) to ON position.
- (12) Set AUTO-MAN-OFF PUMP switch (2) to AUTO position. The PUMP indicator (1) lights when pump is on.

**NOTE**

If water pump fails to start, it is possible that the internal air shutdown float switch in the first stage has tripped due to an accumulation of air in this stage.

- (13) Reset AUTO-MAN-OFF PUMP switch (2) to MAN position.

**NOTE**

This will override the shut down function of the internal float switch and will operate the oil pump to evacuate entrapped air. Leave the pump switch in manual position only for a short time.

- (14) Set AUTO-MAN-OFF PUMP switch (2) to AUTO position when air has been evacuated.
- (15) On Oil Water Separator monitor PRESSURE GAUGE-SECOND STAGE PRESSURE GAUGE- THIRD STAGE INLET and PRESSURE GAUGE-THIRD STAGE OUTLET for differential pressure buildup.

**NOTE**

Differential pressure is the difference in pressure between the input pressure of a stage and the output pressure of that stage. A rapid rise in the differential pressure for the second stage indicates that the filter elements are being blocked by solid contaminants.

- (16) When desired level is reached in bilge, set AUTO-MAN-OFF PUMP switch (2, FIGURE 2-172) to OFF position.

**NOTE**

Unless the system is to be shut down for an indefinite period, DO NOT turn OFF the OFF-ON POWER switch.

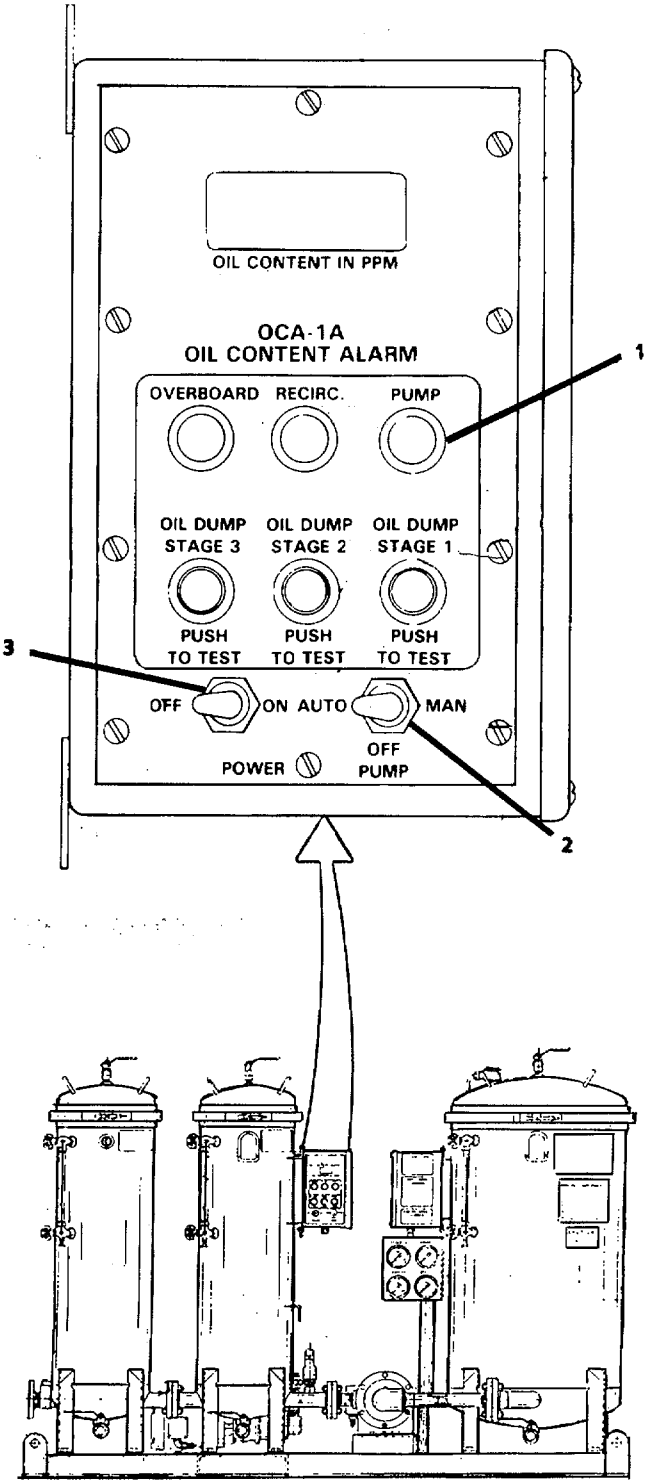

- LEGEND**
- 1. PUMP
  - 2. AUTO-MAN-OFF PUMP
  - 3. OFF-ON-POWER

FIGURE 2-172. Oil-Water Separator Unit.  
2-491

b. System Shutdown Operation.

- (1) Set AUTO-MAN-OFF PUMP switch (2) to OFF position.
- (2) Set OFF-ON-POWER switch (3) to OFF position.

2-20. **Hydraulic Oil Supply Piping System (FIGURE 2-173).****NOTE**

- Two crew members are required to transfer hydraulic oil, one crew member at storage tank, one crew member at compartment. Close coordination is to be maintained by using the LS-519 intercom.
- At each hydraulic supply station a dust cap must be removed and a hose attached to that station's valve.

## a. Open HYD-1, HAND PUMP SUCT-STOR TK (4).

## b. Supply to different stations is as follows:

- (1) Boatswain storeroom, open HYD-4, PWR PACK FILL (5).
- (2) Bowthruster compartment, open HYD-3, PWR PACK FILL (1).
- (3) Steering compartment, open HYD-5, PWR PACK FILL (7), or HYD-6, PWR PACK FILL (6).
- (4) Crew member at storage tank will operate HYD OIL HAND PUMP (3) in a clockwise direction.
- (5) Crew member at supply station will direct the transfer of hydraulic oil, telling the pump operator when power pack tank is full.
- (6) Crew member at pump will close HYD-1, HAND PUMP SUCT-STOR TK (4).
- (7) Crew member at supply station will close the power pack fill valve, remove hose, and replace dust cap.

2-21. **Bow Anchor Windlass, Bow Ramp Winch, and Bow Ramp Operations.**a. Bow Anchor Windlass.**WARNING**

- Before operating windlass, ensure personnel and foreign objects are clear of gypsy, chain, and related components. Moving windlass parts can cause serious personal injury or death.
- High pressure hydraulic systems can cause serious personal injury in the event of equipment failure.
- DO NOT operate hydraulic motor with brake engaged.

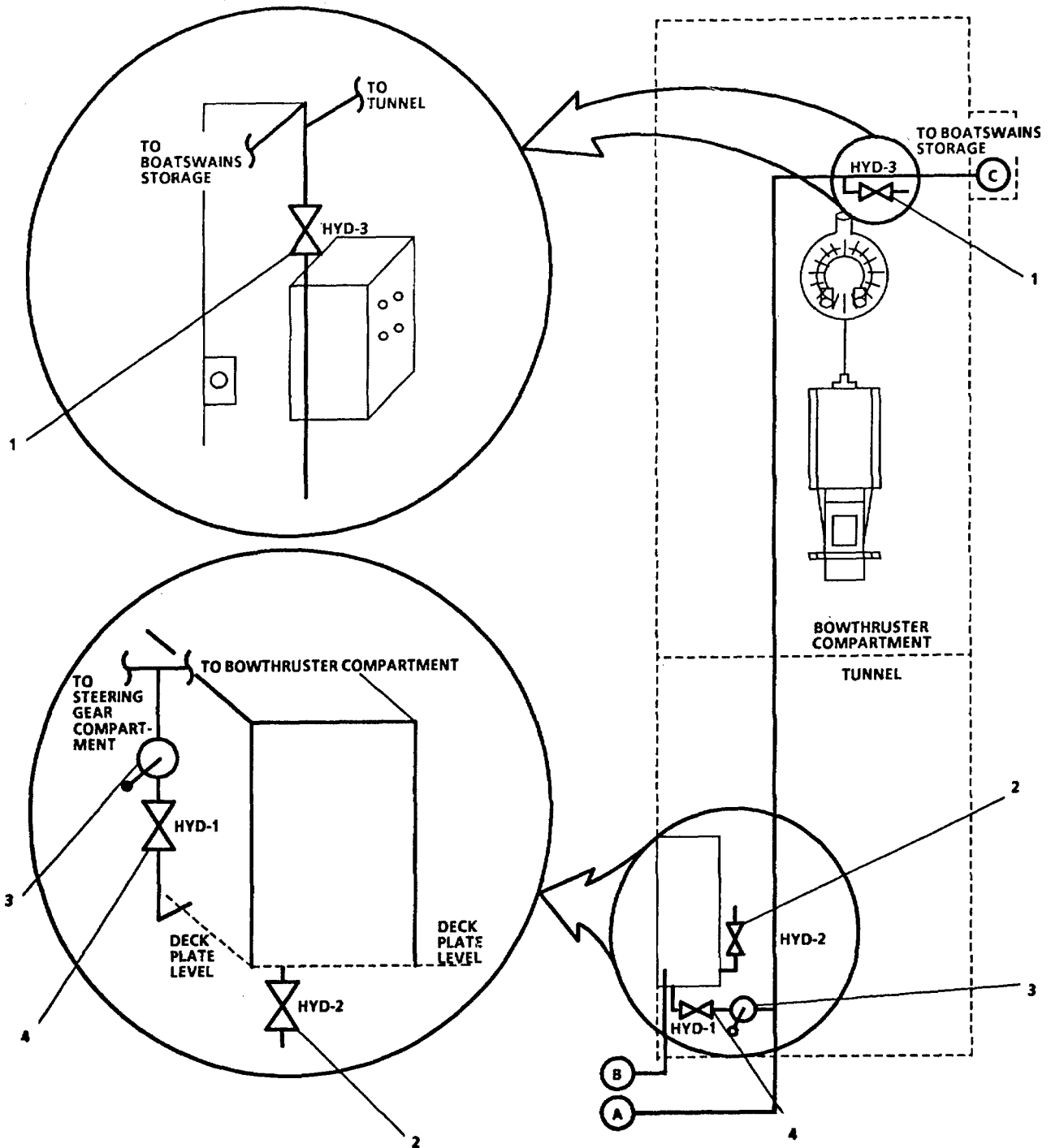

**LEGEND:**

- 1. HYD-3, PWR PACK FILL
- 2. HYD-2, STORAGE TK DRAIN
- 3. HYD OIL HAND PUMP
- 4. HYD-1, HAND PUMP SUCT-STOR TK
- 5. HYD-4, PWR PACK FILL
- 6. HYD-6, PWR PACK FILL
- 7. HYD-5, PWR PACK FILL

FIGURE 2-173. Hydraulic Oil Supply Piping System (Sheet 1 of 3).

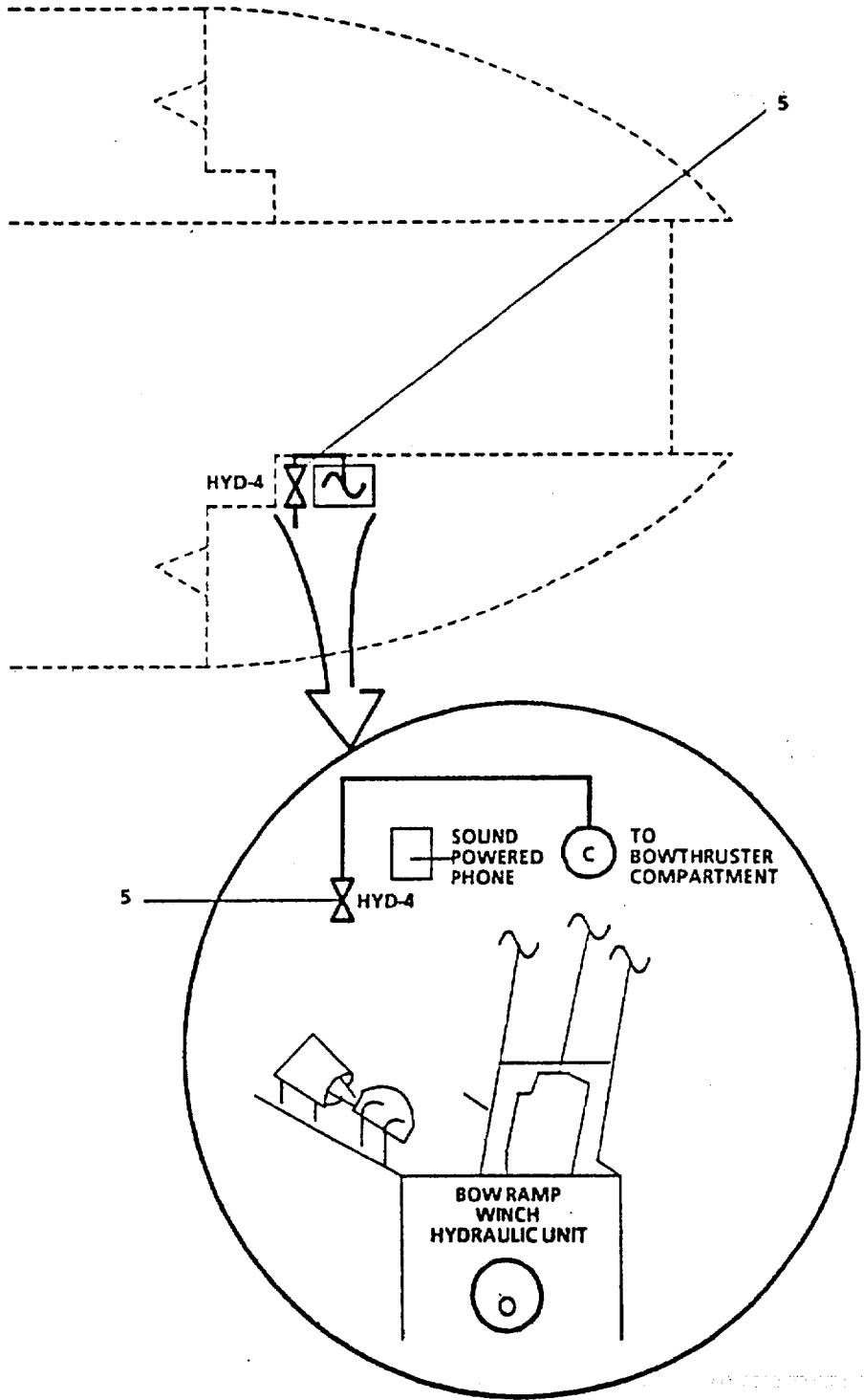
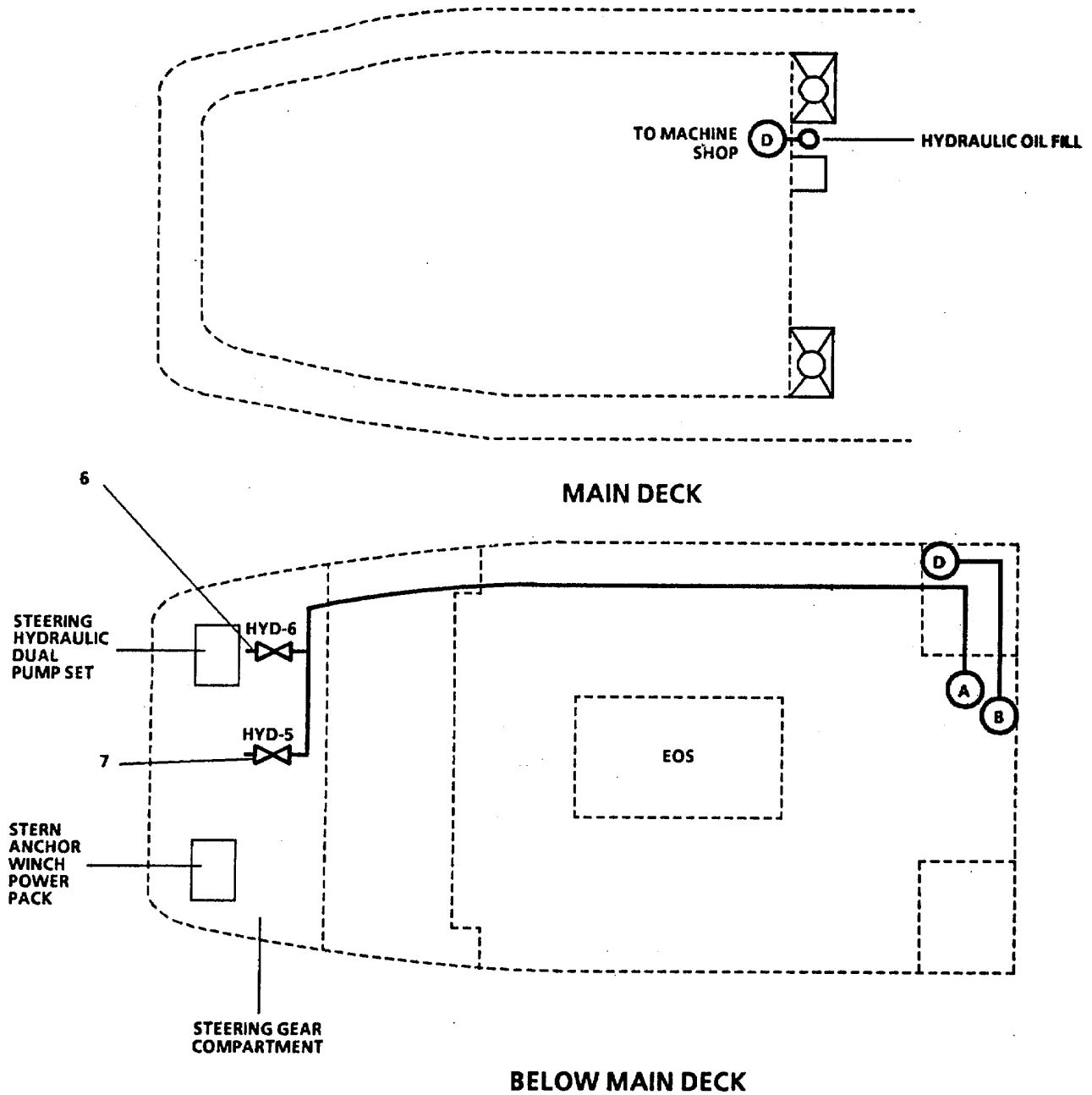

FIGURE 2-173. Hydraulic Oil Supply Piping System (Sheet 3 of 3).



**LEGEND:**

- 6. HYD-6, PWR PACK FILL
- 7. HYD-5, PWR PACK FILL

FIGURE 2-173. Hydraulic Oil Supply Piping System (Sheet 3 of 3).



**CAUTION**

The bow anchor windlass, wildcat, and gypsies are not designed to moor the LCU either on the anchor chain or on the gypsies. The anchor chain should be supported by the chain stoppers. Mooring on the gypsies and lying at anchor on the wildcat will damage or destroy the windlass.

- (1) Startup procedure.
  - (a) On Main Switchboard (FIGURE 2-174) set FWD DECK MCHRY MCC circuit breaker (1) to ON position.
  - (b) At Forward Deck Machinery Motor Control Center (in tunnel) (FIGURE 2-175), set BOW WINDLASS NO 1. circuit breaker (1) and BOW WINDLASS NO. 2 circuit breaker (4) to ON position.

**NOTE**

Ensure that HAND BRAKE WHEEL (2, FIGURE 2-176) is turned clockwise tightly to hold bow anchor in place.

- (c) At Bow Windlass, on Bow Windlass Control Panel (FIGURE 2-177), press START pushbutton (1).
- (d) Check MOTOR RUNNING indicator (2) is lit.
- (2) Lowering anchor by paying out chain.
  - (a) On Bow Anchor Windlass (FIGURE 2-176) engage CLUTCH LEVER (1).

**NOTE**

If clutch does not engage, jog the drive gently by shifting HAUL BACK-PAY OUT switch (4, FIGURE 2-177) to HAUL BACK, then quickly moving it back to neutral. This allows the clutch to engage, taking the strain off chain stopper.

- (b) Lock CLUTCH LEVER (1, FIGURE 2-176) in engaged position.
- (c) Release DEVILS CLAW (5).
- (d) Release CHAIN STOPPER (4)
- (e) Slowly unscrew HAND BRAKE WHEEL (2) counterclockwise to release brake.
- (f) On Bow Anchor Windlass Control Panel (FIGURE 2-177) turn HAUL BACK- PAY OUT switch (4) clockwise to PAY OUT position to pay out anchor chain to the desired length and release switch.
- (g) Turn HAND BRAKE WHEEL (2, FIGURE 2-176) clockwise to set brake.
- (h) Set CHAIN STOPPER (4).
- (i) Engage DEVILS CLAW (5) to anchor chain.

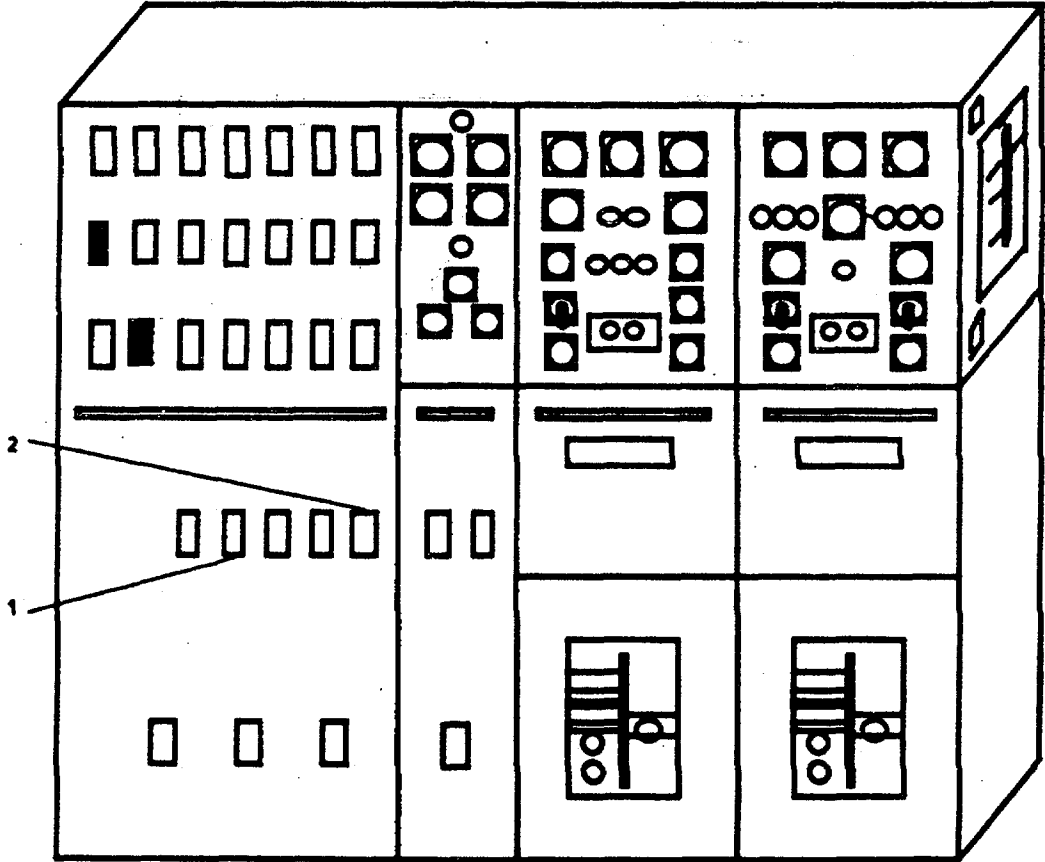

-  **LEGEND**
- 1. FWD DECK MACHINERY MCC CIRCUIT BREAKER
  - 2. BOW RAMP WINCH CIRCUIT BREAKER

FIGURE 2-174. Main Switchboard.

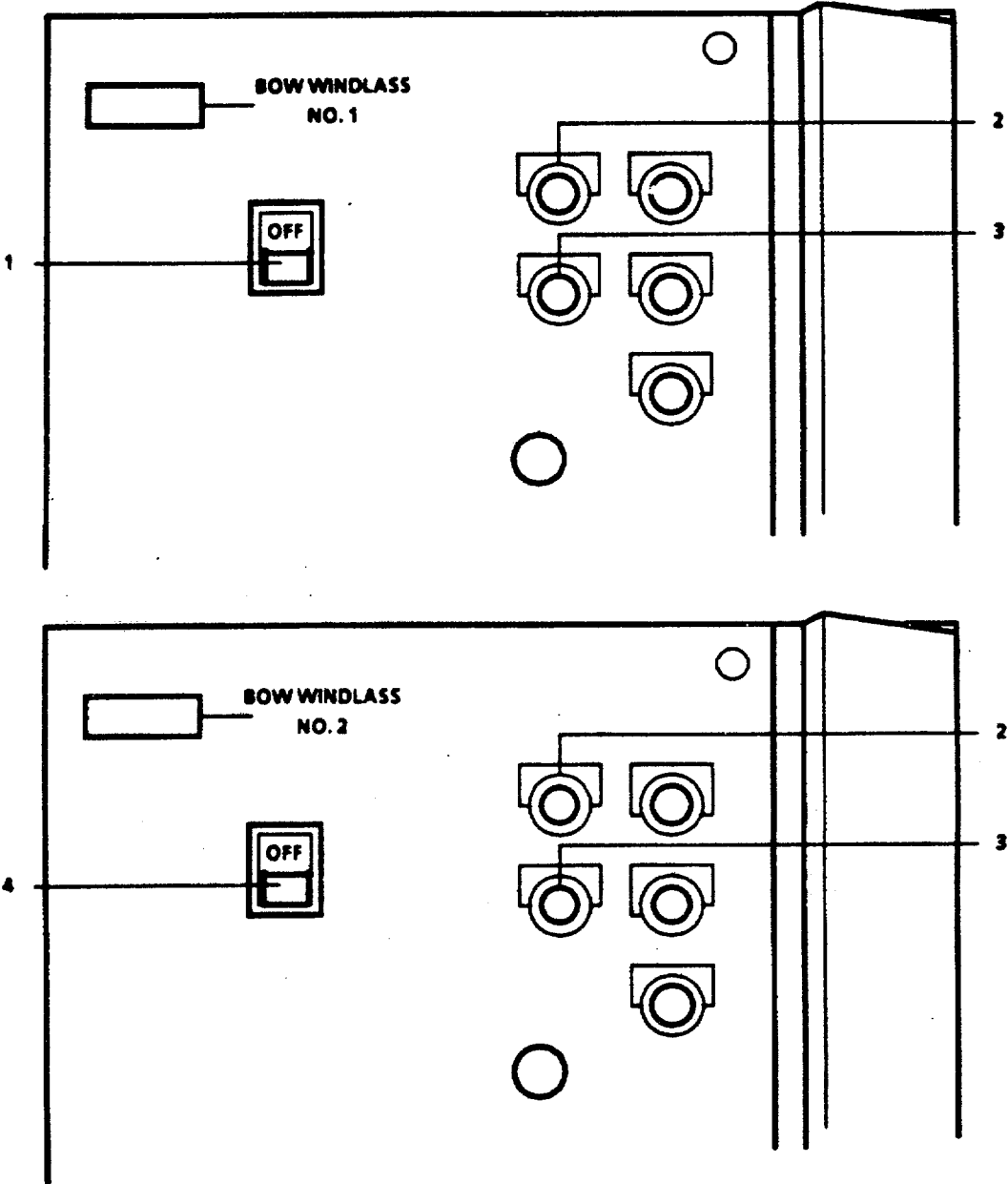

-  **LEGEND**
- 1. CIRCUIT BREAKER
  - 2. START PUSH BUTTON
  - 3. STOP PUSH BUTTON
  - 4. CIRCUIT BREAKER

FIGURE 2-175. Forward Deck Machinery Motor Control Center.



**LEGEND**

- 1. CLUTCH LEVER
- 2. HAND BRAKE WHEEL
- 3. WARPING HEAD

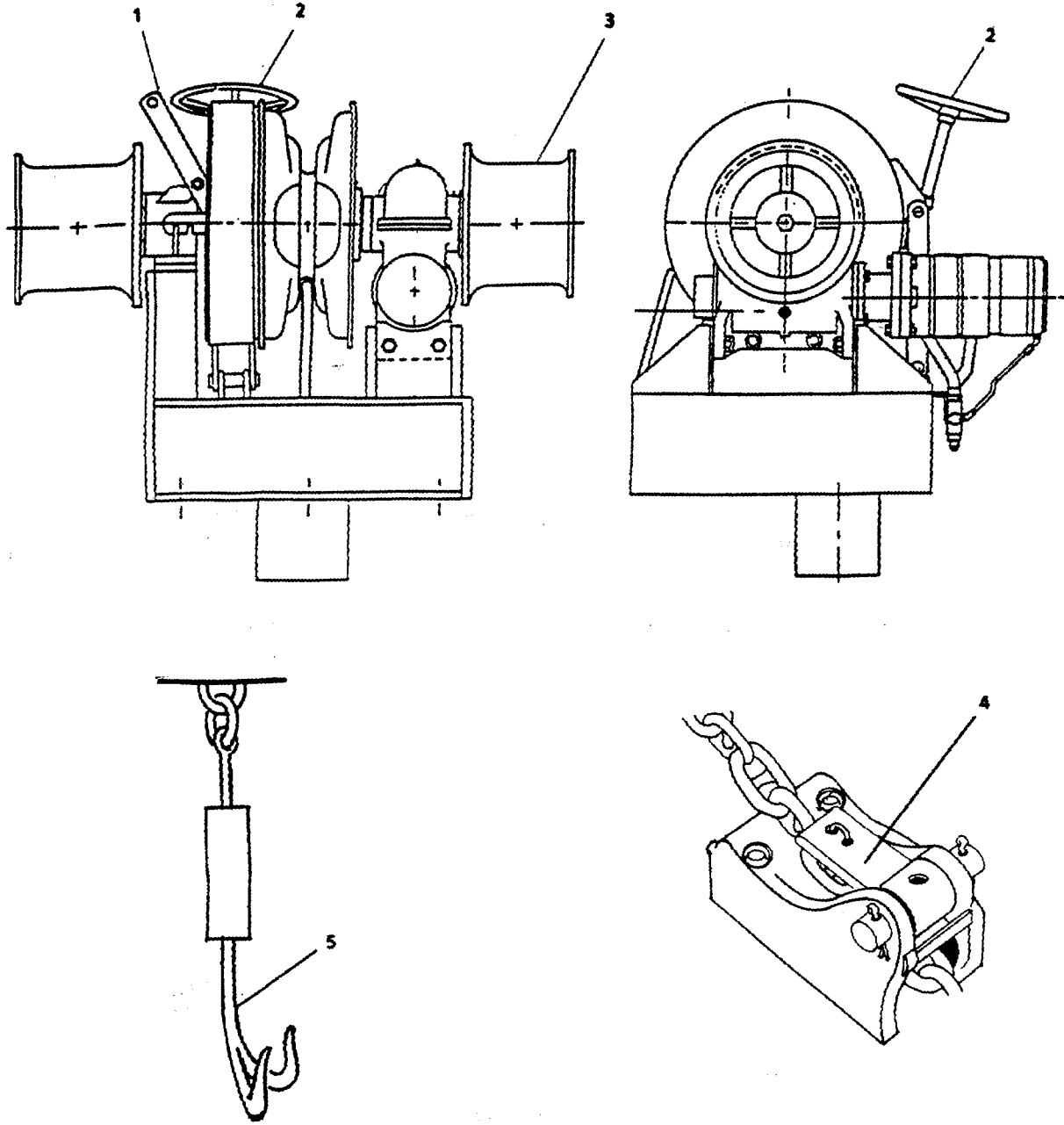
- 4. CHAIN STOPPER
- 5. DEVILS CLAW

FIGURE 2-176. Bow Anchor Windlass.

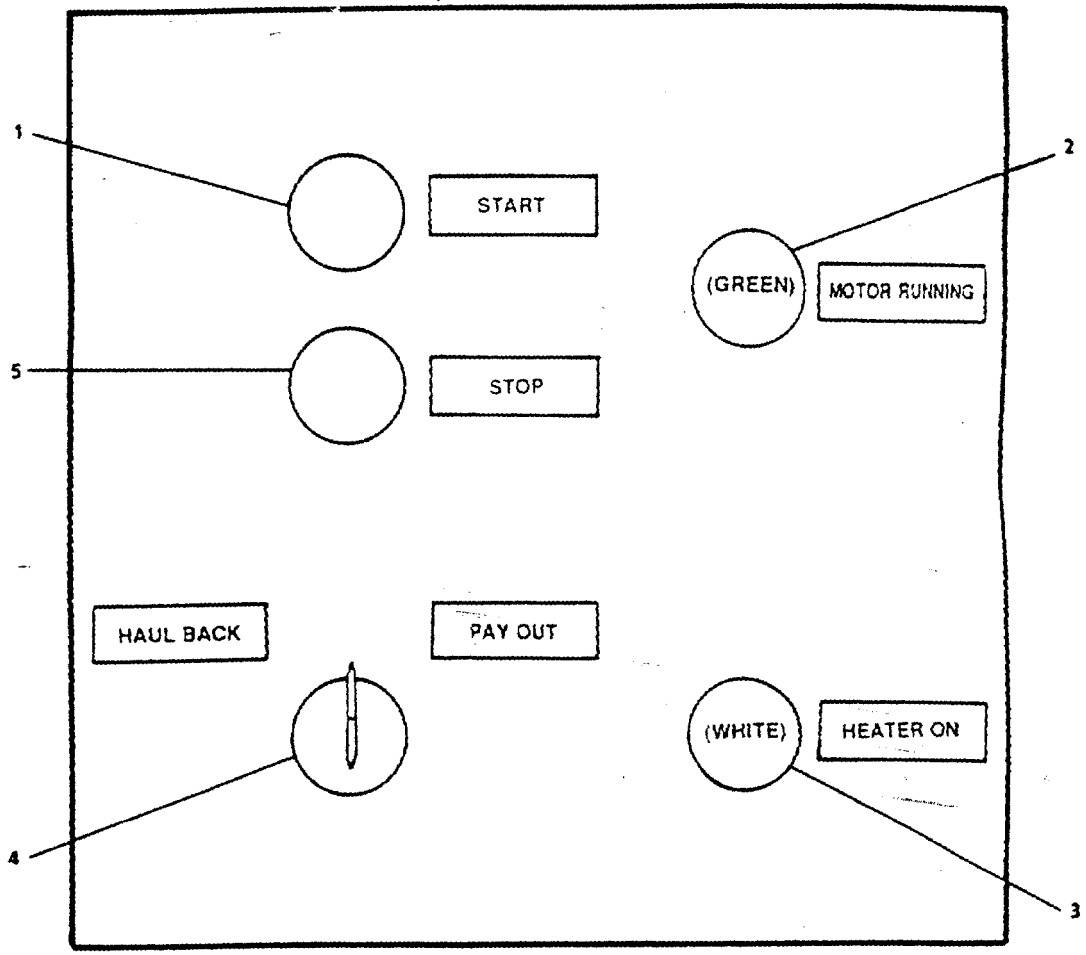

**LEGEND**

- |                  |                      |
|------------------|----------------------|
| 1. START         | 4. HAUL BACK-PAY OUT |
| 2. MOTOR RUNNING | 5. STOP              |
| 3. HEATER ON     |                      |

FIGURE 2-177. Bow Anchor Windlass Control Panel.

**NOTE**

Adjust chain for stopper to fall in place.

- (j) Release CLUTCH LEVER (1).

**NOTE**

If clutch does not release, jog the drive gently by turning HAUL BACK-PAY OUT switch (4, FIGURE 2-177) to PAY OUT, then quickly turning it back to neutral. This allows the clutch to release.

- (3) Lowering anchor by releasing hand brake wheel

**WARNING**

- Before operating windlass, ensure personnel and foreign objects are clear of gypsy, chain, and related components. Moving windlass parts can cause serious personal injury or death.
- High pressure hydraulic systems can cause serious personal injury in the event of equipment failure.
- DO NOT operate hydraulic motor with brake engaged.

**NOTE**

Anchors must be ready for immediate use, such as narrow channels or around docks, anchors can be lowered quickly by simply releasing the hand brake wheel (2, FIGURE 2-176), if windlass is in standby condition.

- (a) Place windlass in standby condition as follows:

- 1 On Bow Anchor Windlass (FIGURE 2-176) set HAND BRAKE WHEEL (2).
- 2 Engage CLUTCH LEVER (1).

**NOTE**

If clutch does not engage, jog the drive gently by turning HAUL BACK-PAY OUT (4, FIGURE 2-177) switch to HAUL BACK, then quickly turning it back to neutral. This allows the clutch to engage, taking the strain off chain stopper.

- 3 Lock CLUTCH LEVER (1, FIGURE 2-176) in engaged position.
  - 4 Release DEVILS CLAW (5).
  - 5 Release CHAIN STOPPER (4).
- (b) Release CLUTCH LEVER (1).

**NOTE**

If clutch does not release, jog the drive gently by turning HAUL BACK-PAY OUT (4, FIGURE 2-177) switch to PAY OUT, then quickly turning it back to neutral. This allows the clutch to release.

**NOTE**

When the bow anchor windlass is in standby condition, the anchor is secured only by the brake and can be released quickly by turning the hand brake wheel (2, FIGURE 2-176) counterclockwise to lower the anchor.

- (c) Turn HAND BRAKE WHEEL (2) counterclockwise slowly to pay out anchor at a ~~slow~~ <sup>slower</sup>. Turn HAND BRAKE WHEEL (2) clockwise to stop anchor descent at desired length.
- (d) Set CHAIN STOPPER (4).
- (4) Hauling in anchor
- (a) Startup procedures.
  - 1 On Main Switchboard (FIGURE 2-174), set FWD DECK MACHRY MCC circuit breaker (1) to ON position.
  - 2 At Forward Deck Machinery Motor Control Center (in tunnel (FIGURE 2-175), set BOW WINDLASS NO. 1. circuit breaker (1) and BOW WINDLASS circuit breaker No 2 circuit breaker (4) to ON position.
  - 3 At Bow Windlass, on Bow Windlass Control Panel (FIGURE 2-177), press START pushbutton (1).
  - 4 Check MOTOR RUNNING indicator (2) is lit.

**WARNING**

- Before operating windlass, ensure personnel and foreign objects are clear of gypsy, chain, and related components. Moving windlass parts can cause serious personal injury or death.
- High pressure hydraulic systems can cause serious personal injury in the event of equipment failure.
- DO NOT operate hydraulic motor with brake engaged.

**CAUTION**

CHAIN STOPPER (4, FIGURE 2-176) should be set during the haul in procedure. As each link in the chain passes, the chain stopper will slip into the next link as the links moves toward the wildcat. This protects the windlass in the event of a hydraulic failure, or the chain jumps the teeth of the wildcat and pays out all the chain with no control.

- (b) Release DEVILS CLAW (5, FIGURE 2-176).
- (c) On Bow Anchor Windlass engage CLUTCH LEVER (1).

**NOTE**

If clutch does not engage, jog the drive gently by turning HAUL BACK-PAY OUT switch (4, FIGURE 2-177) to haul back, and then quickly turning it back to neutral. This allows the clutch to engage, taking the strain off CHAIN STOPPER.

- (d) Lock CLUTCH LEVER (1, FIGURE 2-176) in engaged position.
- (e) Slowly turn HAND BRAKE WHEEL (2) counterclockwise to release brake.
- (f) On Bow Anchor Windlass Control Panel (FIGURE 2-177), turn HAUL BACK-PAY OUT switch (4) counterclockwise to the HAUL BACK position to haul in the anchor chain.
- (g) On Bow Anchor Windlass (FIGURE 2-176) turn HAND BRAKE WHEEL (2) clockwise to engage brake.
- (h) Engage DEVILS CLAW (5).
- (i) Release CLUTCH LEVER (1).

**NOTE**

If clutch does-not release, jog the drive gently by turning HAUL BACK-PAY OUT switch (4, FIGURE 2-177) to PAY OUT, and quickly releasing. Set DEVILS CLAW (5, FIGURE 2-176). This allows the clutch to release.

- (5) Warping Head operation

**WARNING**

- Before operating windlass, be sure personnel and foreign objects are clear of warping head, chain, and related components. Moving windlass parts can cause serious personal injury or death.
- High pressure hydraulic systems can cause serious personal injury in the event of equipment failure.
- DO NOT operate hydraulic motor with brake engaged.

- (a) Startup Procedures.

- 1 On Main Switchboard (FIGURE 2-174), set FWD DECK MCHRY MCC circuit breaker (1) to ON position.
- 2 At Forward Deck Machinery Motor Control Center in Tunnel (FIGURE 2-175), set BOW WINDLASS No. 1 circuit breaker (1) and BOW WINDLASS NO 2 circuit breaker (4) to ON position.



- 3 On Bow Anchor Windlass Control Panel (FIGURE 2-177), press START pushbutton (1).
- 4 Check MOTOR RUNNING indicator (2) is lit.
- (b) On Bow Anchor Windlass (FIGURE 2-176) ensure HAND BRAKE WHEEL (2) is turned fully clockwise; brake is set.
- (c) Ensure CLUTCH LEVER (1) is released and CHAIN STOPPER (4) and DEVILS CLAW (5) is set.
- (d) Slowly unscrew HAND BRAKE WHEEL (2) counterclockwise to release brake.
- (e) On Bow Anchor Windlass Control Panel (FIGURE 2-177), turn HAUL BACK-PAY OUT switch (4) counterclockwise to HAUL BACK position until operation is finished then release HAUL BACK-PAY OUT switch (4).

**NOTE**

Releasing tension on standing end of line will allow gypsy to lose tension on line and cause gypsy to spin inside the wrapped line.

- (f) Turn HAND BRAKE WHEEL (2, FIGURE 2-176) clockwise to set brake.
- (g) On Bow Anchor Windlass Control Panel (FIGURE 2-177), press STOP pushbutton (5) and observe MOTOR RUNNING indicator (2) is not lit.
- (h) At Forward Deck Machinery Control Center (in tunnel) (FIGURE 2-175), set BOW WINDLASS NO. 1 circuit breaker (1) and BOW WINDLASS NO. 2 circuit breakers (4) to OFF position.
- (i) On Main Switchboard (FIGURE 2-174) set FWD DECK MCHRY MCC circuit breaker (1) to OFF position.
- b. Bow Ramp Operation

**WARNING**

- Before operating bow ramp winch, ensure personnel and foreign objects are clear of wire rope drum, wire rope, bow ramp, and related components. Moving winch and ramp parts can cause serious injury or death.
- High pressure hydraulic systems can cause serious personal injury in the event of equipment failure. Shut down hydraulic unit if system pressure exceeds 2,900 psi.

- (1) Startup procedure

**NOTE**

Bow Ramp Operation requires three additional crew members: One crew member on starboard forecastle deck, one crew member on port forecastle deck, and one crew member in Boatswain Storeroom.

- (a) On Main Switchboard (FIGURE 2-174), set BOW RAMP WINCH circuit breaker (2) to ON position.
- (b) In Boatswain Storeroom on Bow Ramp Motor Controller, set circuit breaker to **On** position.
- (c) On Pilothouse Bow Ramp Control Panel (FIGURE 2-178), set POWER OFF-ON switch (1) to ON position.

**NOTE**

Bow Ramp must be operated from position where started.

- (d) Press START pushbutton (5).
  - (e) Check that RUN indicator (6) is lit.
  - (f) Direct crew member in Boatswain Storeroom to read FILTER CONDITION gauge (1, FIGURE 2-179). If needle reads in yellow (change) or red (no filtration) area, press STOP pushbutton (4, FIGURE 2-178), and refer Power Pack to unit maintenance.
- (2) Lower bow ramp

**WARNING**

- Before operating bow ramp winch, ensure personnel and foreign objects are clear of wire rope drum, wire rope, bow ramp, and related components. Moving winch and ramp parts can cause serious injury or death.
- Clear all personnel and equipment from bow ramp and bow ramp path of travel. Moving ramp can cause serious personal injury.

**NOTE**

Ramp can be lowered from either pilothouse starboard forecastle or boatswain storeroom on direction from the pilothouse.

- (a) Direct one crew member to starboard forecastle deck and another crew member to port forecastle deck.
- (b) Set RAISE-LOWER control lever (3, FIGURE 2-178) to RAISE position and hold until rig tightens and load is off locking assembly.
- (c) Direct crew members on forecastle decks to turn RATCHET HANDLE (3, FIGURE 2-180) of locking assembly to release LOCKING CLAMP (2).
- (d) Direct crew members on forecastle decks to remove LOCKOUT PIN (5) and pull CHAIN STOPPER HANDLE (4) aft to release port and starboard CHAIN STOPPER (1). Reinstall LOCKOUT PIN (5) to prevent CHAIN STOPPER (1) from engaging chain during operation.

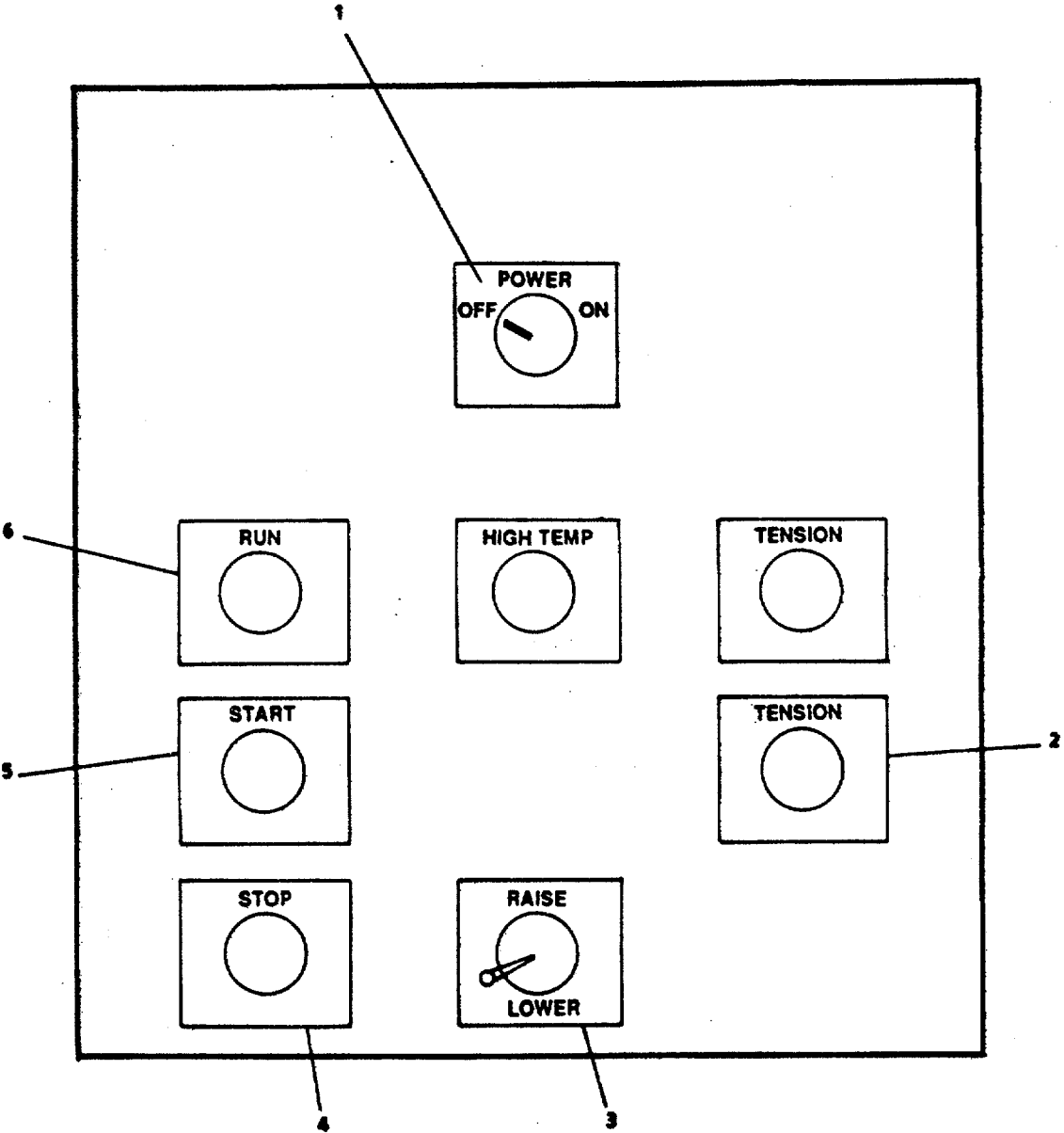

**LEGEND**

- |                              |                        |
|------------------------------|------------------------|
| 1. POWER OFF/ON SWITCH       | 4. STOP PUSH BUTTON    |
| 2. TENSION PUSH BUTTON       | 5. START PUSH BUTTON   |
| 3. RAISE/LOWER CONTROL LEVER | 6. RUN INDICATOR LIGHT |



FIGURE 2-178. Pilothouse Bow Ramp Control Panel.

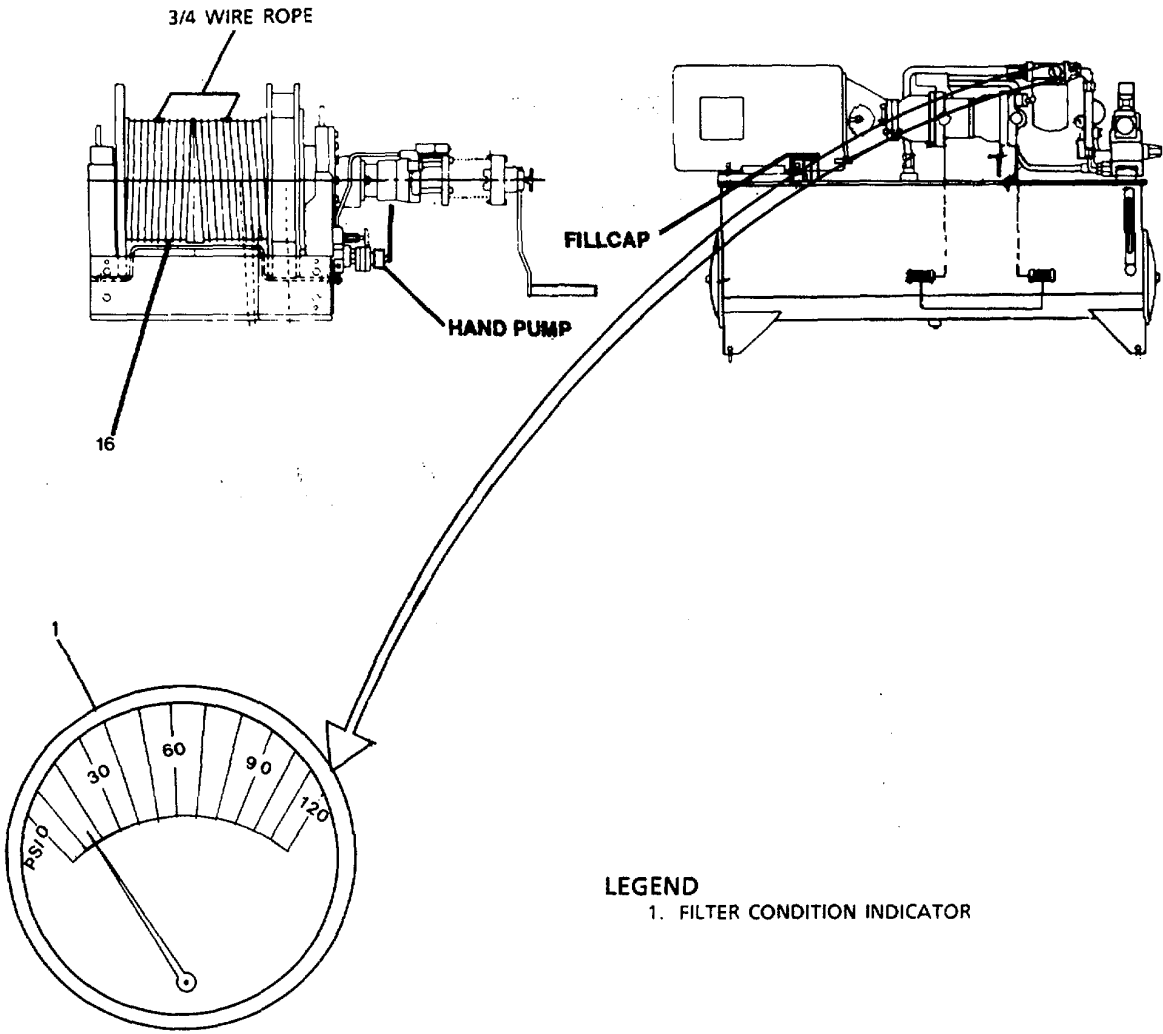
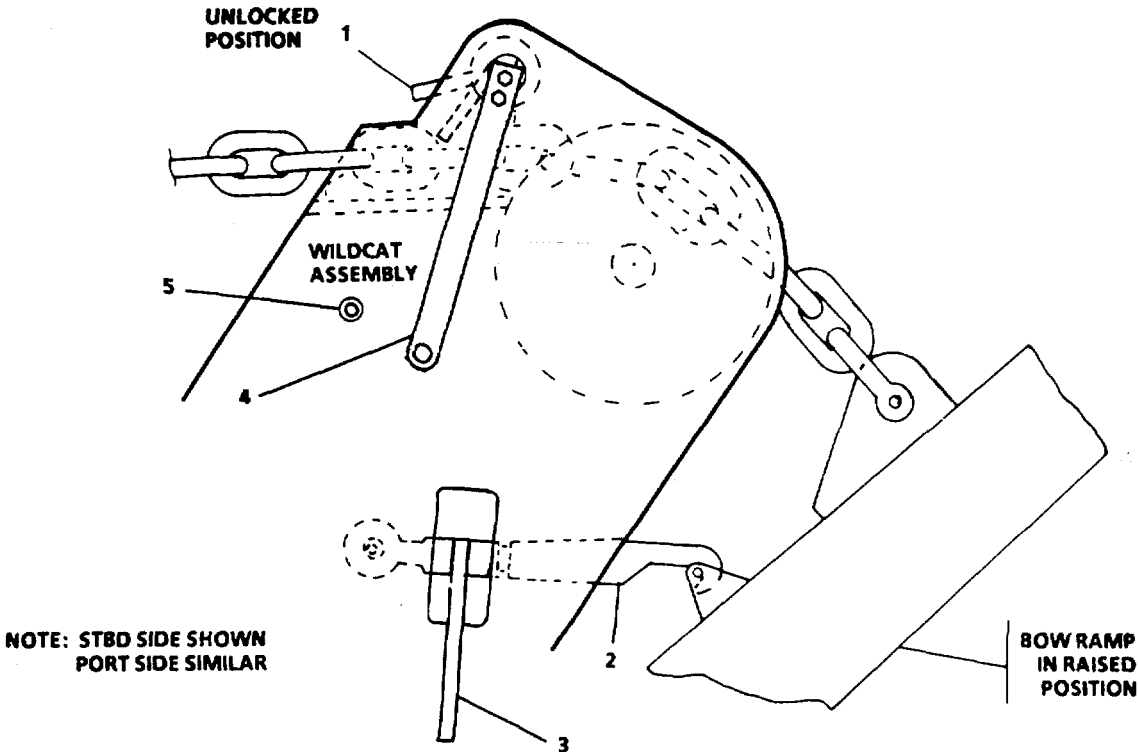

FIGURE 2-179. Bow Ramp Winch Gauge(s).



**LEGEND**

- 1. CHAIN STOPPER
- 2. LOCKING CLAMP
- 3. RATCHET HANDLE
- 4. CHAIN STOPPER HANDLE
- 5. LOCKOUT PIN

FIGURE 2-180. Bow Ramp Locking Assembly.

- (e) Set RAISE-LOWER control lever (3, FIGURE 2-178) to LOWER position and hold till ramp is deployed.

**CAUTION**

When operating in constant tension mode, the chain stoppers must be disengaged.

- (f) Press TENSION pushbutton (2, FIGURE 2-178) to maintain tension in rigging.
- (3) Raise bow ramp.

**WARNING**

- Before operating bow ramp winch, ensure personnel and foreign objects are clear of wire rope drum, wire rope, bow ramp, and related components. Moving winch and ramp parts can cause serious injury or death.
- Clear all personnel and equipment from bow ramp and bow ramp path of travel. Moving ramp can cause serious personal injury.

**NOTE**

Ramp can be raised from either the pilothouse or the boatswain storeroom on direction from the pilothouse.

- (a) Direct one crew member to starboard forecastle deck and another crew member to port forecastle deck.
- (b) Direct crew members on forecastle decks to remove LOCKOUT PIN (5, FIGURE 2-180) and leave PIN out, pull CHAIN STOPPER HANDLE (4) forward to set port and starboard CHAIN STOPPER (1).

**CAUTION**

CHAIN STOPPER (1) should be set during haul in procedure. As each link in chain passes, chain stopper will slip into next link as links move toward winch. This protects windlass in event of hydraulic failure. LOCKOUT PIN (5) must be left out to prevent damage to handle.

- (c) On Pilothouse Bow Ramp Control Panel (FIGURE 2-178), set RAISE/LOWER CONTROL LEVER (3) to RAISE position and hold until ramp is in up position and rig tightens, release RAISE-LOWER CONTROL LEVER (3).

**NOTE**

- Constant tension will automatically be cancelled.
- Ratchet handle has reversible yoke which must be properly positioned down to tighten.

- (d) Direct crew members on forecastle decks to turn RATCHET HANDLE (3, FIGURE 2-180) and secure LOCKING CLAMP (2) on the ramp stud. Install LOCKOUT PINS (5).
- (e) On Pilothouse Bow Ramp Control Panel (FIGURE 2-178), press STOP pushbutton (4).
- (f) On Pilothouse Bow Ramp Control Panel (FIGURE 2-178), set POWER ON-OFF switch (1) to OFF position.
- (g) In Boatswain Storeroom on Bow Ramp Motor Controller, press STOP pushbutton and observe MOTOR STOP indicator out.
- (h) On Main Switchboard (FIGURE 2-174), set BOW RAMP WINCH circuit breaker (2) to OFF position.

**2-22. Stern Anchor Winch Operation.**

**WARNING**

- Before operating stern anchor winch, ensure personnel and foreign objects are clear of wire rope drum, wire rope, and related components. Moving winch, wire rope and gypsies can cause serious injury or death.
- Keep all personnel clear of winch and wire rope while in operation.
- Keep all personnel clear of moving and rotating parts of winch.
- Do not attempt to perform any maintenance or repairs while winch is running
- Do not operate this winch with guards removed.
- Do not operate hydraulic motor with brake engaged.

a. Startup Procedure.

- (1) On Main Switchboard (FIGURE 2-181), set STERN ANCHOR WINCH circuit breaker (1) to ON position.
- (2) On STERN ANCHOR WINCH MOTOR CONTROLLER (FIGURE 2-182) (located in passageway) set ON-OFF switch (1) to ON position.
- (3) On STERN CONTROL BOX (FIGURE 2-183), press START pushbutton (1).
- (4) Check MOTOR RUNNING indicator light (2) is lit.

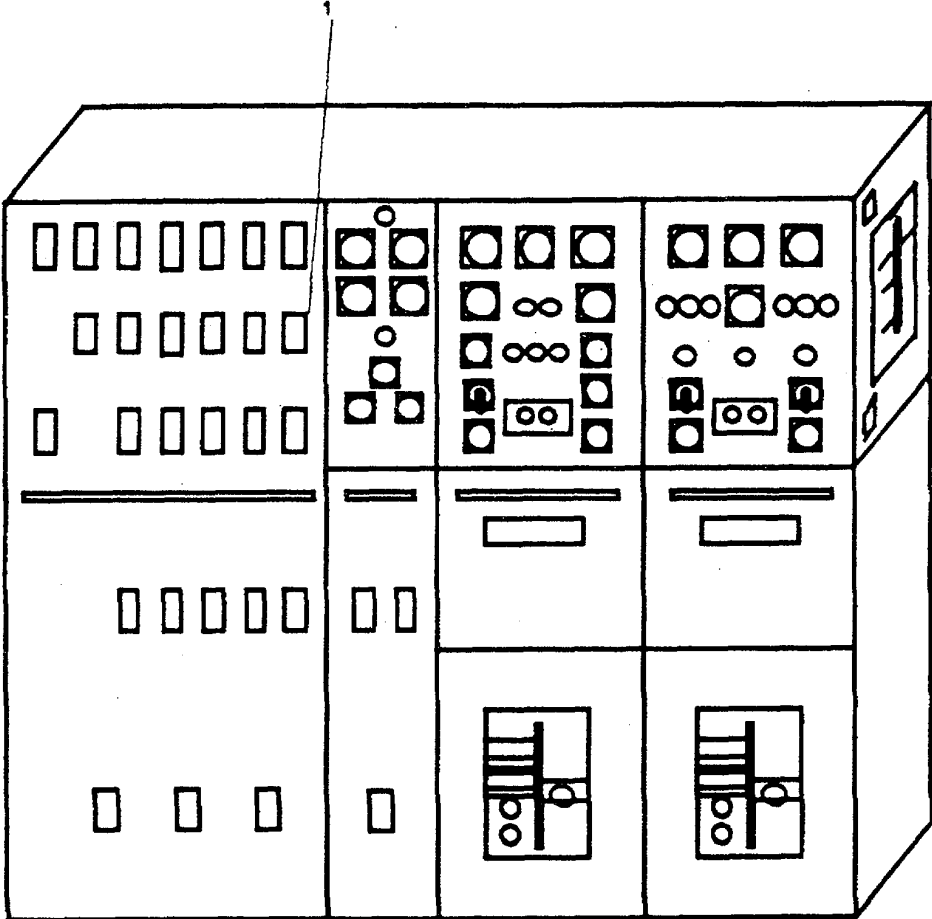

**LEGEND**

- 1. STERN ANCHOR WINCH CIRCUIT BREAKER



FIGURE 2-181. Main Switchboard.



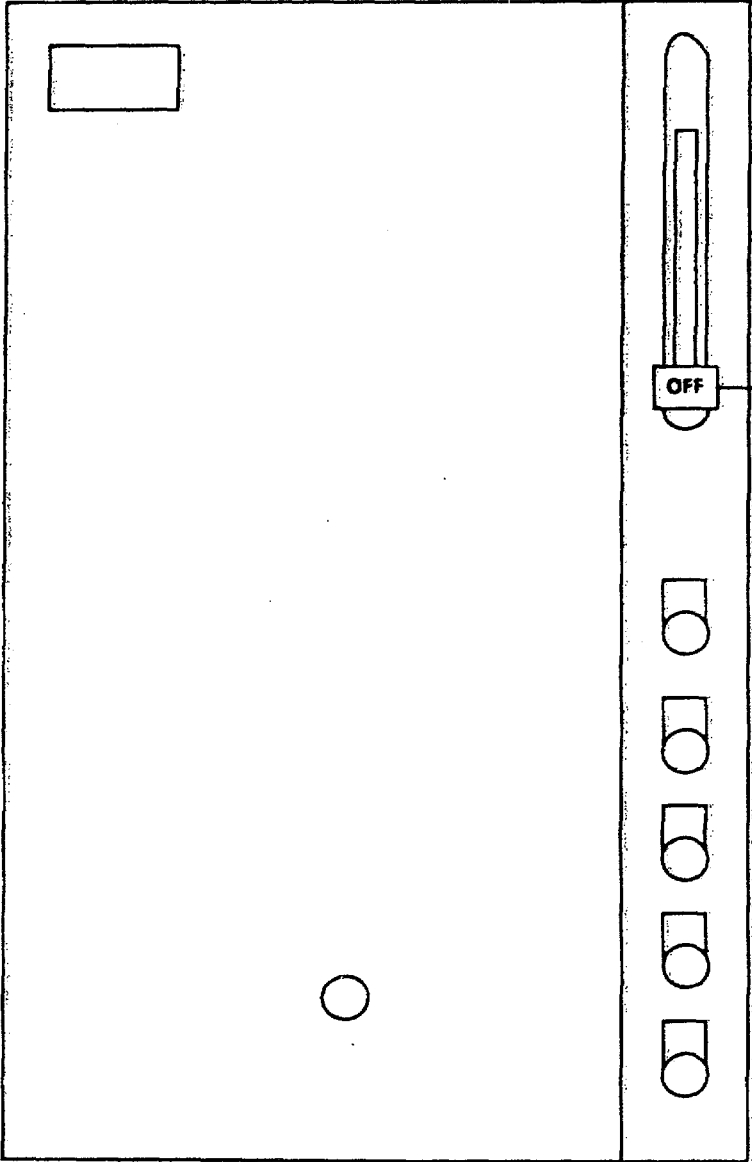

**LEGEND**  
1. CIRCUIT BREAKER HANDLE

FIGURE 2-182. Stern Anchor Winch Motor Controller.

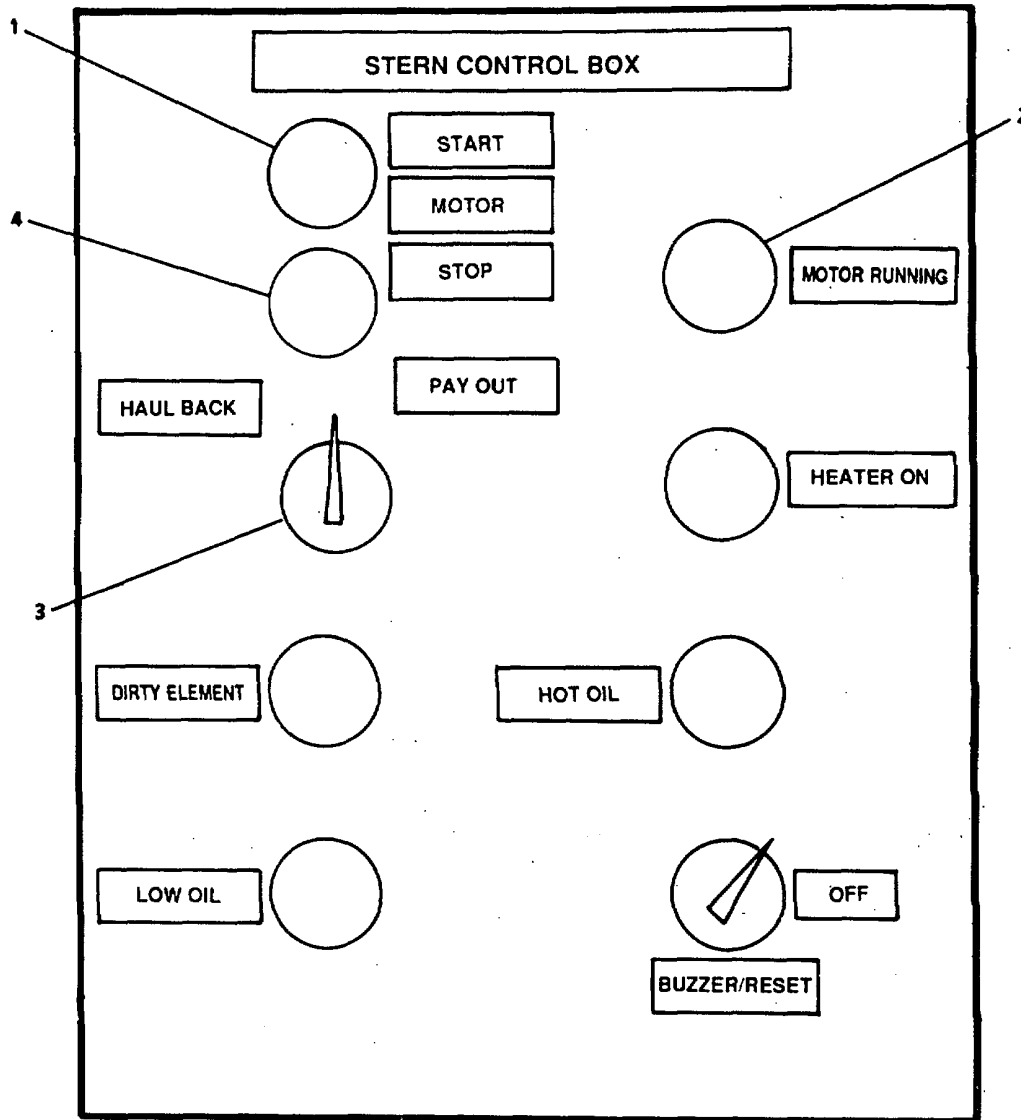

**LEGEND**

- |                            |                      |
|----------------------------|----------------------|
| 1. START                   | 3. HAUL BACK-PAY OUT |
| 2. MOTOR RUNNING INDICATOR | 4. STOP              |

FIGURE 2-183. Stern Control Box.

**WARNING**

- Before operating stern anchor winch, ensure personnel and foreign objects are clear of wire rope drum, wire rope, and related components. Moving winch, wire rope and gypsies can cause serious injury or death.
- Keep all personnel clear of winch and wire rope while in operation.
- Keep all personnel clear of moving and rotating parts of winch.
- Do not attempt to perform any maintenance or repairs while winch is running
- Do not operate this winch with guards removed.
- Do not operate hydraulic motor with brake engaged.

**NOTE**

On first wrap down (fast) speed is 35 FPM (feet per minute) and up (slow) speed is 17 FPM.

b. Lowering Anchor by Paying Out Wire Rope

- (1) On Stern Anchor Winch (FIGURE 2-184) engage CLUTCH LEVER (4).

**NOTE**

If clutch does not engage, jog drive gently by turning HAUL BACK-PAY OUT switch to haul back, and then quickly release it. This allows clutch to engage, taking strain off anchor hold back wire rope.

- (2) Lock CLUTCH LEVER (4).
- (3) Disconnect ANCHOR HOLDBACK turnbuckle (1, FIGURE 2-185) from anchor.
- (4) Disengage dog lever as follows:
  - (a) Slowly turn BRAKE HANDWHEEL (2, FIGURE 2-184) counterclockwise to release brake.
  - (b) Slowly turn HAUL BACK-PAY OUT switch (3, FIGURE 2-183) to HAUL BACK position until dog lug is free from MAIN SPOOL (1, FIGURE 2-184).
  - (c) Push DOG LEVER (3), aft until dog is away from MAIN SPOOL (1).
- (5) On Stern Control Box (FIGURE 2-183), turn HAUL BACK-PAY OUT switch (3) clockwise to PAY OUT position to pay out anchor wire rope to the desired length. Release HAUL BACK-PAY OUT switch (3).

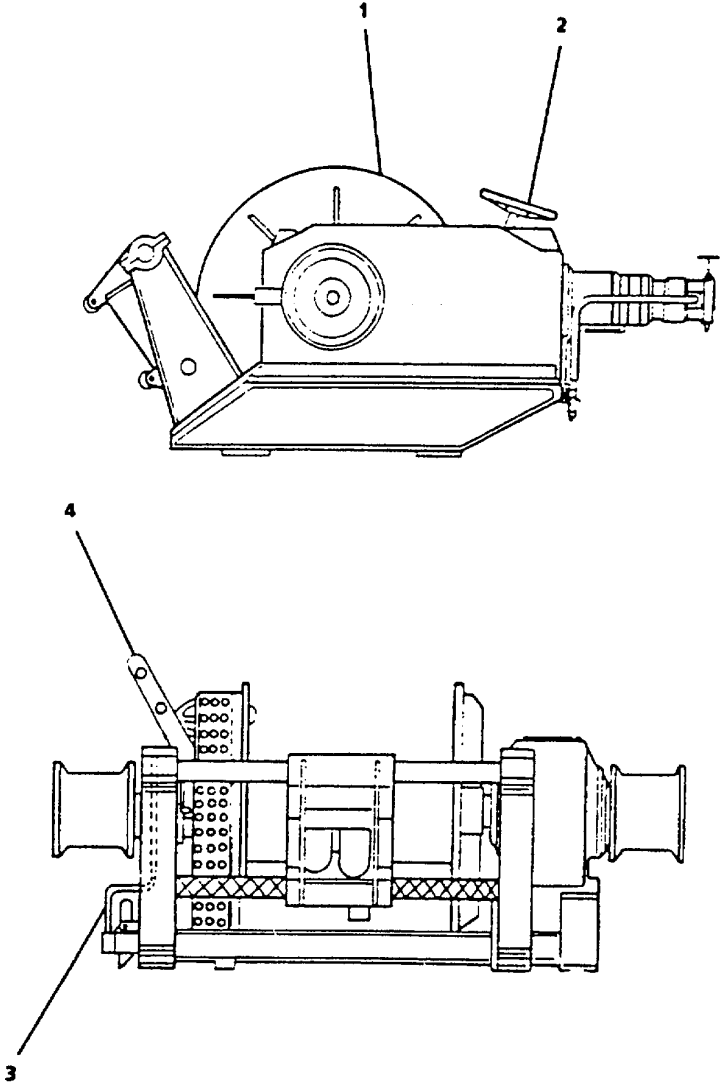

- LEGEND**
- |                    |                 |
|--------------------|-----------------|
| 1. MAIN SPOOL      | 3. DOG LEVER    |
| 2. BRAKE HANDWHEEL | 4. CLUTCH LEVER |

FIGURE 2-184. Stern Anchor Winch.

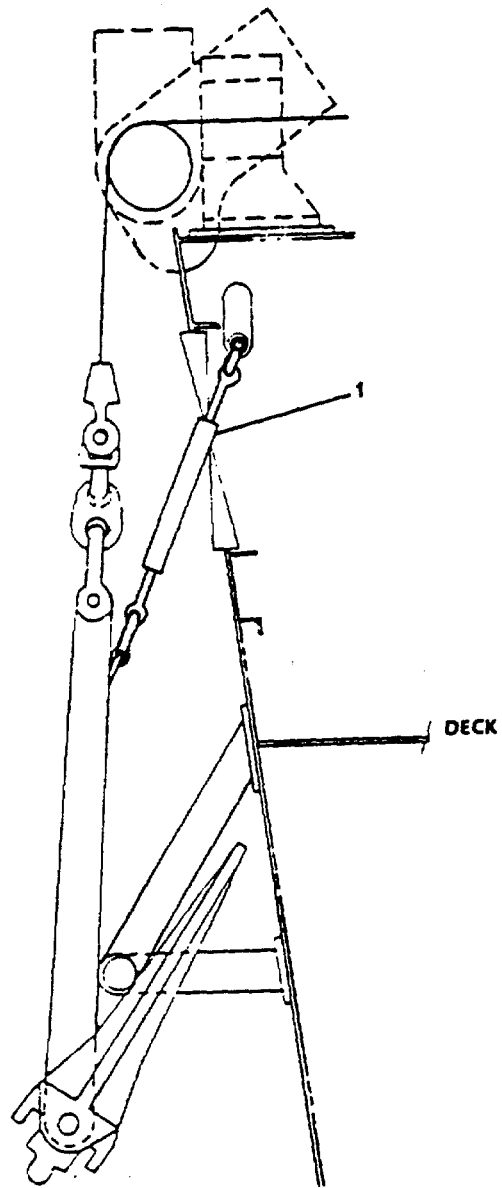

**LEGEND**  
1. ANCHOR HOLDBACK TURNBUCKLE

FIGURE 2-185. Turnbuckle.

- (6) Engage dog lug on MAIN SPOOL (1, FIGURE 2-184) as follows:
  - (a) Turn HAUL BACK-PAY OUT switch (3, FIGURE 2-183) to allow MAIN SPOOL (1, FIGURE 2-184) to creep until dog lug will enter the spool flange.
  - (b) Pull DOG LEVER (3) forward, setting dog.
- (7) On Stern Anchor Winch (FIGURE 2-184) turn BRAKE HANDWHEEL (2) clockwise to set brake.
- (8) Release CLUTCH LEVER (4).

**NOTE**

If clutch does not release, jog drive gently by moving HAUL BACK-PAY OUT switch (3, FIGURE 2-183) to pay out, and quickly release it. This allows the clutch to release.

- c. Lowering Anchor by Releasing Brake Handwheel

**WARNING**

- Before operating stern anchor winch, ensure personnel and foreign objects are clear of wire rope drum, wire rope, and related components. Moving winch, wire rope and gypsies can cause serious injury or death.
  - Keep all personnel clear of winch and wire rope while in operation.
  - Keep all personnel clear of moving and rotating parts of winch.
  - Do not attempt to perform any maintenance or repairs while winch is running
  - Do not operate this winch with guards removed.
  - Do not operate hydraulic motor with brake engaged.
  - Wear life jacket and use safety line when removing turnbuckle from anchor to prevent injury from propellers in the event of falling overboard.
- (1) Place winch in standby condition as follows:
    - (a) On Stern Anchor Winch (FIGURE 2-184) ensure BRAKE HANDWHEEL (2) is set.
    - (b) Engage DOG LEVER (3).
    - (c) Engage CLUTCH LEVER (4).

**NOTE**

If clutch does not engage, jog drive gently by shifting HAUL BACK-PAY OUT switch (3, FIGURE 2-183) to haul back, and then quickly release it. This allows the clutch to engage, taking strain off anchor holdback wire rope.

- (d) Lock CLUTCH LEVER (4, FIGURE 2-184).
- (e) Disconnect ANCHOR HOLDBACK TURNBUCKLE (1, FIGURE 2-185).
- (f) Slowly turn BRAKE HANDWHEEL (2, FIGURE 2-184) counterclockwise to release brake.
- (g) Slowly turn HAUL BACK-PAY OUT SWITCH (3, FIGURE 2-183) to HAUL BACK position until dog lug is free in MAIN SPOOL (1, FIGURE 2-184).
- (h) Push DOG LEVER (3) aft until dog is away from MAIN SPOOL (1).
- (i) Turn BRAKE HANDWHEEL (2) clockwise, to tighten brake.
- (2) Release CLUTCH LEVER (4).

**NOTE**

- If clutch does not release, jog drive gently by shifting HAUL BACK- PAY OUT switch to PAY OUT, and quickly releasing it. This allows the clutch to release.
- With stern anchor winch in standby condition, anchor is secured only by brake and can be quickly released by turning brake handwheel counterclockwise to lower the anchor.

**CAUTION**

Do not pay out the last row of the cable on the drum. Loss of anchor or improper rewinding of cable may occur. The operator may paint the last row of the cable left on the drum, 'yellow' for a quick reminder during operation.

- (3) Turn BRAKE HANDWHEEL (2) counterclockwise slowly to pay out anchor at a slow speed. Turn BRAKE HANDWHEEL (2) clockwise to stop anchor descent at desired length.
- (4) Engage dog lug on MAIN SPOOL (1) as follows:
  - (a) Engage CLUTCH LEVER (4).
  - (b) Turn HAUL BACK-PAY OUT switch (3, FIGURE 2-183) to allow MAIN SPOOL (1, FIGURE 2-184) to creep until dog lug will enter the spool flange.
  - (c) Pull DOG LEVER (3) forward, setting dog.

d. Hauling In Anchor.**WARNING**

- Before operating stern anchor winch, ensure personnel and foreign objects are clear of wire rope drum, wire rope, and related components. Moving winch, wire rope and gypsies can cause serious injury or death.
- Keep all personnel clear of winch and wire rope while in operation.
- Keep all personnel clear of moving and rotating parts of winch.
- Do not attempt to perform any maintenance or repairs while winch is running
- Do not operate this winch with guards removed.
- Do not operate hydraulic motor with brake engaged.

(1) On Stern Anchor Winch (FIGURE 2-184) engage CLUTCH LEVER (4).

**NOTE**

If clutch does not engage, jog drive gently by turning HAUL BACK-PAY OUT switch to HAUL BACK, and then quickly release it. This allows the clutch to engage.

- (2) Lock CLUTCH LEVER (4) in engaged position.
- (3) Disengage DOG LEVER (3) as follows:
  - (a) Slowly turn BRAKE HANDWHEEL (2) counterclockwise to release brake.
  - (b) Slowly move HAUL BACK-PAY OUT switch (3, FIGURE 2-183) to HAUL BACK position until dog lug is free in MAIN SPOOL (1, FIGURE 2-184).
  - (c) Push DOG LEVER (3) aft until dog is-away from MAIN SPOOL (1).
- (4) On Stern Control Box (FIGURE 2-183), turn HAUL BACK-PAY OUT switch (3) counterclockwise to HAUL BACK position and haul in anchor.
- (5) Release HAUL BACK-PAY OUT switch (3).
- (6) Engage dog lug on MAIN SPOOL (1, FIGURE 2-184) as follows:
  - (a) Turn HAUL BACK-PAY OUT switch (3, FIGURE 2-183) to allow MAIN SPOOL (1, FIGURE 2-184) to creep until dog lug will enter the spool flange.
  - (b) Pull DOG LEVER (3) forward to set DOG. Ensure DOG can not be removed from main spool without aid of the HAUL BACK - PAYOUT switch. Pull DOG LEVER (3) forward, setting dog.
- (7) Turn BRAKE HANDWHEEL (2) clockwise to set brake.
- (8) Attach ANCHOR HOLDBACK turnbuckle (1, FIGURE 2-185).



- (9) Release CLUTCH LEVER (4, FIGURE 2-184).

**NOTE**

If clutch does not release, jog drive gently by shifting HAUL BACK-PAY OUT switch to pay out, and quickly release it. This allows the clutch to release.

- e. Warping Head Operation.

**WARNING**

- Before operating stern anchor winch, ensure personnel and foreign objects are clear of wire rope drum, wire rope, and related components. Moving winch, wire rope and warping heads can cause serious injury or death.
  - Keep all personnel clear of winch and wire rope while in operation.
  - Keep all personnel clear of moving and rotating parts of winch.
  - Do not attempt to perform any maintenance or repairs while winch is running.
  - Do not operate this winch with guards removed.
  - Do not operate hydraulic motor with brake engaged.
- (1) On Stern Anchor Winch (FIGURE 2-184) ensure BRAKE HANDWHEEL (2) is fully clockwise, brake is set. Ensure CLUTCH LEVER (4) is released, and dog is engaged.
- (2) On Stern Control Box (FIGURE 2-183), turn HAUL BACK-PAY OUT switch (3) counterclockwise to haul back position.

**NOTE**

Releasing tension on standing end of line will allow warping head to lose tension on line and allow warping head to spin inside the wrapped line.

- (3) Release HAUL BACK-PAY OUT switch (3, FIGURE 2-183), stopping the warping head pull on the line.

- f. Shutdown.

- (1) On Stern Control Box (FIGURE 2-183) press STOP pushbutton (4).
- (2) On Stern Anchor Winch Motor Controller (FIGURE 2-182) (located in passageway) set ON-OFF switch (1) to OFF position.
- (3) On Main Switchboard (FIGURE 2-181), set STERN ANCHOR WINCH circuit breaker (1) to OFF position.

**2-23. Engine Order Telegraph (EOT).** The Engine Order Telegraph is used when Pilothouse is not in control of main propulsion system. Orders are issued by Pilothouse to Engine Room Operating Station to change engine speed or direction (forward or reverse). The following procedures will be used at Pilothouse Console (PHC) and the Engine Room Operating Station Console (ERC).

a. Pilothouse Console (PHC).

- (1) On 24V Distribution Panel, set ENGINE ORDER TELEGRAPH switch (1, FIGURE 2-186) to ON position. This panel is located in the communications area.
- (2) On the Pilothouse Console EOT Panel (FIGURE 2-187) select the direction and speed desired. Example: port slow speed ahead, press port SLOW AHEAD pushbutton indicator (1).

**NOTE**

Alarm will sound at PHC and SLOW AHEAD pushbutton indicator will light.

- (3) The Pilothouse will know the order is acknowledged when the alarm stops. The port SLOW AHEAD pushbutton indicator (1) will remain on.

b. Engine Room Operating Station (EOS).

- (1) In the Engine Room Operating Station an alarm will sound; port SLOW AHEAD pushbutton indicator (1) will flash.
- (2) Press port SLOW AHEAD pushbutton indicator (1) to acknowledge order has been received. The alarm will stop, and pushbutton indicator will remain on.

**NOTE**

- Wrong direction indicator will flash until the throttle is placed in the proper direction.
- All order pushbutton indicators on EOT operate in the same manner.

c. Transferring Control Air to Bridge.

- (1) At Pilothouse Console, push BRIDGE CONTROL pushbutton indicators (2 and 3, FIGURE 2-187) at the same time.
- (2) After EOS acknowledges pull up CONTROL AIR STA TRANSFER VALVE (3, FIGURE 2-188).
- (3) THROTTLE AIR PRESSURE gauge (2) needle indicates air pressure at Pilothouse Console.

d. Ordering Engines to Be Secured

- (1) Press FINISHED WITH ENGINES (4, FIGURE 2-187); EOS will acknowledge.

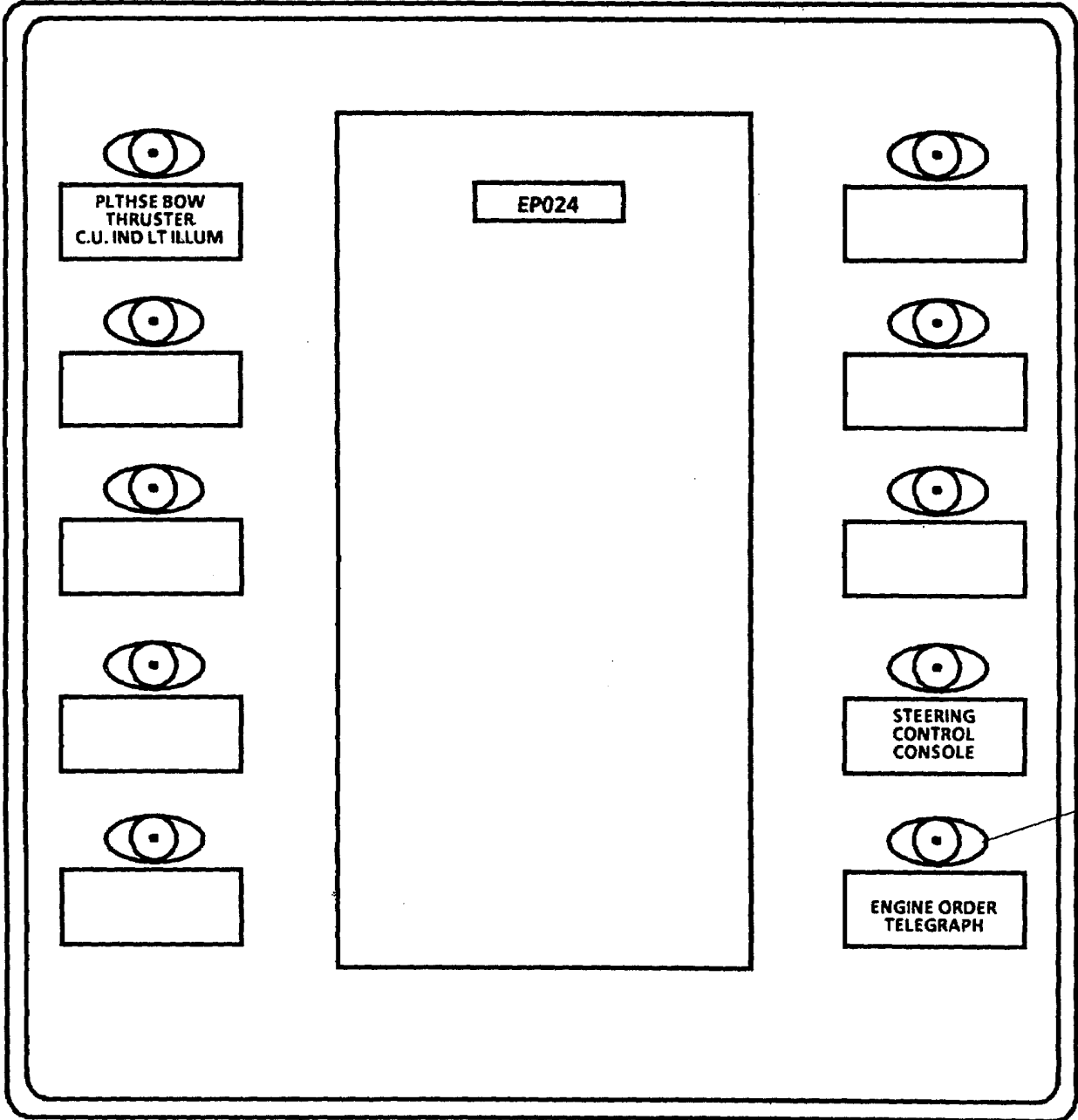
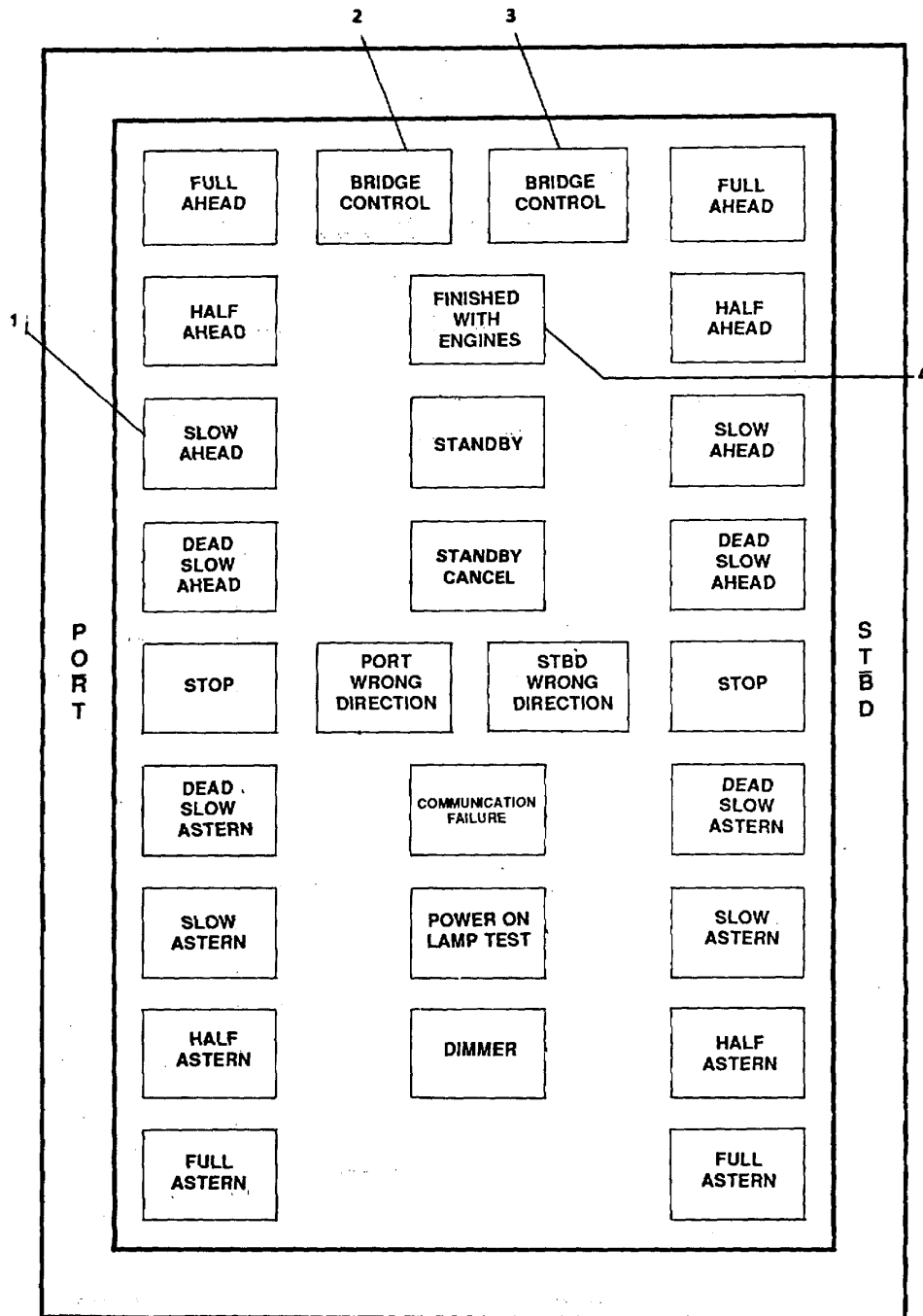

FIGURE 2-186. 24V Distribution Panel.



**LEGEND**

- 1. PORT ENGINE SLOW AHEAD
- 2. BRIDGE CONTROL
- 3. BRIDGE CONTROL
- 4. FINISHED WITH ENGINES

FIGURE 2-187. EOT Panel.

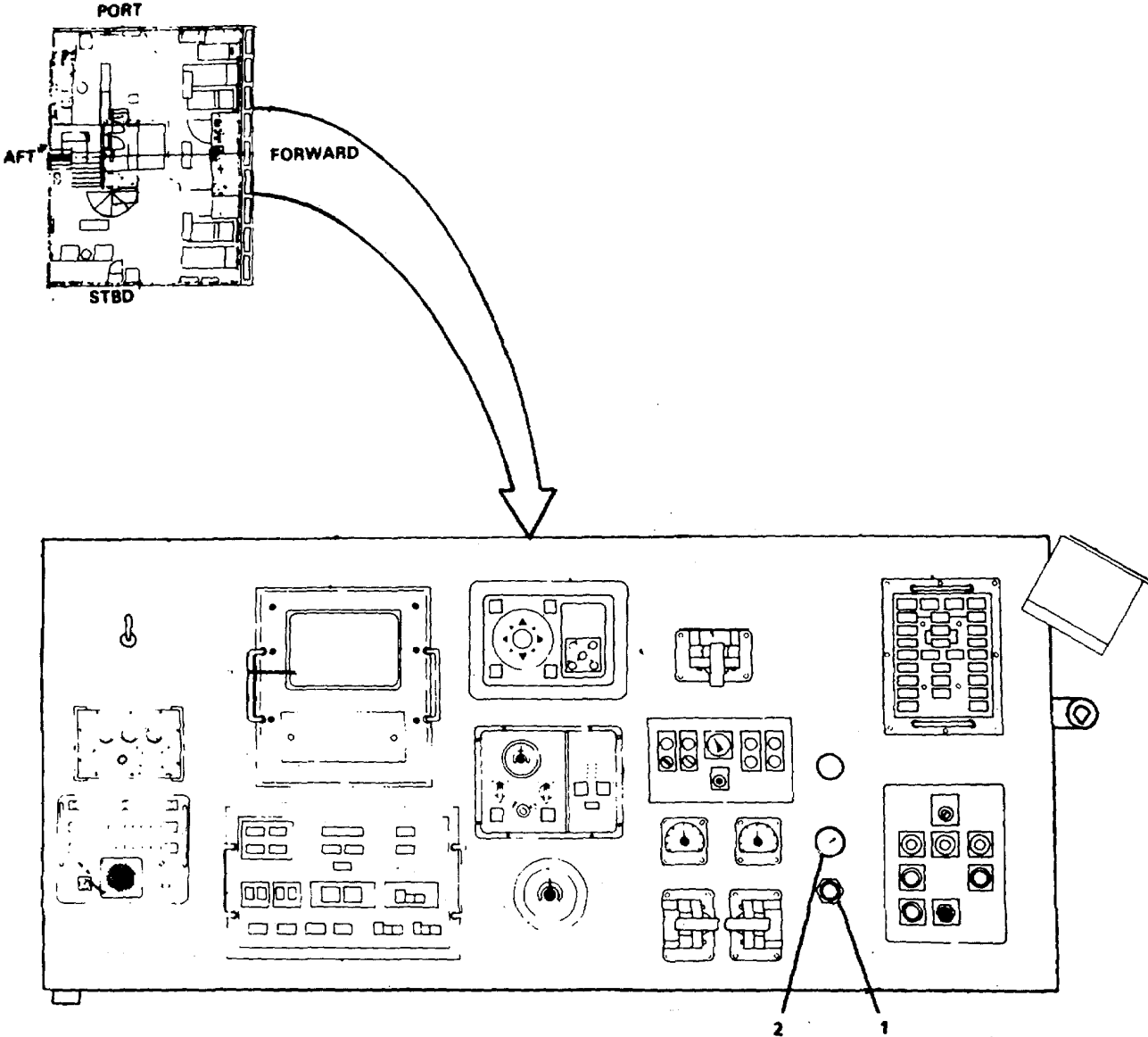

- LEGEND**
- 1. CONTROL AIR STATION TRANSFER VALVE
  - 2. TRANSFER AIR PRESSURE

FIGURE 2-188. Pilothouse Console.

**2-24. Sound Powered Telephone System****NOTE**

There are four models of sound powered telephones used on LCU. Models SER (FIGURE 2-189), SELR (FIGURE 2-190), SFLR (FIGURE 2-191), and MWT-R (FIGURE 2-192), all operate in the same way and an overall method of operation will be used. There is also a Sound Powered Head Set-Chest Set used on LCU and it will be covered separately.

a. Answering a call.

- (1) Pick up HANDSET (1, FIGURE 2-191) and press HANDSET pushbutton (7) in middle of handset to answer call.
- (2) Release HANDSET pushbutton (7) to allow calling party to talk.

**NOTE**

The handset pushbutton will cut out receive portion of handset and instructions will not be heard.

b. Placing a call.

- (1) Turn SELECTOR KNOB (3, FIGURE 2-191) to desired station number on SELECTOR DIAL (4).
- (2) Turn MAGNETO HANDLE (2) clockwise 3 or 4 times. This will signal the station being called.
- (3) Pick up HANDSET (1) and wait for answer on receive portion of the handset.
- (4) Operate HANDSET pushbutton (7, FIGURE 2-176) to pass information, release HANDSET pushbutton (7) to hear other party.

c. Audible Devices and Light Operation.**NOTE**

In noisy spaces such as engine room, emergency generator room, and bowthruster compartment, sound powered telephones have audible and light indicators to attract attention.

- (1) On Model SELR (FIGURE 2-190) INDICATOR LIGHT (1) will light with calling signal. When HANDSET (2) is raised the INDICATOR LIGHT (1) will go out.
- (2) On Model SFLR (FIGURE 2-191) INDICATOR LIGHT (6) will light with calling signal. When telephone is answered, press RESET BUTTON (5) to put INDICATOR LIGHT (6) out and prepare telephone for next call.

d. Head Set-Chest Set Operation.

- (1) Remove Head Set-Chest Set from storage box.

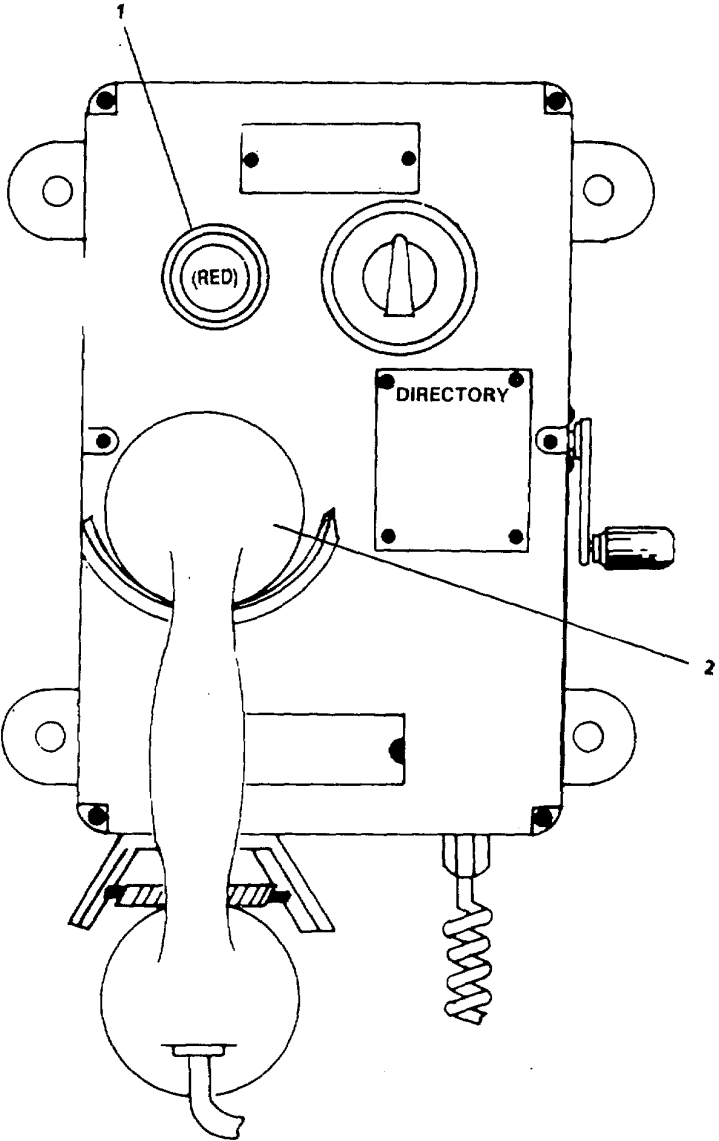

- LEGEND**  
1. INDICATOR LIGHT  
2. HANDSET

FIGURE 2-189. Sound Powered Telephone Model SER.

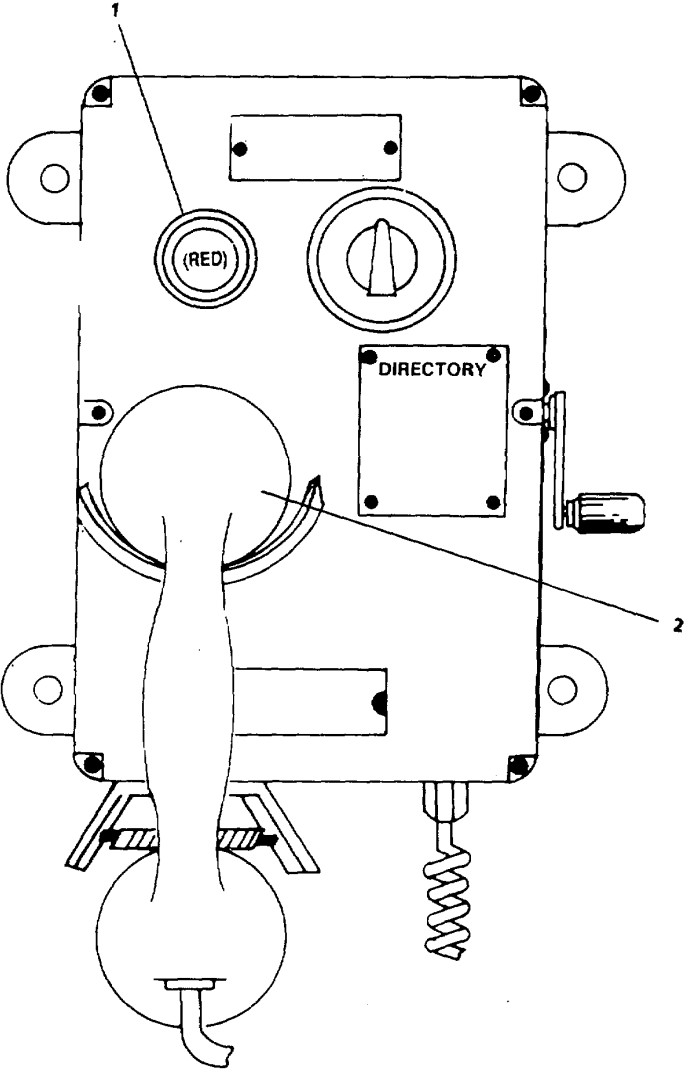

- LEGEND**  
1. INDICATOR LIGHT  
2. HANDSET

FIGURE 2-190. Sound Powered Telephone Model SELR.



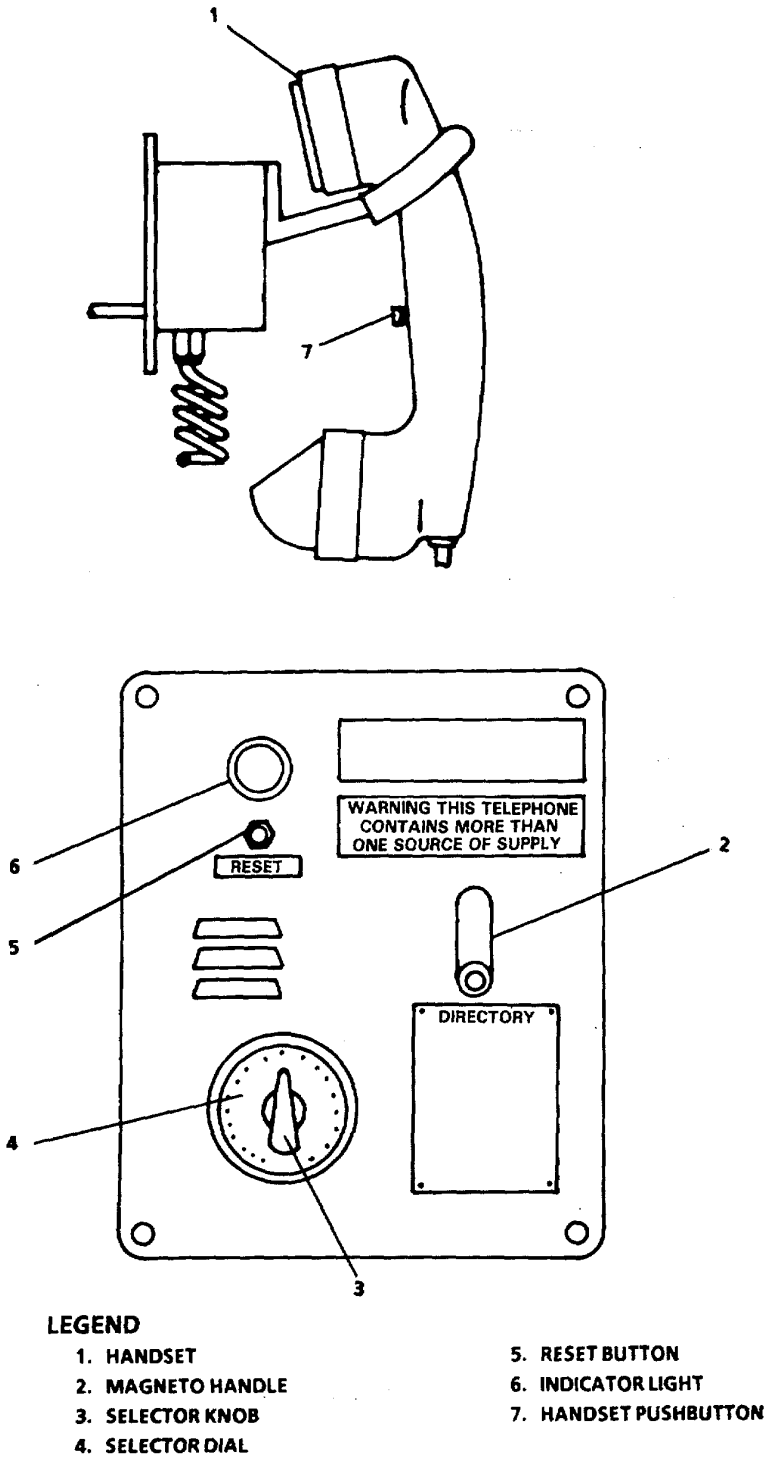
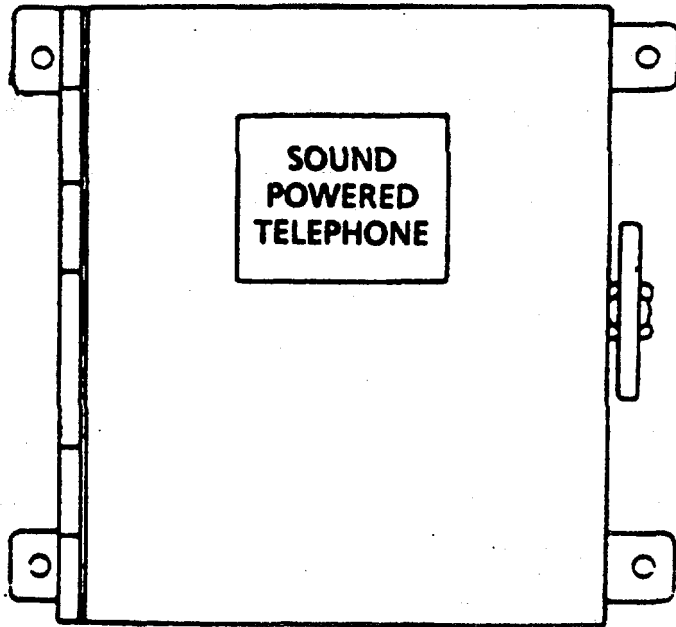
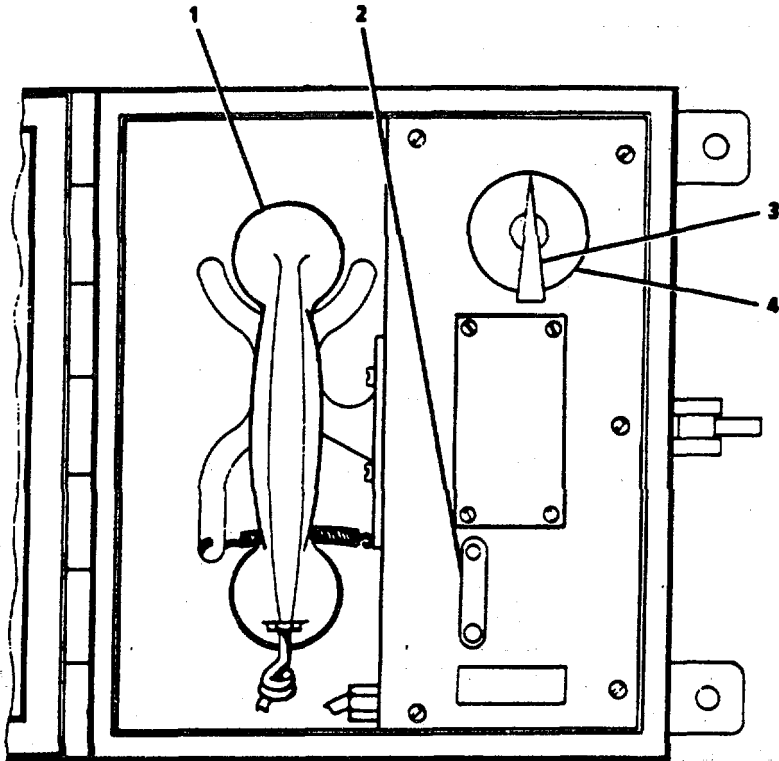

FIGURE 2-191. Sound Powered Telephone Model SFLR.



**LEGEND**

- 1. HANDSET
- 2. MAGNETO HANDLE
- 3. SELECTOR KNOB
- 4. SELECTOR DIAL

FIGURE 2-192. Sound Powered Telephone Model MWT-R.  
2-529

- (2) Remove JACK COVER (8, FIGURE 2-193) by turning counterclockwise.
- (3) Insert JACK PLUG (6) into socket.
- (4) Disconnect HOOK (1) from SUPPORT BRACKET (5). Place strap around neck and reconnect HOOK (1).
- (5) Place HEADSET (4) over head with ear cups covering ears.
- (6) Adjust MOUTHPIECE (2) 3 inches in front of mouth and 2 inches below your lips.
- (7) Press Push Button (3) located on top of mouthpiece to answer instructions or pass information.

**NOTE**

The head set will receive the other party even when push button is pressed.

- (8) When instructions have been finished and are advised to discontinue operation, remove HEADSET (4) and place around SUPPORT BRACKET (5). Disconnect HOOK (1) from SUPPORT BRACKET (5), remove strap from around neck and reconnect HOOK (1).
- (9) Disconnect JACK PLUG (6) from TELEPHONE JACK BOX (7) and replace JACK COVER (8) by turning clockwise to keep it waterproof.
- (10) Replace Head Set-Chest Set in storage box and fasten cover.

**2-25. Intercom (LS-519A) Operation.**

a. Answering a call.

- (1) When call is received on LS-519A (FIGURE 2-194), your compartment name will be called.
- (2) To answer turn down and hold INTERCOM CONTROL lever (2) to PRESS TO TALK position, speak into the LS-519A directly, and acknowledge call by giving your name and release the INTERCOM CONTROL lever (2).
- (3) Each time you answer or pass information you must-turn down and hold INTERCOM CONTROL lever (2) to PRESS TO TALK position.
- (4) Adjust VOLUME CONTROL (4) to desired level during time other party is speaking.

b. Placing a call.

- (1) Press STATION Push Button (1, FIGURE 2-194) of desired station to be called.
- (2) Turn down and hold INTERCOM CONTROL lever (2) to PRESS TO TALK, and call station; release INTERCOM CONTROL lever (2) to hear answer.

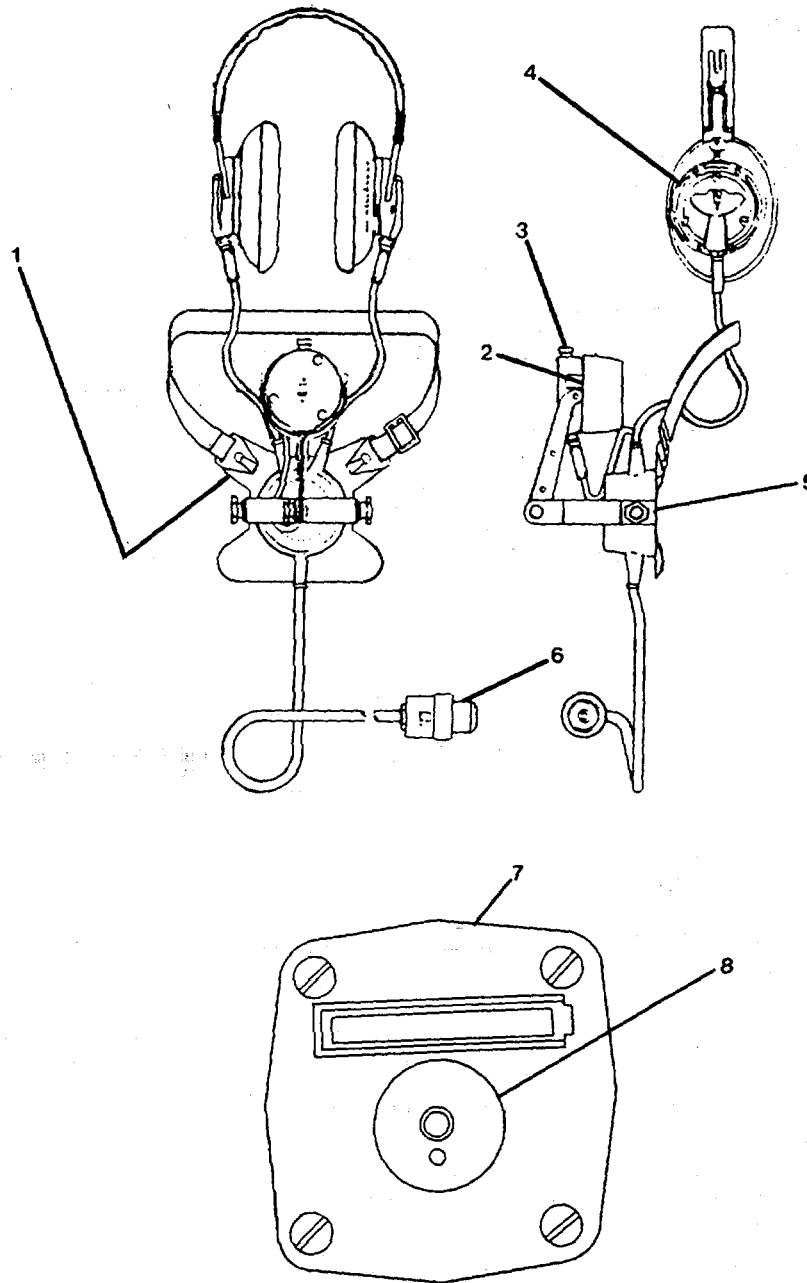

**LEGEND**

- |               |                       |
|---------------|-----------------------|
| 1. HOOK       | 5. SUPPORT BRACKET    |
| 2. MOUTHPIECE | 6. JACK PLUG          |
| 3. PUSHBUTTON | 7. TELEPHONE JACK BOX |
| 4. HEADSET    | 8. JACK COVER         |

FIGURE 2-193. Head Set-Chest Set.

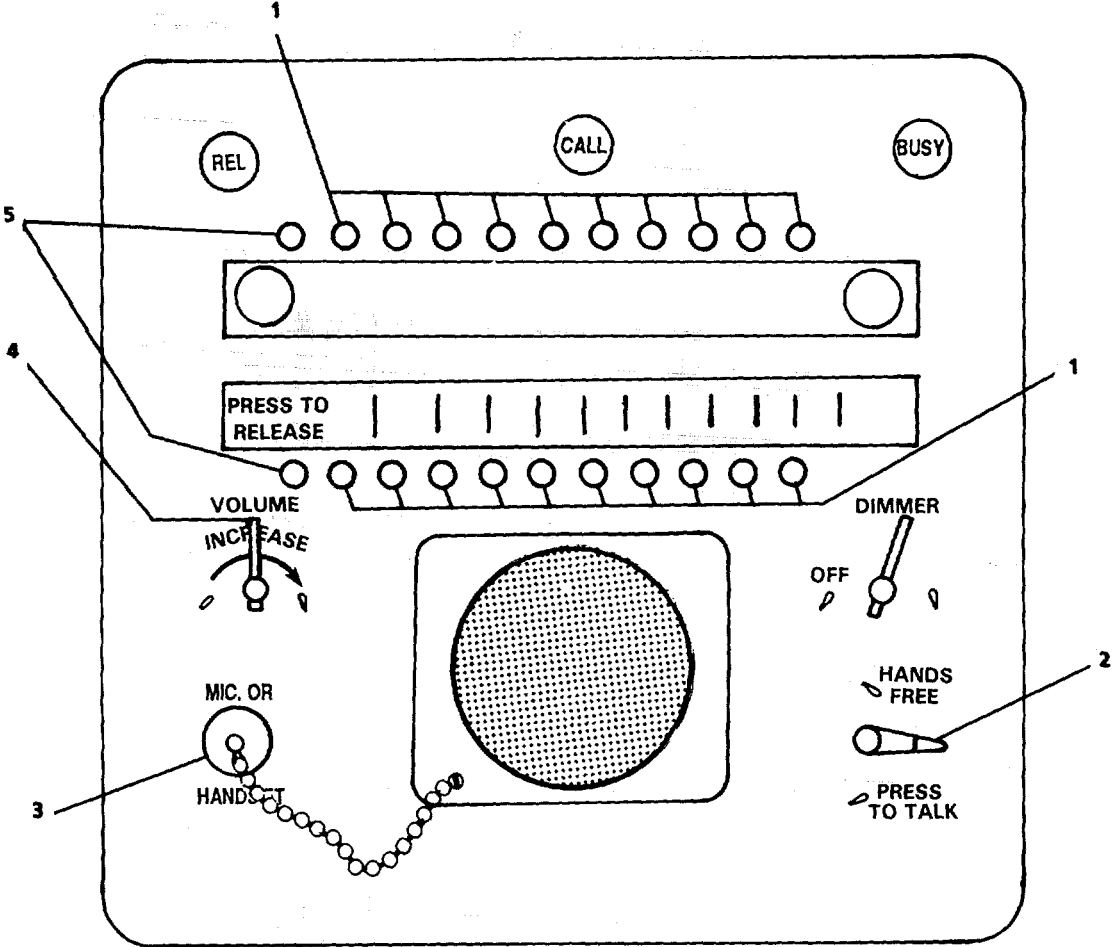

**LEGEND**

- 1. STATION PUSHBUTTON
- 2. INTERCOM CONTROL
- 3. MIC OR HANDSET
- 4. VOLUME CONTROL
- 5. PRESS TO RELEASE

FIGURE 2-194. LS-519A Panel.

(3) When call is finished press PRESS TO RELEASE pushbutton (5) on row station pushbutton was in.

c. Making an Announcement.

(1) Press STATION pushbuttons (1) of selected stations or all stations.

(2) Turn up INTERCOM CONTROL lever (2) to HANDS FREE position.

(3) To make the announcement with a microphone do following:

(a) Turn cover counterclockwise on MIC. OR HANDSET socket (3) and remove.

(b) Connect a microphone plug to socket (3).

**NOTE**

If announcement is made without a microphone, speak directly into LS-519A.

(4) Make announcement.

(5) When announcement is finished turn down INTERCOM CONTROL lever (2) to center position.

(6) Press PRESS TO RELEASE pushbutton (5) on row stations pushbuttons were on.

**NOTE**

If microphone was used, remove microphone plug and secure socket cover.

**2-26. Bench Grinder (FIGURE 2-195).****CAUTION**

- Keep guards in place and in working order.
  - Remove adjusting keys and wrenches. Form a habit of checking these items are removed from the grinder before turning it on.
  - Keep work area clean.
  - Avoid a dangerous environment. Do not use power tools in a wet location. Keep work area well lit.
  - Use right tool. Do not force tools or attachments to do a job for which they are not designed.
  - Wear appropriate apparel. Do not wear loose clothing or jewelry, which can get caught in moving parts. Rubber-soled footwear is recommended for best footing.
  - Use safety glasses.
  - Secure material. Use clamps or a vise -to hold work at all times.
  - Do not overreach. Keep proper footing and balance at all times.
  - Disconnect tools before servicing.
  - Avoid accidental starting. Ensure-switch is in OFF position
  - before plugging in.
  - Use only recommended accessories.
  - Check for damaged parts before using.
- a. Check that ON-OFF switch (4) is in OFF position and that GRINDER WHEEL (2) rotates freely.
  - b. Check that EYE SHIELD (1) is in place.
  - c. Check that TOOL REST (3) has-1/16 inch clearance from GRINDER WHEEL (2).
  - d. Set ON-OFF switch (4) to ON position.

**NOTE**

Allow grinder to reach full running speed before starting to grind.

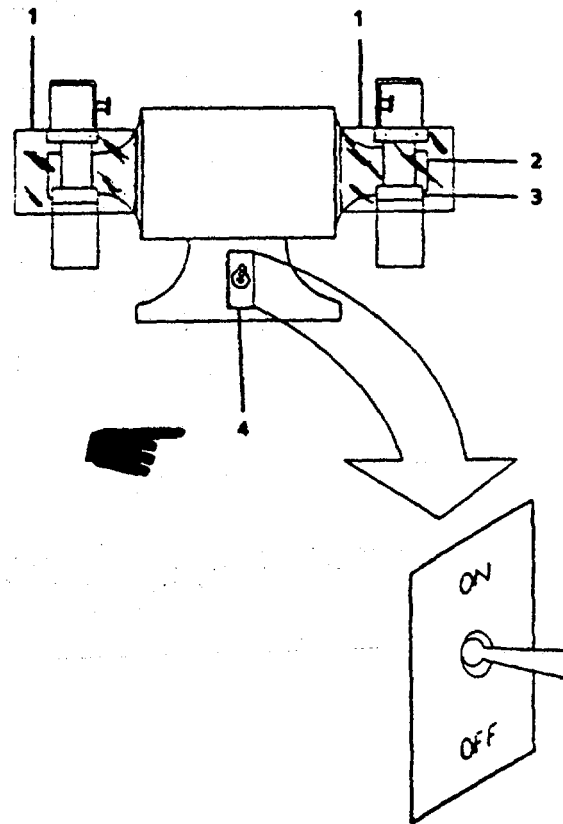

**LEGEND**

- 1. EYESHIELD
- 2. GRINDER WHEEL

- 3. TOOL REST
- 4. ON-OFF SWITCH

FIGURE 2-195. Bench Grinder.

Change 1 2-535



- e. Hold the piece being ground firmly against the wheel with a light but steady pressure.

**CAUTION**

Excessive or sudden pressure slows grinding action, overloads the motor and puts dangerous stresses on wheel, besides gouging wheel and causing rough grinding with reduced accuracy.

- f. Keep TOOL REST (3). adjusted to within 1/16 inch of GRINDER WHEEL (2).  
g. When job is finished, set ON-OFF switch (4) to OFF position.

**2-27. Electric Welding Machine (FIGURE 2-196).**

**WARNING**

- Electric shock can kill. Do not touch live electrical parts or electrodes.
- Always wear protective clothing (welding coat and gloves) and eye protection (filter glasses and/or welding helmet). Failure to comply may result in serious personal injury.
- Do not work with wet gloves or wet clothing.
- Fumes and gasses can cause severe discomfort, illness, or death. Keep your head out of the fumes. Ventilate work site or use an exhaust duct at arc. Otherwise use an air supplied respirator. Stop work at first signs of dizziness, nausea or respiratory irritation and correct problem. Never ventilate work area with oxygen. Do not use an oxygen respirator.
- Wear ear plugs to protect ears from sparks.
- The use of damaged or defective equipment can be hazardous. Replace worn, broken, distorted, missing, or contaminated parts immediately. Refer to unit maintenance.

a. Shielded Metal-Arc Welding (SMAW).

- (1) Make all necessary cable connections for shielded metal-arc welding (SMAW).
- (2) Set CONTACTOR control switch (5) to LOCAL or REMOTE position.
- (3) Set POLARITY switch (48) in desired position.
- (4) If remote amperage control is used, set the CURRENT CONTROL switch (4) to REMOTE position.

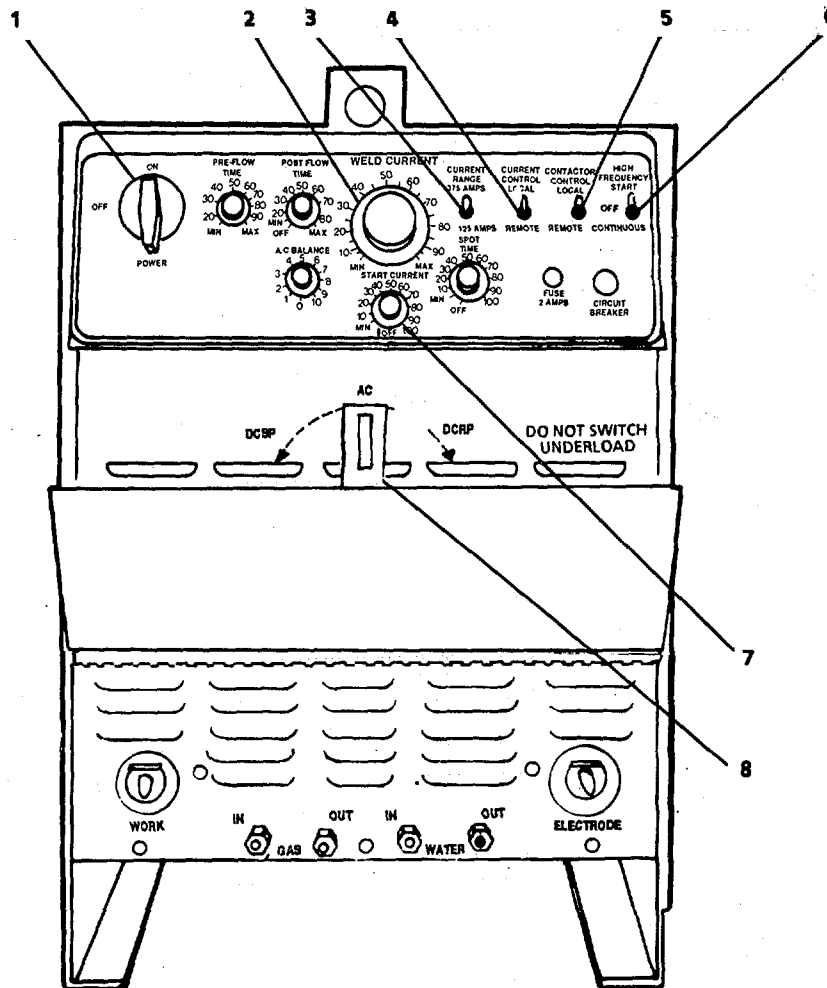

**LEGEND**

- |                                |                             |
|--------------------------------|-----------------------------|
| 1. POWER SWITCH                | 5. CONTACTOR CONTROL SWITCH |
| 2. WELD CURRENT CONTROL SWITCH | 6. HIGH FREQUENCY SWITCH    |
| 3. CURRENT RANGE SWITCH        | 7. START CURRENT SELECTOR   |
| 4. CURRENT CONTROL SWITCH      | 8. POLARITY SWITCH          |

FIGURE 2-196. Electric Welding Machine.

- (5) If remote amperage control is not used, set the CURRENT CONTROL switch (4) to the LOCAL position.
- (6) Set the CURRENT RANGE switch (3) in the desired position.
- (7) Rotate the WELD CURRENT CONTROL switch (2) to the desired position.
- (8) Set the HIGH-FREQUENCY switch (6) to OFF position.
- (9) Set START CURRENT selector (7) to OFF position.
- (10) Set POWER switch (1) to ON position.
- (11) Start welding.

b. Shutdown

**WARNING**

When welding is performed in confined area, failure to turn off shield gas supply could result in buildup of gas fumes and displacement of oxygen, endangering personnel within and entering welding area.

- (1) Break arc and allow welding machine to idle for 3 minutes with no load applied.
- (2) Set POWER switch (1) in OFF position.

**2-28. Rotary Window Wipers**

a. Operate Rotary Window Wipers To operate the rotary window wipers perform the following:

- (1) On Emergency Switchboard (FIGURE 2-197):
  - (a) Set MAIN SWBD BUS TIE circuit breaker (2) to ON position.
  - (b) Set WHL/HSE EMG LTG PNL circuit breaker (1) to ON position.
- (2) In Pilothouse, on EL-102 panel set CLEARVIEW SCREEN HTR circuit breaker 14 to ON position.
- (3) On CLEARVIEW SCREEN (FIGURE 2-198) switchbox, select window wiper as required: Port, Center or Starboard.
  - (a) If Port window wiper is selected, set PORT SPIN ON/OFF switch (1) to ON position.
  - (b) If Center window wiper is selected, set CTR SPIN ON/OFF switch (6) to ON position.
  - (c) If Starboard window wiper is selected, set STBD SPIN ON/OFF switch (5) to ON position.

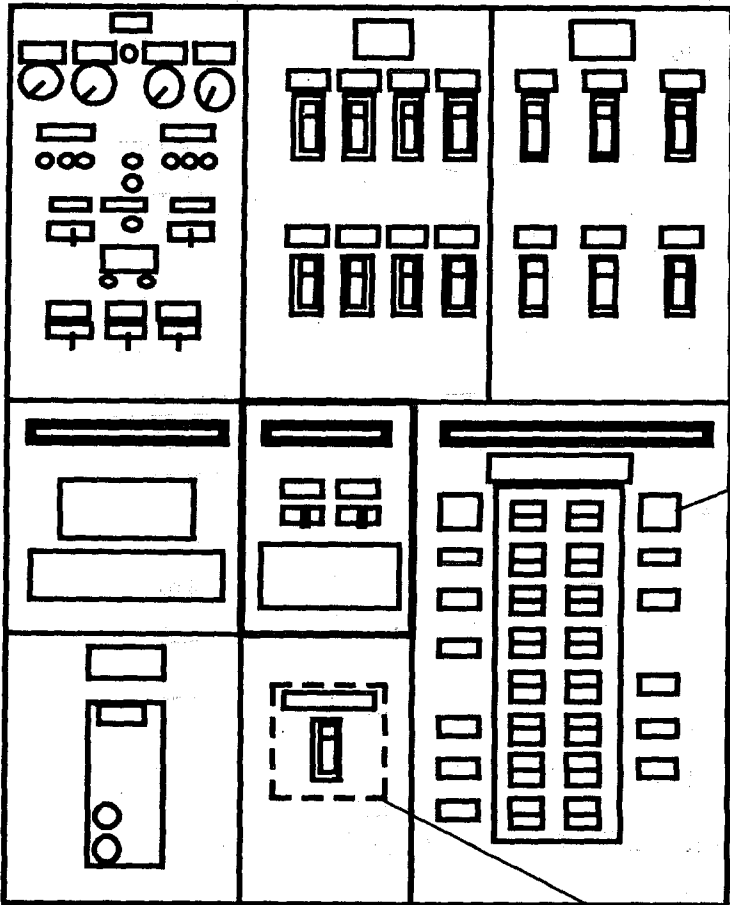

**LEGEND**

- 1. WHL/HSE EMG LTG PNL
- 2. MAIN SWBD BUS TIE

FIGURE 2-197. Emergency Switchboard.

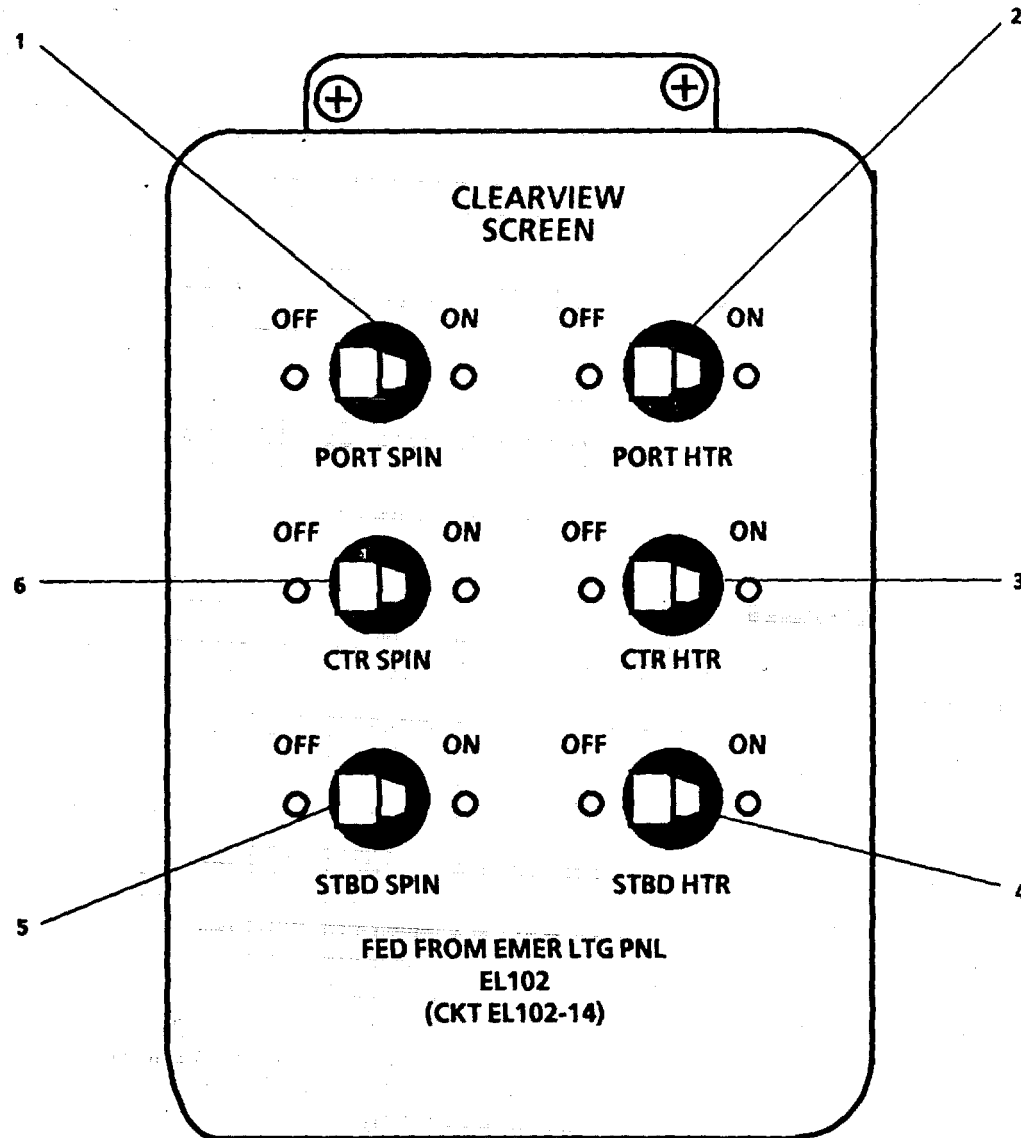

**LEGEND**

- 1. PORT SPIN ON/OFF SWITCH
- 2. PORT HTR ON/OFF SWITCH
- 3. CRT HTR ON/OFF SWITCH
- 4. STBD HTR ON/OFF SWITCH
- 5. STBD SPIN ON/OFF SWITCH
- 6. CTR SPIN ON/OFF SWITCH

FIGURE 2-198. Clearview Screen Pilohouse Windows Wiper and Heater.

**NOTE**

If the windows are foggy or are icing up, on CLEARVIEW SCREEN switchbox, set PORT HTR, CTR HTR, and STBD HTR ON/OFF switches (2, 3, and 4) to ON positions.

b. Turn Off Rotary Window Wipers To turn off rotary window wipers, perform the following:

- (1) On CLEARVIEW SCREEN switchbox, select window wiper to be turned off: Port, Center or Starboard.
  - (a) If Port is to be turned off, set PORT SPIN ON/OFF switch (1) to OFF position.
  - (b) If Center is to be turned off, set CTR SPIN ON/OFF switch (6) to OFF position.
  - (c) If starboard is to be turned off, set STBD SPIN ON/OFF switch (5) to OFF position.
- (2) On the CLEARVIEW SCREEN switchbox, set the PORT HTR, CTR HTR, and STBD HTR ON/OFF switches (2, 3, and 4) to OFF positions.
- (3) In Pilothouse on EL-102 panel, set CLEARVIEW SCREEN HTR circuit breaker 14 to OFF position.

**2-29. Watertight Hatch Operation** All hatches that open onto a weather deck are watertight. To secure watertight condition secure all dogs on each hatch.

**2-30. 500 WATT XENON Searchlight****WARNING**

- High pressures exist inside lamp, especially when hot, and under certain conditions it could explode. Handle lamp only in its protective cover.
- Remove protective cover from lamp before energizing circuits. Protect the eyes and wear gloves when removing cover from lamp. An industrial type face mask is recommended for eye and face protection.
- Avoid direct exposure from powerful direct and reflected radiations given off by lamp. The front cover glass provides protection from these radiations.
- Do not stand close in front of searchlight front cover glass when lamp is lighted. In the event of lamp explosion the front cover glass could break causing serious personal injury.

**CAUTION**

Operation of lamp with finger marks or grease on the surface will cause deterioration of the quartz arc tube.

a. Lighting Lamp (FIGURE 2-199).

- (1) Remove protective cover from lamp.
- (2) In Pilothouse on EL-102 panel, set 500W XENON SCHLT (PORT) and 500 XENON SCHLT (STBD) circuit breakers 4 and 5 to ON position.
- (3) In Pilothouse, turn ON-OFF-RESET switch (3, FIGURE 2-199) counterclockwise to ON position.
- (4) Set STANDBY-OFF switch (6) to STANDBY position.
- (5) Turn searchlight OFF-START switch (5) clockwise to START position; hold until lamp lights.

**NOTE**

Do not hold switch in start position any longer than necessary to start lamp.

b. Directing Beam

- (1) Twist to left HORIZONTAL LOCK (9).
- (2) Point LEVER HANDLE (8) in desired direction.
- (3) Twist to right HORIZONTAL LOCK (9) to lock horizontal position.
- (4) Twist to left VERTICAL LOCK KNOB (7) to unlock vertical position.
- (5) Twist LEVER HANDLE (8) to the right for beam to go up, to the left for beam to go down.
- (6) Twist to the right VERTICAL LOCK KNOB (7) to lock vertical position.

**NOTE**

If searchlight is to be moved constantly do not lock the horizontal or vertical locks.

c. Focusing Beam in Pilothouse

- (1) On top of searchlight drum, ensure LOCK KNOB (2) on the MANUAL FOCUS KNOB (1) is unlocked.
- (2) In Pilothouse on BEAM FOCUS switch (4), adjust BEAM FOCUS switch (4) to BEAM or FOCUS position to adjust diameter of beam and intensity.
- (3) Release BEAM FOCUS switch (4).

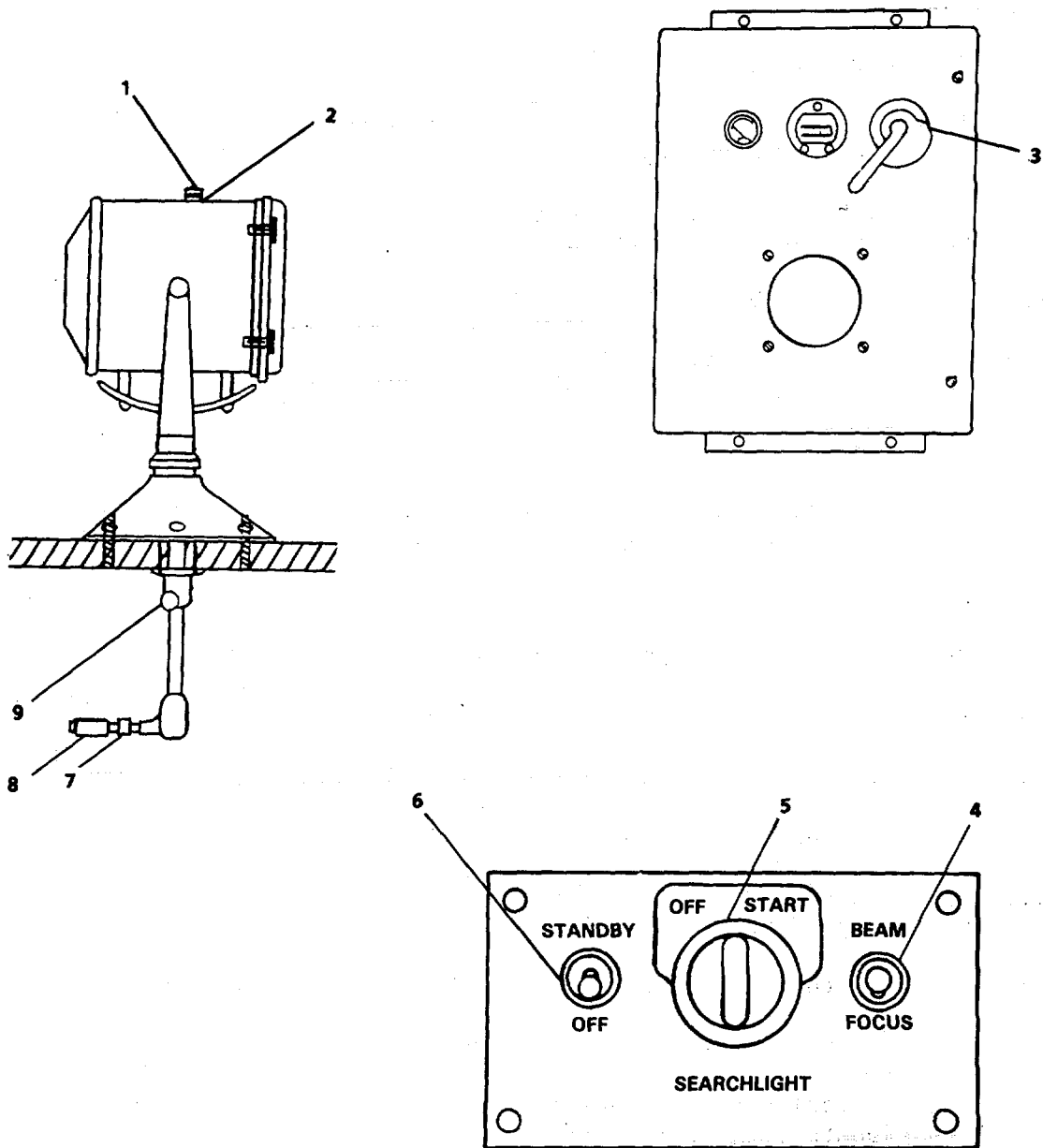

**LEGEND**

- |                        |                       |
|------------------------|-----------------------|
| 1. MANUAL FOCUS KNOB   | 6. STANDBY-OFF SWITCH |
| 2. LOCK KNOB           | 7. VERTICAL LOCK KNOB |
| 3. ON-OFF-RESET SWITCH | 8. LEVER HANDLE       |
| 4. BEAM FOCUS SWITCH   | 9. HORIZONTAL LOCK    |
| 5. OFF-START SWITCH    |                       |

FIGURE 2-199. 500 Watt XENON Searchlight.



d. Focusing Beam From Searchlight Drum**WARNING**

- High pressures exist inside lamp, especially when hot, and under certain conditions it could explode. Handle lamp only in its protective cover.
- Avoid direct exposure from powerful direct and reflected radiations given off by lamp. The front cover glass provides protection from these radiations.
- Do not stand close in front of searchlight front cover glass when lamp is lighted. In the event of lamp explosion the front cover glass could break and cause serious personal injury.
- Searchlight drum gets hot after lamp has been burning for a short time. Avoid bodily contact with drum and wear gloves when handling focus knob.

(1) On top of searchlight drum twist to the left LOCK KNOB (2) to release it.

(2) Turn MANUAL FOCUS KNOB (1) either clockwise or counterclockwise to adjust diameter of beam and its intensity.

(3) Twist LOCK KNOB (2) to lock FOCUS KNOB (1).

e. Shutdown.

- (1) If searchlight is to be used again within the hour, turn OFF-START SEARCHLIGHT switch (5) clockwise to OFF position.
- (2) If searchlight will not be used for several hours, turn searchlight OFF- START SEARCHLIGHT switch (5) clockwise to OFF position, set STANDBY-OFF switch (6) to OFF position, and ON-OFF-RESET switch (3) to OFF position.

**2-31. Portable Fire Pump**a. Suction and Discharge Hose Attachment

- (1) Unscrew and remove caps (FIGURE 2-200) from water suction (2) and water discharge (1) openings.
- (2) Connect suction hose fitting to suction coupling and place suction hose with foot valve and strainer into water supply.
- (3) Connect discharge hose fitting to discharge coupling. Ensure discharge hose is manned.

## b. Automatic Priming Startup.

- (1) Clear discharge port of priming pump.

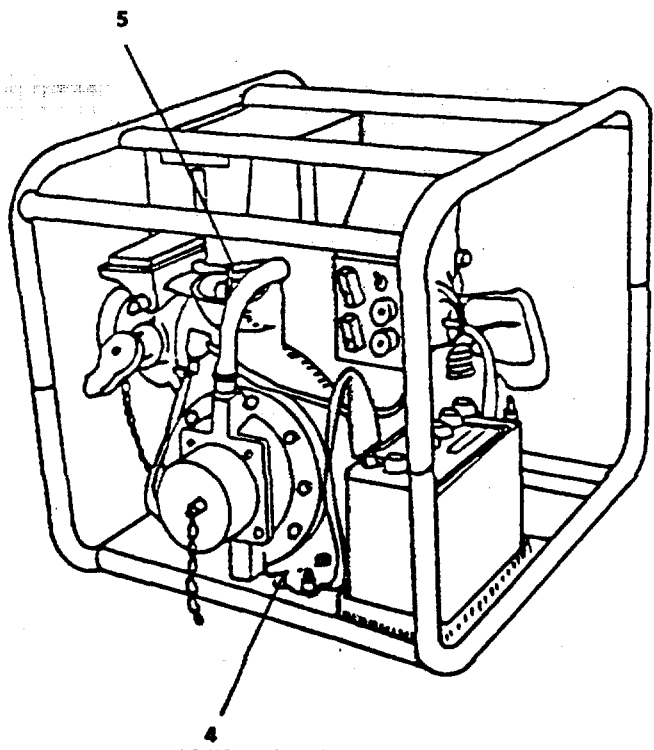
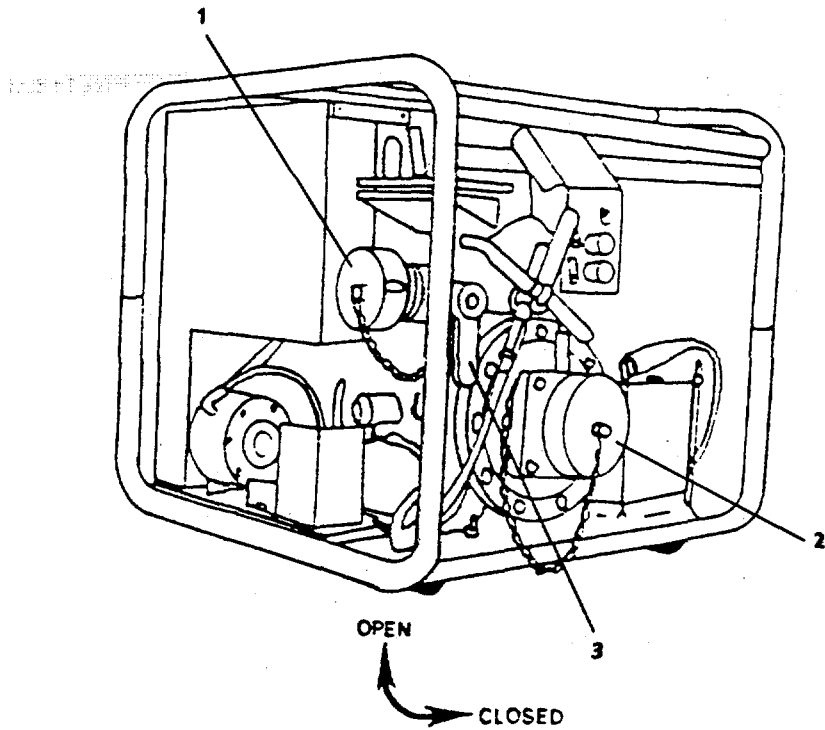

- LEGEND**
- |                    |                |
|--------------------|----------------|
| 1. DISCHARGE CAP   | 4. DRAIN VALVE |
| 2. SUCTION CAP     | 5. INLET PLUG  |
| 3. DISCHARGE VALVE |                |

FIGURE 2-200. Portable Firefighting Pump, Gasoline Engine Driven.

- (2) Connect red battery cable to (+) positive pole next to carburetor and black cable to (-) negative pole next to main pump suction inlet.
- (3) Place OFF-START-RUN switch (2, FIGURE 2-201) in start position.
- (4) Advance SPEED control (6) in clockwise direction, to one quarter of full throttle.

**NOTE**

If engine is cold, advance CHOKE control (5) fully clockwise (closed), then half open as engine starts, as engine warms-up fully open choke for running.

- (5) Press and hold START pushbutton (4) until engine starts. Adjust choke and speed controls as required.

**CAUTION**

Do not allow pump to run more than 2 minutes without water flowing. Lack of cooling water could cause severe impeller and exhaust system damage.

- (6) Turn water discharge valve (3, FIGURE 2-200) counterclockwise to fully CLOSED position.

**NOTE**

If suction lift is 20 feet or less, push in and keep firm continuous pressure on PRIME pushbutton until pump is primed.

- (7) Push in PRIME pushbutton (3, FIGURE 2-201) until pump is primed.
- (8) Slowly turn water discharge valve (3, FIGURE 2-200) clockwise until indicating pressure on gauge (1, FIGURE 2-201) and advance speed control (6) as required.
- (9) Release PRIME pushbutton (3) after priming pump.
- (10) Place OFF-START-RUN switch (2) in RUN position.
- (11) Rotate CHOKE control (5) to full counterclockwise, OFF position.

c. Manual Priming Startup

- (1) Unscrew and remove manual prime inlet plug (5, FIGURE 2-200) from priming inlet.
- (2) Fill pump with water until filler cap is full, replace plug in priming inlet.
- (3) Place OFF-START-RUN switch (2, FIGURE 2-201) to START position.
- (4) Advance SPEED control (6) in clockwise direction, 1/4 full throttle.

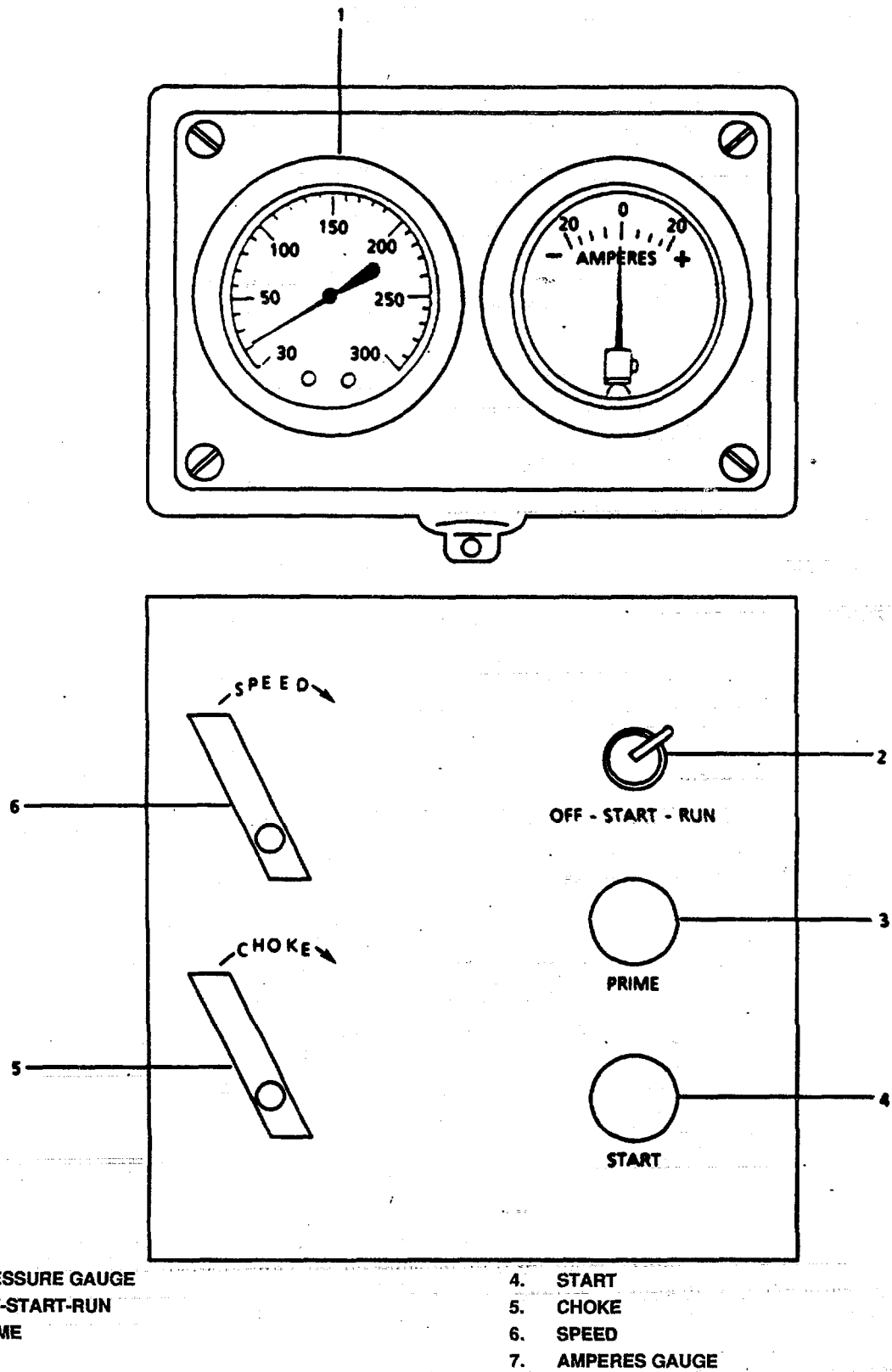

FIGURE 2-201. Portable Firefighting Pump. Gasoline Engine Driven.

**NOTE**

If engine is cold, advance CHOKE control (5) fully clockwise (closed), then half open as engine starts, and fully open for running.

- (5) Press and hold START Push Button (4) until engine starts. Adjust choke and speed controls as required.

**CAUTION**

Do not allow pump to run more than 2 minutes without water flowing. Lack of cooling water could cause severe impeller and exhaust system damage.

- (6) Open water discharge valve (3, FIGURE 2-200) slowly and advance engine SPEED control (6, FIGURE 2-201) as required to attain desired pumping pressure.
- (7) Place OFF-START-RUN switch (2) in RUN position.
- (8) Rotate CHOKE control (5) to full counterclockwise position.

d. Shutdown Procedures

- (1) Rotate SPEED control (6, FIGURE 2-201) to full counterclockwise idle position.
- (2) Place OFF-START-RUN switch (2) in OFF position.
- (3) Open pump drain valve (4, FIGURE 2-200) fully counterclockwise. Keep open until drained.
- (4) Flush pump with fresh water.
  - (a) Place suction hose with foot valve and strainer into fresh water supply.
  - (b) Prime pump until full, inspect for leaks.
  - (c) Shut discharge valve.

**WARNING**

Ensure exhaust gases discharge to outside atmosphere.

- (d) Start engine. Switch to start; advance speed slightly; press start button; choke as needed.
- (e) Prime pump; push priming buttons and hold, when water discharges from priming pump; ensure discharge hose is manned; open water discharge valve slowly. Release priming button.

**NOTE**

Primer pump should evacuate air from impeller housing and suction hose in approximately 60 seconds.

**CAUTION**

Do not operate pump more than 2 minutes unless pressure shows on gauge or priming pump discharges water.

- (f) Operate pump; switch to run; adjust engine speed to obtain desired discharge pressure.
- (g) Operate pump for 1 minute; inspect for leaks, unusual noises and vibrations.
- (h) Slow engine speed to idle and push primer button; observe discharge at primer pump; allow primer pump to run for 30 to 45 seconds to flush out; release primer button.
- (i) Shut discharge valve.
- (j) Stop engine by disconnecting fuel hose and allowing engine to run until excess fuel is burned off.
- (k) Depressurize and remove fuel tank.
- (l) Check oil level in priming pump oiler; fill if necessary. Switch engine control to OFF position, then push both starter and priming buttons to oil priming for storage. Hold both buttons for approximately 5 seconds. Release buttons.
- (m) Disconnect hoses and fitting.
- (n) Drain pump by opening pump drain valve fully counterclockwise.
- (o) Dry unit, replace caps on all openings; close pump drain valve.
- (p) Stow pump hoses and connectors.

e. Manual Startup with Automatic Priming

- (1) Clear discharge port of priming pump.
- (2) Connect red battery cable to (+) positive pole next to carburetor and black cable to (-) negative pole next to main pump suction inlet.
- (3) Place OFF-START-RUN switch (2, FIGURE 2-201) in start position.
- (4) Advance SPEED control (6) clockwise direction, to one quarter of full throttle.

**NOTE**

If engine is cold, advance CHOKE control (5) fully clockwise (closed), then half open as engine starts, and fully open for running.

- (5) Pull manual start pull cord (1, FIGURE 2-202) in a quick steady motion until engine starts.

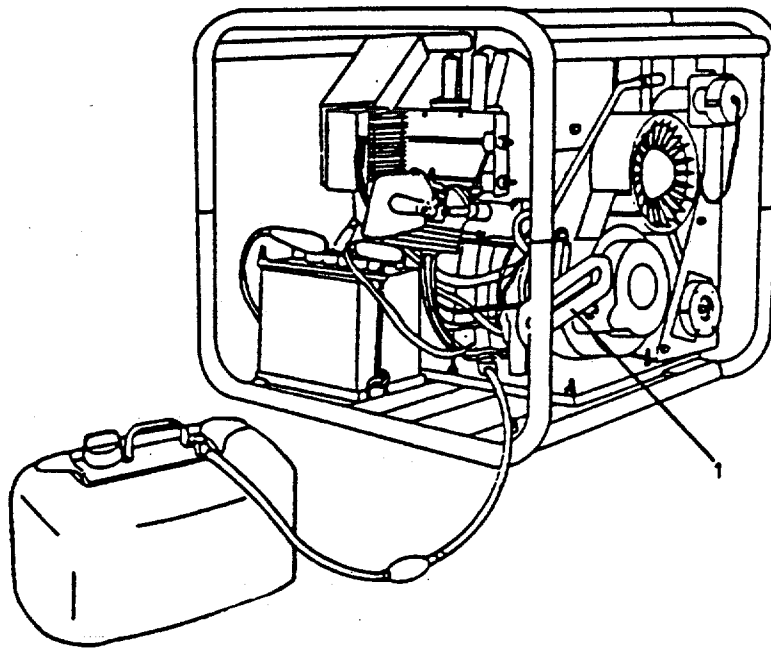
**LEGEND**

1. MANUAL START PULL CORD

FIGURE 2-202. Portable Firefighting Pump Manual Start.

**CAUTION**

Do not allow pump to run more than 2 minutes without water flowing. Lack of cooling water could cause severe impeller and exhaust system damage.

- (6) Turn water discharge valve (3, FIGURE 2-200) counterclockwise to fully CLOSED position.

**NOTE**

If suction lift is 20 feet or less, push in and keep firm continuous pressure on PRIME pushbutton until pump is primed.

- (7) Push in PRIME pushbutton (3, FIGURE 2-201) until pump is primed.
- (8) Slowly turn water discharge valve (3, FIGURE 2-200) clockwise until indicating pressure on gauge (1, FIGURE 2-201) and advance SPEED control (6) as required.
- (9) Release PRIME pushbutton (3) after priming pump.
- (10) Place OFF-START-RUN switch (2, FIGURE 2-201) in RUN position.

(11) Rotate CHOKE control (5) to full counterclockwise, OFF position.

f. Manual Startup With Manual Priming

(1) Unscrew and remove INLET PLUG (5, FIGURE 2-200) from priming inlet.

(2) Fill pump with water until filler inlet is full, replace plug (5) in filler inlet.

(3) Connect red battery cable to (+) positive pole next to carburetor and black cable to (-) negative pole next to main pump suction inlet.

(4) Place OFF-START-RUN switch (2, FIGURE 2-201) in start position.

(5) Advanced SPEED control (6) clockwise direction, to one quarter of full throttle.

**NOTE**

If engine is cold, advance CHOKE control (5) fully clockwise (closed), then half open as engine starts, and fully open for running.

(6) Pull manual start pull cord (1, FIGURE 2-202) in a quick steady motion until engine starts.

**CAUTION**

Do not allow pump to run more than 2 minutes without water flowing. Lack of cooling water could cause severe impeller and exhaust system damage.

(7) Slowly turn water discharge valve (3, FIGURE 2-200) clockwise until indicating pressure on gauge (1, FIGURE 2-201) and advance speed control (6) as required.

(8) Rotate CHOKE control (5) to full counterclockwise, OFF position.

**2-32. Commissary Equipment**

a. Dishwasher (FIGURE 2-203)

**CAUTION**

Do not attempt to operate without wash tank being properly filled. Dry rotation will damage motor seals.

(1) Open door.

(2) Press main ON-OFF switch (2) to ON position.

(3) Close door.

(4) Press and hold START-FILL switch (1) in FILL position for 50 seconds or until water can be heard flowing down drain.



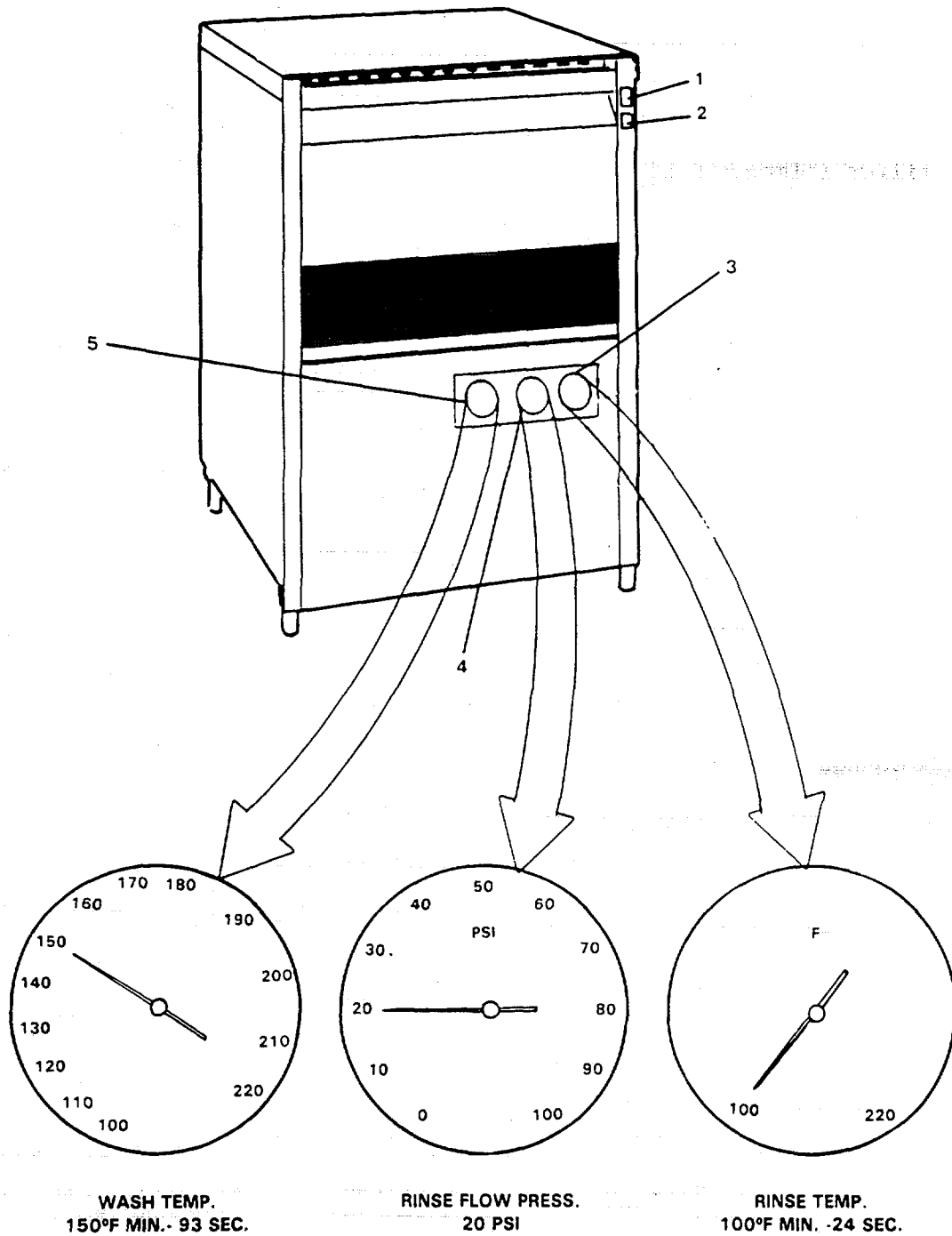

**LEGEND**

- 1. START/FILL SWITCH
- 2. MAIN ON/OFF SWITCH
- 3. FINAL RINSE TEMPERATURE GAUGE
- 4. FINAL RINSE PRESSURE GAUGE
- 5. WASH TANK TEMPERATURE GAUGE

FIGURE 2-203. Dishwasher.

- (5) Open door and insert properly pre-scraped and pre-flushed racked ware.

**NOTE**

If detergent is fed manually, prep full tank of fresh water with 3 oz. of a low suds detergent. On following cycles add 1 oz. of detergent.

- (6) Close door, press and hold START-FILL switch (1) in START position. Lighted switch will indicate machine is operating.
- (7) During wash cycle, WASH TEMP (5) must reach and maintain a temperature of 1500F for 93 seconds.
- (8) During rinse cycle, RINSE FLOW PRESS (4) must be 20 PSI; RINSE TEMP (3) must maintain 1000F for 24 seconds.
- (9) When wash cycle has finished start-fill indicator light turns off.
- (10) Open door and remove racked ware.

- b. Electric Griddle (FIGURE 2-204).

**WARNING**

Hot surface may cause serious burns and injury.

- (1) Seasoning the griddle

- (a) Set LEFT SIDE TEMPERATURE CONTROL (1) and RIGHT SIDE TEMPERATURE CONTROL (2) to 3000F.

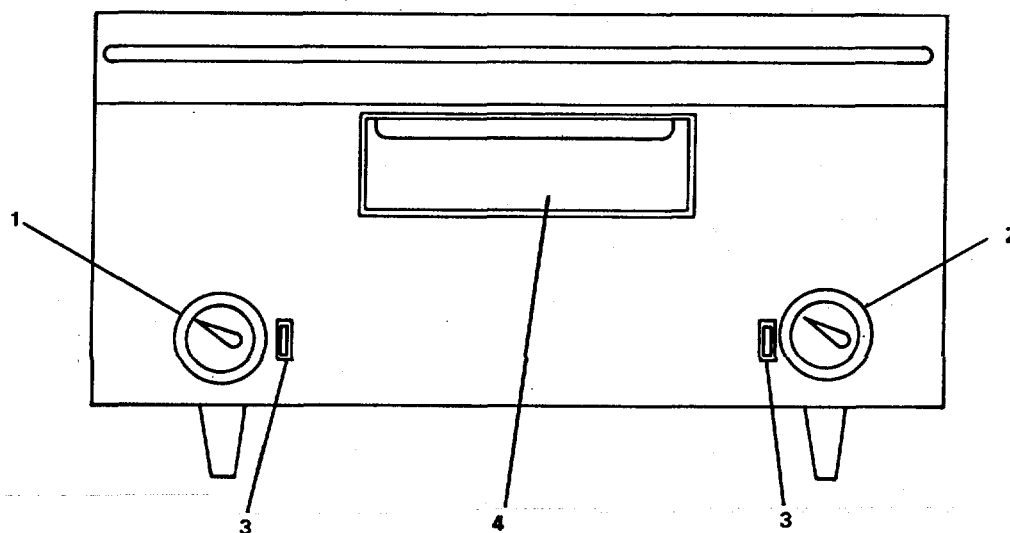

**LEGEND**

- 1. LEFT SIDE TEMPERATURE CONTROL**  
**2. RIGHT SIDE TEMPERATURE CONTROL**  
**3. HEATING INDICATOR LIGHT**  
**4. GREASE DRAWER**

FIGURE 2-204. Electric Griddle.

- (b) When HEATING INDICATOR LIGHTS (3) go out, use a clean soft cloth to spread light film of unsalted cooking oil or fat over cooking surface.
- (c) Wait 2 minutes and wipe excess oil off cooking surface with clean soft cloth.
- (d) Set LEFT SIDE TEMPERATURE CONTROL (1) and RIGHT SIDE TEMPERATURE CONTROL (2) to 3500F and repeat steps (a) through (c) above.

(2) Operation

- (a) Set LEFT SIDE TEMPERATURE CONTROL (1) and RIGHT SIDE TEMPERATURE CONTROL (2) to desired temperature. When HEATING INDICATOR LIGHTS (3) go out griddle is ready.
- (b) Use spatula to turn food being cooked and use it to push excess oil or grease into the grease trough and into grease drawer. This will reduce smoking.
- (c) Set LEFT SIDE TEMPERATURE CONTROL (1) and RIGHT SIDE TEMPERATURE CONTROL (2) to 2000F during idle periods.

(3) Shutdown

- (a) Set LEFT SIDE TEMPERATURE CONTROL (1) and RIGHT SIDE TEMPERATURE CONTROL (2) to OFF position.
- (b) Heating Indicator Lights (3) should go OFF.
- (c) Empty GREASE DRAWER (4) into an approved container after each shift and wash it with washing detergent.

c. Gaylord Control Cabinet (FIGURE 2-205).

**CAUTION**

- Cooking equipment must be shut off before pressing the stop pushbutton. Failure to do this will cause excessive heat buildup.
- The only approved detergent for use with the Gaylord System is FORMULA G-510. Use of any other detergent may void warranty.

(1) Operation.

**NOTE**

Ensure all valves and circuit breakers are set as required.

- (a) Open suction valve and discharge valves at pump (located in Foul Weather Gear Locker).
- (b) On Power Panel P106 set GAYLORD HOOD circuit breaker 8 to ON position.
- (c) On Power Panel P202 set GAYLORD HOOD WTR WASHDOWN BSTR HTR circuit breaker 6 to ON position.

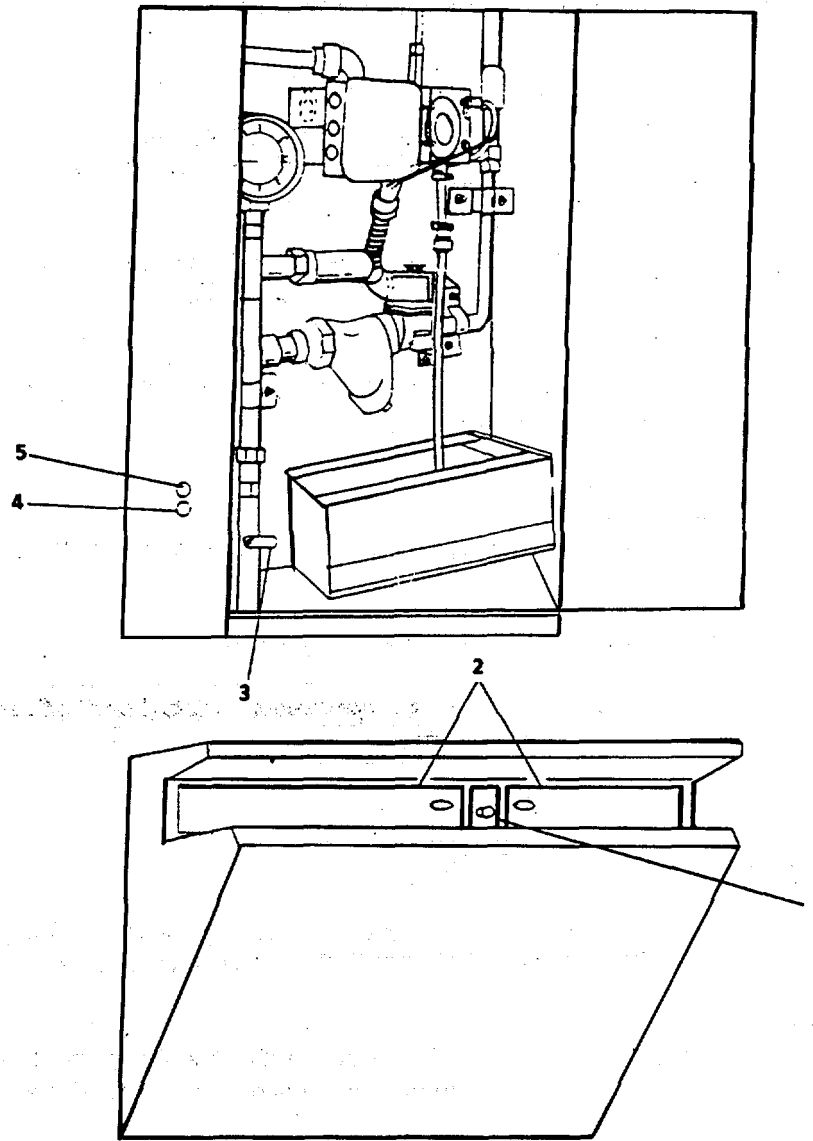

**LEGEND**

- 1. BAFFLE HANDLE
- 2. INSPECTION DOORS
- 3. HOT WATER VALVE
- 4. START
- 5. STOP

FIGURE 2-205. Gaylord Hood Controls.

- (d) On Power Panel P204 set HOT WATER BOOSTER PUMP circuit breaker 4 to ON position.
- (e) Ensure HOT WATER VALVE (3) is open.
- (f) Ensure BAFFLE HANDLE (1) is open (pushed in).
- (g) On Power Panel P211 set GALLEY EXH circuit breaker 7 and GALLEY MAKE-UP SUPPLY circuit breaker 9 to ON positions.
- (h) In Galley, on Motor Controller P211-7 set ON-OFF control switch (1, FIGURE 2-206) to ON position.
- (i) In galley, on Motor Controller P211-9, set ON-OFF switch (1) to ON position.
- (j) Press START pushbutton (2), on P211-7 and P211-9 Motor Controllers.

(2) Shutdown

- (a) Press STOP pushbutton (5, FIGURE 2-205).
- (b) This will start the automatic wash cycle.

**WARNING**

Wait until wash cycle is complete before opening inspection doors.

- (c) Open inspection doors (2). If baffles are not clean, close inspection doors (2) and press START pushbutton (4). After completion of wash cycle reinspect.
  - (d) Start fans by pressing START pushbutton (2, FIGURE 2-206) on MOTOR CONTROLLERS.
  - (e) Press STOP pushbutton (5, FIGURE 2-205) to start another wash cycle.
- d. Electric Range (FIGURE 2-207).

(1) Range top operation

- (a) Set desired LEFT-CENTER-RIGHT control (1) to 800°F and preheat for 10 minutes.
- (b) Appropriate indicator (4) will light.
- (c) Set selected control to desired heat setting, place pot or vessel on range and cook.

(2) Range top shutdown

- (a) Shut down range by setting selected LEFT-CENTER-RIGHT control (1) to OFF position.

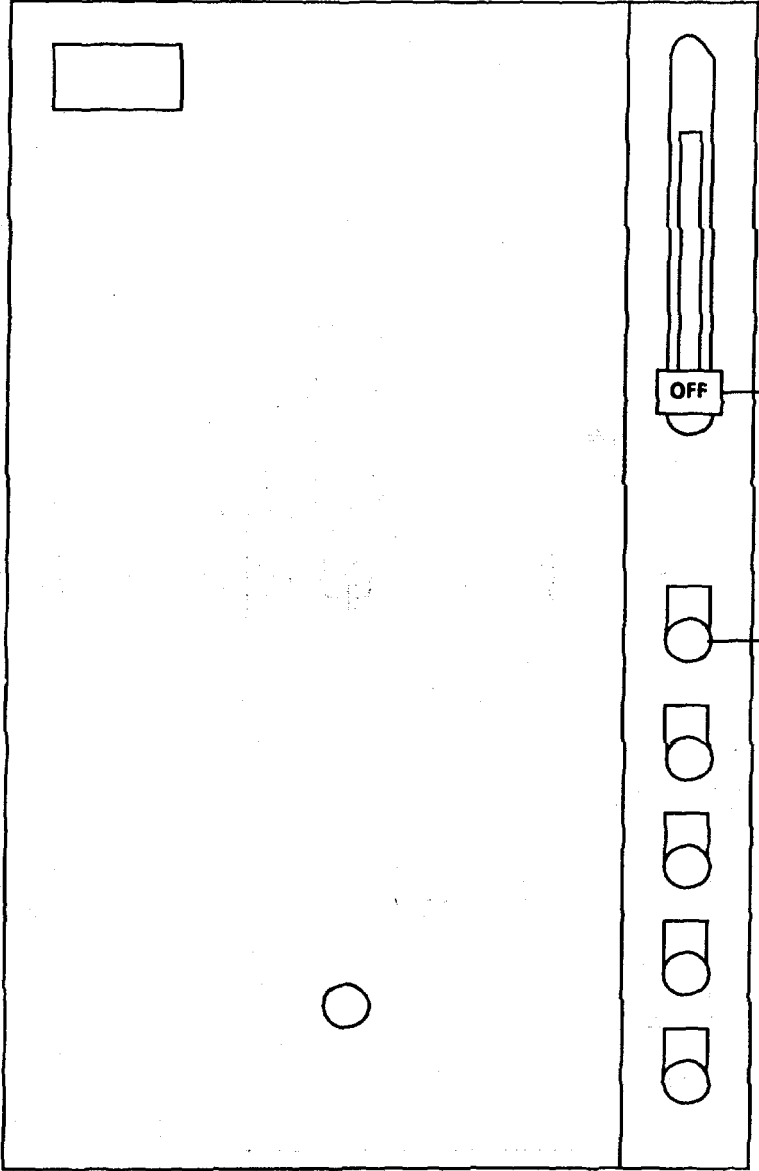

- LEGEND**  
1. **CIRCUIT BREAKER HANDLE**  
2. **START PUSHBUTTON**

FIGURE 2-206. Motor Controller.

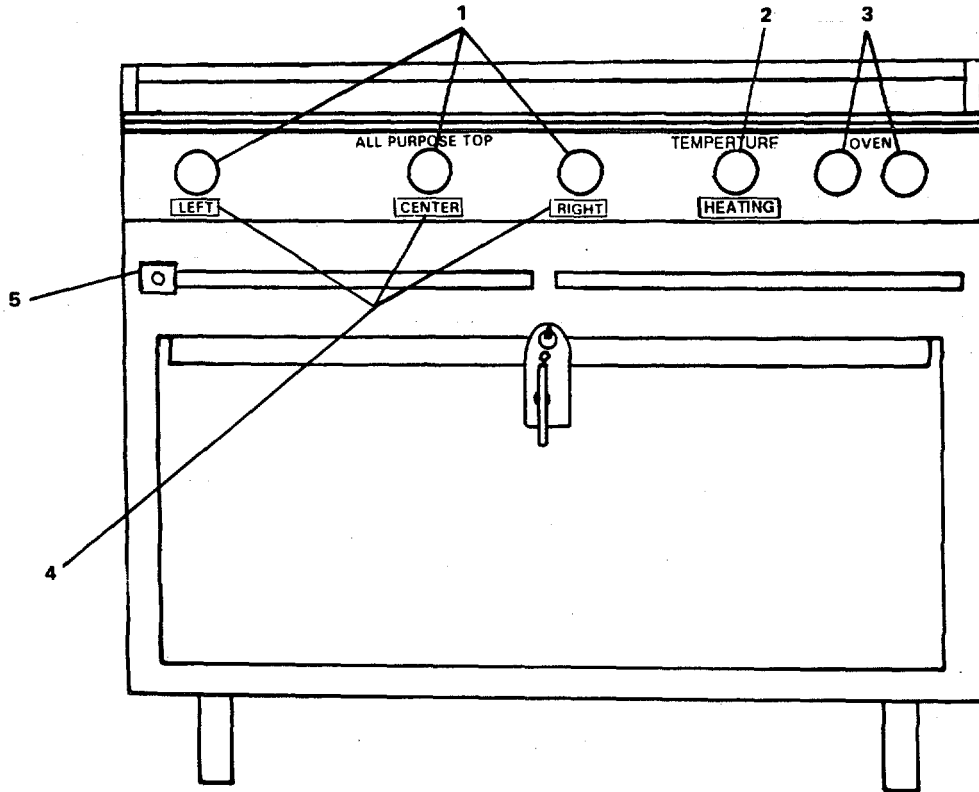

**LEGEND**

- |                             |                               |
|-----------------------------|-------------------------------|
| 1. CONTROL DIAL             | 4. LEFT CENTER RIGHT (LIGHTS) |
| 2. OVEN TEMPERATURE CONTROL | 5. OPEN-PULL CONTROL          |
| 3. OVEN                     |                               |

FIGURE 2-207. Marine Electric Range.

- (b) Appropriate indicator (4) goes out.
- (3) Oven operation.
  - (a) Set oven TEMPERATURE-HEATING control (2) to desired temperature.
  - (b) Set OVEN power switch (3) to ON position.
  - (c) Open oven vent by pulling out OPEN-PULL control (5).
  - (d) Allow oven to preheat to desired temperature setting. When oven reaches temperature setting, the signal light will go out.
  - (e) Place pans containing food in oven.
  - (f) When cooking is complete, remove food pans.
- (4) Oven shutdown. Shut down oven by setting oven TEMPERATURE-HEATING control (2) to OFF and OVEN power switch (3) to OFF position.
- e. Electric Mixer (FIGURE 2-208).
  - (1) Operation.
    - (a) Select desired attachment, line up slots in ATTACHMENT SPINDLE (8, FIGURE 2-208) with the pins on the BEATER SHAFT (9).

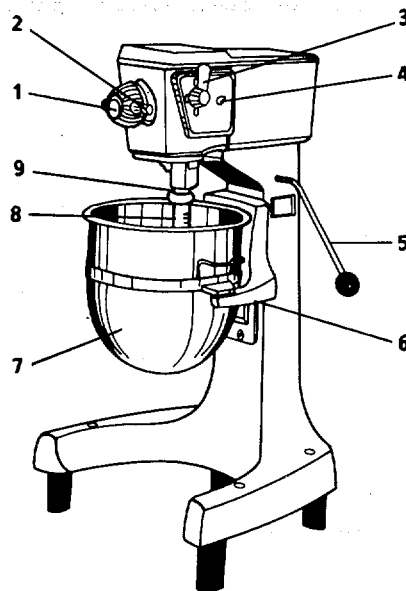

**LEGEND**

- |                           |                       |
|---------------------------|-----------------------|
| 1. AUXILIARY DRIVE SOCKET | 6. BOWL SUPPORT       |
| 2. THUMB SCREW            | 7. BOWL               |
| 3. SPEED CHANGE LEVER     | 8. ATTACHMENT SPINDLE |
| 4. ON-OFF POWER SWITCH    | 9. BEATER SHAFT       |
| 5. BOWL LIFT HAND LEVER   |                       |

FIGURE 2-208. Electric Mixer.



- (b) Raise the attachment on the BEATER SHAFT (9) and twist right. When released, attachment will drop slightly into full locked position.
  - (c) Place BOWL (7) on BOWL SUPPORT (6).
  - (d) Place ingredients in BOWL (7).
  - (e) Raise BOWL LIFT HAND LEVER (5) to the up position.
  - (f) Select desired speed on SPEED CHANGE LEVER (3).
  - (g) Set ON-OFF power switch (4) to ON position.
  - (h) When mixing is complete, set ON-OFF power switch (4) to OFF position.
  - (i) Lower BOWL LIFT HAND LEVER (5) to the down position.
  - (j) Remove BOWL (7) from BOWL SUPPORT (6).
  - (k) Remove attachment on BEATER SHAFT (9) by holding near top, raise slightly while twisting left and slide downward.
- (2) Mounting of Accessories.
- (a) Remove cover plate from AUXILIARY DRIVE SOCKET (1).
  - (b) Turn THUMB SCREW (2) counterclockwise so that it does not extend into drive socket.
  - (c) Insert hub of attachment into AUXILIARY DRIVE SOCKET (1), rotating slightly until it slides into place against mixer housing.
  - (d) Turn THUMB SCREW (2) clockwise to lock attachment in place.
- f. Meat Slicer (FIGURE 2-209).

**WARNING**

Rotating knife blade is extremely sharp and may cause serious personal injury. Keep fingers and hands clear of rotating knife blade when in use. Use caution when cleaning knife blade.

- (1) Operation.
- (a) To slice large item of regular shape (bacon or cold boiled ham), place item on CARRIAGE (2) place MEAT GRIP (1) against meat and pull CARRIAGE (2) to rear.
- (b) Adjust SLICE ADJUSTING DIAL (3) for desired thickness.
- (c) Place tray on TRAY SHELF (5) to receive slices.
- (d) Set ON-OFF switch (4) to ON position.

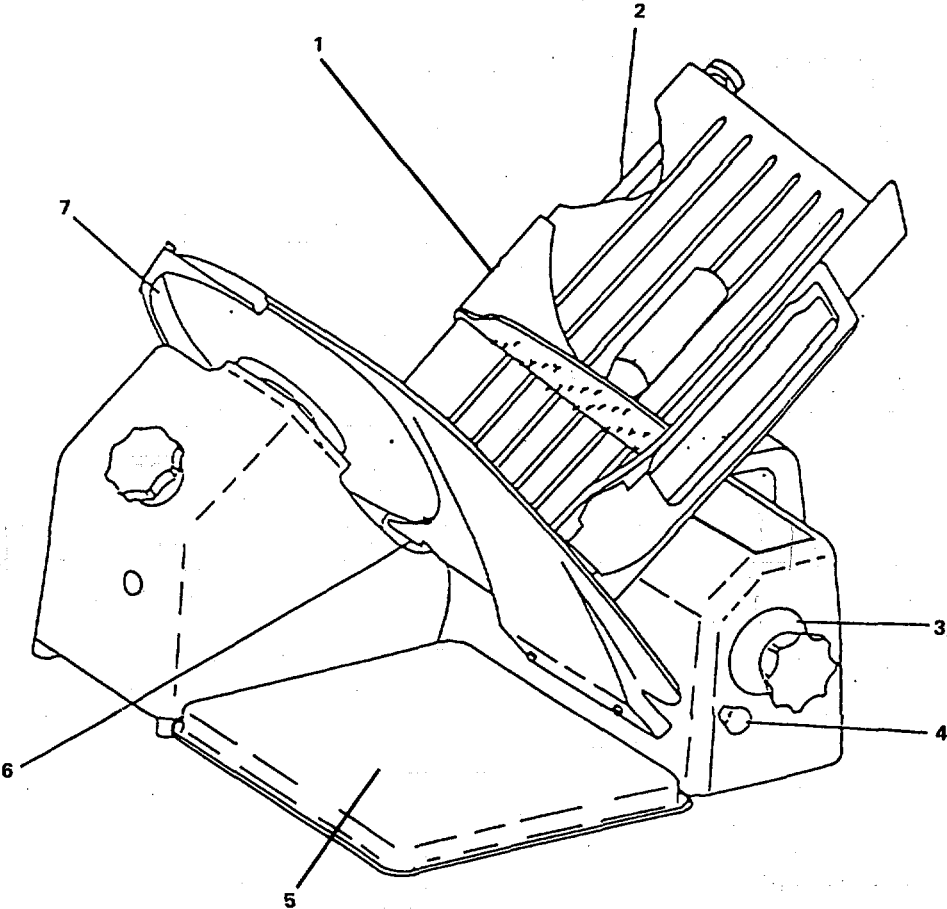

**LEGEND**

- 1. MEAT GRIP
- 2. CARRIAGE
- 3. SLICE ADJUSTING DIAL
- 4. ON-OFF SWITCH
- 5. TRAY SHELF
- 6. GAUGE PLATE
- 7. SLICER KNIFE

FIGURE 2-209. Meat Slicer.

- (e) Move CARRIAGE (2) back and forth with the right hand.
- (2) Shutdown. Set ON-OFF switch (4) in the OFF position; adjust SLICE ADJUSTING DIAL (3) to its minimum setting. This will set the GAUGE PLATE (6) to cover the SLICER KNIFE (7).
- g. Microwave Oven (FIGURE 2-210).

**WARNING**

- To prevent personal injury, do not operate microwave oven when door gasket or door seal is damaged.
  - Do not put metal in oven.
  - Do not operate oven when it is empty.
  - Do not pour water into bottom of oven.
  - Do not place heat sealed containers in oven.
- (1) Open door; place food in oven and close door.
  - (2) Press time pad numbers (1) to set time; digital timer display (8) indicates time; press either DEF pad (4) or MED pad (3); press START pad (2). PWR (7) indicator lights; DEF (4) or MED (3) indicator lights; and DIGITAL TIMER (8) display counts down time.
  - (3) When time expires, oven will turn off automatically and tone will sound to signal end of operation.
  - (4) Open door and remove food.
  - (5) Close door.

h. Milk Dispenser (FIGURE 2-211).

- (1) Preparation for use.
  - (a) Use key to unlock door.
  - (b) Open door by disengaging latch (2) and pulling on door edge.
  - (c) Place MILK CONTAINER (1) over DISPENSING VALVE (3).
  - (d) Open DISPENSING VALVE (3) and feed tube from MILK CONTAINER (1) through tube passage.

**CAUTION**

Do not stretch tube. Pulling on tube may cause the tube to pull loose from MILK CONTAINER (1), causing MILK CONTAINER (1) to drain.

- (e) Remove polyethylene film covering tube.

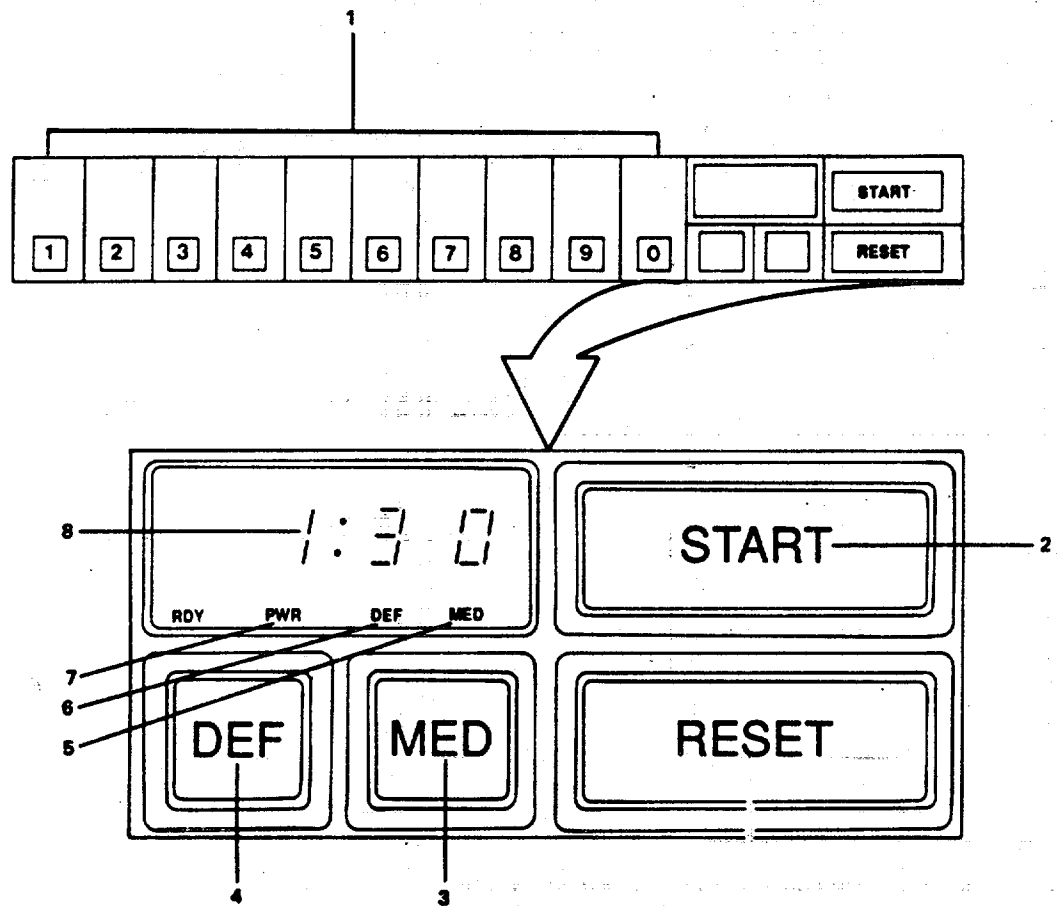

**LEGEND**

- 1. TIME PADS
- 2. START PAD
- 3. MEDIUM POWER PAD
- 4. DEFROST PAD

- 5. MEDIUM POWER INDICATOR LIGHT
- 6. DEFROST INDICATOR LIGHT
- 7. POWER INDICATOR LIGHT
- 8. DIGITAL TIMER DISPLAY

FIGURE 2-210. Microwave Oven Panel.

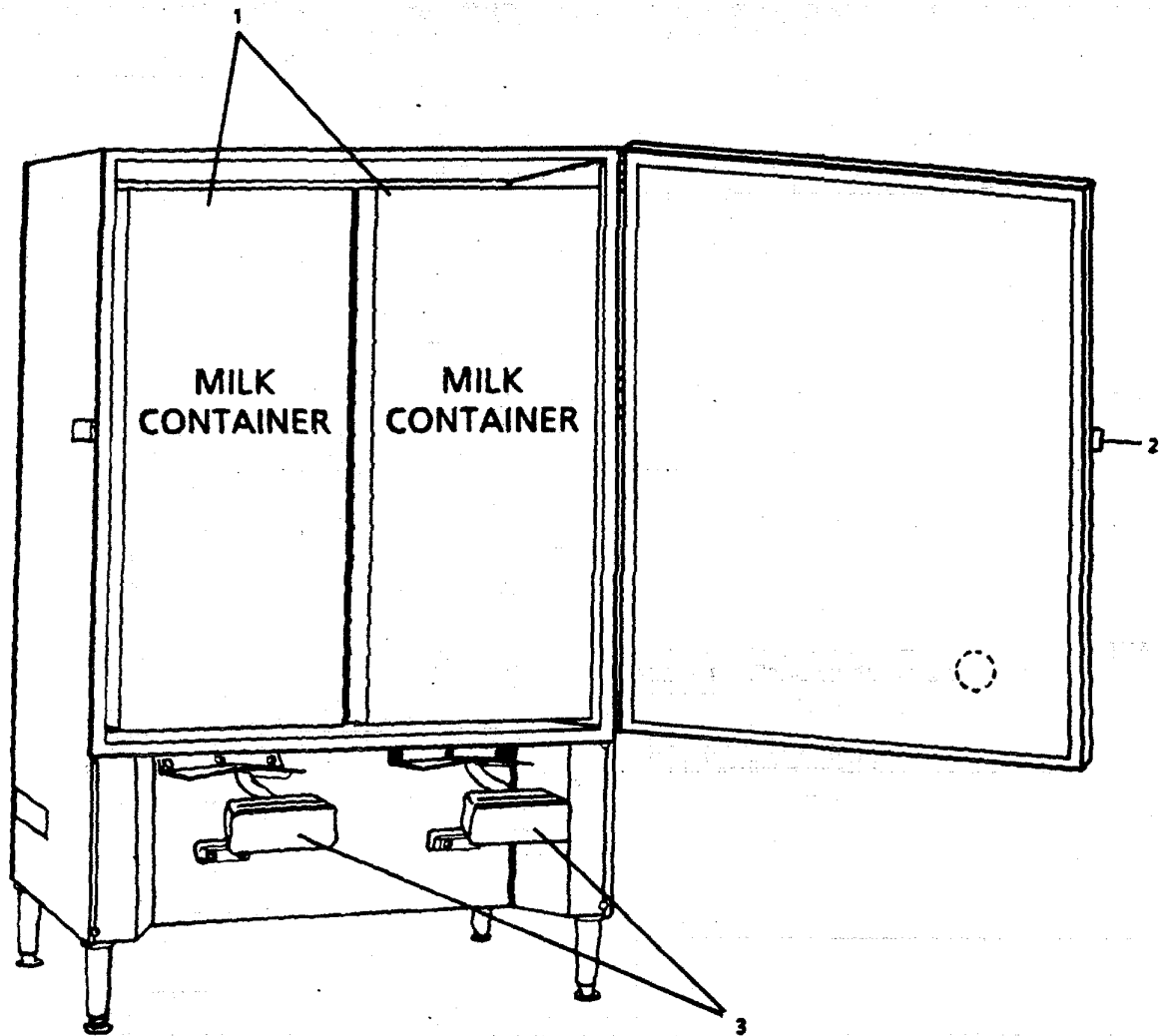

**LEGEND**

- 1. MILK CONTAINER
- 2. LATCH
- 3. DISPENSING VALVE

FIGURE 2-211. Milk Dispenser.

- (f) Close DISPENSING VALVE (3).
- (g) Remove plug from feed tube.

**NOTE**

If feed tube is too long, cut off 1/2 inch below valve.

- (h) Close door, and secure latch (2).
- (i) Lock door with key; remove key.
- (2) Operation.
- (a) Hold container under feed tube of selected DISPENSING VALVE (3).
- (b) Raise DISPENSING VALVE (3), milk will flow into container.
- (c) When container is filled to desired level, lower DISPENSING VALVE (3).
- i. Post-Mix Dispenser (FIGURE 2-212).
- (1) Hold container under desired DRINK SPOUT (2).
- (2) Press container against DISPENSING LEVER (1).
- (3) When container is filled to desired level, release container from against DISPENSING LEVER (1).
- j. Trash Compactor (FIGURE 2-213).

**WARNING**

- Do not compact any container or aerosol cans which might contain poisonous or explosive products.
- Do not compact clothing or cans containing paint liquids or thinners which could create a fire hazard.

- (1) Operation.
- (a) Open drawer by lifting DRAWER HANDLE (4), or press TOUCH-TOE BAR (3).
- (b) Place trash compactor bag in drawer and fold top over side of drawer into bag retainers.
- (c) Load trash into trash compactor bag.

**CAUTION**

Load bottles or cans on their sides in the center of the drawer. Wrap or cover wet or messy trash.

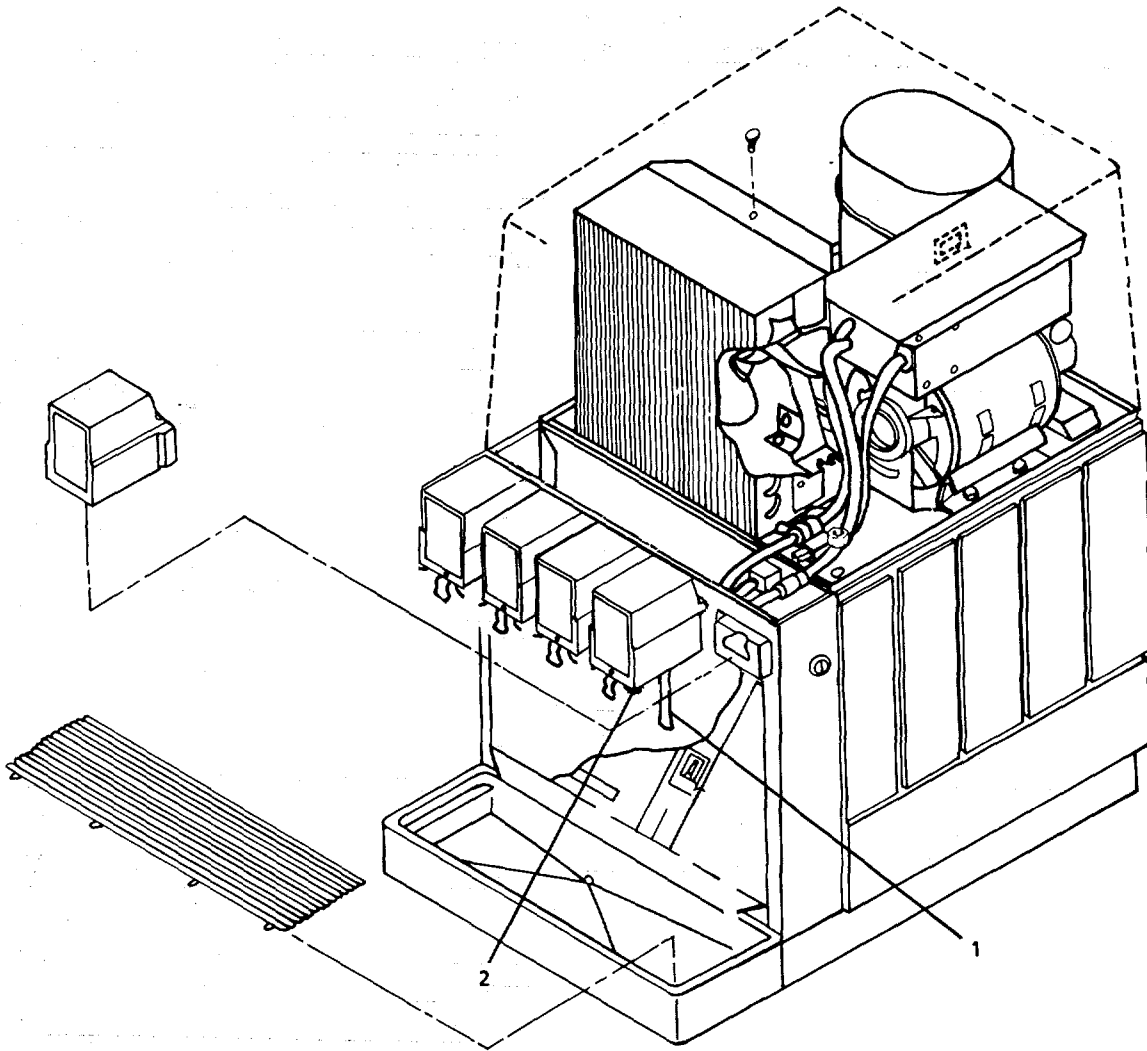

**LEGEND**

- 1. DISPENSING LEVER
- 2. DRINK SPOUT

FIGURE 2-212. Post-Mix Dispenser.

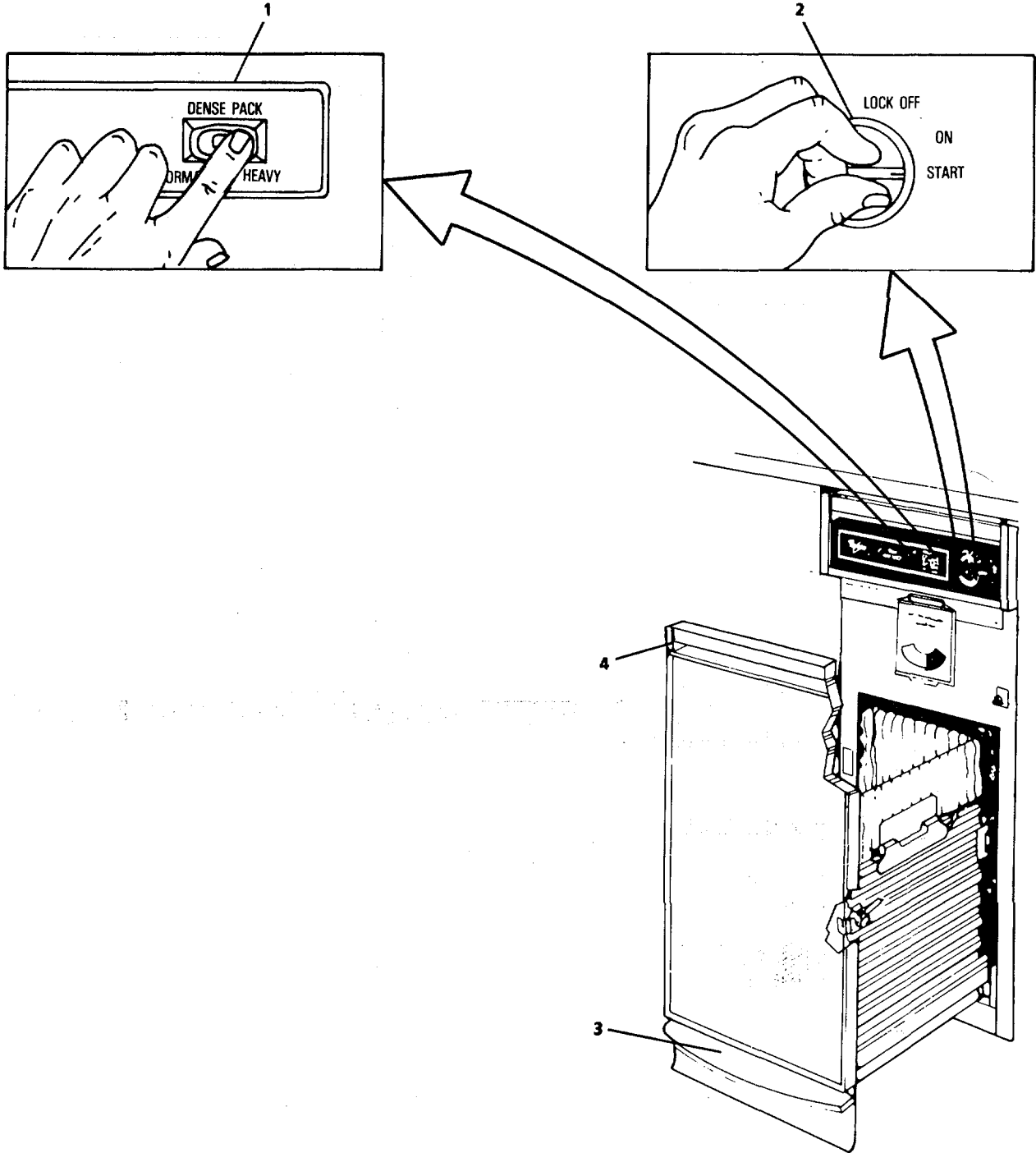

- LEGEND**
- 1. DENSE PACK SWITCH
  - 2. LOCK/OFF-ON-START SWITCH

- 3. TOUCH-TOE BAR
- 4. DRAWER HANDLE

FIGURE 2-213. Trash Compactor.



- (d) Close drawer, set DENSE PACK switch (1) to OFF position.
- (e) Turn LOCK OFF-ON-START switch (2) to START position and release.
- (f) The compactor will compress trash and stop at end of cycle.

**NOTE**

Dense pack cycle puts constant pressure on trash and keeps pressure on trash until cycle is completed.

- (2) Dense pack operation.
- (a) Set DENSE PACK switch (1) to ON position.
- (b) Turn LOCK OFF-ON-START switch (2) to START position and release.

**NOTE**

The ram will stay in the down position for extra compacting. Drawer cannot be opened when ram is down. For best results, use dense pack setting for at least one half hour each time the cycle is used.

- (c) Turn LOCK OFF-ON-START switch (2) to LOCK OFF position to raise ram, or set DENSE PACK switch (1) to OFF position.

**WARNING**

Fully compacted trash bags will be heavier than normal. Handle with care to prevent personal injury.

k. Marine Coffee Pot (FIGURE 2-214).

- (1) Ensure reservoir is filled with cold water.
- (2) Remove FUNNEL (2) from hood guides.
- (3) Place filter in FUNNEL (2) and add desired amount of coffee.
- (4) Level coffee and insert FUNNEL (2) in hood guides.
- (5) Place empty COFFEE POT (3) on center warmer under FUNNEL (2).
- (6) Set START switch (4) to ON position, coffee will brew.
- (7) Set HOT PLATE ON-OFF switch (1) to ON.
- (8) Set START switch (4) to OFF position when coffee brewing is completed.

1. Fry Kettle (FIGURE 2-215).

**WARNING**

Overfilling Fryer OIL CONTAINER with cooking oil may result in oil spilling into deck causing slippery conditions. Overfilling may also present a fire hazard.

- (1) Fill Fryer OIL CONTAINER (4) with cooking oil to above top of HEATING ELEMENT (3).

**WARNING**

Failure to keep oil level above top of heating element will result in overheat of element sheaths, and a possible flash fire if oil is splashed on them.

- (2) Set THERMOSTAT DIAL (2) to desired temperature. Observe INDICATOR LIGHT (1) is lit.

**NOTE**

When cooking oil reaches desired temperature, INDICATOR LIGHT (1) will go out.

- (3) Place food in wire-mesh type COOKING BASKET and place basket in hot cooking oil.  
 (4) When food is cooked, remove basket and hang it on support to allow excess oil to drain off.

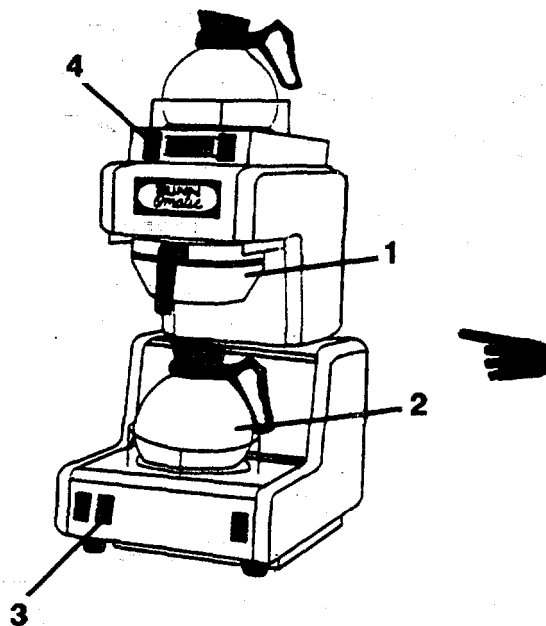

**LEGEND**

- |               |                            |
|---------------|----------------------------|
| 1. FUNNEL     | 3. HOT PLATE ON-OFF SWITCH |
| 2. COFFEE POT | 4. START SWITCH            |

FIGURE 2-214. Marine Coffee Pot.

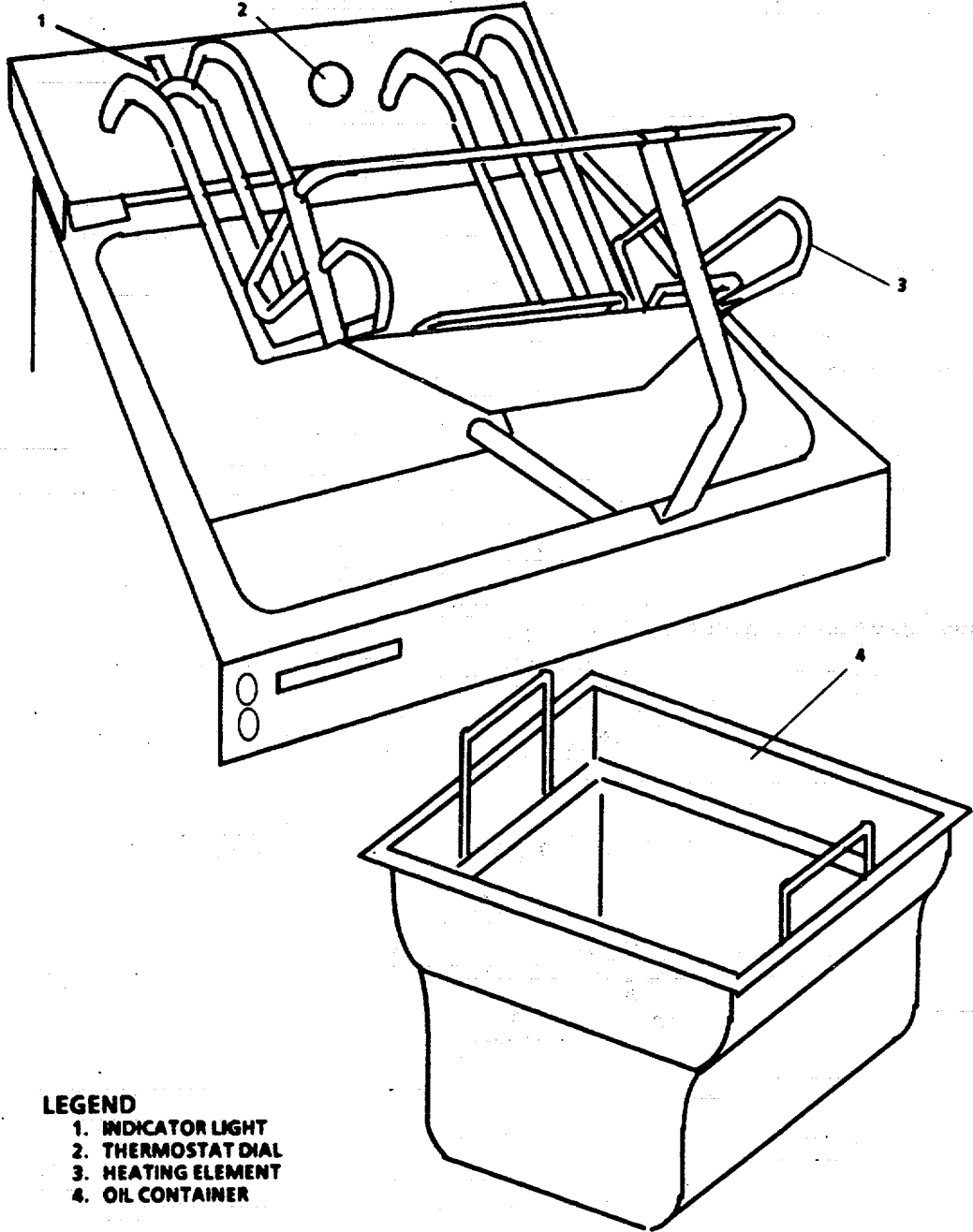

- LEGEND**
- 1. INDICATOR LIGHT
  - 2. THERMOSTAT DIAL
  - 3. HEATING ELEMENT
  - 4. OIL CONTAINER

FIGURE 2-215. Fry Kettle.

**WARNING**

- Keep oil level above top of heating element. Failure to do so will result in overheating of the element sheaths and possible flash fire if oil is splashed on them.
  - When fry kettle is in operation an attendant must always be present.
- (5) To shut down the fry kettle, set THERMOSTAT DIAL (2) to OFF position.

**WARNING**

Allow heating elements to cool down before raising HEATING ELEMENTS (3) from cooking oil. The hot elements and hot cooking oil may cause severe burns.

- (6) When cooking oil has cooled down, raise HEATING ELEMENTS (3) to the intermediate position and allow to drain a few seconds, then swing to the upright position.

**NOTE**

Remove OIL CONTAINER (4) from fry kettle and pour oil contents into reusable container for later disposal.

- m. Refrigerator model R18-2M-S (FIGURE 2-216). At Galley Power Panel P106 set 20 CU FT REFRIGERATOR circuit breaker 4 to ON position. This unit is factory set to maintain temperature of 350F. No other operating instructions are required.
- n. Refrigerator model R30-2M-2 (FIGURE 2-217). At Galley Power Panel P106 set 30 CU FT REFRIGERATOR circuit breaker 1 to ON position. This unit is factory set to maintain temperature of 350F. No other operating instructions are required.
- o. Freezer model F20-2M-ADS (FIGURE 2-218). At Galley Power Panel P106 set 20 CU FT FREEZER circuit breaker 5 to ON position. This unit is factory set to maintain temperature of -100F. No other operating instructions are required.
- p. Freezer model F30-2M-ADS (FIGURE 2-219). At Galley Power Panel P106 set 30 CU FT FREEZER circuit breaker 1 to ON position. This unit is factory set to maintain temperature of -10°F. No other operating instructions are required.

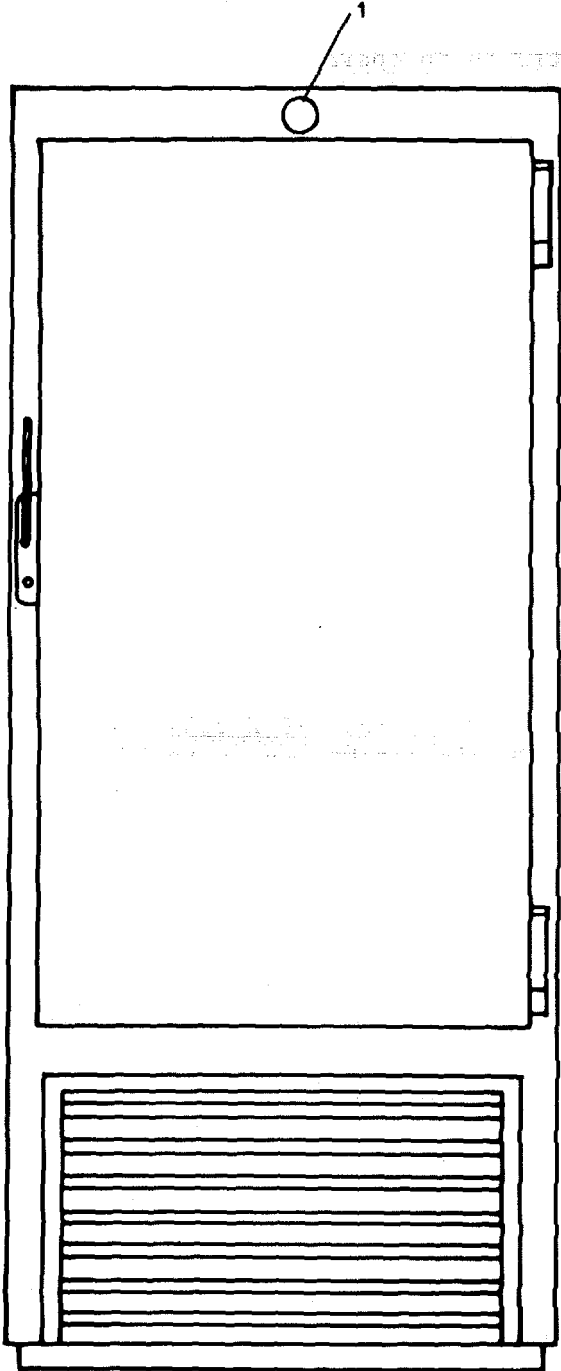

**LEGEND**  
1. THERMOMETER

FIGURE 2-216. Refrigerator Model R18-2M-S.

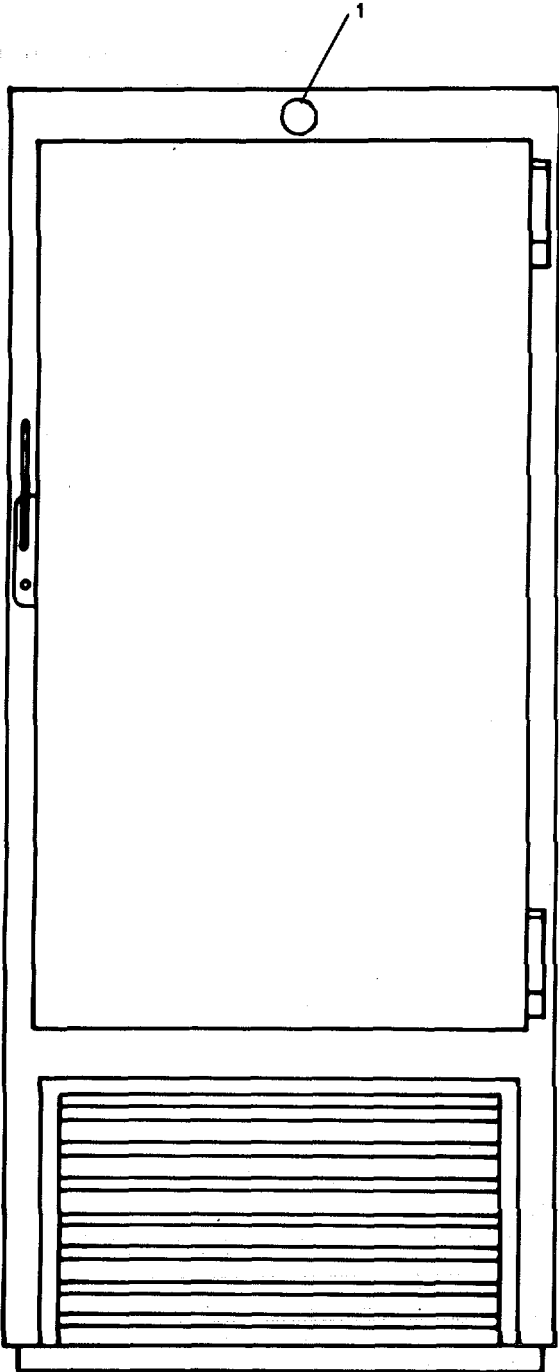

**LEGEND**

1. THERMOMETER

FIGURE 2-217. Refrigerator Model R30-2M-S.

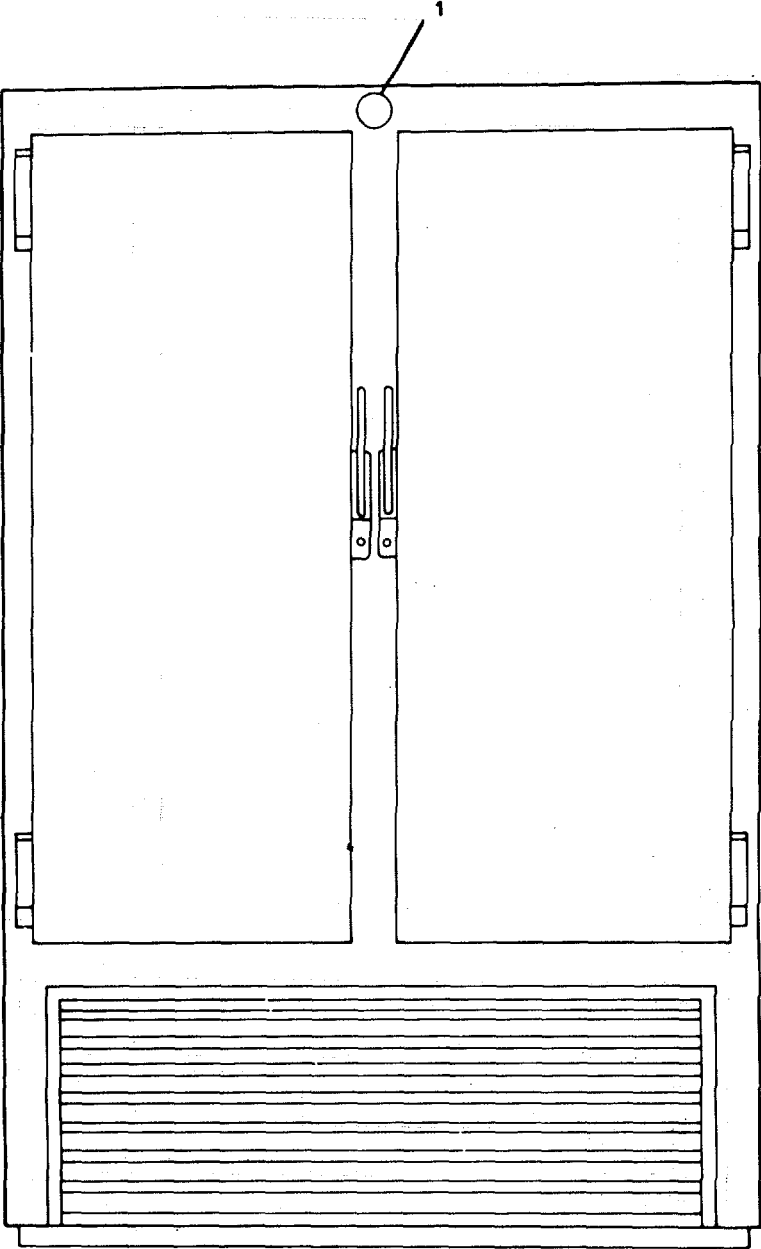

**LEGEND**  
1. THERMOMETER

FIGURE 2-218. Freezer Model F20-2M-ADS.

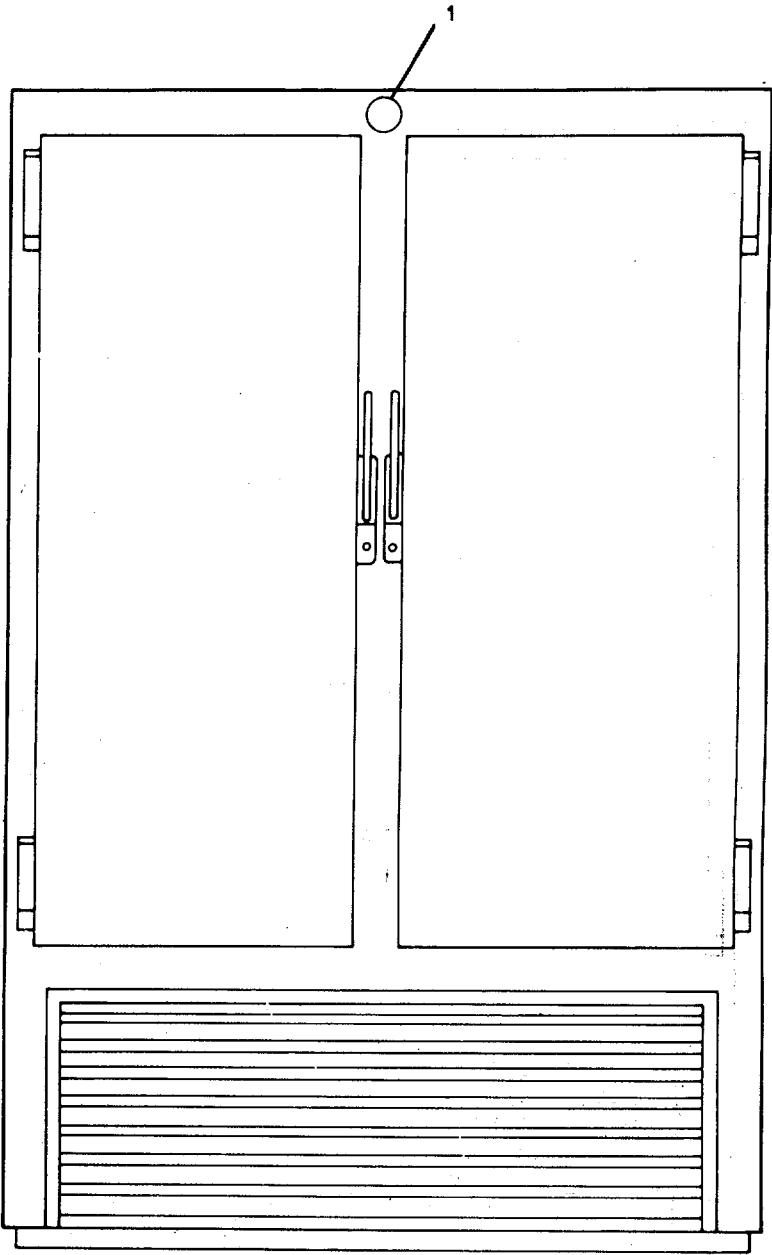

**LEGEND**

1. THERMOMETER

FIGURE 2-219. Freezer Model F30-2M-ADS.



**2-33. Liferafts and Workboat/Workboat Crane.**a. Liferaft Operation.

- (1) Tie liferaft PAINTER LINE (8, FIGURE 2-220) secure to liferaft launching ramp.
- (2) Launch liferaft as follows:
  - (a) Open PELICAN HOOK (5) by prying LOCKING RING (4) up and over end of hook.
  - (b) Release RETAINER STRAP (3).
  - (c) Two crew members lift liferaft (11) off of cradle (7) and place on launch ramp, release liferaft.
  - (d) If liferaft does not inflate after hitting water, pull sharply on PAINTER LINE (8).

**NOTE**

- Liferafts are equipped with hydrostatic releases (6) designed to release liferafts when submerged.
- Three straps (2 and 3) secured around life raft container and will release as life raft inflates.

- (e) After boarding liferaft, cut PAINTER LINE (8).

b. Startup Procedure for Rescue/Workboat Crane (FIGURE 2-221).

- (1) Turn WATERTIGHT CAP (5) counterclockwise on MOTOR CONTROLLER (7).
- (2) Insert POWER CORD (1) into socket of MOTOR CONTROLLER (7).
- (3) On MOTOR CONTROLLER (7), set OFF-ON lever to ON position.

c. Operation.**WARNING**

- Never use crane for any type of human support or transportation.
- Operator will never lift a load over other personnel. Severe injury or death could result if crane equipment fails.
- Personnel will not walk under a hoisted load. Severe injury or death could result if crane equipment fails.
- Operator will not attempt to hoist load until load and conditions allow safe operation.

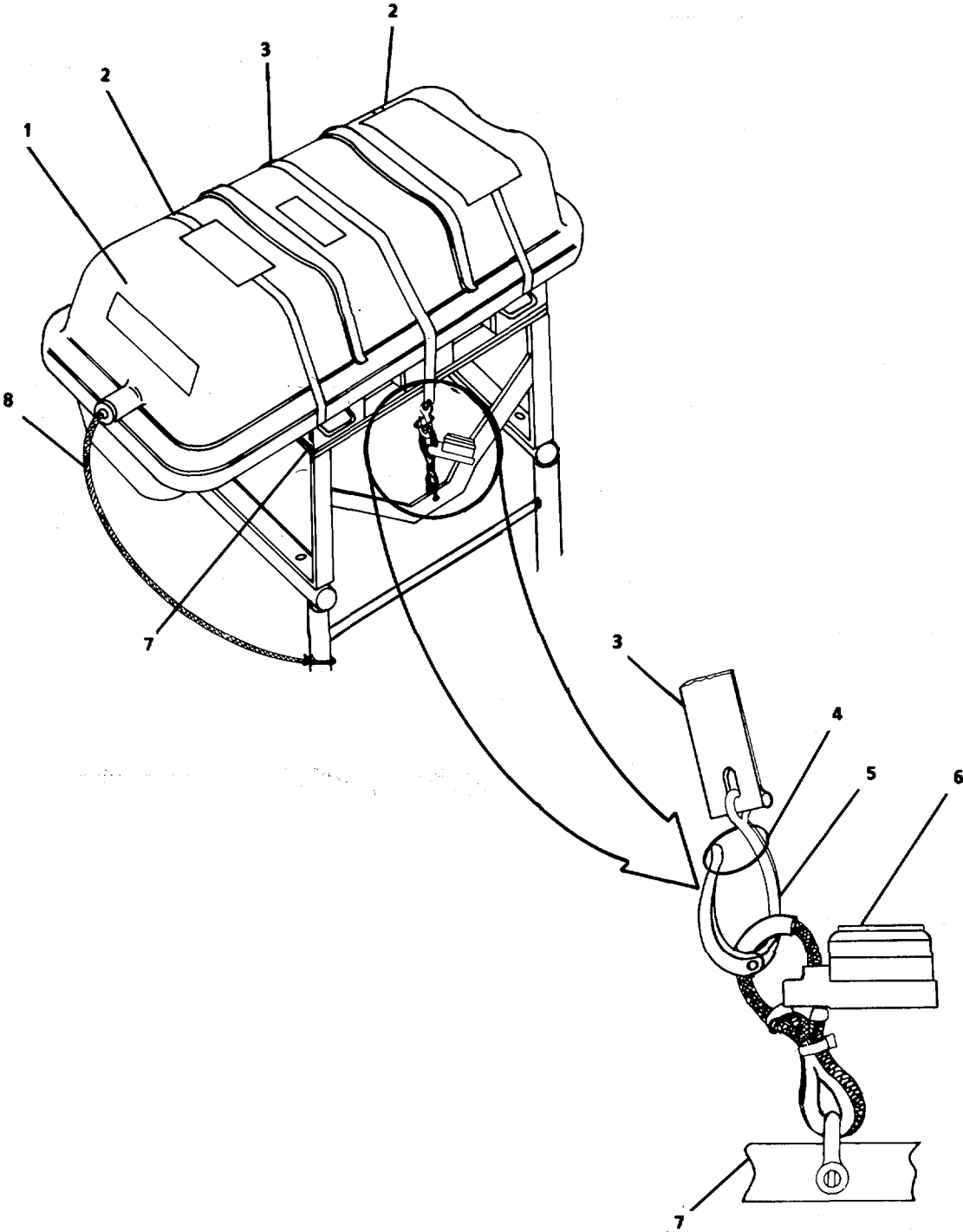

**LEGEND**

- |                           |                        |
|---------------------------|------------------------|
| 1. LIFERAFT CONTAINER     | 5. PELICAN HOOK        |
| 2. PRESSURE RELEASE STRAP | 6. HYDROSTATIC RELEASE |
| 3. RETAINER STRAP         | 7. CRADLE              |
| 4. LOCKING RING           | 8. PAINTER LINE        |

FIGURE 2-220. Life Raft Operation.

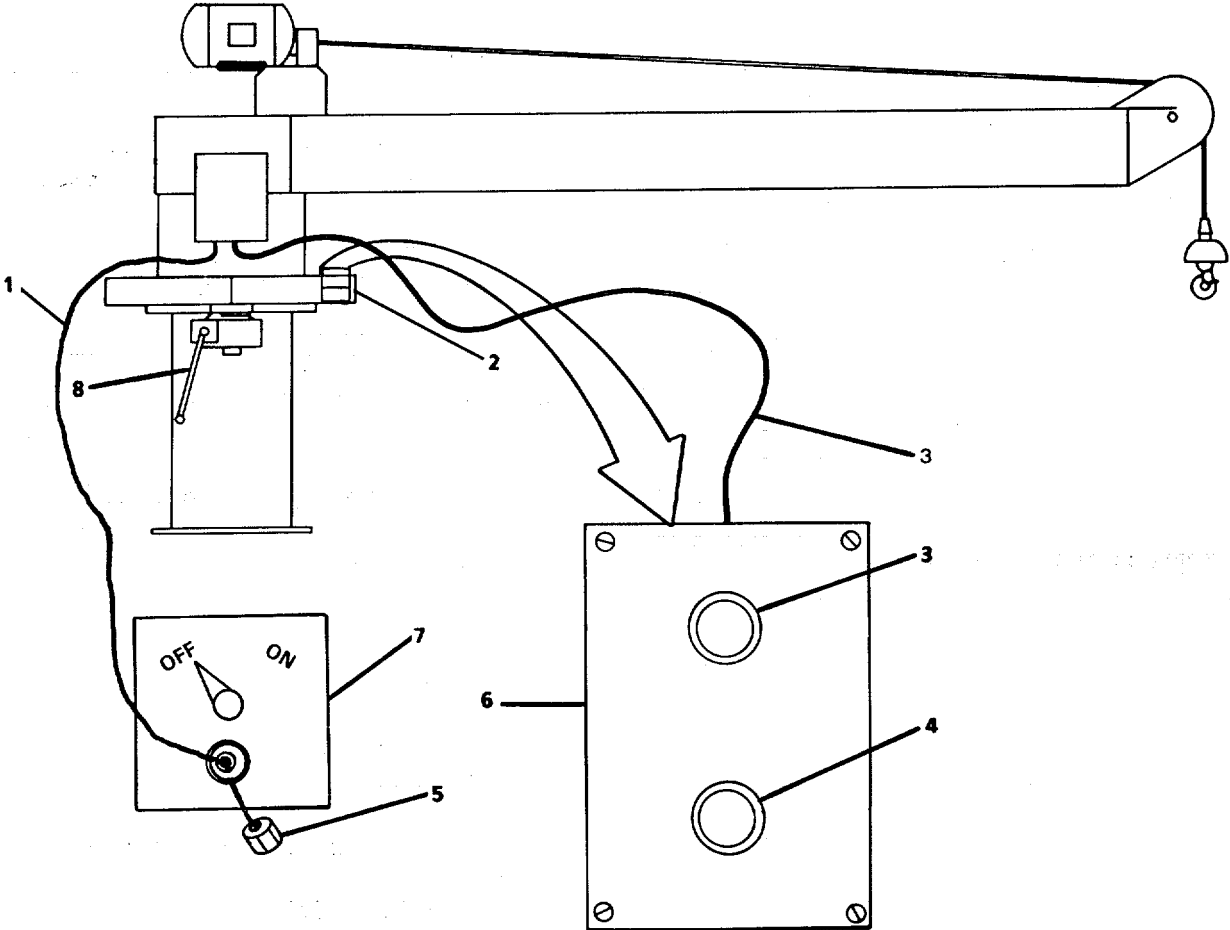

- LEGEND**
- 1. POWER CORD
  - 2. CRADLE
  - 3. UP
  - 4. DOWN

- 5. WATERTIGHT CAP
- 6. REMOTE CONTROL
- 7. MOTOR CONTROLLER
- 8. HAND CRANK

FIGURE 2-221. Rescue/Workboat Crane.

**CAUTION**

- Stop winch before load reaches crane boom.
- Ensure load comes to complete stop and is stable before changing direction of travel of crane boom.

**NOTE**

- Rescue/Work Boat Crane will be stowed attached to Rescue/Work Boat sling.
  - Three crew members will be required to launch Rescue/Work Boat.
- (1) Direct three crew member to Rescue/Work Boat station, one to operate REMOTE CONTROL (6) unit, one to operate HAND CRANK (8), and one to handle Rescue/Work boat.
  - (2) Remove tie down straps holding Rescue/Work Boat to deck cradle.
  - (3) Remove REMOTE CONTROL unit (6) from CRADLE (2).
  - (4) Press UP pushbutton (3) to raise Rescue/Work Boat from its deck cradle to clear hand rail.
  - (5) Turn HAND CRANK (8) clockwise to position boom outboard ship port side.
  - (6) Press DOWN pushbutton (4) until Rescue/Work Boat is afloat.
- d. Shutdown Procedure.

**NOTE**

Rescue/Work Boat will be stowed attached to the Rescue/Work Boat sling.

- (1) On MOTOR CONTROLLER (7, FIGURE 2-221) set OFF-ON lever to OFF position.
- (2) Remove POWER CORD (1) from socket of MOTOR CONTROLLER (7).
- (3) Turn WATERTIGHT CAP (5) clockwise on socket of MOTOR CONTROLLER (7).
- (4) Replace REMOTE CONTROL unit (6) in CRADLE (2).

**2-34. Shore Connections.**

- a. Power Cable Connection.

**WARNING**

Ensure that power cable does not enter water. Electrocutation, serious injury, or equipment damage can occur during connection if cable connector gets wet.

- (1) Pay out power cable from overhead rack up ladder to 02 stern deck.
- (2) Position cable end through bottom section of hand rail.
- (3) Tie one end of heaving line to cable end.
- (4) Throw heaving line to dockside facilities.
- (5) Remove waterproof wrapping from cable connectors.

**NOTE**

There is 75 feet of cable; direct attention to amount of cable remaining on the deck. There should be a sufficient amount of cable on deck to prevent it from paying out completely. Attach a preventer line to prevent complete cable runoff.

- (6) Coordinate cable payout between on board and dockside crew.
- (7) Connecting cables (FIGURE 2-222).

**WARNING**

Ensure electrical power is OFF at dock shore power panel prior to connecting shore power cable.

- (a) Unscrew METAL CAP (1) from base of shore power cable INPUT CONNECTOR (4).
- (b) Align key way on SHORE POWER CABLE CONNECTOR (2) with key slot in shore power cable INPUT CONNECTOR (4).
- (c) With firm upward pressure, seat SHORE CABLE CABLE CONNECTOR (2) in cable INPUT CONNECTOR (4).
- (d) Secure SHORE POWER CABLE CONNECTOR (2) by turning LOCKING RING (3) clockwise. Tighten with wrench.
- (e) At dock shore power panel, set power switch to ON position.

b. Shifting to Shore Power.

- (1) At Main Switchboard (FIGURE 2-223), ensure SHORE POWER PHASE METER (1) indicates correct phase of shore power.

**CAUTION**

If shore power phase meter indicates phase of shore power is incorrect, equipment will be damaged. Refer to unit maintenance to have shore power cable reconnected.

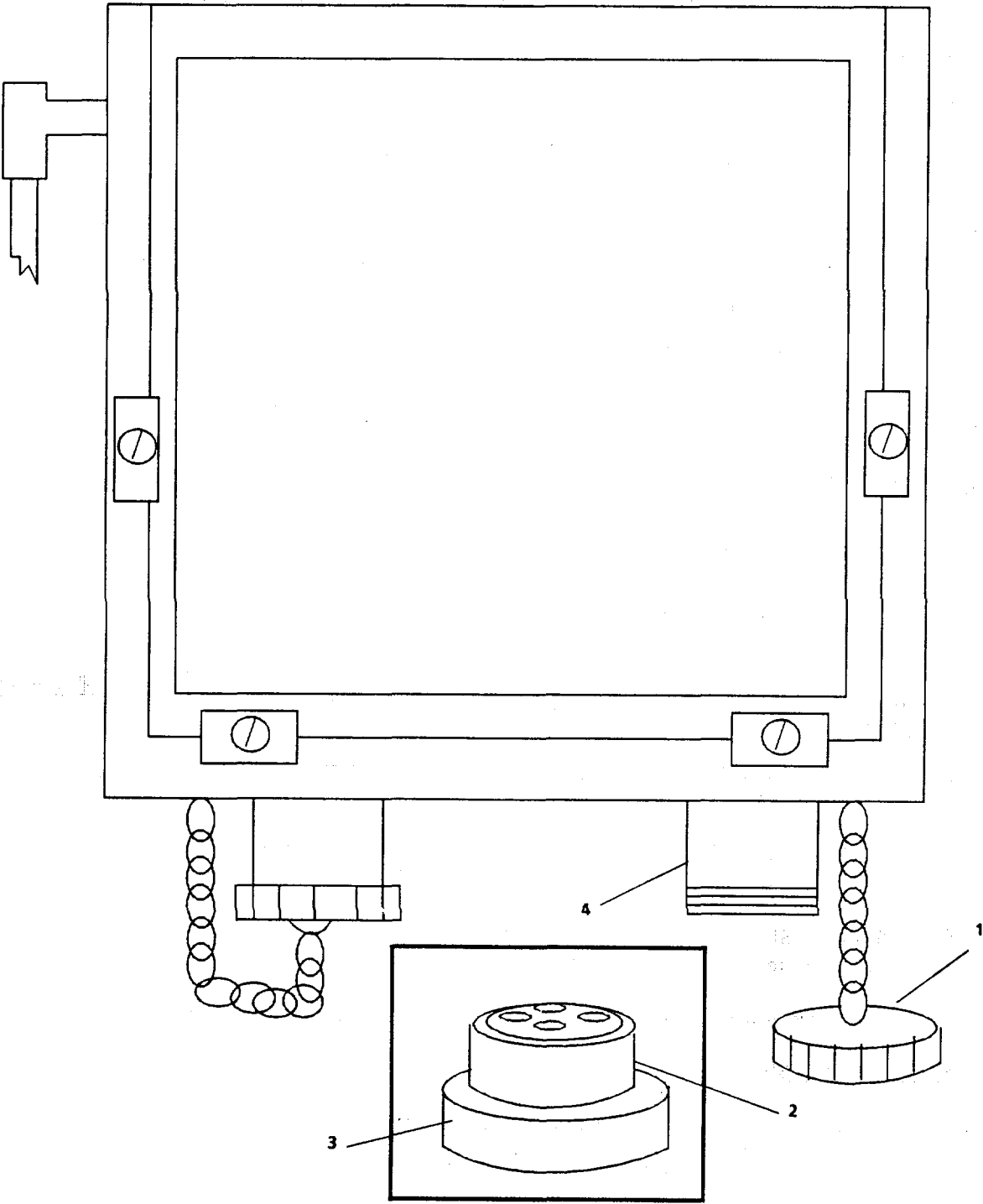

- LEGEND**
- 1. METAL CAP
  - 2. SHORE POWER CABLE CONNECTOR
  - 3. LOCKING RING
  - 4. INPUT CONNECTOR

FIGURE 2-222. On Board Shore Power Terminal Box.

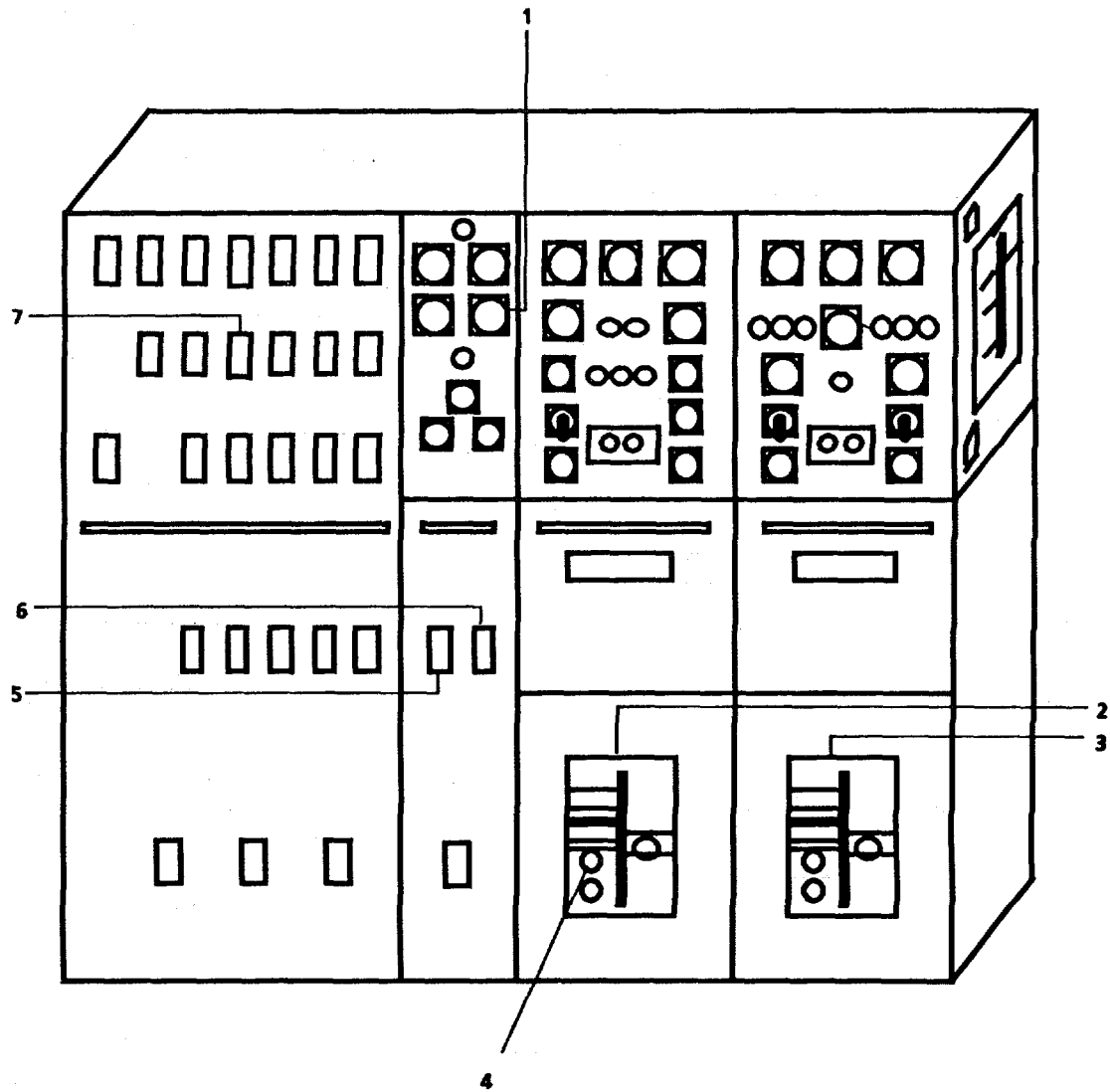

**LEGEND**

- |                                    |   |
|------------------------------------|---|
| 1. SHORE POWER PHASE METER         | 5. 480V SHORE POWER TRANSFORMER BREAKER |
| 2. GENERATOR NO. 1 CIRCUIT BREAKER | 6. 240V SHORE POWER BREAKER (BYPASS)    |
| 3. GENERATOR NO. 2 CIRCUIT BREAKER | 7. HOT WATER HEATER                     |
| 4. TRIP BUTTON                     |   |

FIGURE 2-223. Main Switchboard.

- (2) On Main Switchboard press GENERATOR 1 CIRCUIT BREAKER TRIP pushbutton (4, FIGURE 2-223).
- (3) Set shore power circuit breaker.
  - (a) If shore power is 480V, set 480V SHORE POWER TRANSFORMER BREAKER (5) to ON position.
  - (b) If shore power is 240V set 240V SHORE POWER BREAKER BYPASS (6) to ON position.

c. Power Cable Disconnect.

**WARNING**

Ensure that power cable does not enter water. Electrocutation, serious injury, or equipment damage can occur during connecting or disconnecting if cable connector gets wet.

**NOTE**

- Make an announcement over the general announcing system to place all electronic and unnecessary electrical equipment in standby while shifting from shore power to ship power.
- Ensure generators are on-line and ready to accept electrical load.

- (1) Shift from shore to ship power.
  - (a) On Main Switchboard (FIGURE 2-223), set 480V SHORE POWER TRANSFORMER BREAKER (5) to OFF position or set 240V SHORE POWER BREAKER (BYPASS) (6) to OFF position.
  - (b) On Main Switchboard (FIGURE 2-223), set GENERATOR 1 (2) and GENERATOR 2 (3) circuit breakers to ON position.

**WARNING**

Ensure electrical power switch is OFF at dock shore power panel.

- (2) Disconnect shore power cable at dock shore power panel and on-board Shore Power Terminal Box (FIGURE 2-222).

**CAUTION**

Ensure that cable does not enter water.

- (3) Coordinate cable reel-in between on-board and dockside crew. Stop-off one end of heaving line to cable end at dockside.



- (4) Stow shore power cable in overhead rack on stern main deck.
- (5) Secure cable connectors with waterproof wrapping.

d. Rigging Gangplank.

**NOTE**

- Several crew members are required to remove GANGPLANK (1, FIGURE 2-224) from its stowed position on cargo deck, port side.
- GANGPLANK GUIDE RAILS (FIGURE 2-224) are located on 01 deck, port (6) and starboard (4) sides aft, and stern end (5) (starboard).

**CAUTION**

At least one crew member will apply pressure against GANGPLANK (1) near center BRACKET (3) to prevent gangplank from tipping after BRACKETS (3) are removed.

- (1) Remove three WING-TYPE NUTS (2, FIGURE 2-224) from holding BRACKETS (3). BRACKETS (3) are hinged and swing down and away from GANGPLANK (1).
- (2) Crew members will lift GANGPLANK (1) up and away from fixed section of BRACKETS (3) and port gunnel.
- (3) Place GANGPLANK (1) down flat with WHEELS (7) on deck.
- (4) Lift CONNECTOR END (8) of GANGPLANK (1) to comfortable height and roll GANGPLANK (1) aft to location of rescue/work boat crane.

**NOTE**

Gangplank may be carried by several crew members.

- (5) Place GANGPLANK (1) down flat with WHEELS (7) on deck and CONNECTOR END (8) facing aft.
- (6) Attach appropriate type LIFTING SLING (14) to gangplank.
- (7) To operate crane (FIGURE 2-224) perform following:
  - (a) Remove WATER TIGHT CAP (17) from socket on MOTOR CONTROLLER (19).
  - (b) Insert POWER CORD (9) into socket of MOTOR CONTROLLER (19).
  - (c) On MOTOR CONTROLLER (19), set OFF-ON lever to ON position.
  - (d) Remove REMOTE CONTROL unit (18) from CRADLE (10). Press UP (12) to raise crane and press DOWN (13) to lower crane.

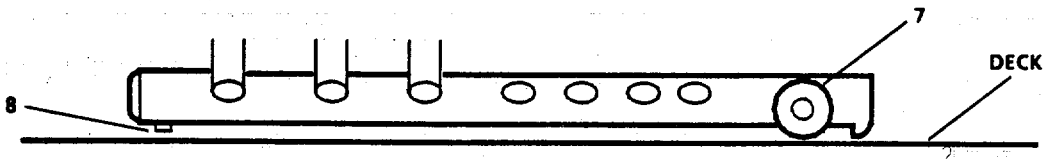
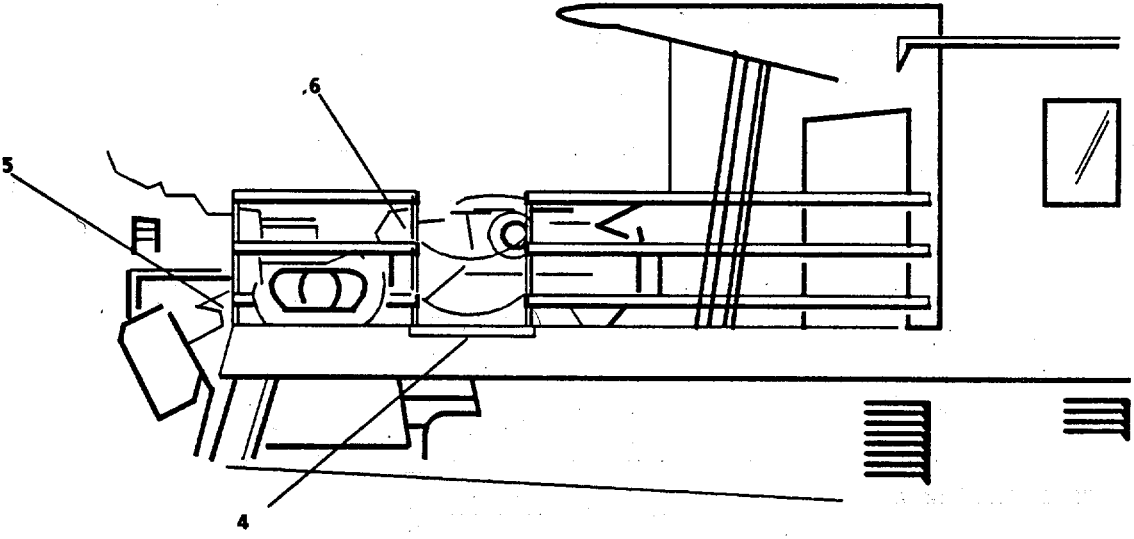
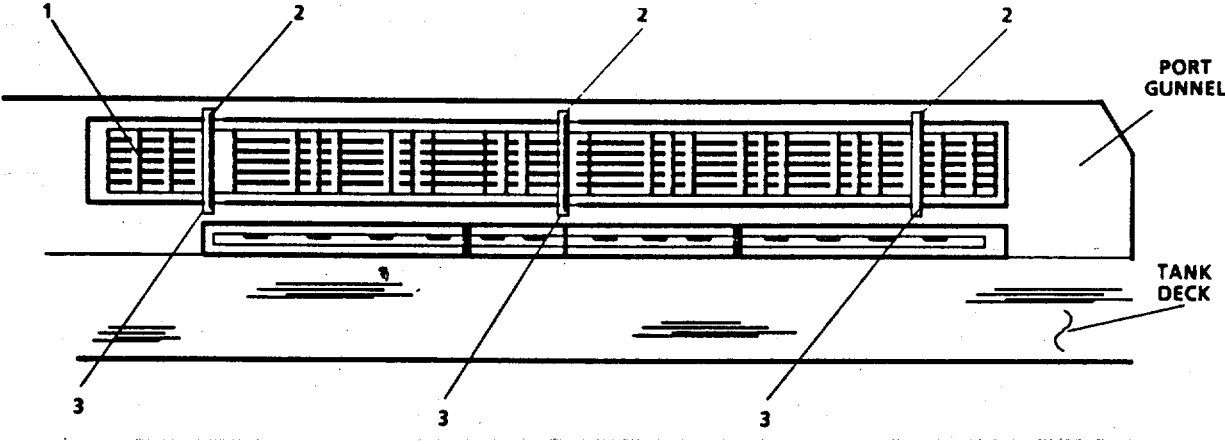

FIGURE 2-224. Rig Gangplank (Sheet 1 of 3).

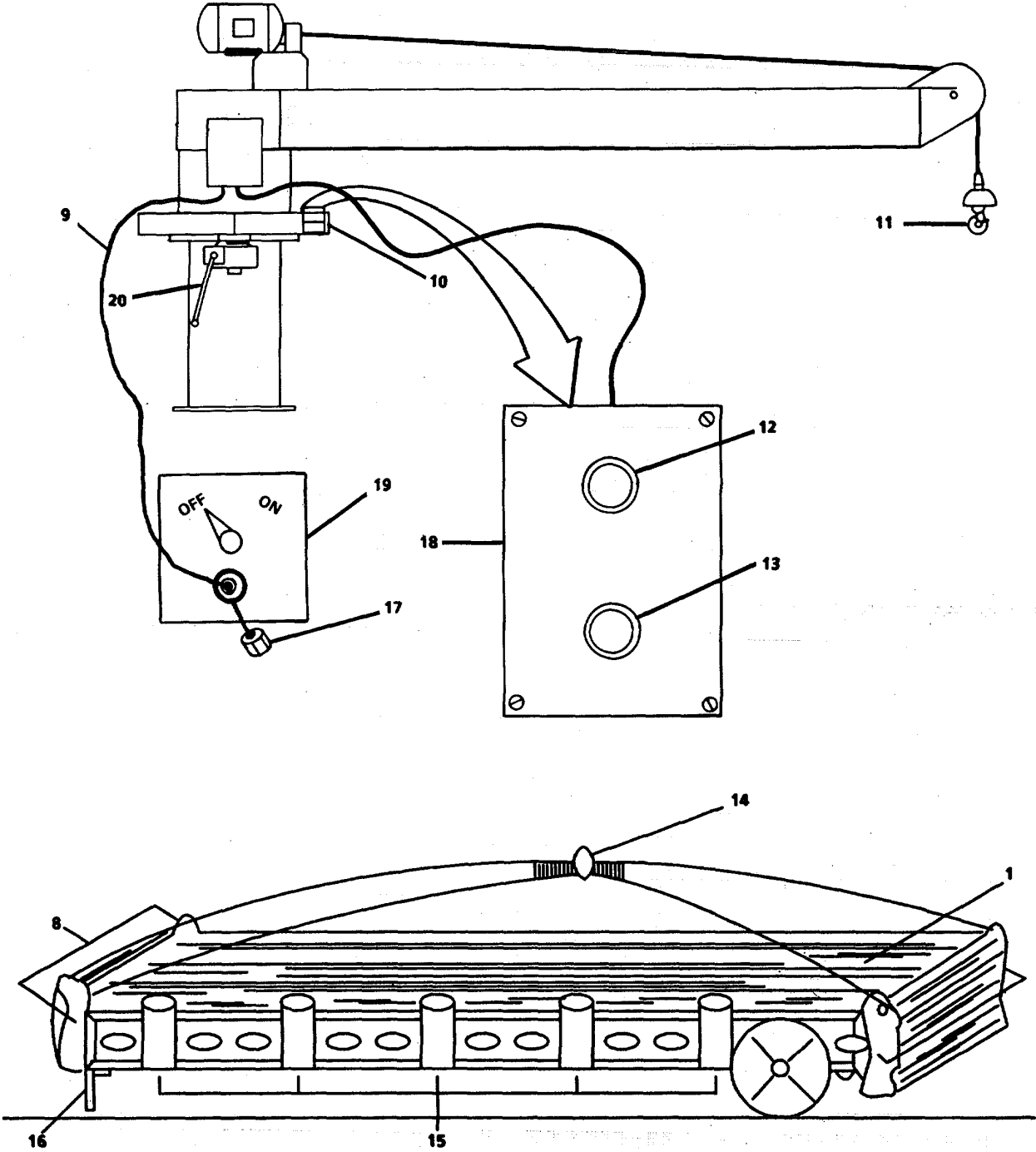

FIGURE 2-224. Rig Gangplank (Sheet 2 of 3).

**LEGEND**

- |                           |                      |
|---------------------------|----------------------|
| 1. GANG PLANK             | 11. CRANE HOOK       |
| 2. WING-TYPE NUT          | 12. UP               |
| 3. BRACKET                | 13. DOWN             |
| 4. GANG PLANK GUIDE RAILS | 14. LIFTING SLING    |
| 5. GANG PLANK GUIDE RAILS | 15. TUBE SLOTS       |
| 6. GANG PLANK GUIDE RAILS | 16. CONNECTOR        |
| 7. WHEELS                 | 17. WATER TIGHT CAP  |
| 8. CONNECTOR END          | 18. REMOTE CONTROL   |
| 9. POWER CORD             | 19. MOTOR CONTROLLER |
| 10. CRADLE                | 20. HAND CRANK       |

*FIGURE 2-224. Rig Gankplank (Sheet 3 of 3).*

**NOTE**

Attach and secure two required lengths of guideline to each end of gangplank to assist crew members in positioning gangplank into place.

- (8) Press DOWN (13) to lower CRANE HOOK (11); attach CRANE HOOK (11) to LIFTING SLING (14).

**WARNING**

All personnel must stand clear and out from under gangway during lifting operations.

- (9) Using crane to lift GANGPLANK (1), position CONNECTOR END (8) of GANGPLANK (1) towards selected GANGPLANK GUIDE RAIL (4, 5, or 6).

**NOTE**

Several crew members must be stationed at selected gangplank guide rail of LSU and on each side of gangplank to assist in guiding gangplank into the selected gangplank guide rail. Also several crew members are to be stationed on the dock (or vessel) where LSU will be tied.

**WARNING**

During placement of gangplank, crew members must at all times observe and exercise shipboard safety.

- (10) Press DOWN (13) to lower GANGPLANK (1), keeping it parallel to deck, to height that crew can use guidelines and sides of GANGPLANK (1) to move it into position.
- (11) Position GANGPLANK (1) so wheels end is pointing in direction of selected GANGPLANK GUIDE RAILS (4, 5, or 6).
- (12) Press DOWN (13) to slowly lower GANGPLANK (1) with LCU crew members guiding GANGPLANK (1) towards GANGPLANK GUIDE RAILS (4, 5, or 6) as crew members on deck (or vessels) use guidelines to pull GANGPLANK (1) towards them.
- (13) When GANGPLANK CONNECTOR END (8) is above GANGPLANK GUIDE RAIL (4, 5, or 6), lower GANGPLANK (1) until GANGPLANK CONNECTOR END (8) fits into rails (4, 5, or 6); GANGPLANK is resting on deck; wheels are resting on dock (or vessel) LCU deck.
- (14) With GANGPLANK (1) in place, perform following:
  - (a) Remove CRANE HOOK (11).

**WARNING**

Ensure all personnel are clear of crane cable before raising.

- (b) Remove LIFTING SLING (14) and guidelines.
- (c) Secure GANGPLANK (1) by placing lines through each end slot and securing each line to LCU railing.
- (d) Place railings (one on each side of gangplank) in designated TUBE SLOTS (15).

**2-35. Equipment Condition Prior To Getting Underway.** Refer to standard operating procedures for presail checklist and perform all required procedures.

**2-36. Main Engine Shutdown**

- a. Allow main engines to idle for no longer than 3 minutes.
- b. In Engine Operating Station on the Engine Room Console (FIGURE 2-225), press STOP pushbuttons (1 and 2).
- c. Close all valves.

**2-37. Gyro Compass MARK 27 MOD 1 Shutdown**

- a. On Gyro Compass Mk 27 Mod 1 (FIGURE 2-226), set SELECTOR switch (1) to OFF position.
- b. At Power Panel EP103, set Mk 27 GYRO PWR CONV UNIT switch to OFF position.
- c. At Power Panel EP103, set MK 37 HEADING XMTR switch to OFF position.

**2-38. Fresh Water Piping System Shutdown**

a. Shutdown Fresh Water Piping System

- (1) In Engine Room on Fresh Water Motor Controller (P217) (FIGURE 2-227), press STOP pushbutton (2); set circuit breaker handle (1) to OFF position.
- (2) In Engine Room on Fresh Water Motor Controller (P218), press STOP pushbutton (2); set circuit breaker handle (1) to OFF position.
- (3) Close FW-8, ISLN/SUCT-TK FW-6P (4, FIGURE 2-228).
- (4) Close FW-7, ISLN/SUCT-TK FW-6S (8).
- (5) Close FW-10, FW PUMP NO. 2 SUCT FM FW TKS (26).
- (6) Close FW-9, FW PUMP NO. 1 SUCT FR FW TKS (24).
- (7) On Main Switchboard (FIGURE 2-223), set HOT WATER HEATER circuit breaker (7) to the OFF position.
- (8) Open FW-80, PRESSURE TANK DRAIN (22, FIGURE 2-228).

**NOTE**

In Fresh Water Piping System all other valves are for equipment repair or fresh water use.

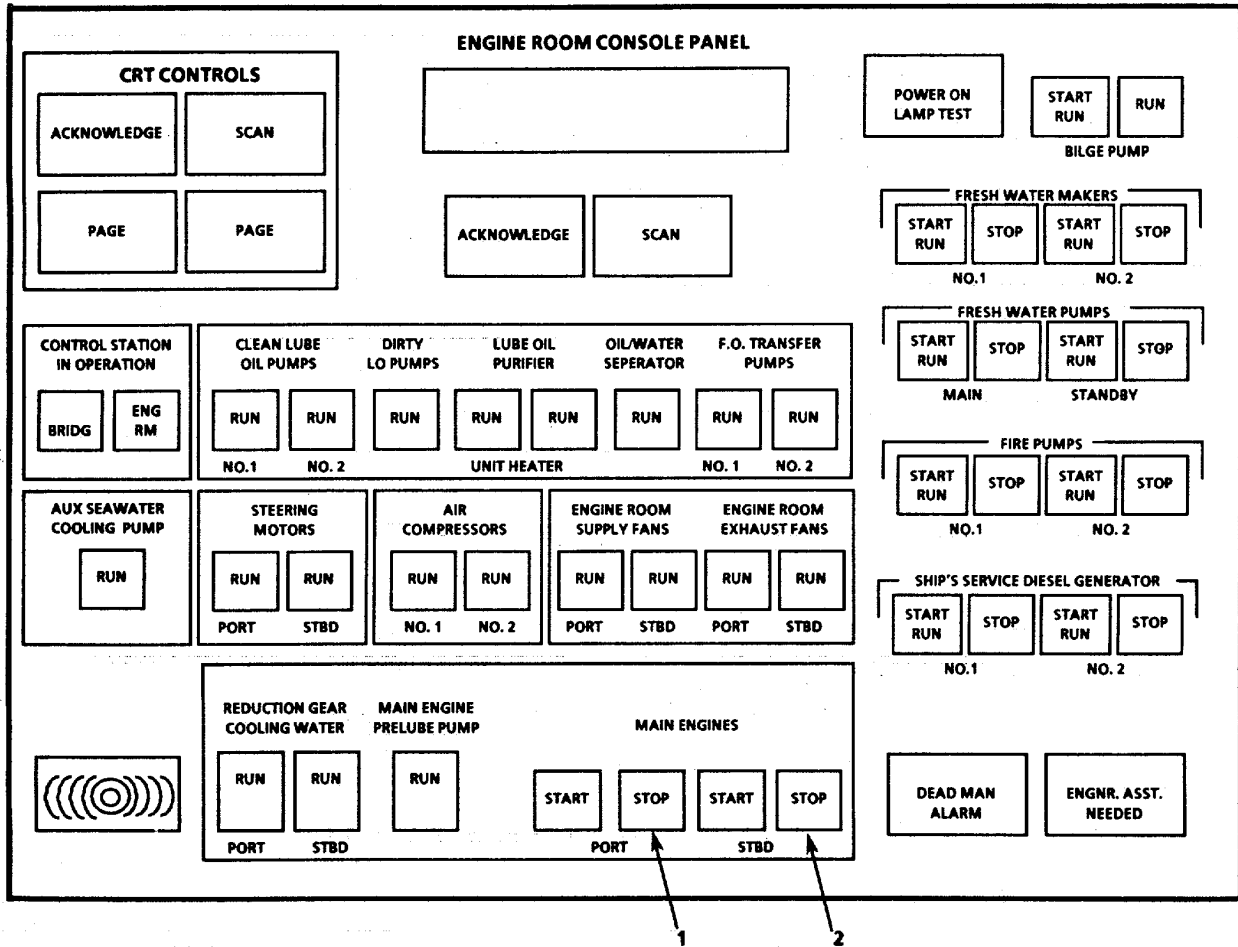

**LEGEND**

- 1. MN ENG PORT STOP
- 2. MN ENG STBD STOP

FIGURE 2-225. Engine Operating Station Console.

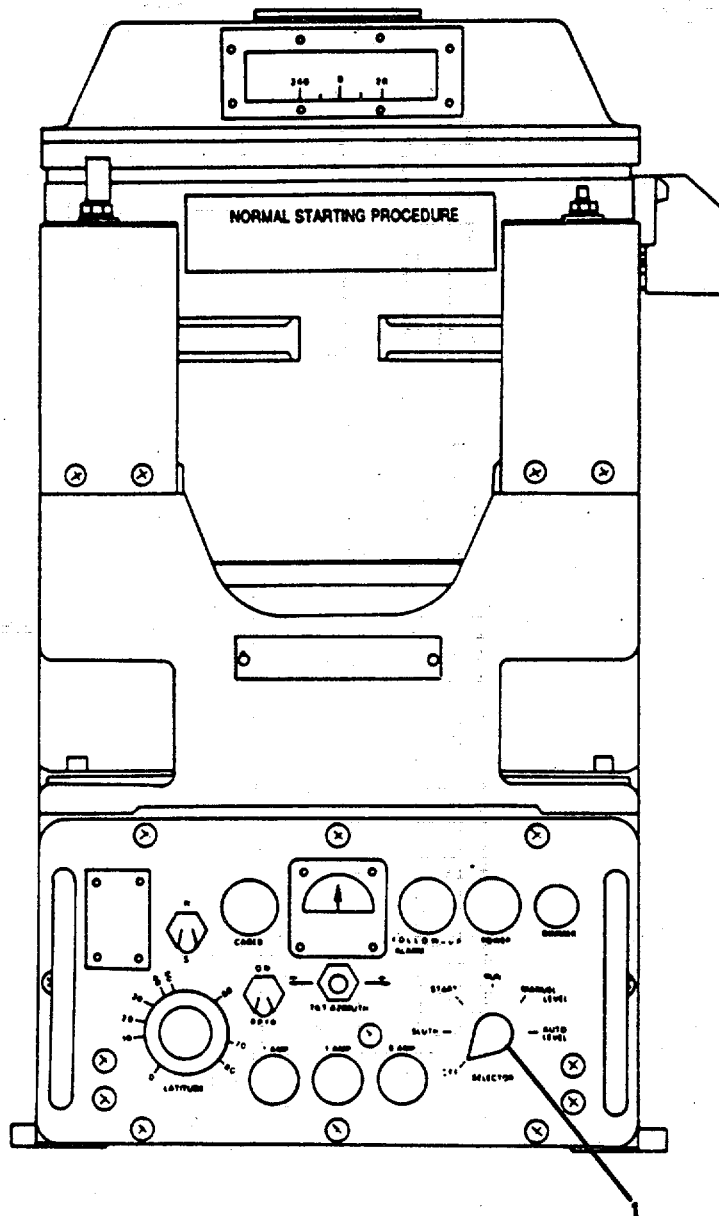

**LEGEND**  
**1. SELECTOR**

FIGURE 2-226. Gyro Compass Mk 27 Mod 1 Electronic Control Panel.



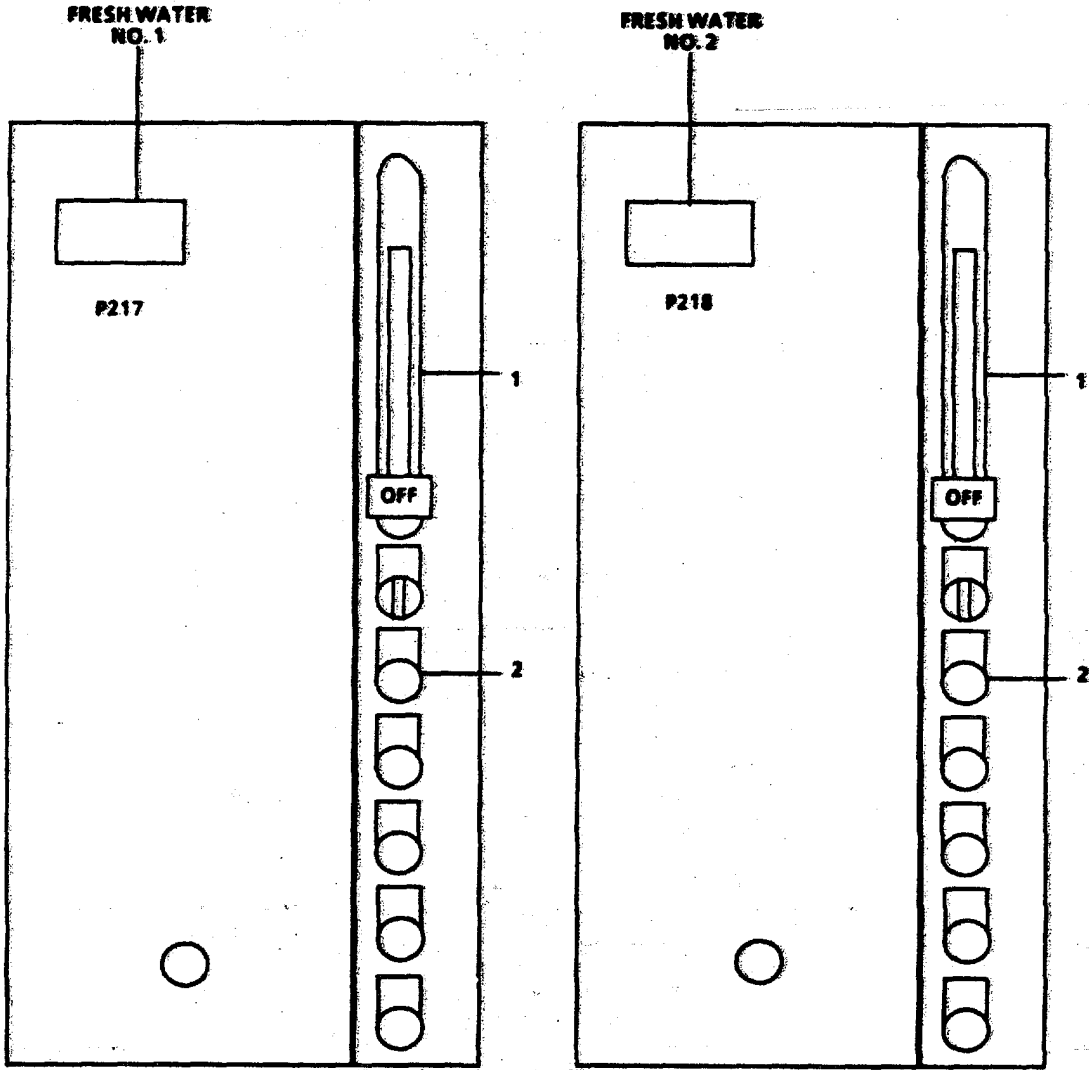

**LEGEND**

- 1. CIRCUIT BREAKER HANDLE
- 2. STOP PUSH BUTTON



FIGURE 2-227. Fresh Water Motor Controller.

Change 2 2-592

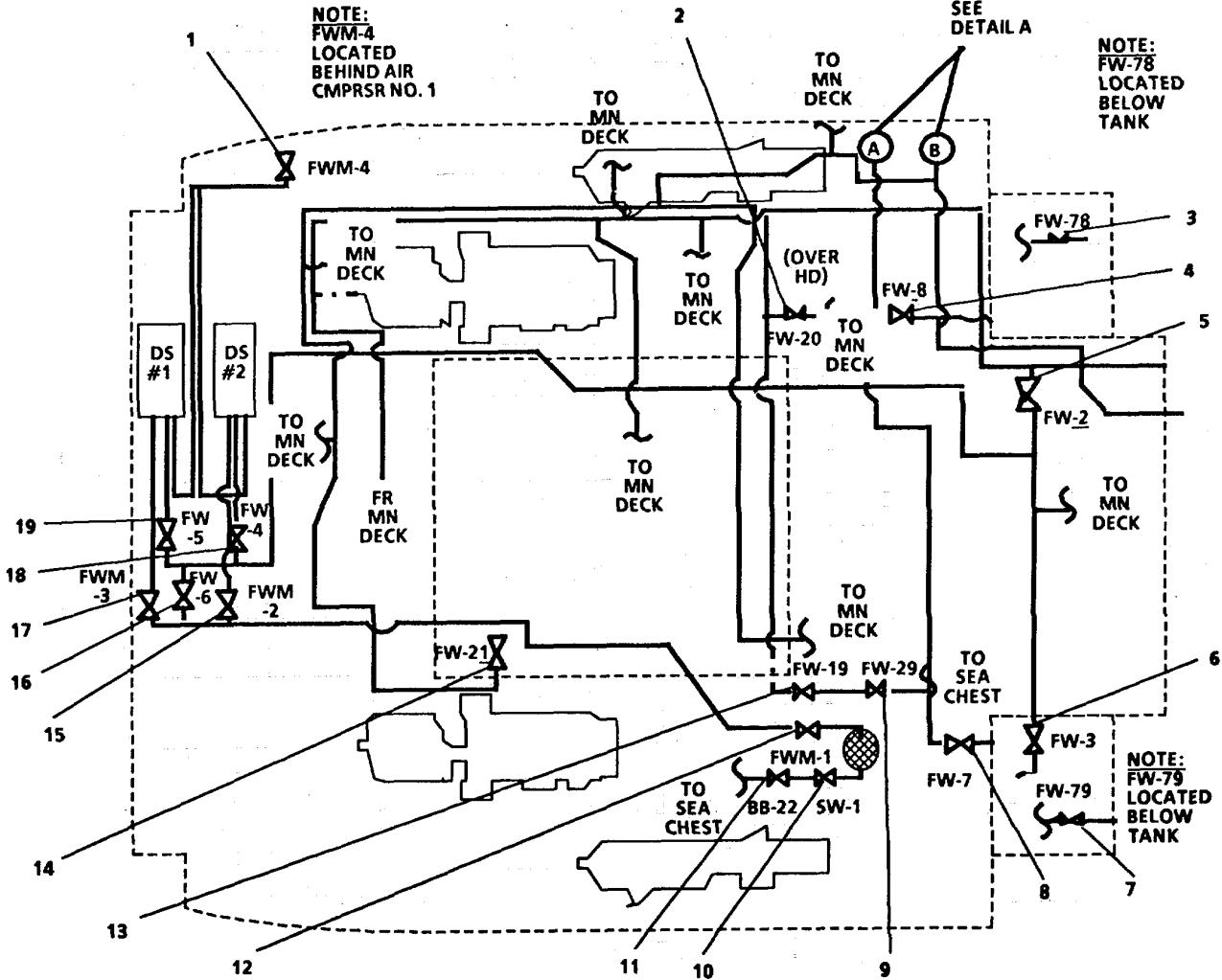

FIGURE 2-228. Fresh Water Piping System (Sheet 1 of 8).

DETAIL A

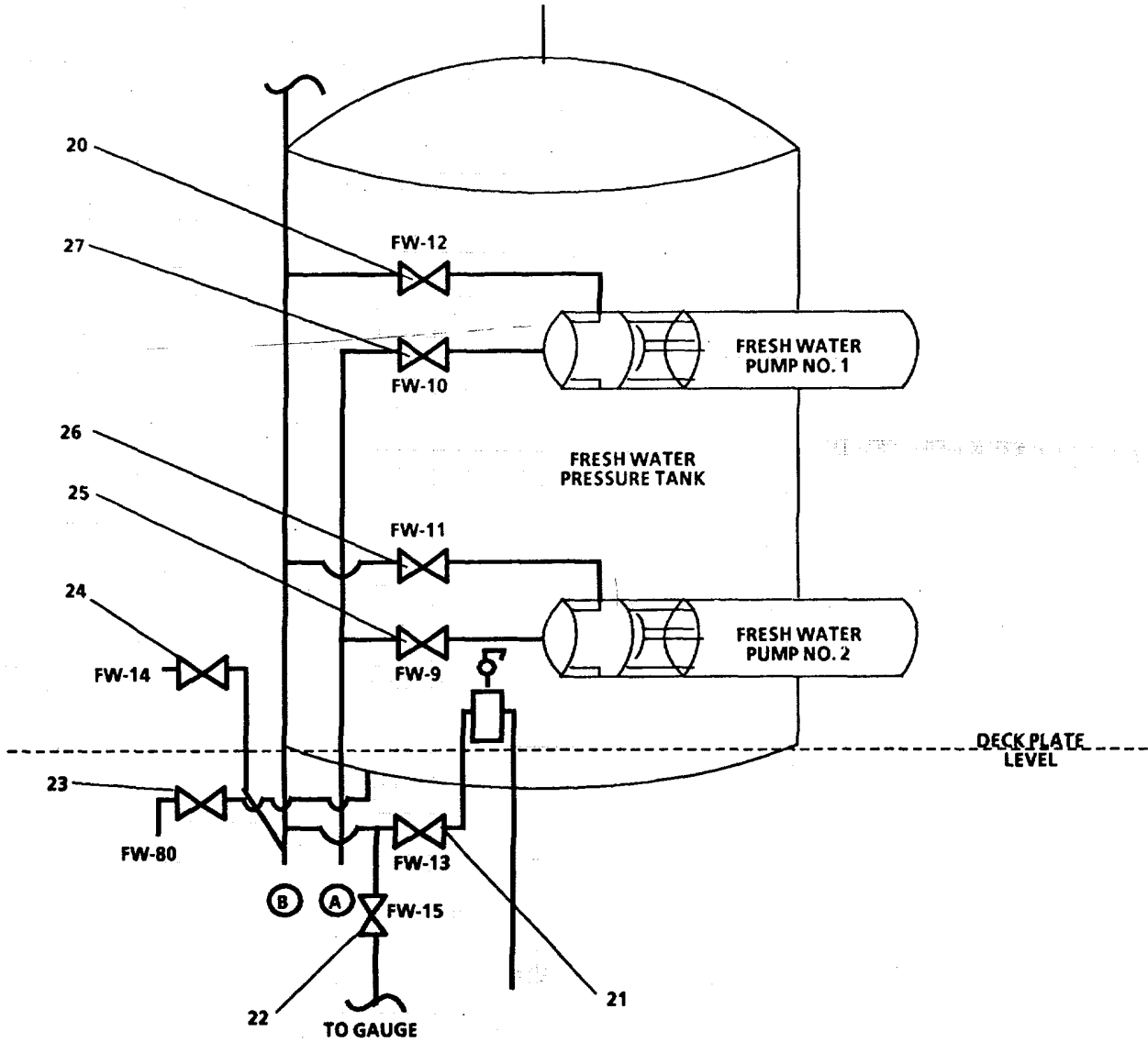
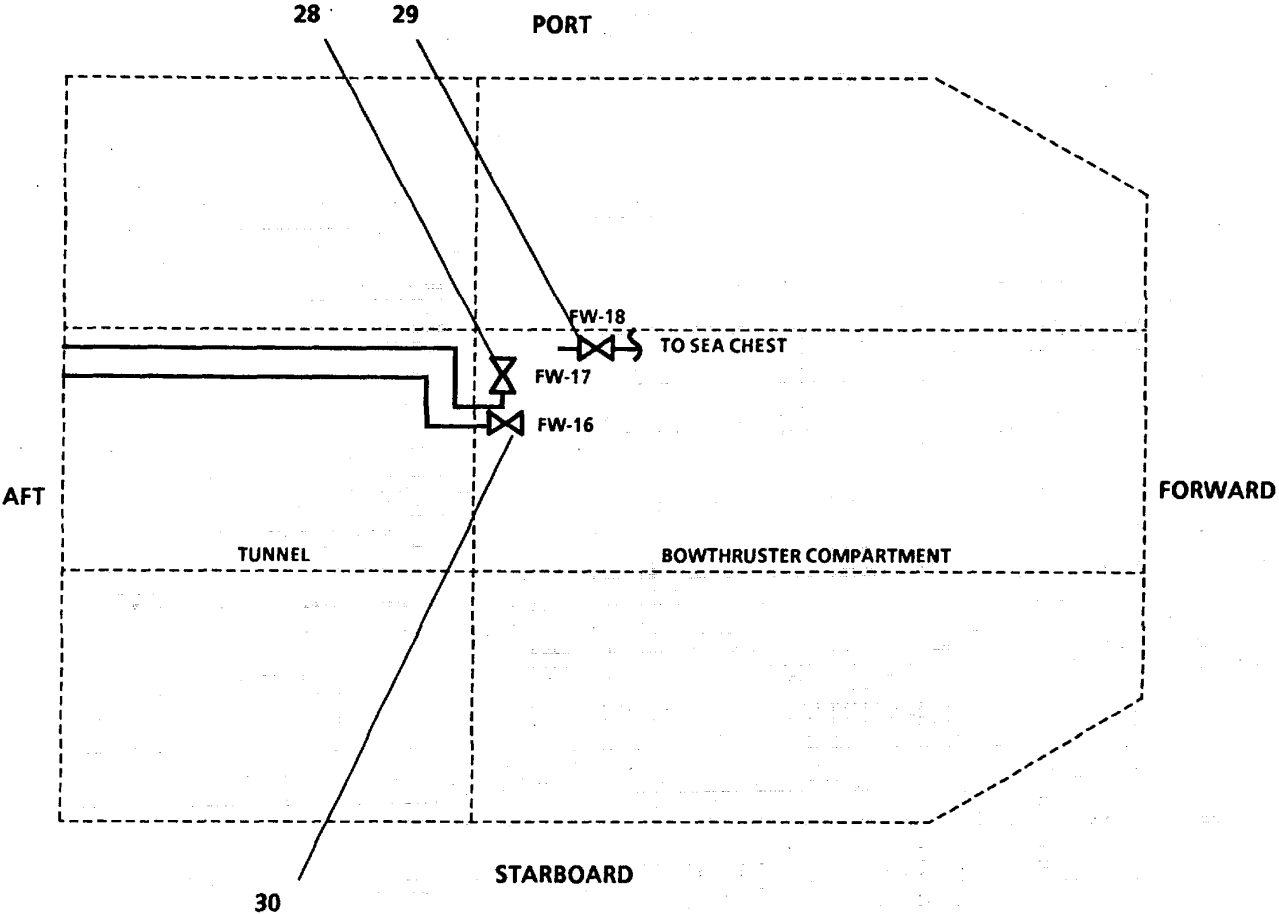

FIGURE 2-228. Fresh Water Piping System (Sheet 2 of 8).



**Below Main Deck (Tunnel and Bowthruster Compartment)**

FIGURE 2-228. Fresh Water Piping System (Sheet 3 of 8).

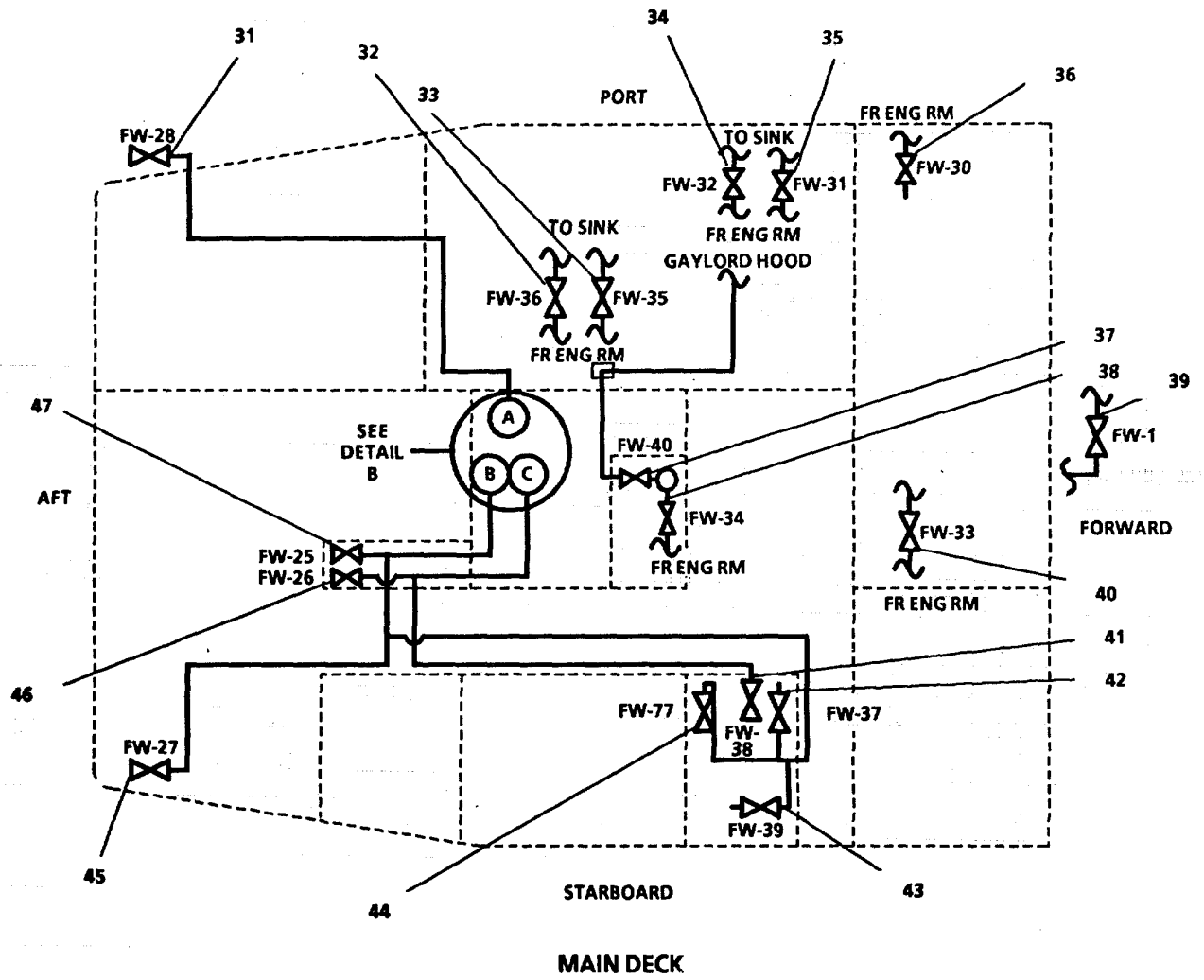

FIGURE 2-228. Fresh Water Piping System (Sheet 4 of 8).

DETAIL B

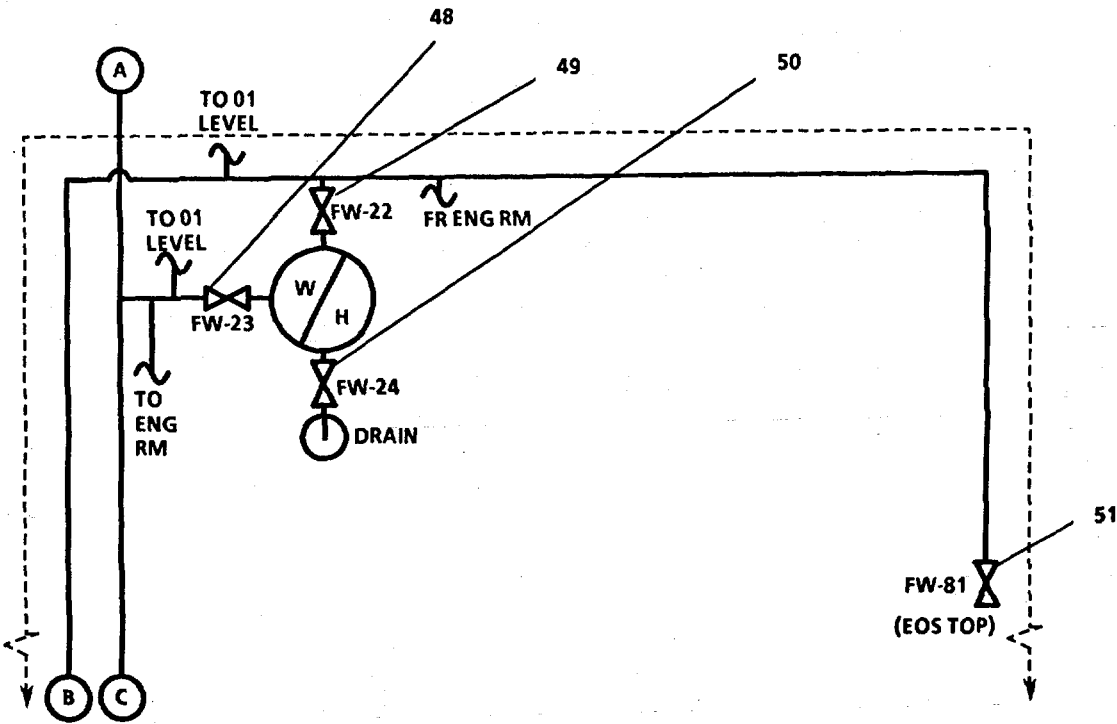

FIGURE 2-228. Fresh Water Piping System (Sheet 5 of 8).

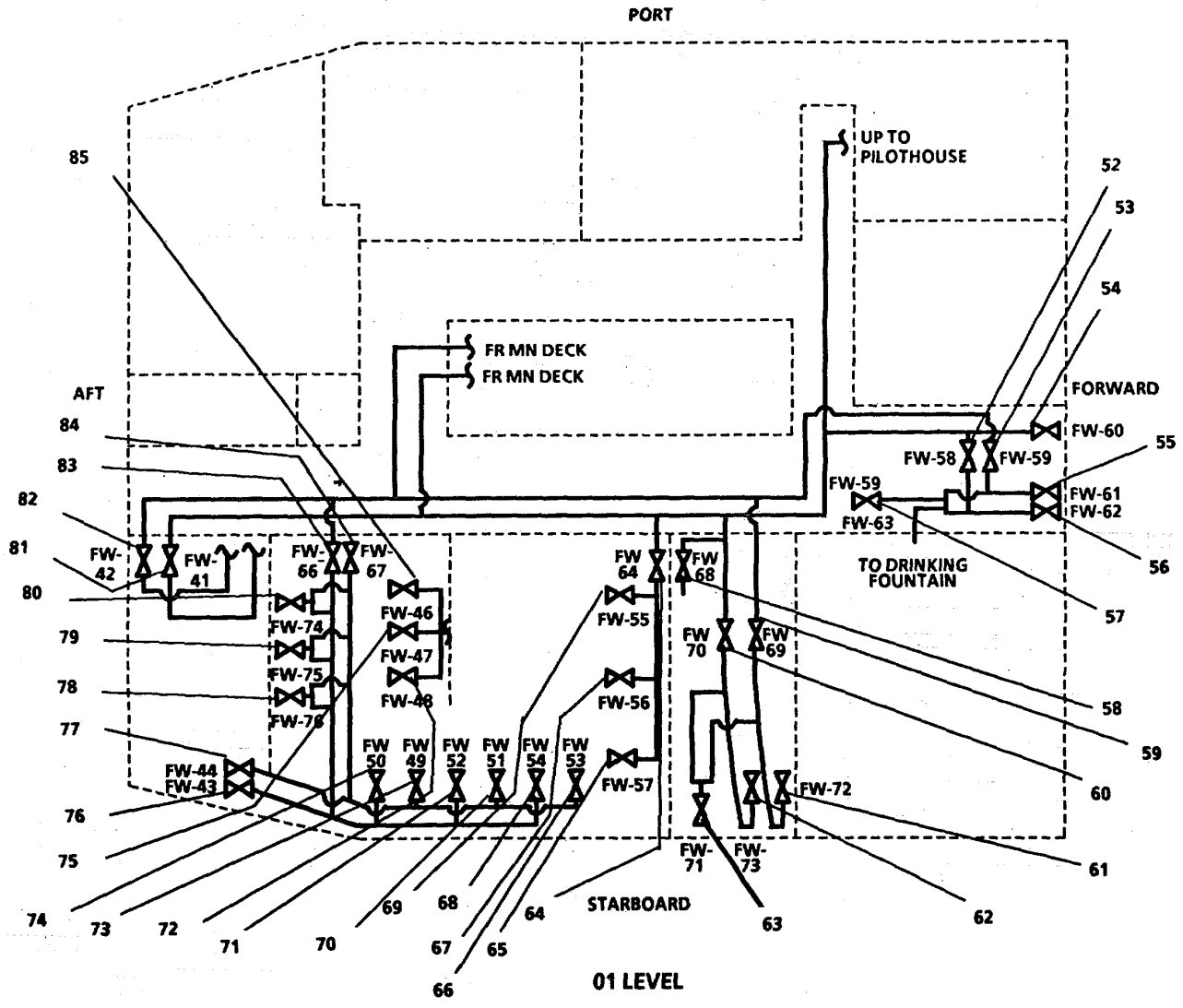
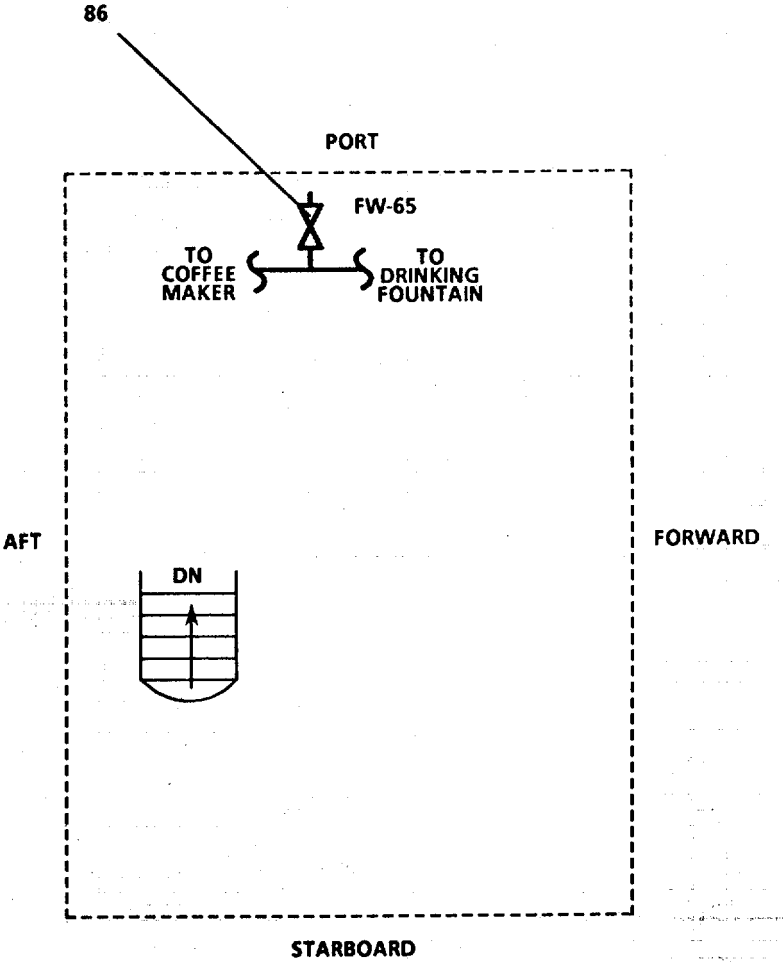

FIGURE 2-228. Fresh Water Piping System (Sheet 6 of 8).



**PILOTHOUSE**

FIGURE 2-228. Fresh Water Piping System (Sheet 7 of 8).



**LEGEND**

1. FWM-4, BRINE OVBD DISCH
2. FW-20, HOT FW TO DISHWASHER
3. FW-78, DRAIN-TK FW-6P
4. FW-8, ISLN/SUCT-TK FW-6P
5. FW-2, FILL ISLN-TK FW-6P
6. FW-3, FILL ISLN-TK FW-6S
7. FW-79, DRAIN-TK FW-6S
8. FW-7, ISLN/SUCT-TK FW-6S
9. FW-29, SEA CHEST-HOT FW CONNECTION
10. SW-1, SUPPLY TO PUMP
11. BB-22, ISLN-SEA CHEST
12. FWM-1, ISLN-SW SUPPLY TO FW MAKERS
13. FW-19, HOT FW HOSE CONN
14. FW-21, COLD FW TO DF & COFFEE MAKER-ENG RM
15. FWM-2, SW SUPPLY TO FW MAKER NO. 2
16. FW-6, FW SAMPLE STA
17. FWM-3, SW SUPPLY TO FW MAKER NO. 1
18. FW-4, FW MAKER NO. 2 SUPPLY TO FW TKS
19. FW-5, FW MAKER NO. 1 SUPPLY TO FW TKS
20. FW-12, FW PUMP NO. 2 DISCH
21. FW-13, FW PRESS TK ISLN
22. FW-15, CO PRESS GAGE-FW SYS
23. FW-80, PRESSURE TANK DRAIN
24. FW-14, COLD FW HOSE CONN
25. FW-9, FW PUMP NO. 1 SUCT FR FW TANKS
26. FW-11, FW PUMP NO. 1 DISCH
27. FW-10, FW PUMP NO. 2 SUCT FR FW TKS
28. FW-17, HOT FW HOSE CONN
29. FW-18, SEA CHEST - HOT FW CONN
30. FW-16, COLD FW HOSE CONN
31. FW-28, HOT FW WASHDOWN
32. FW-36, HOT FW TO AFT GALY SINK
33. FW-35, COLD FW TO AFT GALY SINK
34. FW-32, HOT FW TO FWD GALY SINK
35. FW-31, COLD FW TO FWD GALY SINK
36. FW-30, COLD FW TO DF (MESS DK)
37. FW-40, GAYLORD PUMP DISCH
38. FW-34, COLD FW TO GAYLORD HOOD PUMP
39. FW-1, FILL CONN-FW TKS
40. FW-33, COLD FW TO BVGE & COFFEE MAKER (MESS DK)
41. FW-38, HOT FW TO SICKBAY SINK
42. FW-37, COLD FW TO SICKBAY SINK
43. FW-39, SUPPLY TO WC
44. FW-77, SUPPLY TO SH
45. FW-27, COLD FW HOSE CONN
46. FW-26, HOT FW TO CG LKR SINK
47. FW-25, COLD FW TO CG LKR SINK
48. FW-23, HOT FW DISCH FR WTR HTR
49. FW-22, COLD FW TO WTR HTR
50. FW-24, WTR HTR DRAIN
51. FW-81, EXP TK FILL
52. FW-58, COLD FW ISLN
53. FW-59, HOT FW ISLN
54. FW-60, SUPPLY TO WC
55. FW-61, SUPPLY TO WC
56. FW-62, COLD FW TO SINK
57. FW-63, SUPPLY TO SH
58. FW-68, SUPPLY TO WC
59. FW-69, COLD FW ISLN
60. FW-70 ISLN-HOT FW
61. FW-72 COLD FW TO SINK
62. FW-73 HOT FW TO SINK
63. FW-71 SUPPLY TO SH
64. FW-64 ISLN-WC
65. FW-57, SUPPLY TO WC
66. FW-53, COLD FW TO SINK
67. FW-56, SUPPLY TO WC
68. FW-54, HOT FW TO SINK
69. FW-55 SUPPLY TO WC
70. FW-51 COLD FW TO SINK
71. FW-52 HOT FW TO SINK
72. FW-48 SUPPLY TO URINAL
73. FW-49 COLD FW TO SINK
74. FW-50 HOT FW TO SINK
75. FW-47 SUPPLY TO URINAL
76. FW-43 COLD FW TO WASHER
77. FW-44 HOT FW TO WASHER
78. FW-76 SUPPLY TO SH
79. FW-75, SUPPLY TO SH
80. FW-74, SUPPLY TO SH
81. FW-41, COLD FW TO LAU SINK
82. FW-42, HOT FW TO LAU SINK
83. FW-66, ISLN-HOT FW
84. FW-67, ISLN-COLD FW
85. FW-46, SUPPLY TO URINAL
86. FW-65, COLD FW TO DF

FIGURE 2-228. Fresh Water Piping System (Sheet 8 of 8).

b. Shutdown Water Purification System.

- (1) Set ON-OFF POWER switch (2, FIGURE 2-229) to OFF position.
- (2) Set S1 POWER SWITCH (1) to OFF position.
- (3) Close BB-22, ISLN-SEA CHEST (11).
- (4) Close FWM-1, ISLN-SW SUPPLY TO FW MAKERS (12, FIGURE 2-228).
- (5) Close FWM-2, SW SUPPLY TO FW MAKER NO. 2 (15).
- (6) Close FWM-3, SW SUPPLY TO FW MAKER NO. 1 (17).
- (7) Close FWM-4, BRINE OBVD DISCH (1).
- (8) Close FW-4, FW MAKER NO. 2 SUPPLY TO FW TKS (18).
- (9) Close FW-5, FW MAKER NO. 1 SUPPLY TO FW TANKS (19).
- (10) Close FW-3, FILL ISLN-TK FW-6S (6).
- (11) Close FW-2, FILL ISLN-TK FW-6P (5).

**2-39. Auxiliary Machinery Motor Control Center (FIGURE 2-230) Shutdown.**

- a. Press STOP pushbutton (2), set P205-9 circuit breaker (1) to OFF position.
- b. Press STOP pushbutton (4), set P205-10 circuit breaker (3) to OFF position.
- c. Press STOP pushbutton (27), set P205-11 circuit breaker (28) to OFF position
- d. Press STOP pushbutton (25), set P205-12 circuit breaker (26) to OFF position.
- e. Set P205-14A (23) and P205-14B circuit breakers (24) to OFF position.
- f. Set P205-13A (21) and P205-13B circuit breakers (22) to OFF position.
- g. Press STOP pushbutton (6), set P205-1 circuit breaker (5) to OFF position.
- h. Press STOP pushbutton (17), set P205-2 circuit breaker (20) to OFF position.
- i. Press STOP pushbutton (18), set P205-3 circuit breaker (19) to OFF position.
- j. Press STOP pushbutton (8), set P205-6 circuit breaker (7) to OFF position.
- k. Press STOP pushbutton (10), set P205-7 circuit breaker (9) to OFF position.
- l. Press STOP pushbutton (12), set P205-8 circuit breaker (11) to OFF position.
- m. Press STOP pushbutton (14), set P205-4 circuit breaker (13) to OFF position.
- n. Press STOP pushbutton (16), set P205-5 circuit breaker (15) to OFF position.

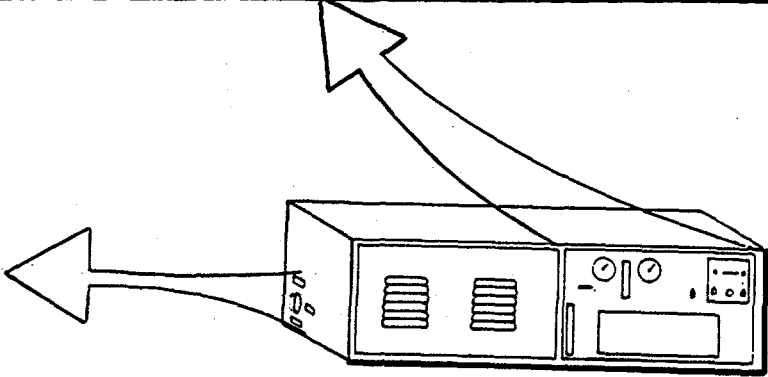
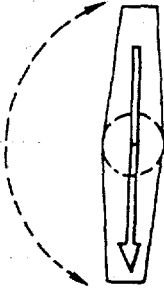
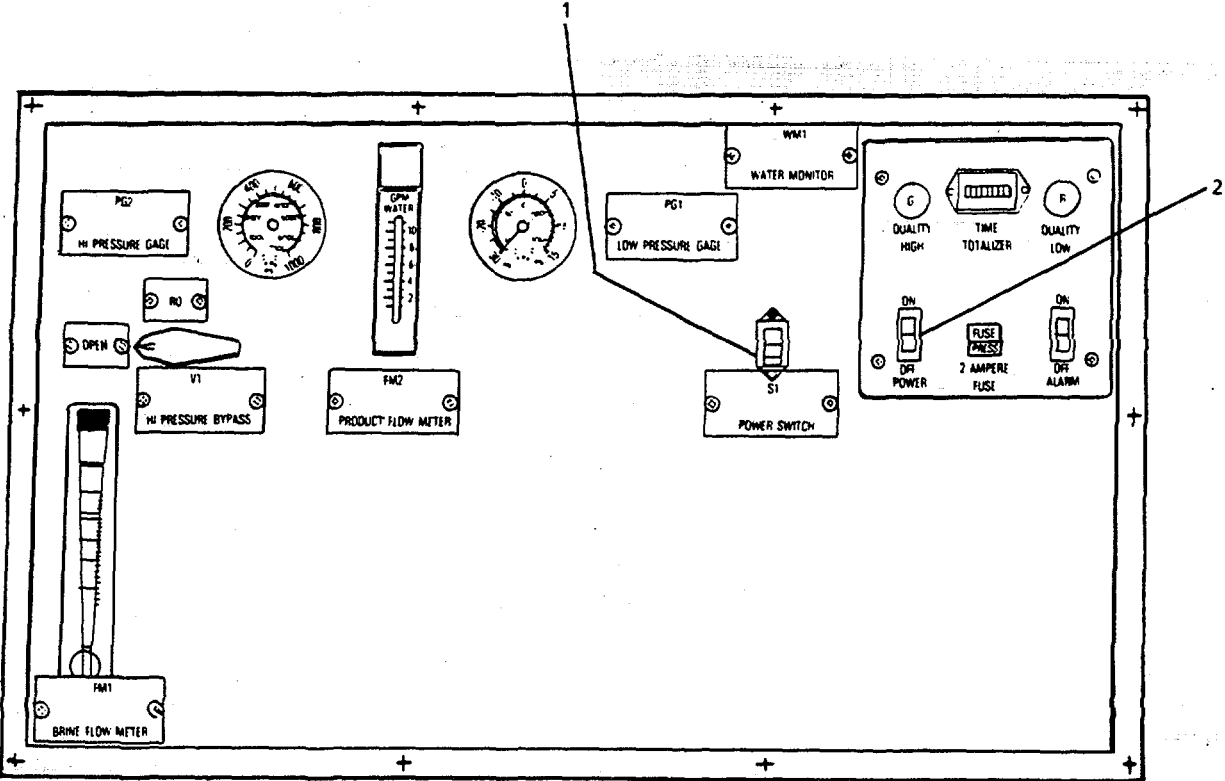

- LEGEND**
- 1. POWER SWITCH
  - 2. ON-OFF POWER SWITCH

FIGURE 2-229. Reverse Osmosis Desalinator.

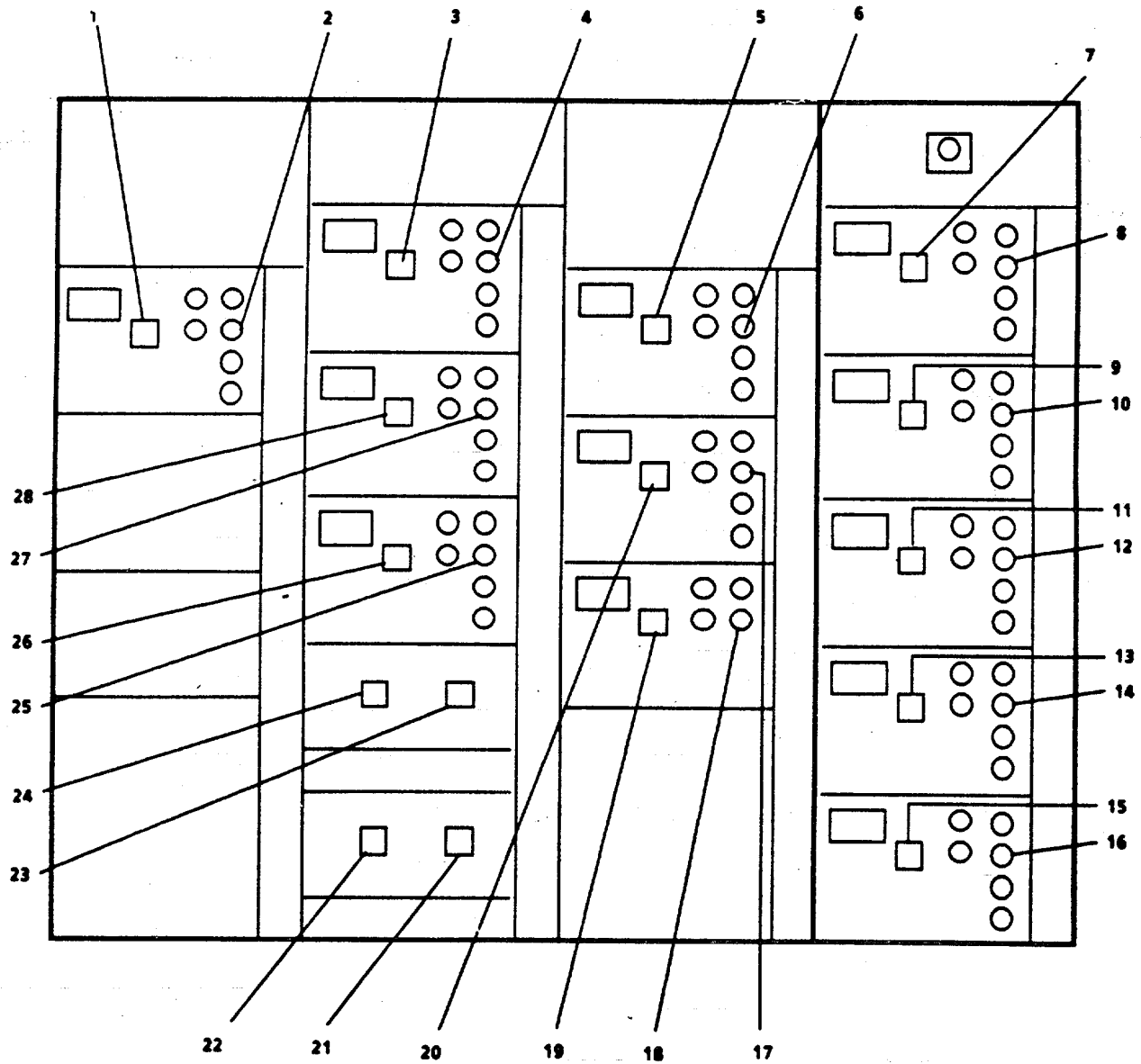

**LEGEND**

- |                     |                      |                      |                      |
|---------------------|----------------------|----------------------|----------------------|
| 1. P205-9           | 8. STOP PUSH BUTTON  | 15. P205-5           | 22. P205-13B         |
| 2. STOP PUSH BUTTON | 9. P205-7            | 16. STOP PUSH BUTTON | 23. P205-14A         |
| 3. P205-10          | 10. STOP PUSH BUTTON | 17. STOP PUSH BUTTON | 24. P205-14B         |
| 4. STOP PUSH BUTTON | 11. P205-8           | 18. STOP PUSH BUTTON | 25. STOP PUSH BUTTON |
| 5. P205-1           | 12. STOP PUSH BUTTON | 19. P205-3           | 26. P205-12          |
| 6. STOP PUSH BUTTON | 13. P205-4           | 20. P205-2           | 27. STOP PUSH BUTTON |
| 7. P205-6           | 14. STOP PUSH BUTTON | 21. P205-13A         | 28. P205-11          |

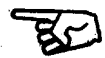

FIGURE 2-230. Auxiliary Machinery Motor Control Center.

**2-40. Compressed Air Piping System Shutdown (FIGURE 2-231).**

- a. Press STOP Push Button on each air compressor.
- b. Slowly open AIR RECEIVER DRAIN VALVES (42 and 45). Allow compressed air system to drain
- c. When all air pressure has been relieved, close AIR RECEIVER DRAIN VALVES (42 and 45)
- d. Close all open valves in the compressed air system.

**2-41. Emergency Generator and Switchboard Shutdown.**

- a. On Emergency Generator Diesel Control Panel (FIGURE 2-232), set RUN-OFF-AUTO switch (1) to OFF position.
- b. On Emergency Switchboard (FIGURE 2-233), set all circuit breakers to OFF position.

**2-42. Ship Service Diesel Generator Shutdown.**

- a. On Main Switchboard (FIGURE 2-234), press TRIP Push Button (1) and TRIP Push Button (2).
- b. On Main Switchboard, set all circuit breakers to OFF position; set all other switches of OFF position as required.
- c. On port and starboard Ship Service Diesel Generator and Control Panel (FIGURE 2-235), set EXCITATION switch (1) to OFF position.
- d. Set IDLE RUN switch (2) to IDLE position.
- e. Allow diesel to run for 3 minutes then set IDLE RUN switch (2) to OFF position.
- f. Close all valves in Fuel Oil Filter, Transfer, and Supply Piping System (FIGURE 2-236).
- g. Close all valves in SSDG Fresh Water Cooling Piping System (FIGURE 2-237).

**2-43. Fire Main and Foam Piping System Shutdown (FIGURE 2-238).**

- a. Operate and shutdown FOAM station No. 2 (pilothouse top) in accordance with paragraph 2-7d(2).
- b. Operate and shutdown fire monitors.
  - (1) Close FM-24, PORT FOAM MONITOR ISLN (11).
  - (2) Close FM-23, STBD FOAM MONITOR ISLN (12).
  - (3) Observe flow until sea water is output.
  - (4) Close isolation valve at monitor.

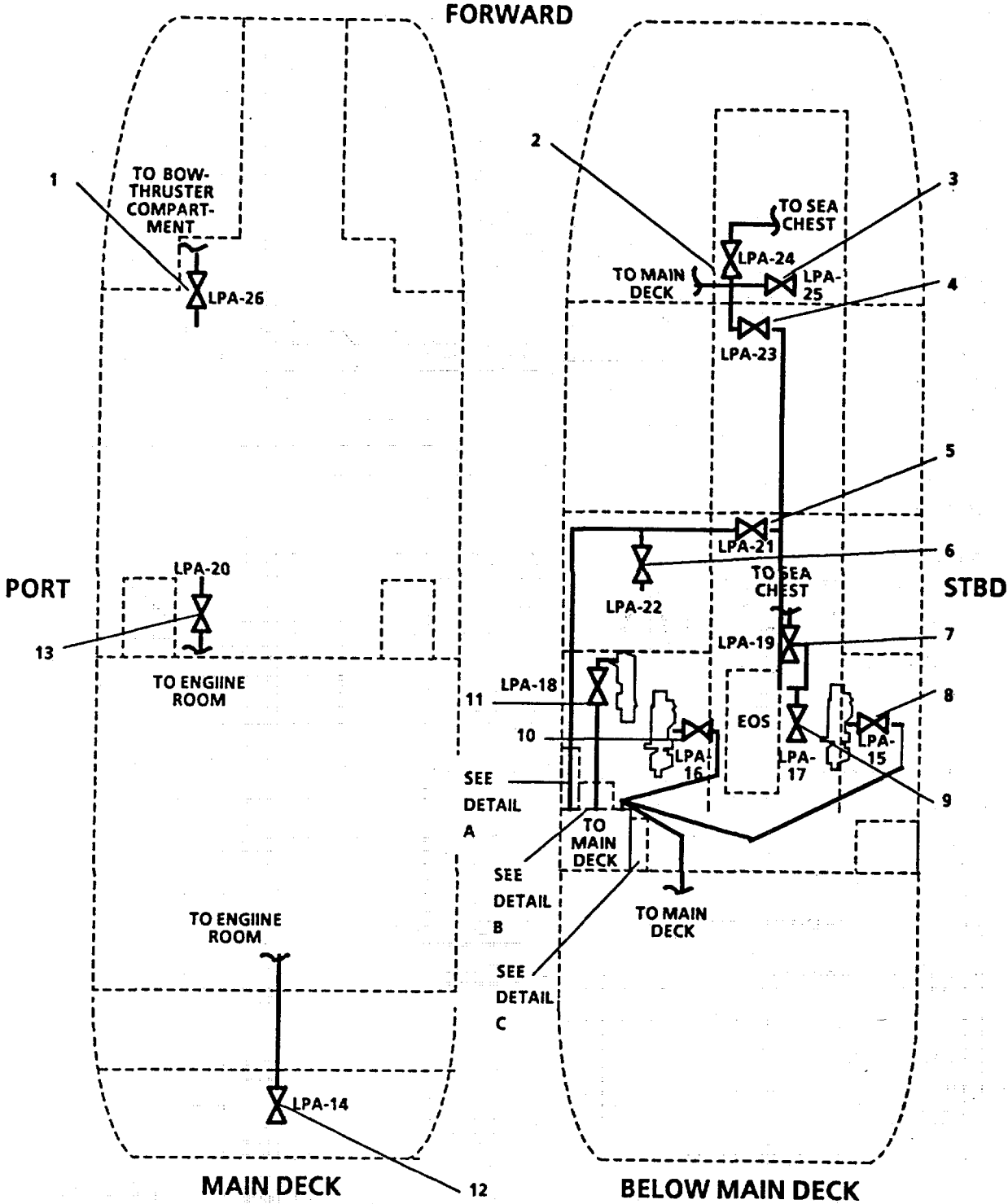

FIGURE 2-231. Compressed Air Piping System (Sheet 1 of 5).

DETAIL A

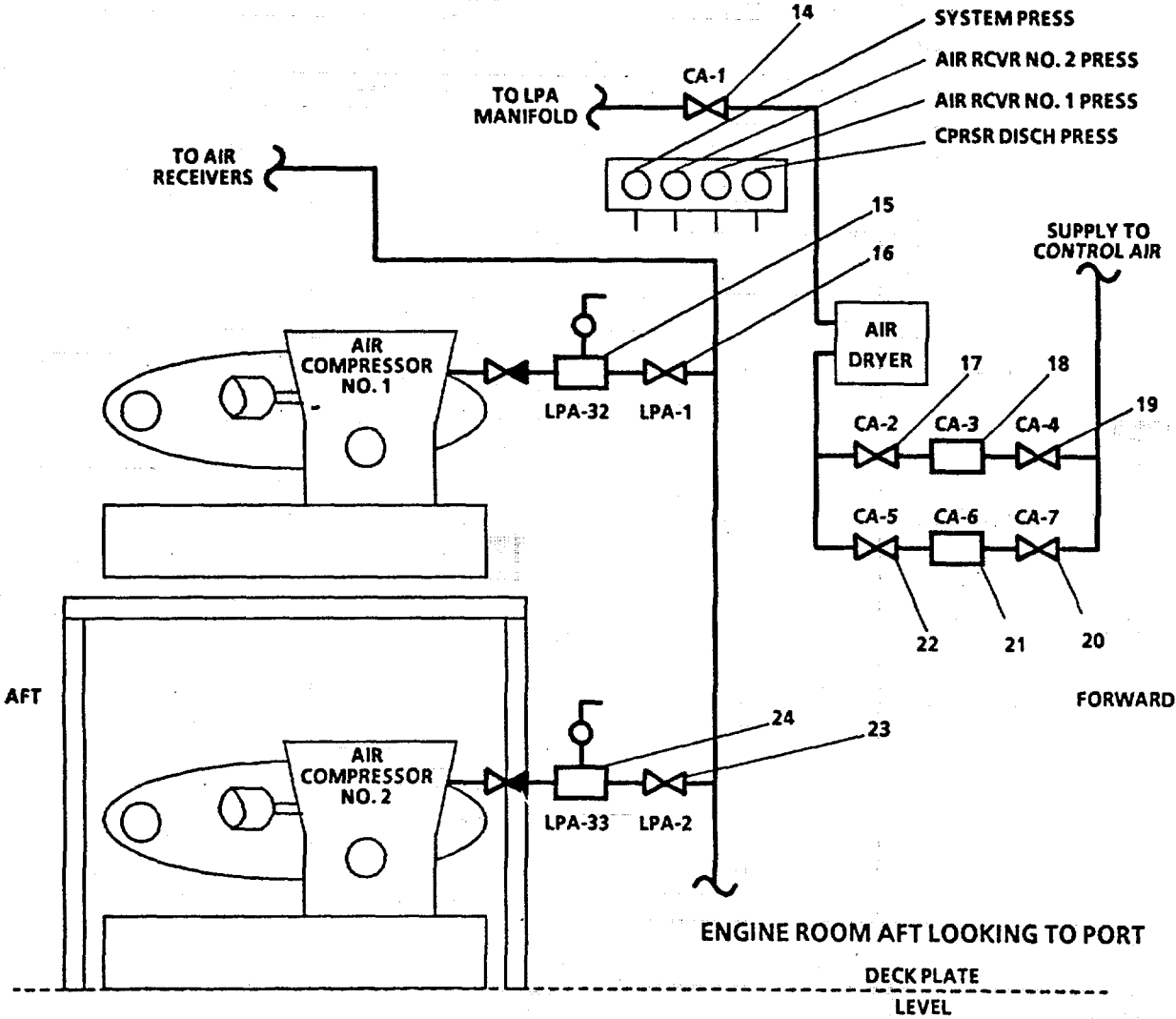
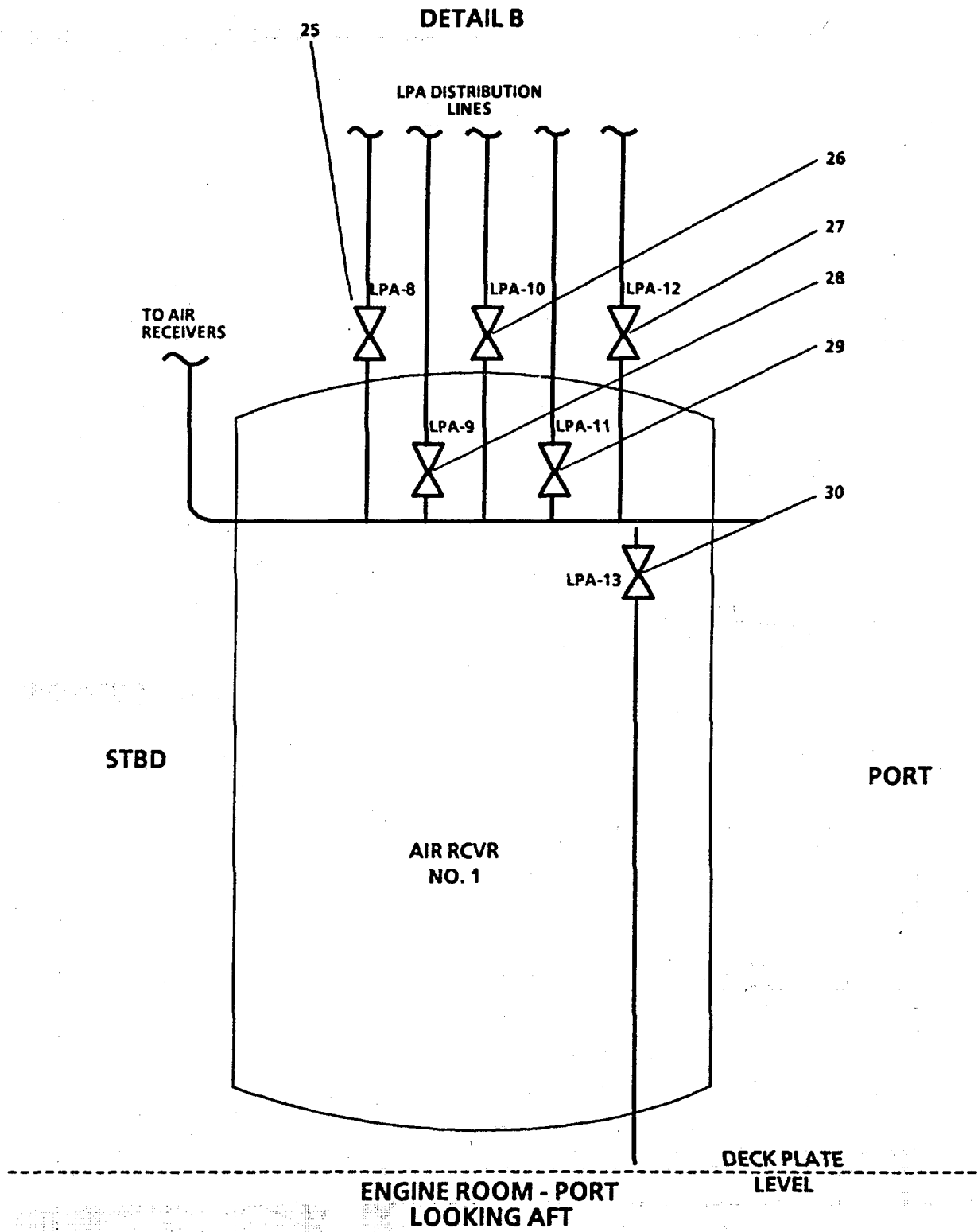

FIGURE 2-231. Compressed Air Piping System (Sheet 2 of 5).



**LEGEND**

28. LPA-12, SUPPLY TO SSDG PORT

FIGURE 2-231. Compressed Air Piping System (Sheet 3 of 5).



DETAIL C

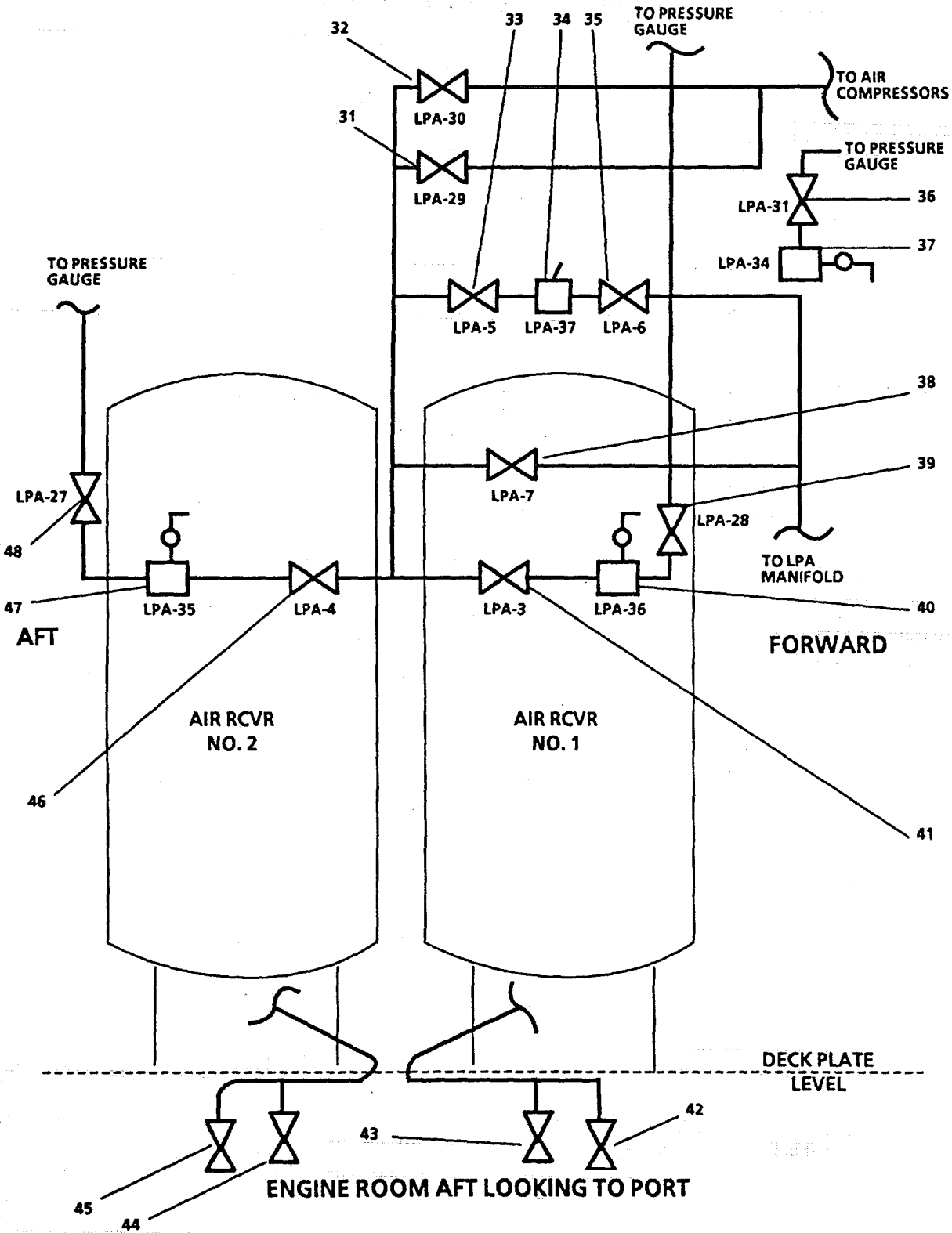
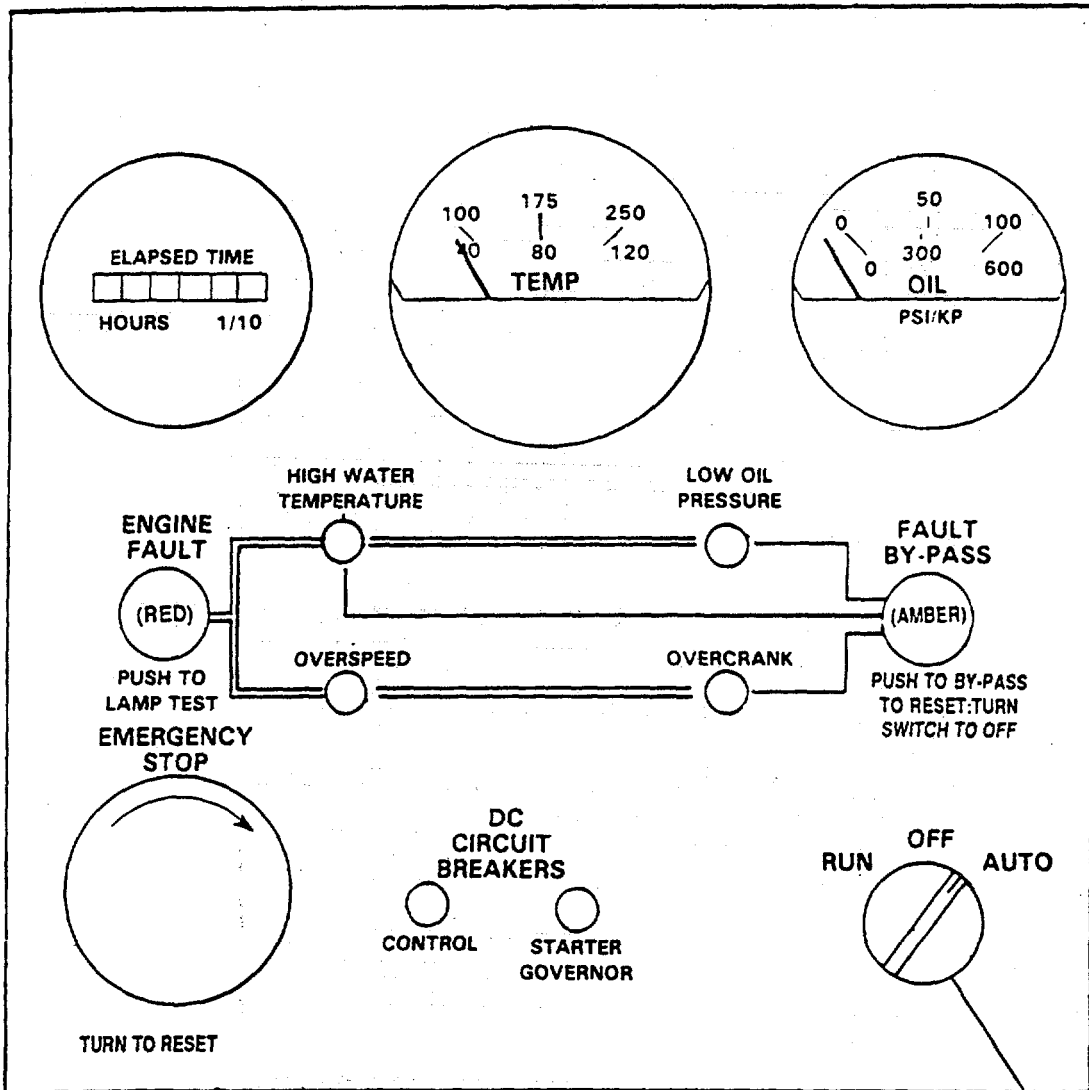

FIGURE 2-231. Compressed Air Piping System (Sheet 4 of 5).

**LEGEND**

- |  |   |
|--|---|
| 1. LPA-26, SUPPLY TO SVCE AIR          | 25. LPA-8, SUPPLY TO CONTROL AIR        |
| 2. LPA-24, SEA CHEST BLWDN             | 26. LPA-10, SUPPLY TO MN ENG-STBD       |
| 3. LPA-25, SUPPLY TO SVCE AIR          | 27. LPA-12, SUPPLY TO SSDG-PORT         |
| 4. LPA-23, SUPPLY TO FWD SVCE AIR      | 28. LPA-9, SUPPLY TO SVCE AIR           |
| 5. LPA-21, SUPPLY TO FWD SVCE AIR      | 29. LPA-11, SUPPLY TO MN ENG-STBD       |
| 6. LPA-22, SUPPLY TO SVCE AIR          | 30. LPA-13, MANIFOLD DRAIN              |
| 7. LPA-19, SEA CHEST BLWDN             | 31. LPA-29, TO AIR CPRSR UNLOADERS      |
| 8. LPA-15, SUPPLY TO MN ENG-STBD       | 32. LPA-30, PRESS SW                    |
| 9. LPA-17, SUPPLY TO SVCE AIR          | 33. LPA-5, SUPPLY TO PRESS RDCR         |
| 10. LPA-16, SUPPLY TO MN ENG-PORT      | 34. LPA-37, PRESS RDCR                  |
| 11. LPA-18, SUPPLY TO SSDG-PORT        | 35. LPA-6, SUPPLY TO MANIF              |
| 12. LPA-14, SUPPLY TO SVCE AIR         | 36. LPA-31, PRESS GAGE                  |
| 13. LPA-20, SUPPLY TO SVCE AIR         | 37. LPA-34, RELIEF VLV                  |
| 14. CA-1, CONTROL AIR CUTOUT           | 38. LPA-7, BYPASS TO MANF               |
| 15. LPA-32, RELIEF VLV-AIR CPRSR NO. 1 | 39. LPA-28, PRESS GAGE - AIR RCVR NO. 1 |
| 16. LPA-1, DISCH-AIR CPRSR NO. 1       | 40. LPA-36, RELIEF VLV-AIR RCVR NO. 1   |
| 17. CA-2, ISLN-SEP/RGLTR               | 41. LPA-3, ISLN-AIR RCVR NO. 1          |
| 18. CA-3, SEP/RGLTR                    | 42. AIR RECEIVER DRAIN                  |
| 19. CA-4, SUPPLY TO CONTROL AIR        | 43. ISOLATION VALVE-AIR WATER SEPARATOR |
| 20. CA-7, SUPPLY TO CONTROL AIR        | 44. ISOLATION VALVE-AIR WATER SEPARATOR |
| 21. CA-6, SEP/RGLTR                    | 45. AIR RECEIVER DRAIN                  |
| 22. CA-5, ISLN-SEP/RGTR                | 46. LPA-4, ISLN-AIR RCVR NO. 2          |
| 23. LPA-2, DISCH-AIR CPRSR NO. 2       | 47. LPA-35, RELIEF VLV-AIR RCVR NO. 2   |
| 24. LPA-33, RELIEF VLV-AIR CPRSR NO. 2 | 48. LPA-27, PRESS GAGE-AIR RCVR NO. 2   |

FIGURE 2-231. Compressed Air Piping System (Sheet 5 of 5).



**LEGEND**  
 1. RUN-OFF AUTO SWITCH

FIGURE 2-232. Emergency Generator Diesel Control Panel.

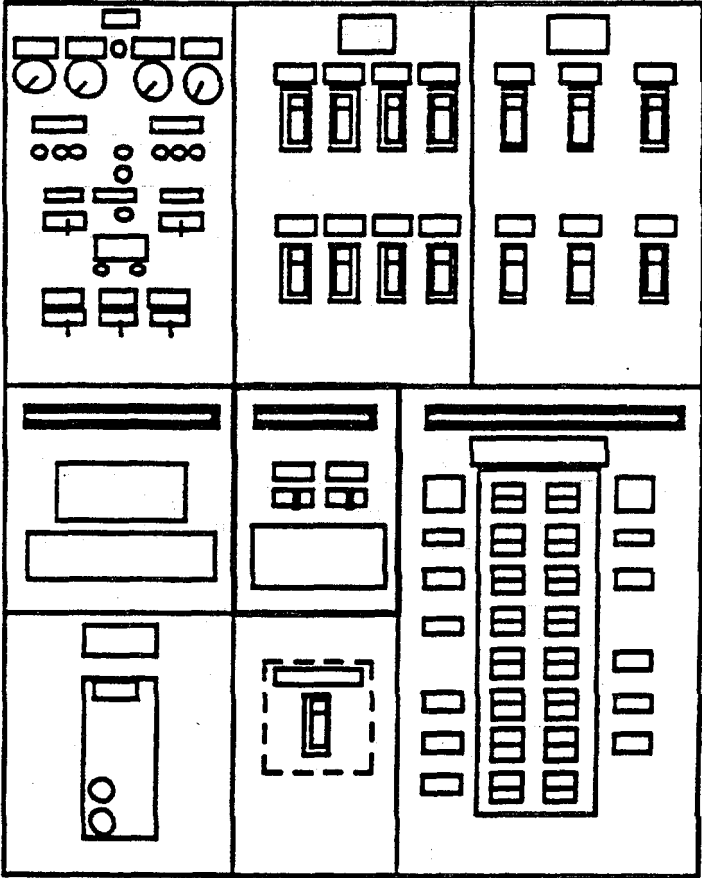
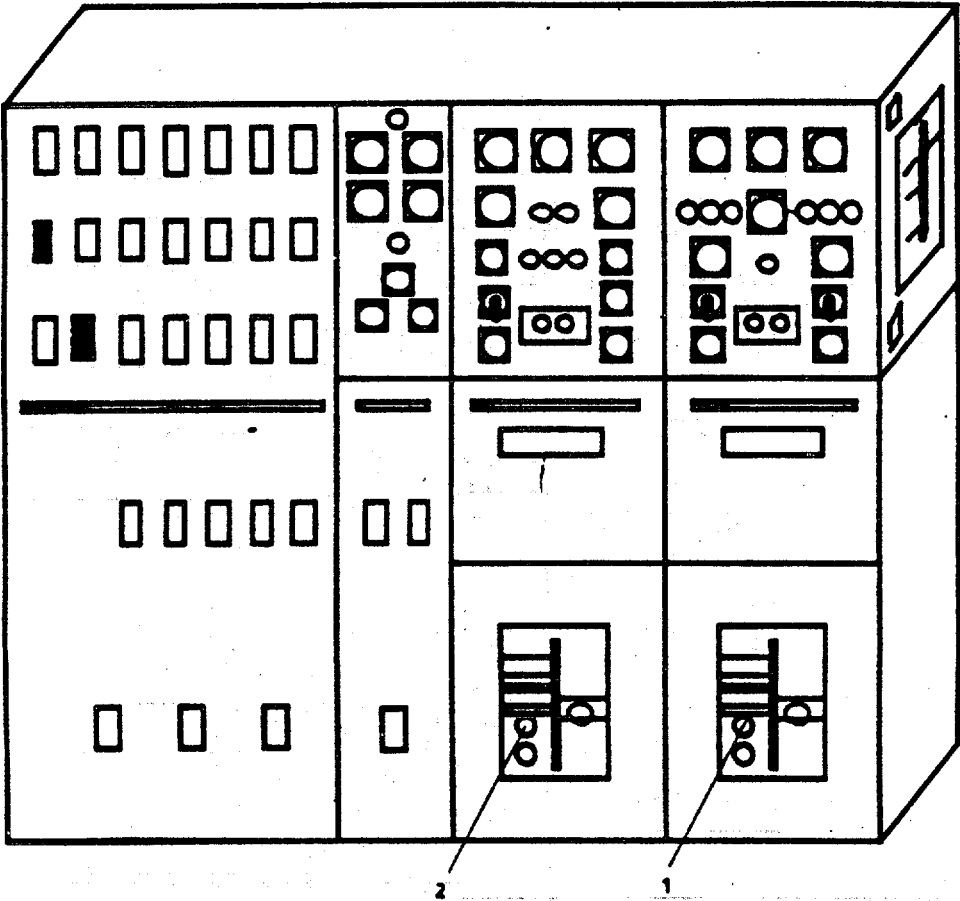

FIGURE 2-233. Emergency Switchboard.



- LEGEND**
- 1. TRIP PUSH BUTTON
  - 2. TRIP PUSH BUTTON

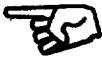
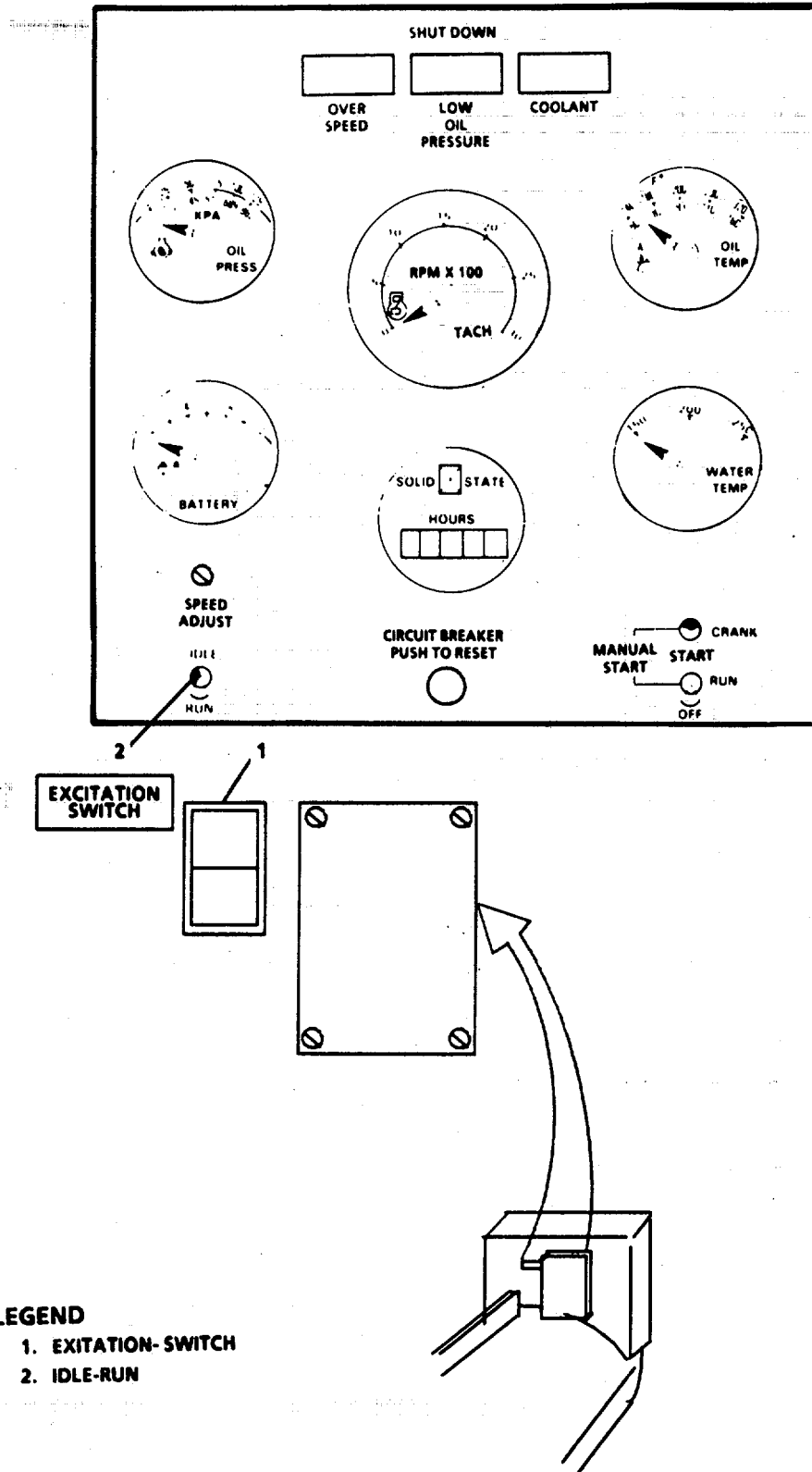

FIGURE 2-234. Main Switchboard.

Change 2 2-612



- LEGEND**
- 1. EXCITATION-SWITCH
  - 2. IDLE-RUN

FIGURE 2-235. Ship Service Diesel Generator and Control Panel.

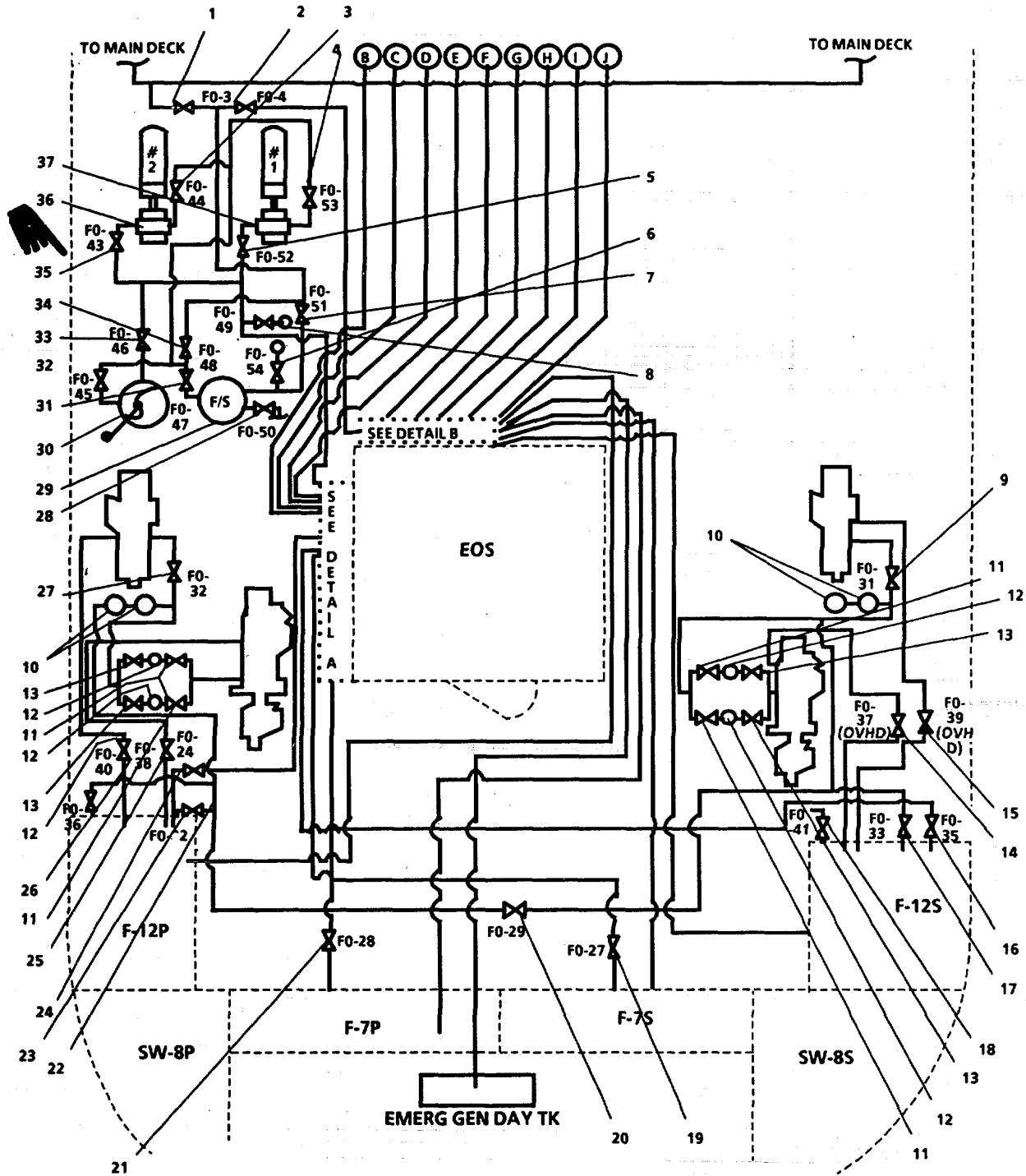

FIGURE 2-236. Fuel Oil Filter, Transfer, and Supply Piping System (Sheet 1 of 6).

Change 1 2-614

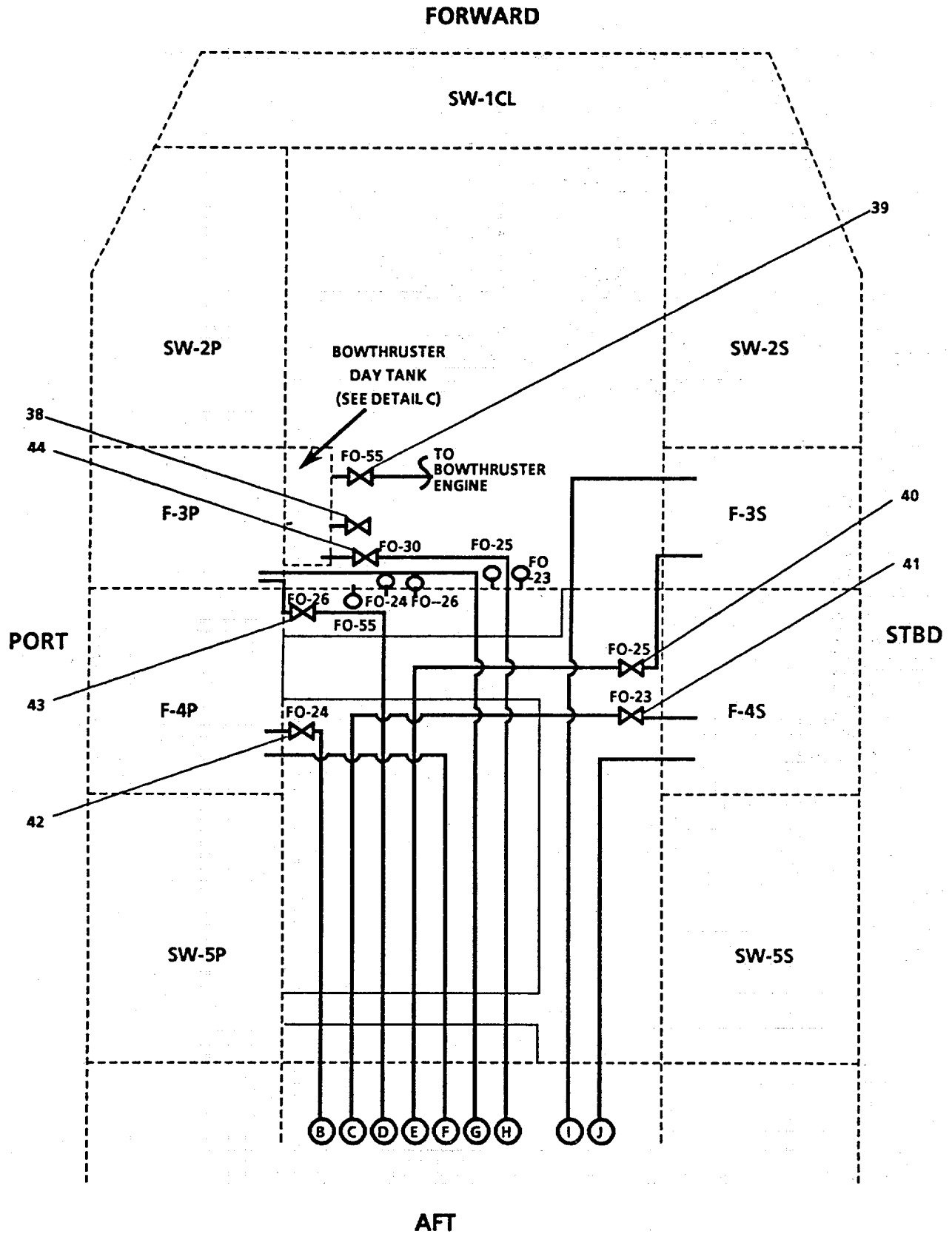

FIGURE 2-236. Fuel Oil Filter, Transfer, and Supply Piping System (Sheet 2 of 6)



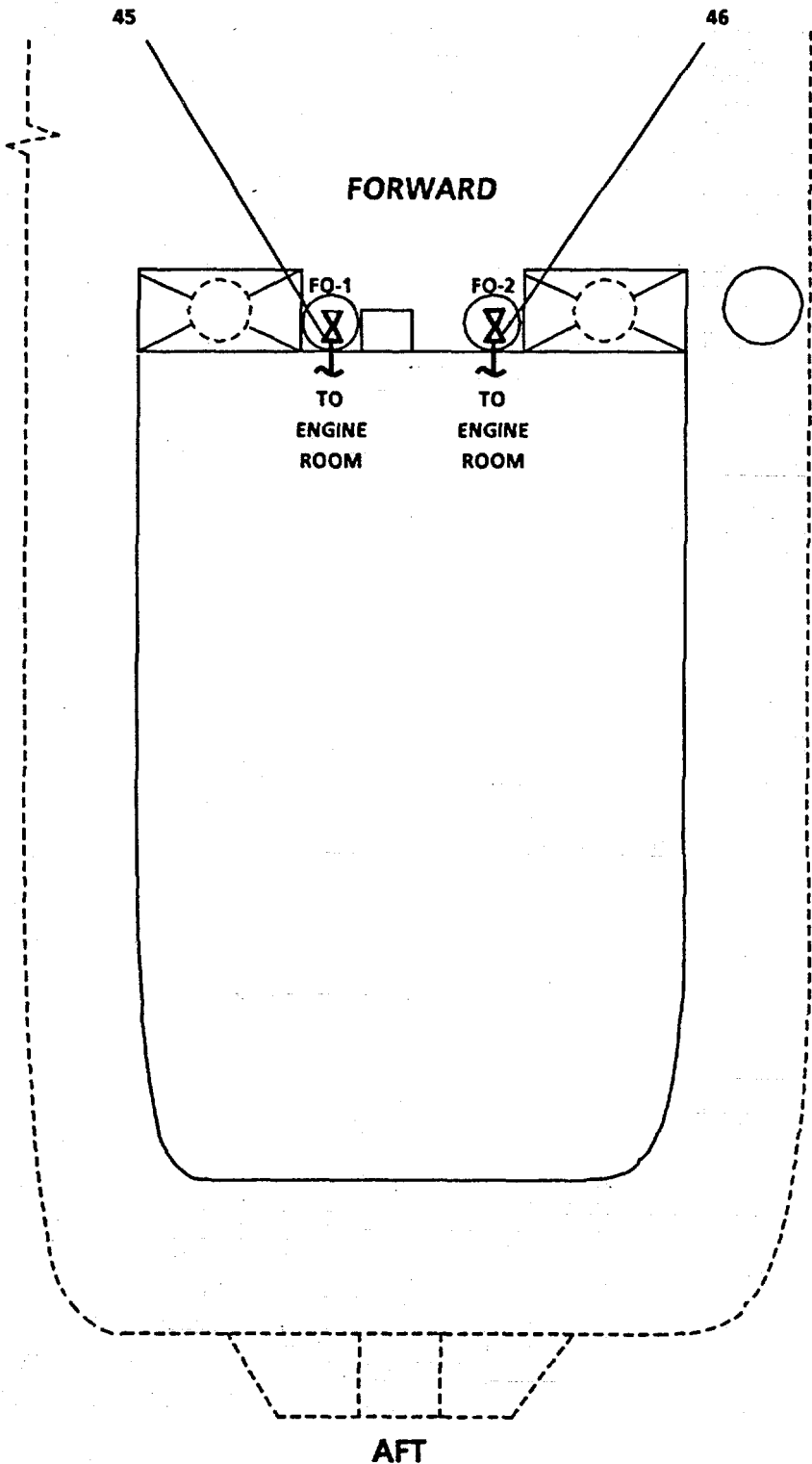
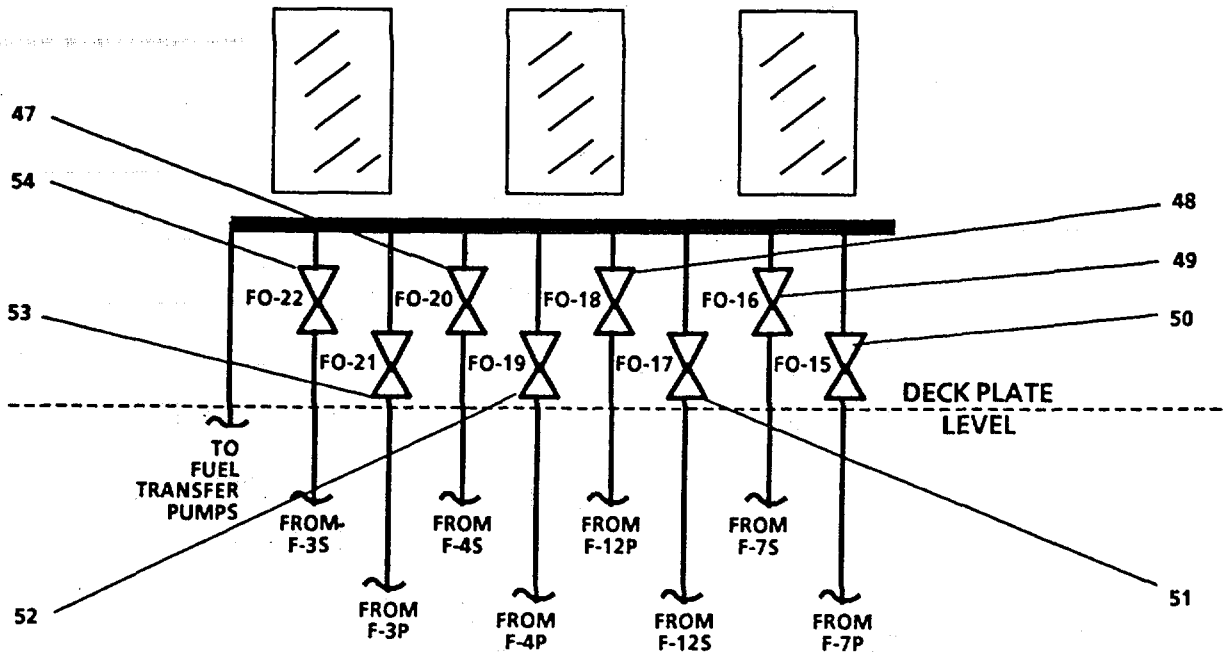

FIGURE 2-236. Fuel Oil Filter, Transfer, and Supply Piping System (Sheet 3 of 6).

**DETAIL A  
PORT EXTERIOR BULKHEAD  
OF EOS (FORWARD)**



**DETAIL B  
FORWARD EXTERIOR BULKHEAD  
OF EOS (PORT)**

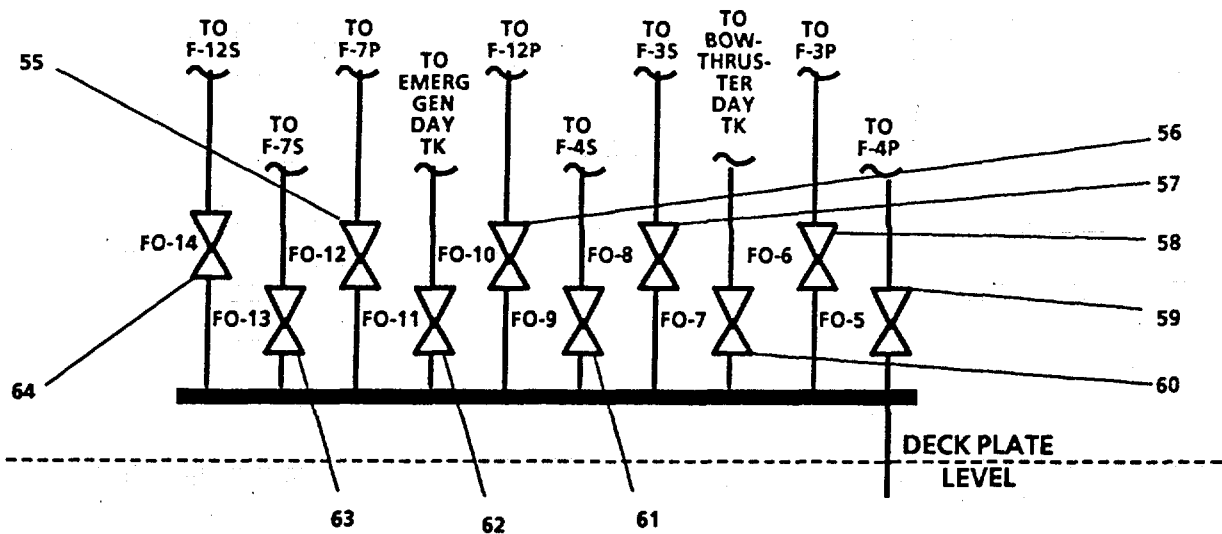

FIGURE 2-236. Fuel Oil Filter, Transfer, and Supply Piping System (Sheet 4 of 6)

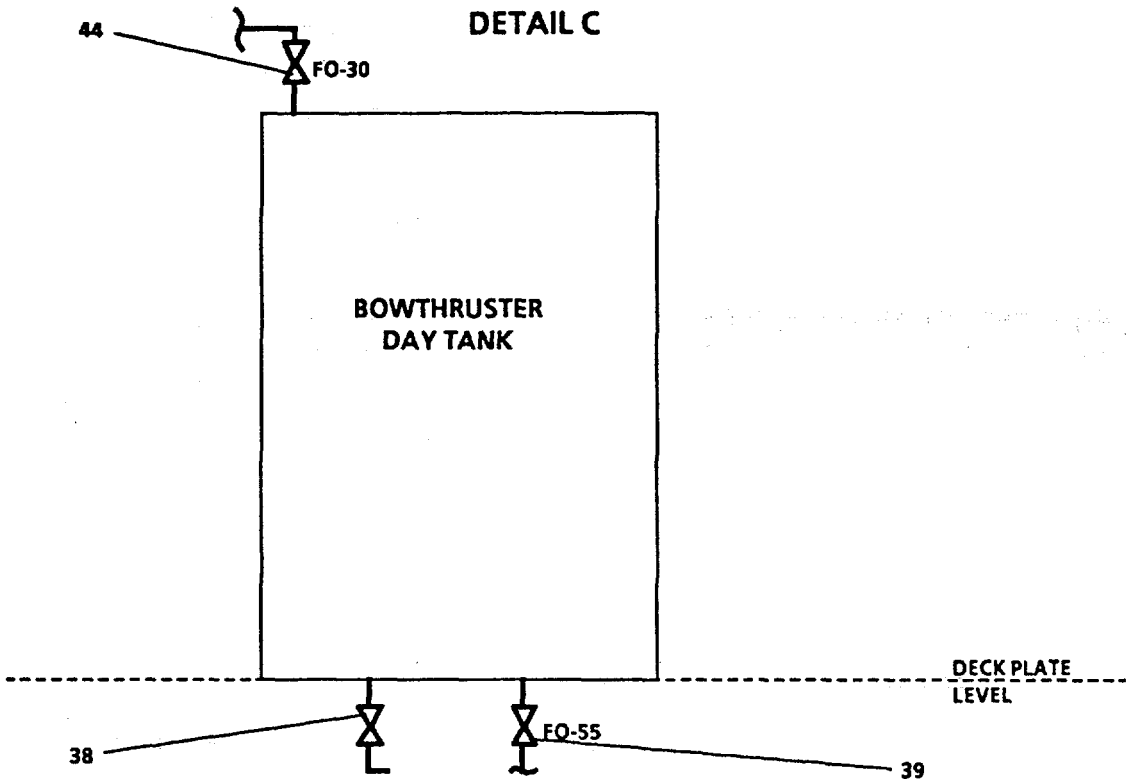
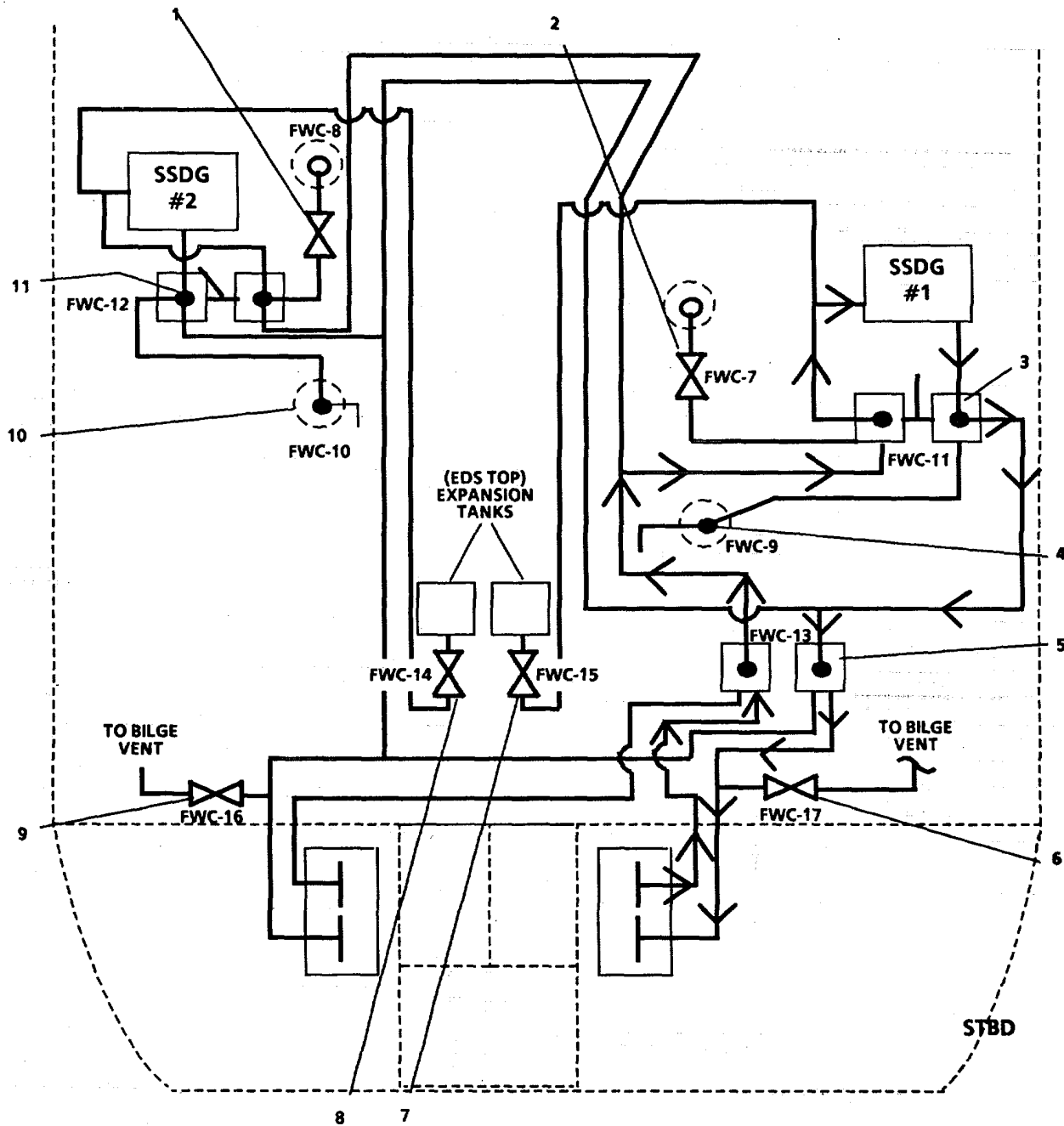

FIGURE 2-236. Fuel Oil Filter, Transfer, and Supply Piping System (Sheet 5 of 6).

**LEGEND**

- |  |  |
|--|--|
| <ol style="list-style-type: none"> <li>1. FO-3, ISLN-FILL/DISCH STATIONS</li> <li>2. FO-4, SUPPY TO FO SUPPLY MANF</li> <li>3. FO-44, DISCH -NO. 2 XFR PUMP</li> <li>4. FO-53, DISCH- NO. 1 XFR PUMP</li> <li>5. FO-52, SUCT-NO. 1 XFR PUMP</li> <li>6. FO-54, PUMP DISCH PRESS GAGE</li> <li>7. FO-51, FILTER/SEPARATOR OUTLET</li> <li>8. FO-49, PUMP SUCT PRESS GAGE</li> <li>9. FO-31, SUPPLY TO STBD SSDG</li> <li>10. SSDG FUEL FILTERS</li> <li>11. MN ENG FILTER DISCH VALVE</li> <li>12. MN ENG FILTER</li> <li>13. MN ENG FILTER INLET VALVE</li> <li>14. FO-37, RETURN FR STBD MN ENG TO DAY TK F-12S</li> <li>15. FO-39, RETURN FR STBD SSDG TO DAY TK F-12S</li> <li>16. FO-35, SUCT FR DAY TK F-12S</li> <li>17. FO-33, DAY TK F-12S SUPPLY TO STBD MN ENG &amp; SSDG</li> <li>18. FO-41, DRAIN FR DAY TK F-12S</li> <li>19. FO-27, SUCT FR TK F-7S</li> <li>20. FO-29, CROSS CONN - DAY TKS</li> <li>21. FO-28, SUCT FR TK F-7P</li> <li>22. FO-36, DAY TK F-12P SUPPLY TO PORT MN ENG &amp; SSDG</li> <li>23. FO-42, DRAIN FR DAY TK F-12P</li> <li>24. FO-34, SUCT FR DAY TK F-12P</li> <li>25. FO-38, RETURN FR PORT MN ENG TO DAY TK F-12P</li> <li>26. FO-40, RETURN FR PORT SSDG TO DAY TK F-12P</li> <li>27. FO-32, SUPPLY TO PORT SSDG</li> <li>28. FO-50, DRAIN TO SLUDGE TK</li> <li>29. FUEL FILTER/COALESCER</li> <li>30. FUEL TRANSFER HAND PUMP</li> <li>31. FO-47, FILTER/SEPARATOR INLET</li> <li>32. FO-45, HAND PUMP DISCH</li> </ol> | <ol style="list-style-type: none"> <li>33. FO-46, HAND PUMP SUCT</li> <li>34. FO-48, BY-PASS FILTER/SEPARATOR</li> <li>35. FO-43, SUCT-NO. 2 XFR PUMP</li> <li>36. NO. 2 XFR PUMP</li> <li>37. NO. 1 XFR PUMP</li> <li>38. BOW THRUSTER DAY TK DRAIN</li> <li>39. FO-55, SUPPLY TO BOW THRUSTER ENGINE</li> <li>40. FO-25, SUCT FR TK F-3S</li> <li>41. FO-23, SUCT FR TK F-4S</li> <li>42. FO-24, SUCT FR TK F-4P</li> <li>43. FO-26, SUCT FR TK F-3P</li> <li>44. FO-30, SUPPLY TO BOW THRUSTER DAY TK</li> <li>45. FO-1, FUEL OIL FILL/DISCH</li> <li>46. FO-2, FUEL OIL FILL/DISCH</li> <li>47. FO-20, SUCT FR TK F-4S</li> <li>48. FO-18, SUCT FR TK F-12P</li> <li>49. FO-16, SUCT FR TK F-7S</li> <li>50. FO-15, SUCT FR TK F-7P</li> <li>51. FO-17, SUCT FR TK F-12S</li> <li>52. FO-19, SUCT FR TK F-4P</li> <li>53. FO-21, SUCT FR TK F-3P</li> <li>54. FO-22, SUCT FR TK F-3S</li> <li>55. FO-12, SUPPLY TO TK F-7P</li> <li>56. FO-10, SUPPLY TO DAY TK F-12P</li> <li>57. FO-8, SUPPLY TO TK F-3S</li> <li>58. FO-6, SUPPLY TO TK F-3P</li> <li>59. FO-5, SUPPLY TO TK F-4P</li> <li>60. FO-7, SUPPLY TO TO BOW THRUSTER DAY TK</li> <li>61. FO-9, SUPPLY TO TK F-4S</li> <li>62. FO-11, SUPPY TO EMER GEN DAY TK</li> <li>63. FO-13, SUPPY TO TK F-7S</li> <li>64. FO-14, SUPPY TO TK F-12S</li> </ol> |
|--|--|

FIGURE 2-236. Fuel Oil Filter, Transfer, and Supply Piping System (Sheet 6 of 6).



**LEGEND**

- |   |  |
|---|--|
| 1. FWC-8, KEEL CLR OUTLET                           | 7. FWC-15, EXP TK-SSDG STBD                      |
| 2. FWC-7, KEEL CLR OUTLET                           | 8. FWC-14, EXP TK-SSDG PORT                      |
| 3. FWS-11, KEEL CLR/SSDG-STBD CLG MODE              | 9. FWC-16, VENT KEEL CLR IN SWP-8P               |
| 4. FWC-9, KEEL CLR INLET                            | 10. FWC-10, KEEL CLR INLET                       |
| 5. FWC-13, KEEL CLR SELECTOR BLST TK SW-8P OR SW-8S | 11. FWC-12, KEEL CLR/SSDG-PORT CLG MODE SELECTOR |
| 6. FWC-17, VENT KEEL CLR IN SW-8S                   |  |

FIGURE 2-237. SSDG Fresh Water Cooling Piping System (Sheet 1 of 2).

DETAIL A

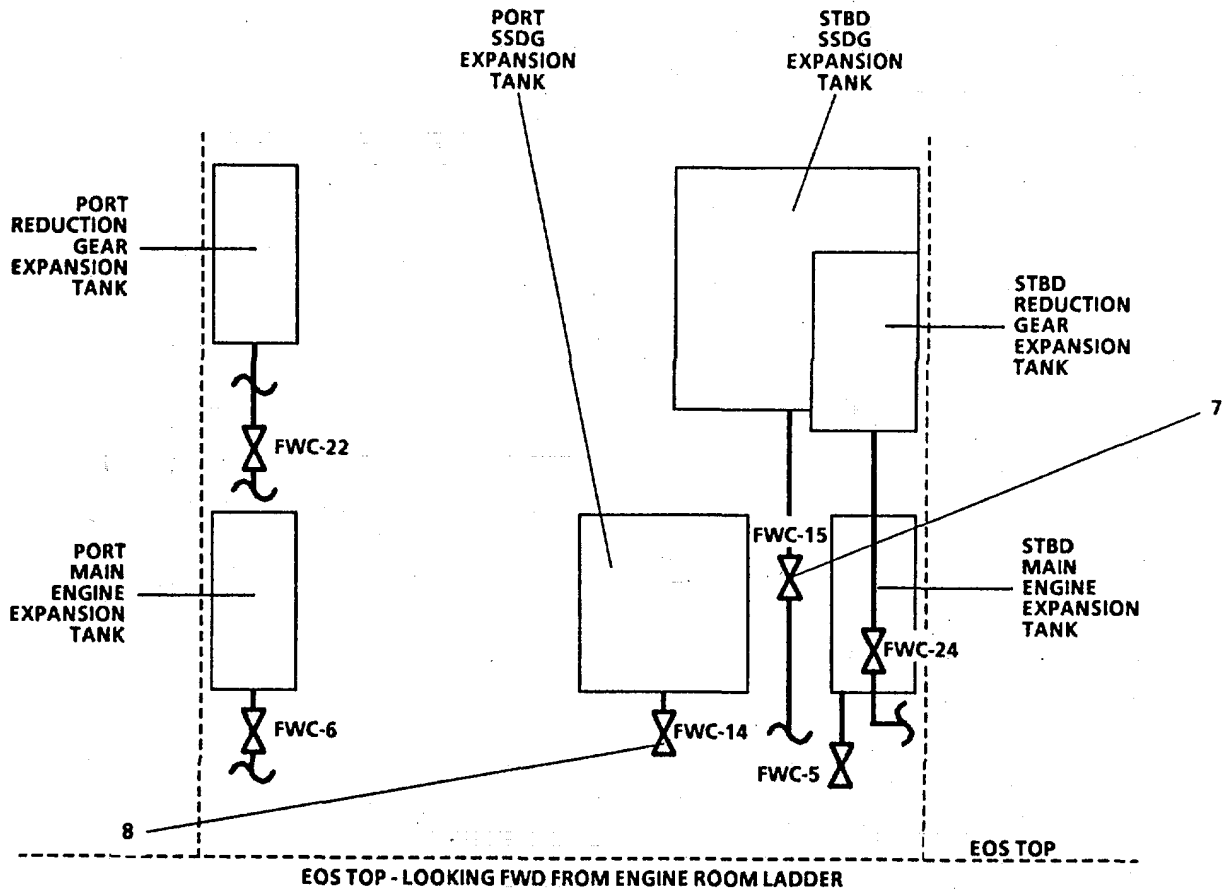

LEGEND:

- 7. FWC-15, EXP TK-SSDG STBD
- 9. FWC-14, EXP TK-SSDG PORT

FIGURE 2-237. SSDG Fresh Water Cooling Piping System (Sheet 2 of 2).

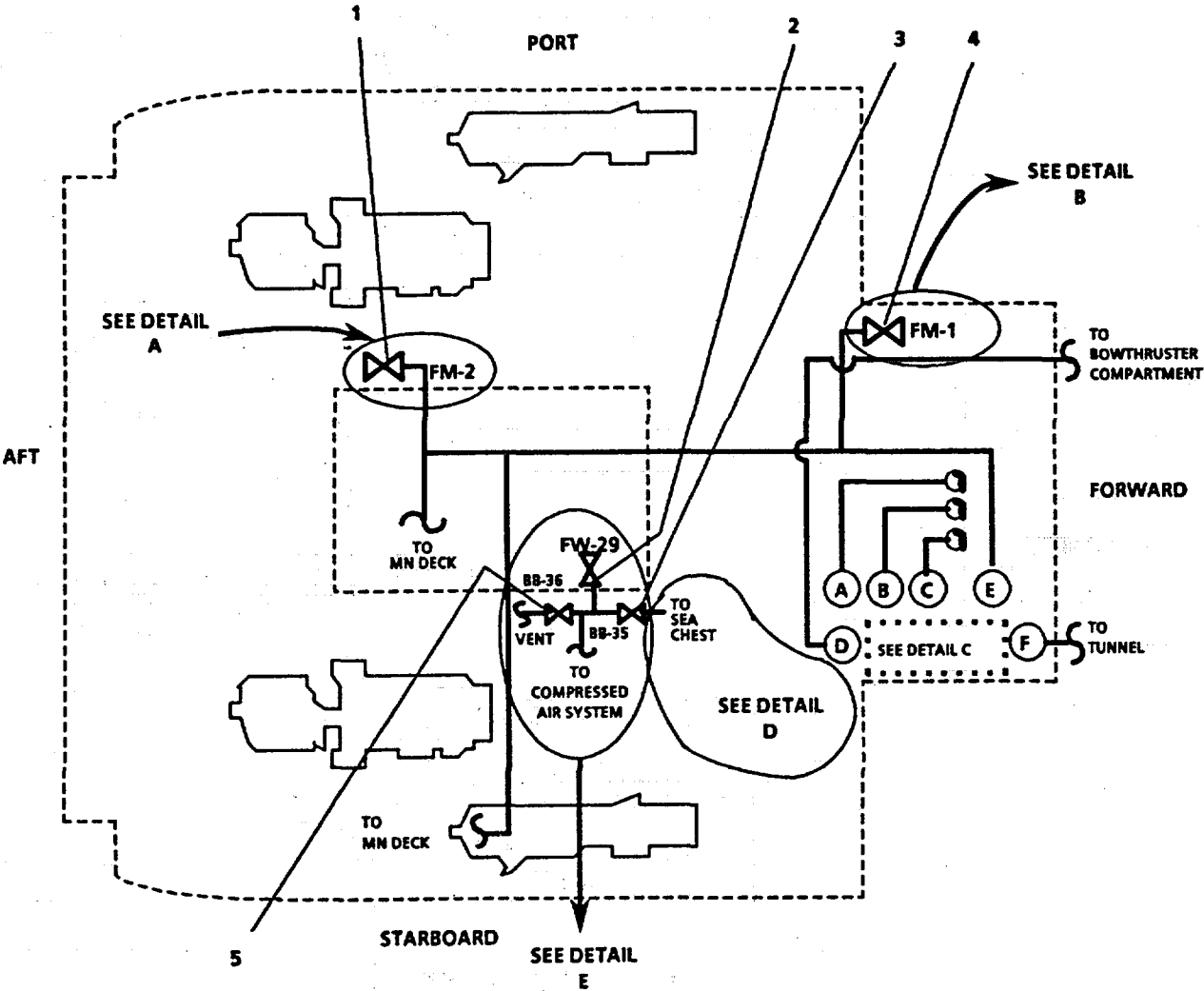

**ENGINE ROOM DRAWING**

FIGURE 2-238. Fire Main and Foam Piping System (Sheet 1 of 12).

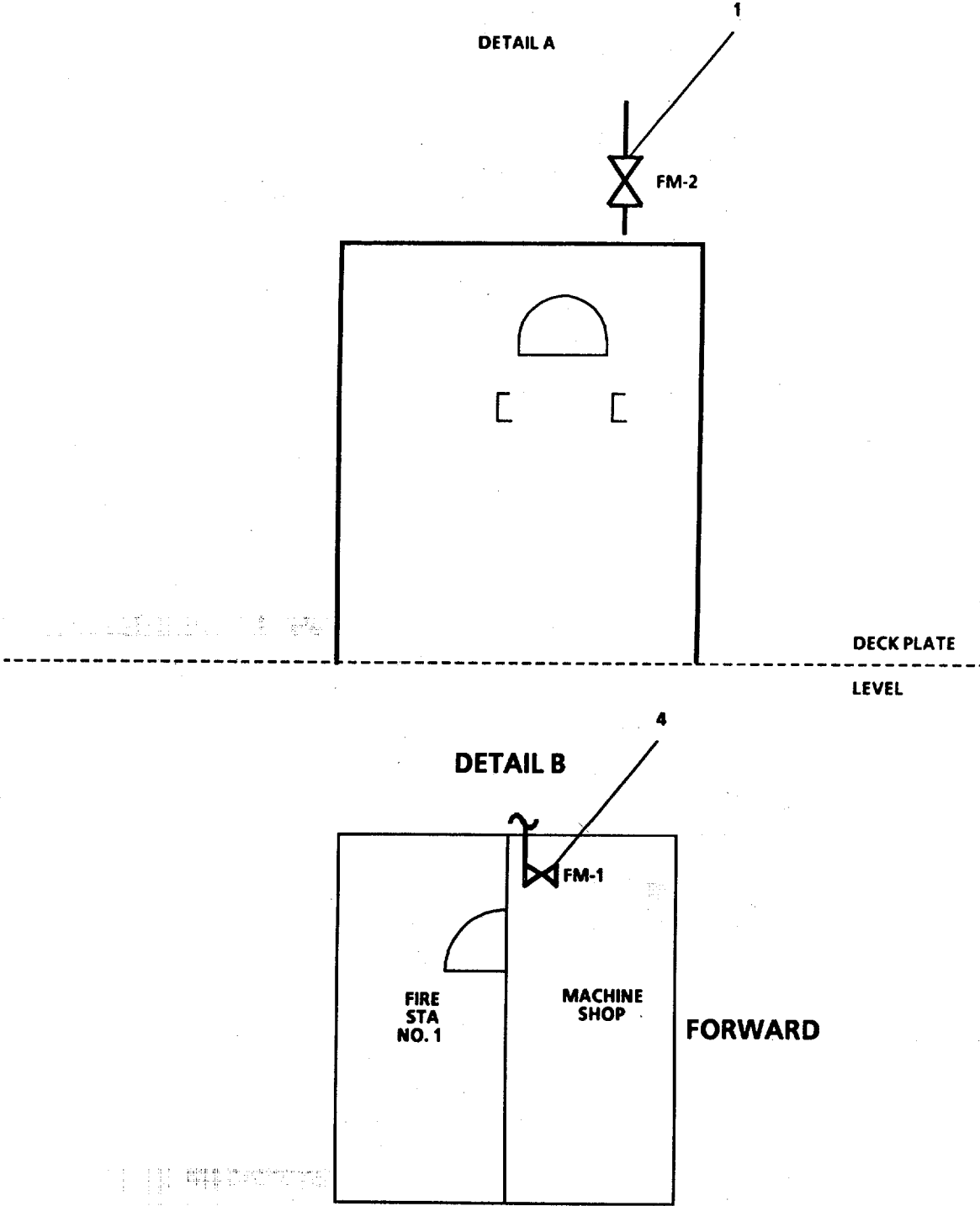
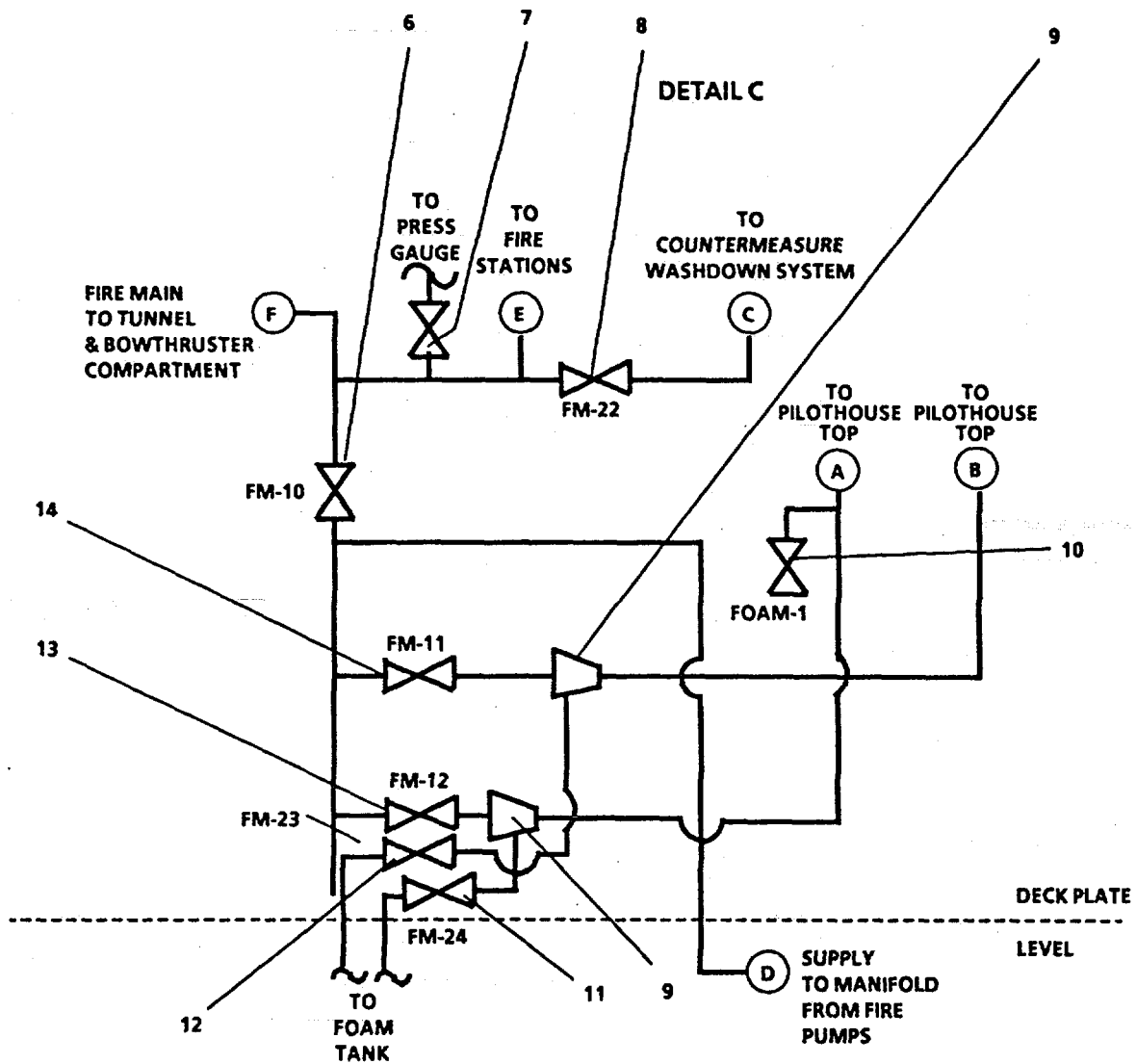

FIGURE 2-238. Fire Main and Foam Piping System (Sheet 2 of 12).





**LOOKING STARBOARD AT PORT BULKHEAD OF STOREROOM**

FIGURE 2-238. Fire Main and Foam Piping System (Sheet 3 of 12).

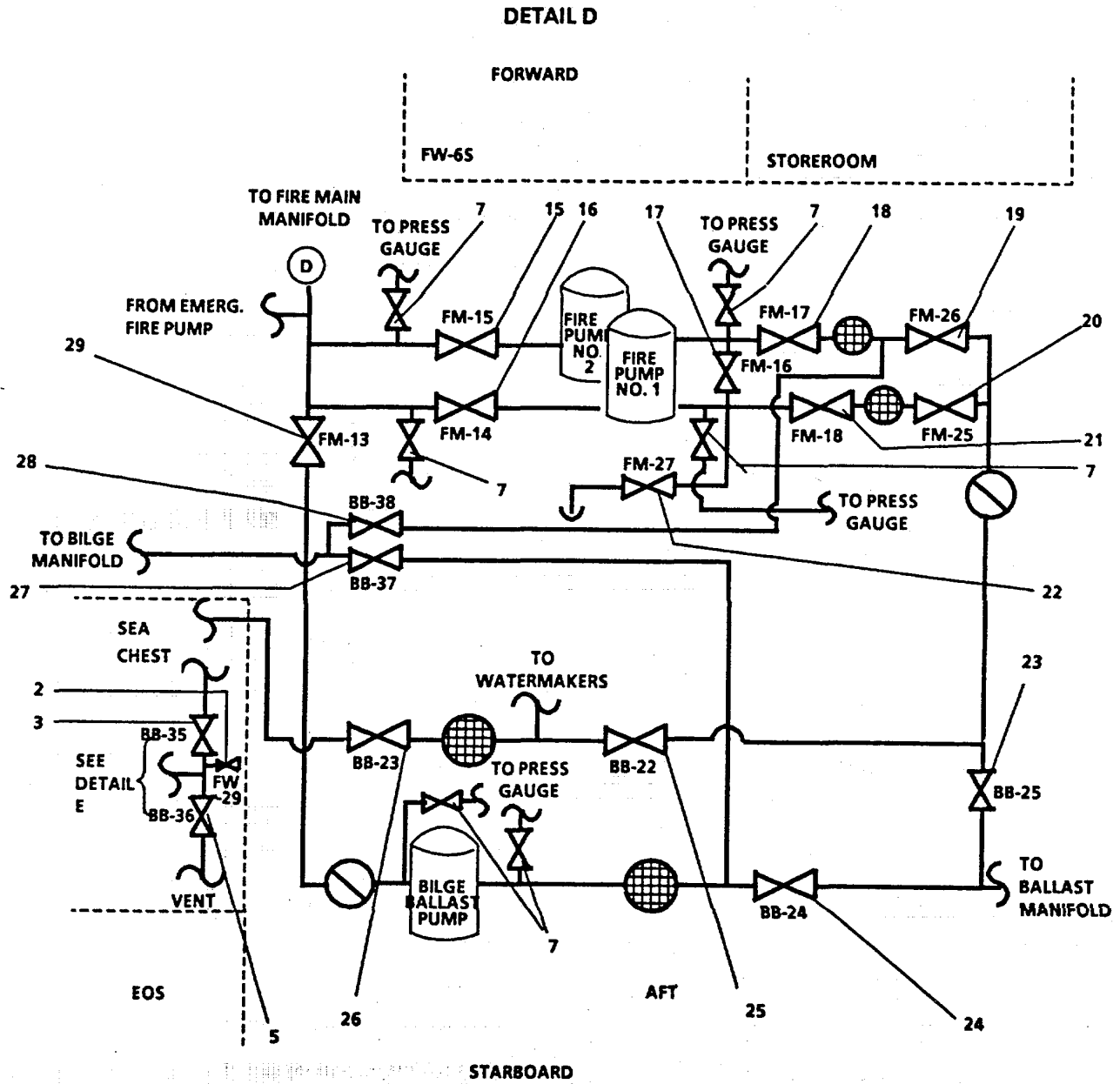

FIGURE 2-238. Fire Main and Foam Piping System (Sheet 4 of 12).

DETAIL E

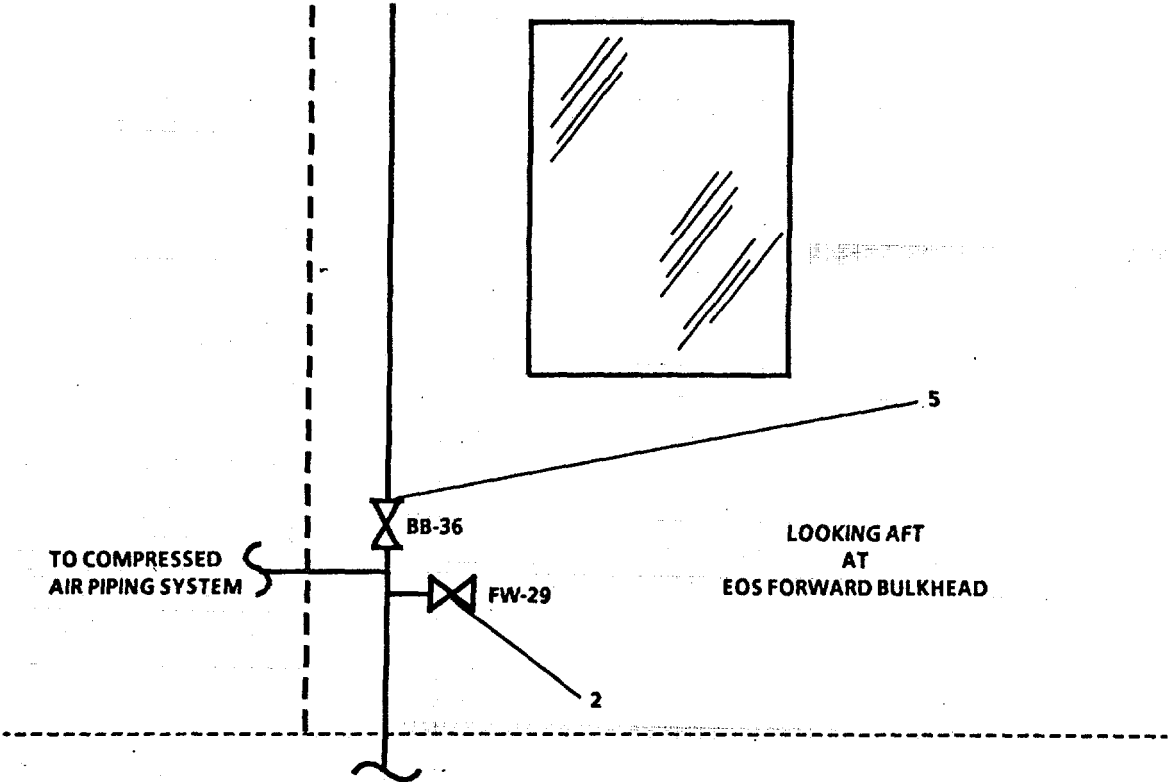

FIGURE 2-238. Fire Main and Foam Piping System (Sheet 5 of 12).

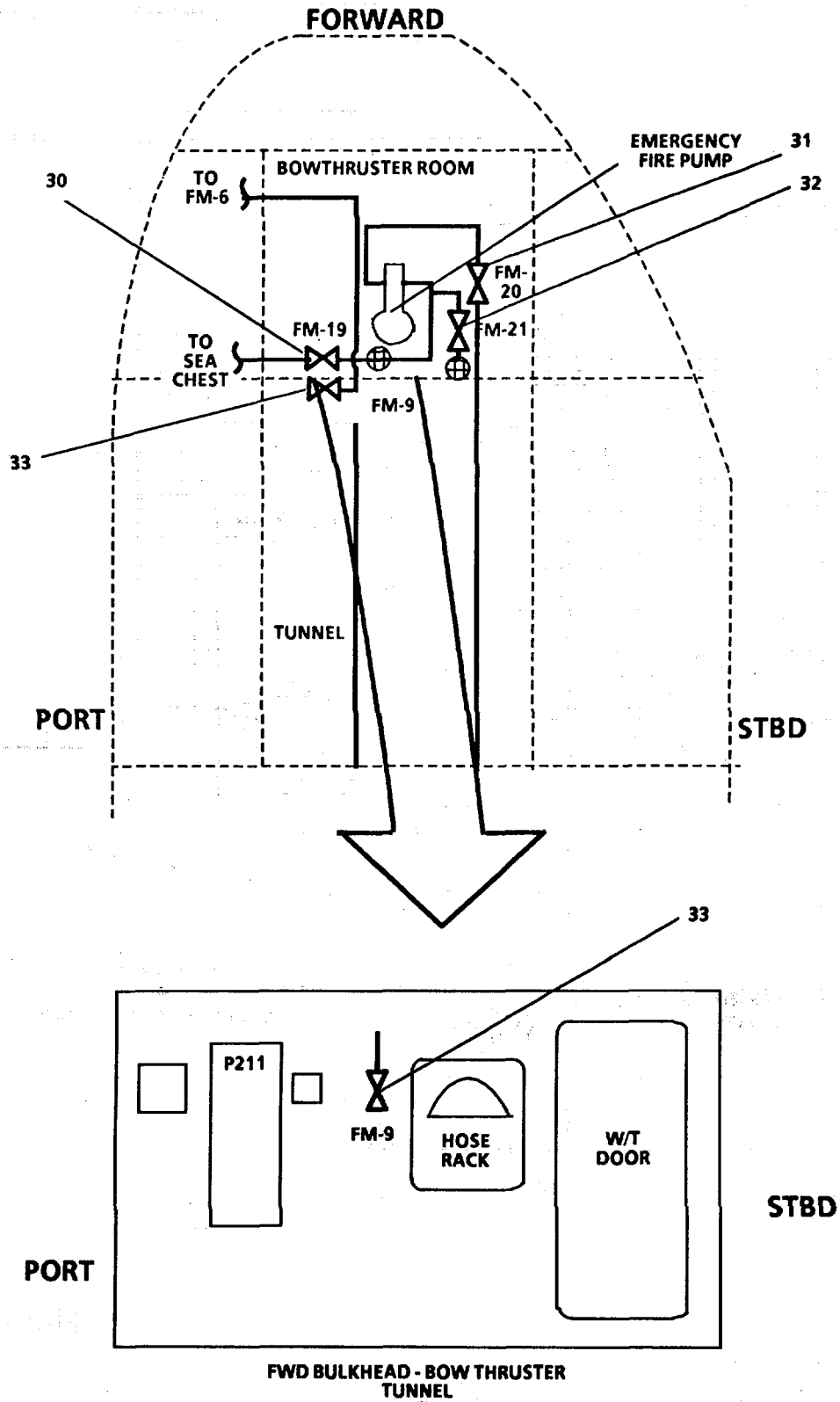

FIGURE 2-238. Fire Main and Foam Piping System (Sheet 6 of 12).

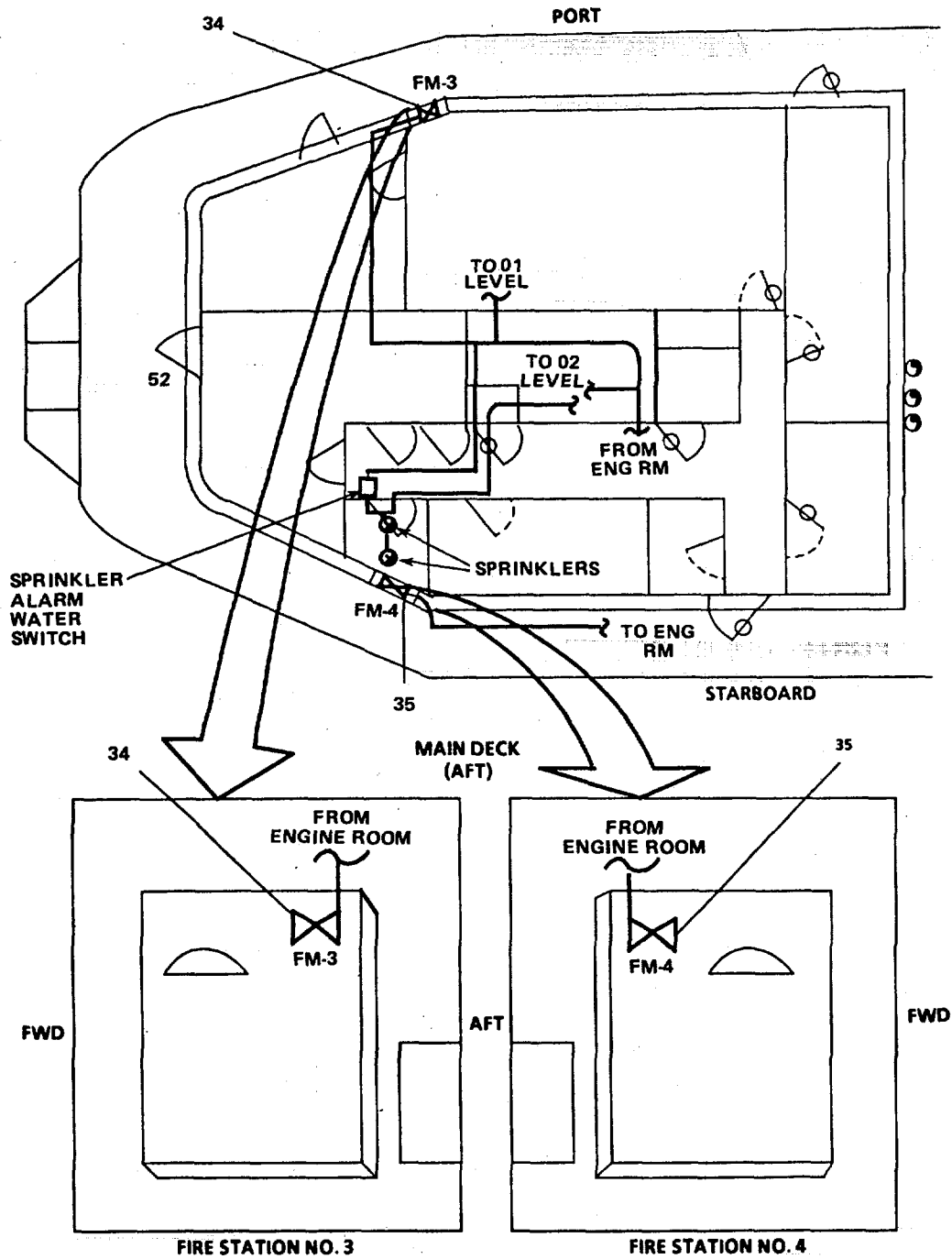

FIGURE 2-238. Fire and Main and Foam Piping System (Sheet 7 of 12).

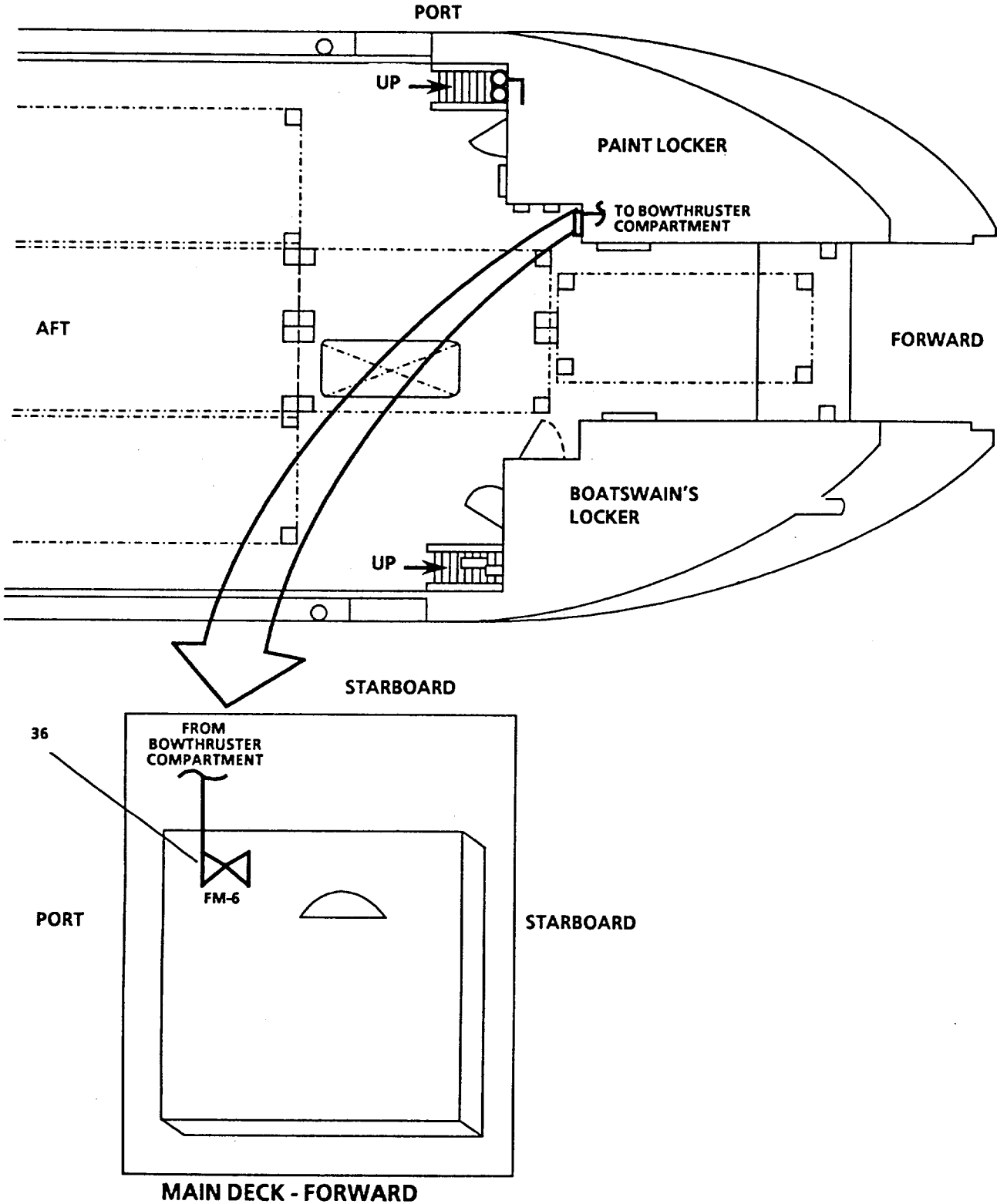

FIGURE 2-238. Fire Main and Foam Piping System (Sheet 8 of 12)

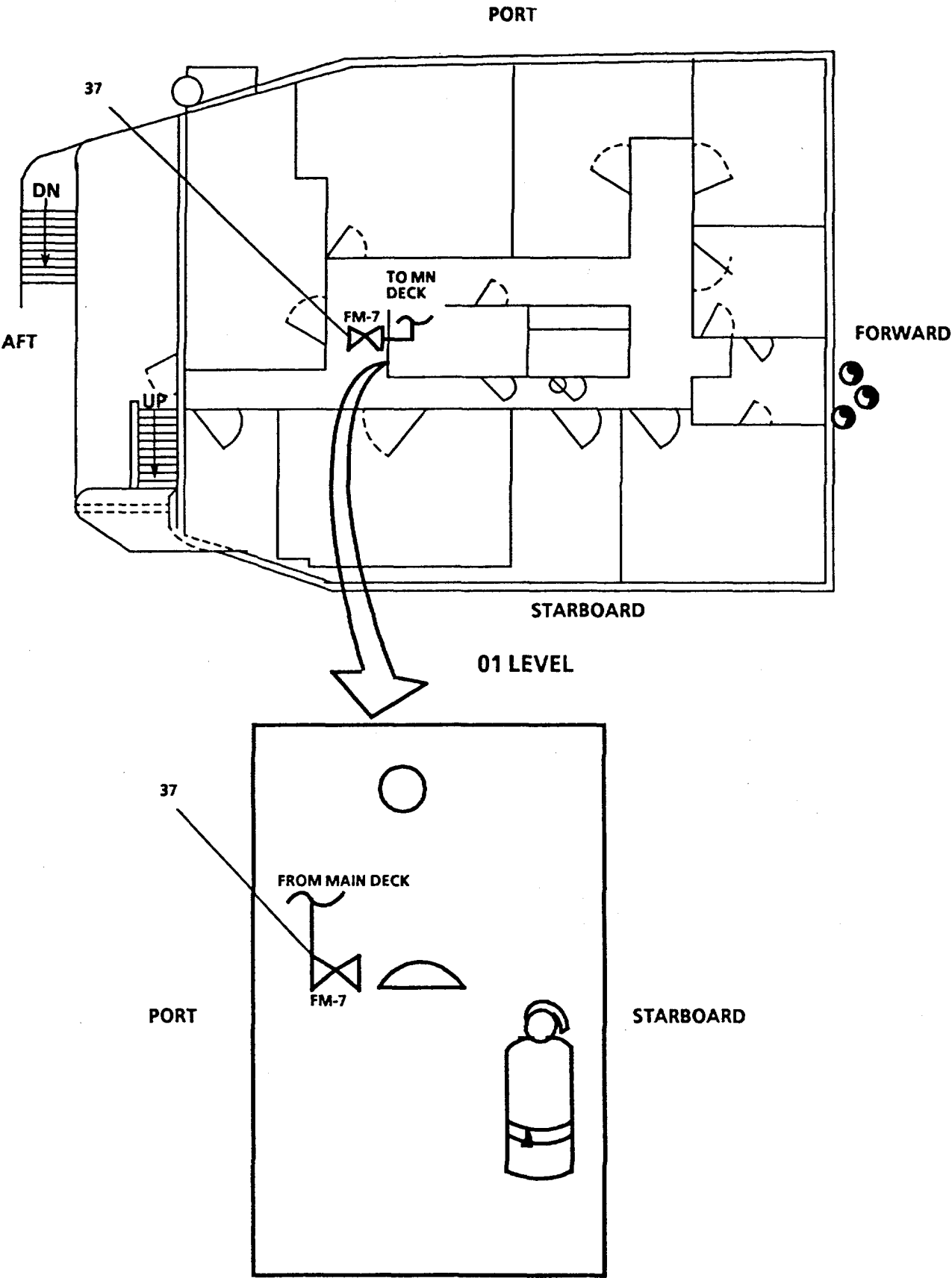

FIGURE 2-238. Fire Main and Foam Piping System (Sheet 9 of 12)

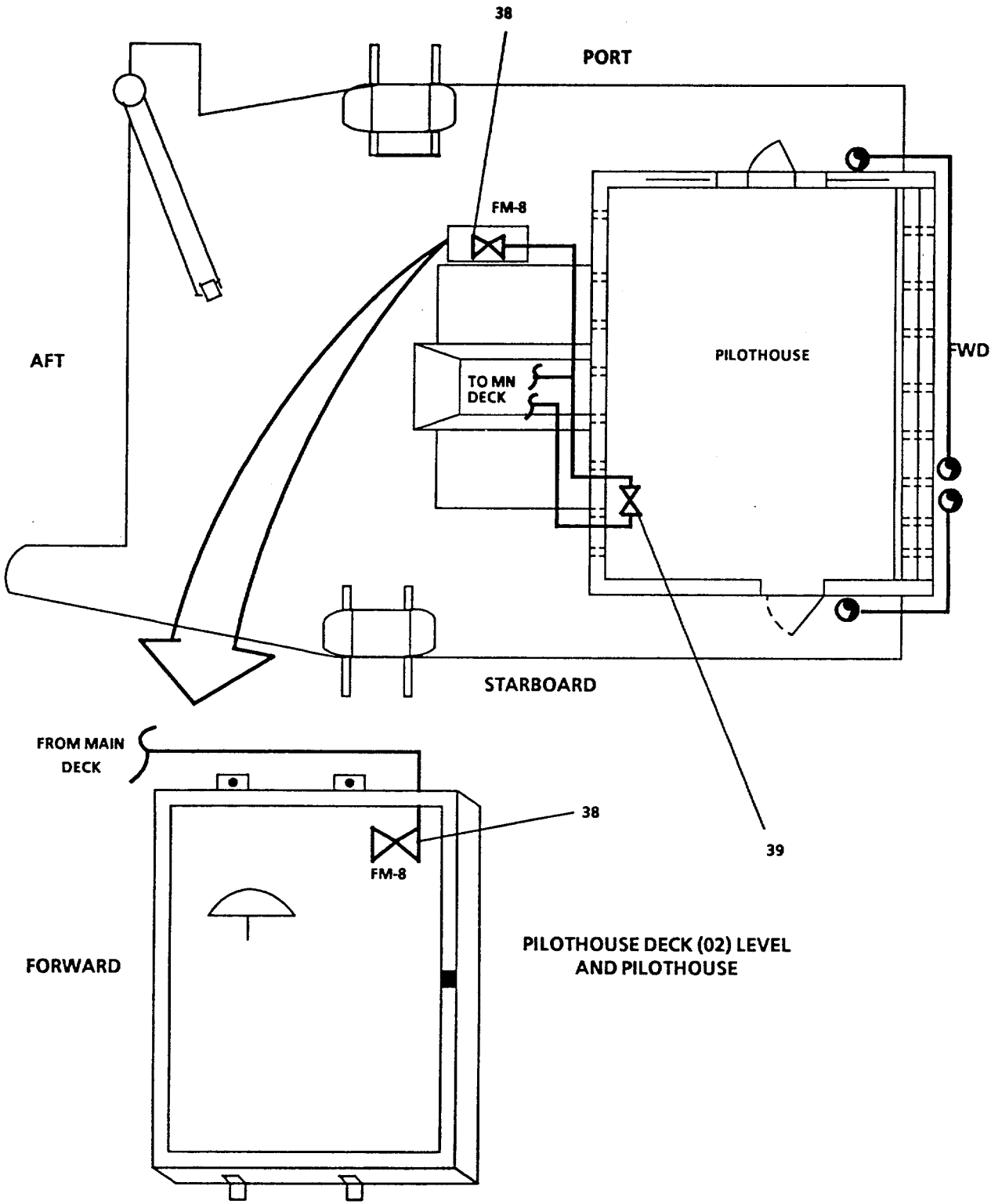

FIGURE 2-238. Fire Main and Foam Piping System (Sheet 10 of 12)



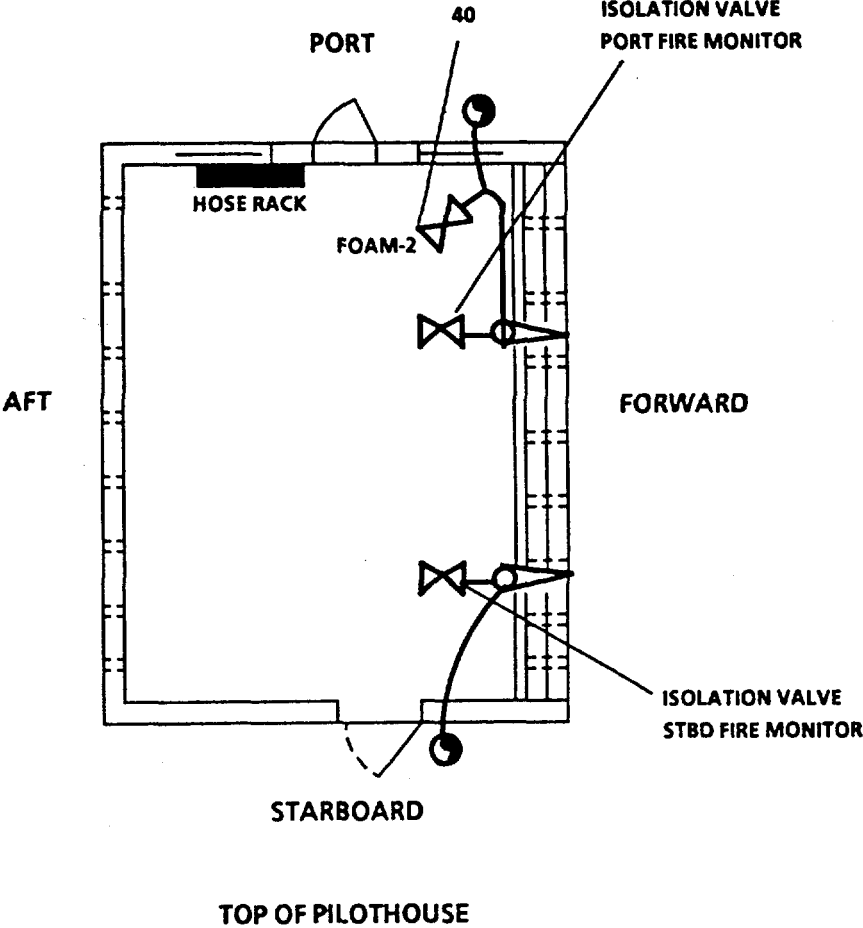

FIGURE 2-238. Fire Main and Foam Piping System (Sheet 11 of 12)

**LEGEND**

- |   |  |
|---|--|
| 1. FM-2, FIRE STA 2 ISLN                      | 21. FM-18, FIRE PUMP NO. 1 SUCT                        |
| 2. FW-29, SEA CHEST HOT FW CONN               | 22. FM-27, ENG RM EMERG BILGE SUCT                     |
| 3. BB-35, SEACHEST VENT ISOLATION             | 23. BB-25, ISLN-SEA CHEST                              |
| 4. FM-1, FIRE STA 1 ISLN                      | 24. BB-24, SUCT-BILGE/BALLAST PUMP                     |
| 5. BB-36, SEACHEST VENT                       | 25. BB-22, ISLN - SEA CHEST                            |
| 6. FM-10, FIREMAIN ISLN                       | 26. BB-23 SEA CHEST SUCT                               |
| 7. PRESSURE GAUGE ISOLATION                   | 27. BB-37, CROSS CONN TO BILGE MANIFOLD                |
| 8. FM-22, CM WASHDOWN ISLN                    | 28. BB-38, CROSS CONN FIRE PUMP SUCT TO BILGE MANIFOLD |
| 9. EDUCTOR                                    | 29. FM-13, FIREMAN & BALLAST CROSS CONN                |
| 10. FOAM-1, FOAM STA 1 ISLN                   | 30. FM-19, EMERG FIRE PUMP                             |
| 11. FM-24, PORT FOAM MONITOR ISLN             | 31. FM-20, EMERG FIRE PUMP DISCH                       |
| 12. FM-23, STBD FOAM MONITOR ISLN             | 32. FM-21, EMERG BILGE SUCT                            |
| 13. FM-12, FOAM STA 1 & STBD MONITOR ISLN     | 33. FM-9, FIRE STA 9 ISLN                              |
| 14. FM-11, FOAM STA 2 & PORT MONITOR ISLN     | 34. FM-3, FIRE STA 3 ISLN                              |
| 15. FM-15, NO. 2 FIRE PUMP DISCH              | 35. FM-4, FIRE STA 4 ISLN                              |
| 16. FM-14, NO. 1 FIRE PUMP DISCH              | 36. FM-6, FIRE STA 6 ISLN                              |
| 17. FM-16, FIRE PUMP 1&2 SUCT CROSS CONN      | 37. FM-7, FIRE STA 7 ISLN                              |
| 18. FM-17, FIRE PUMP NO. 2 SUCT               | 38. FM-8, FIRE STA 8 ISLN                              |
| 19. FM-26, NO. 2 FIRE PUMP STRAINER ISOLATION | 39. ARMS ROOM SPRINKLER MANUAL ACTIVATION VALVE        |
| 20. FM-25, NO. 1 FIRE PUMP STRAINER ISOLATION | 40. FOAM-2, FOAM STA 2 ISLN                            |

FIGURE 2-238. Fire Main and Foam Piping System (Sheet 12 of 12).

- c. On Fire Pump Motor Switch (FIGURE 2-239), press STOP (2) and slide LOCK (3) upwards to lock-in STOP pushbutton (2) for both fire pumps.
- d. Close FM-11, FOAM STA 2 and PORT MONITOR ISLN (14, FIGURE 2-238).
- e. Close FM-12, FOAM STA 1 and STBD MONITOR ISLN (13).
- f. Close FM-10, FIREMAIN ISLN (6).
- g. Close FM-15, NO. 2 FIRE PUMP DISCH (15).
- h. Close FM-14, NO. 1 FIRE PUMP DISCH (16).
- i. Close FM-17, FIRE PUMP NO. 2 SUCT (18).
- j. Close FM-18, FM-18, FIRE PUMP NO. 1 SUCT (21).
- k. Close FM-26, NO. 2 FIRE PUMP STRAINER ISOLATION (19).
- l. Close FM-25, NO. 1 FIRE PUMP STRAINER ISOLATION (20).

**CAUTION**

Before proceeding, ensure the BILGE/BALLAST PUMP and Watermaker have been shutdown or damage to this equipment could result.

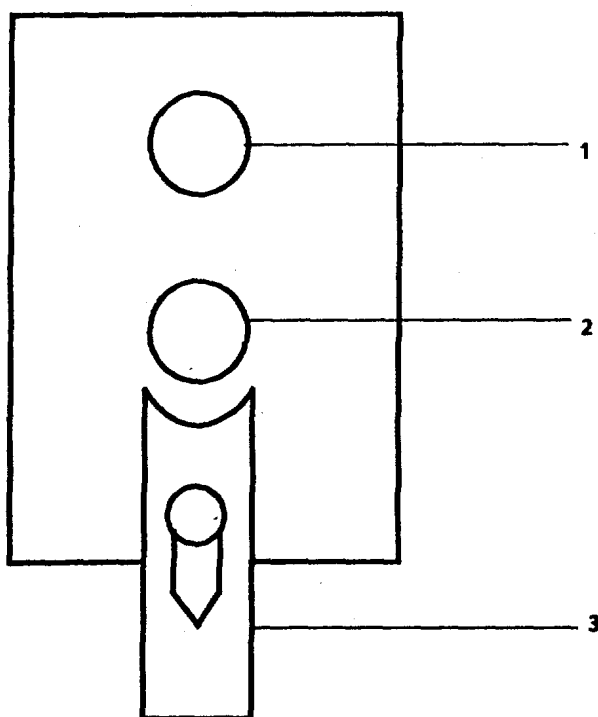

- LEGEND**
- 1. START
  - 2. STOP
  - 3. LOCK

FIGURE 2-239. Fire Pump Motor Switch.

- m. Close BB-22, ISLN-SEACHEST (25).
- n. Close BB-23, SEACHEST SUCT (26).
- o. Close BB-35 Seachest Vent Isolation (3).
- p. Close BB-36 Seachest Vent Valve (5).

**2-44. Final Shutdown.**

- a. On Machinery Plant Monitor Panel (FIGURE 2-240), set power switch (1) to OFF position.
- b. On Engine Efficiency Panel (FIGURE 2-241), set FIELD switch (2) to OFF position.
- c. Set MAIN switch (1) to OFF position.
- d. Ensure all circuit breakers on all power panels, motor controllers, motor control centers, and switchboards are in the OFF position.

**2-45. Rigging LCU to TOW.**

NOTE

The method used to tow another vessel in an emergency situation is determined by type of water, weather conditions, type of vessel to be towed, reason vessel requires tow, and equipment on hand suitable for rigging tows.

- a. Towing in Open Water (FIGURE 2-242).

NOTE

Towing in open water (ocean) should be restricted to extreme emergencies where action is required to avert severe damage to vessel needing assistance or injury to its crew.

- (1) Flake down a tow hawser on the port and starboard, stern, main deck.
- (2) Pass eye of each TOW HAWSER (4), through each CLOSED CHOCK (5) on the stern.

NOTE

Tow hawsers must pass outboard of all structures, protrusions, etc.

- (3) Use SHACKLE (2) to connect eye of each TOW HAWSER (4) to FISH1PLATE (1). Tack weld or mouse the shackle pin.
- (4) WHIP (3) eyes tight against the shackle.

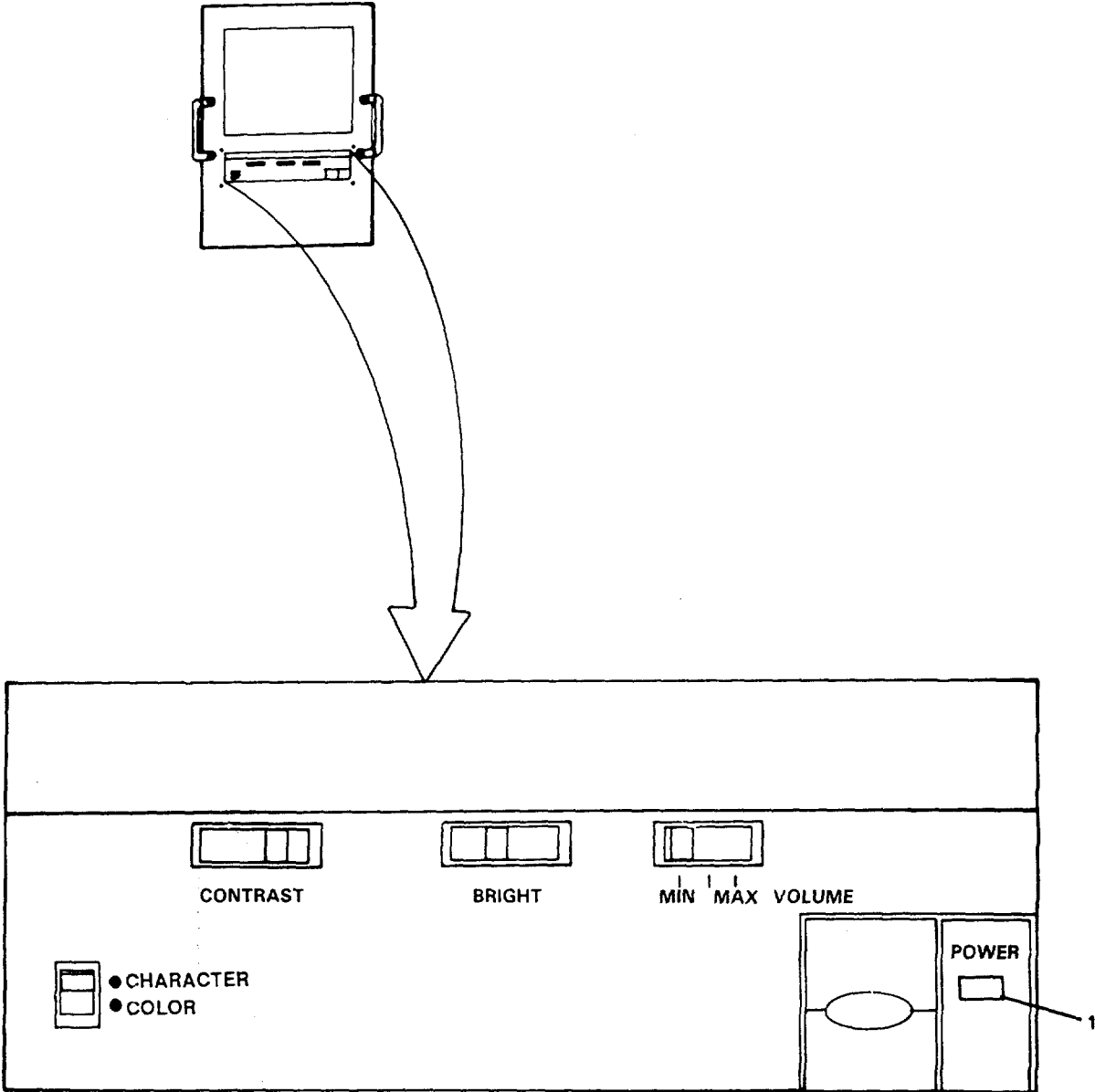

LEGEND  
1. POWER SWITCH

FIGURE 2-240. Machinery Plant Monitor Panel.

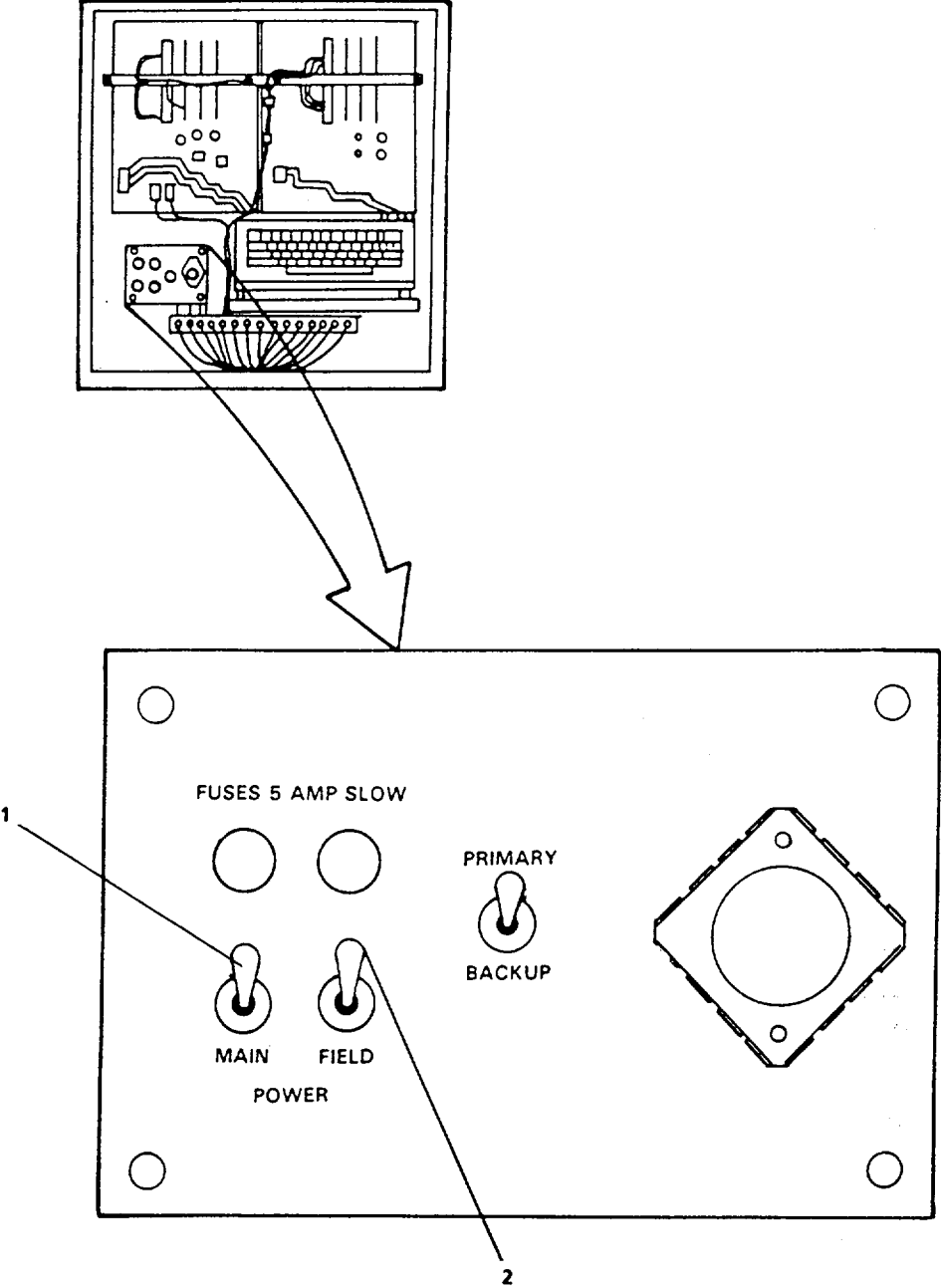

- LEGEND**
- 1. MAIN POWER SWITCH
  - 2. FIELD POWER SWITCH

FIGURE 2-241. Engine Efficiency Panel.

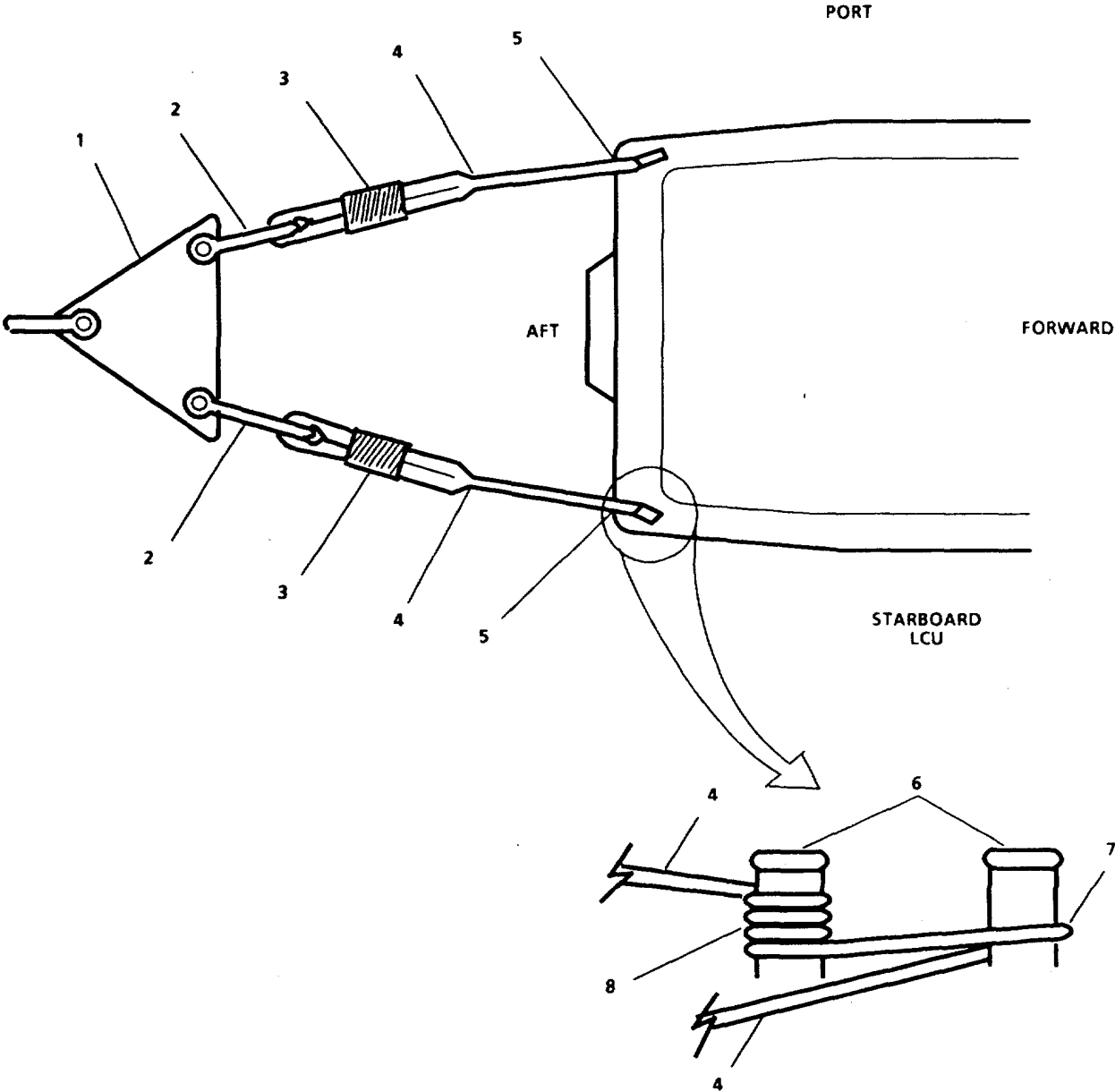

- LEGEND**
- |               |                 |
|---------------|-----------------|
| 1. FISHPLATE  | 5. CLOSED CHOCK |
| 2. SHACKLE    | 6. BITTS        |
| 3. WHIP       | 7. FULL TURN    |
| 4. TOW HAWSER | 8. THREE TURNS  |

FIGURE 2-242. LCU Rigged for Towing.

NOTE

Method used to pass tow gear to vehicle being towed will depend on how close LCU can maneuver.

- (5) Tie the bitter end of the service line of the shoulder fired line throwing appliance to a messenger line.
- (6) Tie the messenger line to the shackle (2) of the tow end of the fishplate (1).

NOTE

LCU must be within range of the tow considering local conditions before propelling the service projectile.

- (7) Fire service projectile across bow of tow.
- (8) Take two hawsers to bitts (6) and take a full turn and cross the two hawsers back onto itself (7). Take two or three turns (8) on the bitt (6) and standby to veer the tow hawser when the tow starts hauling in the messenger line.
- (9) Veer tow hawsers as tow hauls in.
- (10) Make tow hawsers fast while the tow is connecting their anchor chain to the fishplate (1) as tow hauls in.
- (11) When connection is complete, to include tack welding or mousing the shackle pin, have the tow pay out their anchor chain to desired length and set brake.

**WARNING**

- While veering the tow hawser to the desired length LCU engines must be operated ahead slow to avoid injury to personnel.
- Line handlers must keep hands well back from the bitts when veering the tow hawser.

**CAUTION**

Tow hawsers must be adjusted correctly to prevent parting the towing gear.

NOTE

The carenary must be adjusted when weather conditions, water depth or LCU speed change.



NOTE

It may be necessary for the tow to adjust the length of its anchor chain to achieve the desired catenary.

(12) Veer the tow hawsers (4) until the tow is astern the desired distance and the proper catenary is achieved. Tow hawsers must be adjusted until there is sufficient catenary in the tow line to prevent parting the towing gear.

(13) Secure the tow hawsers by figure eighting on the bitts (6).

NOTE

- Chafing gear may be made from canvas, split hose, or other such material.
- Chafing gear must extend at least twelve inches on each side of the point of contact to allow for stretch for the tow hawser.

(14) Apply chafing gear to each tow hawser at each point it makes contact.

b. Towing in protected water. The method used to tow in protected waters will use the same rigging as described in a. above. Adjust length of tow hawsers based upon the situation (e.g., weather conditions, type of vessel to be towed, reason vessel required tow, and equipment on hand).

**SECTION IV. OPERATION UNDER UNUSUAL CONDITIONS**

<u>Para.</u>		<u>Page</u>
2-46	General .....	2-641
2-47	Power Generation .....	2-641
2-48	Gyro Compass .....	2-642
2-49	Steering System Failure .....	2-648
2-50	Halon 1301 Fire Suppression System .....	2-651
2-51	Deballasting Using Fire Pumps .....	2-654
2-52	Bow Ramp .....	2-663
2-53	Main Engine Cold Weather Starting .....	2-669
2-54	Rigging the LCU To Be Towed .....	2-682
2-55	Firefighting System Operation .....	2-685
2-56	Launch and Retrieve Workboat In Heavy Weather .....	2-704
2-57	Launch Liferrafts .....	2-707
2-58	Nuclear, Biological and Chemical (NBC) Decontamination Procedures .....	2-707
2-59	Heavy Weather Preparations .....	2-709
2-60	Transfer of Fuel Using Hand Pump .....	2-710
2-61	Shore Power Connections .....	2-717
2-62	Emergency Control for AHEAD Only .....	2-720
2-63	FM-200 Fire Suppressant System .....	2-721
2-64	Water Washdown System (WWS) .....	2-741

**2-46. General.** This section contains operating procedures for individual equipment during periods of equipment failure and periods of unusual weather conditions.

**2-47. Power Generation.** Normal power from ship service generator, through the main switchboard, keeps the main and emergency switchboard bus tie circuit breakers closed. This voltage is also applied to the emergency switchboard emergency generator circuit breaker, to prevent it being closed. In the event of ship service power failure, the main switchboard and emergency switchboard bus tie circuit breakers will open. Simultaneously, several actions take place: (1) A mechanical dead bus timer will start, energizing the autocrank circuit of the emergency generator; (2) Batteries will provide power to emergency communications and lighting circuits; (3) The dead bus timer starts a 45-second time delay allowing the emergency generator on the emergency switchboard. These actions do not require operator intervention.

a. Emergency Equipment Available. When the emergency generator is supplying power to the emergency switchboard, the following equipment is operable:

- (1) Emergency generator jacket water heater
- (2) Fuel oil transfer pump number 2
- (3) Starboard steering gear system
- (4) Radio communication system
- (5) Wheelhouse lighting system
- (6) Wheelhouse intercommunications/lighting panel
- (7) Emergency lighting below main deck
- (8) Battery chargers

- (9) Wheelhouse DC electrical panel.
- (10) Fire detection system.
- (11) General alarm system.

b. Operate Main Switchboard on Emergency Power.

- (1) With emergency power ON, set all circuit breakers to OFF on Main Switchboard (FIGURE 2-243).
- (2) At emergency switchboard, set BYPASS switch (1, FIGURE 2-244) to BYPASS position.
- (3) Select required equipment needed and set required circuit breaker to ON position.

**CAUTION**

**Emergency power is only 40kw compared to 250 kw normal power. Care must be taken not to overload the Emergency Generator.**

c. Reset Emergency Generator. When ship service diesel generators are operating, perform the following procedures:

- (1) Disconnect the load from the emergency generator set by pressing TRIP pushbutton (2, FIGURE 2-244).
- (2) Turn BYPASS switch (1) to NORM position.
- (3) Allow the generator set to run at no load for 5 minutes to cool down.
- (4) Following the 5 minute cool down period, move the RUN-OFF-AUTO (1, FIGURE 2-245) to the OFF position.
- (5) After shutdown, set MODE SWITCH (3, FIGURE 2-244) to AUTO position.

**2-48. Gyro Compass.**

a. Heavy Sea Starting.

- (1) Position RPTR switch (6, FIGURE 2-246) to OFF (down) and SELECTOR switch (4) to SLEW.

**NOTE**

**The compass will slew rapidly if the gyro is caged.**

- (2) Note that the CAGED lamp (9) is lighted. If it is not, depress the CAGED BUTTON (1), located on top of the binnacle, to cage the gyro and wait 5 minutes for the ballistic fluid to stabilize.
- (3) Use the TILT/AZIMUTH switch (5) to rotate the compass card to the approximate course of the ship. In the (+) position, the card rotates counterclockwise; in the (-) position, the card rotates clockwise.

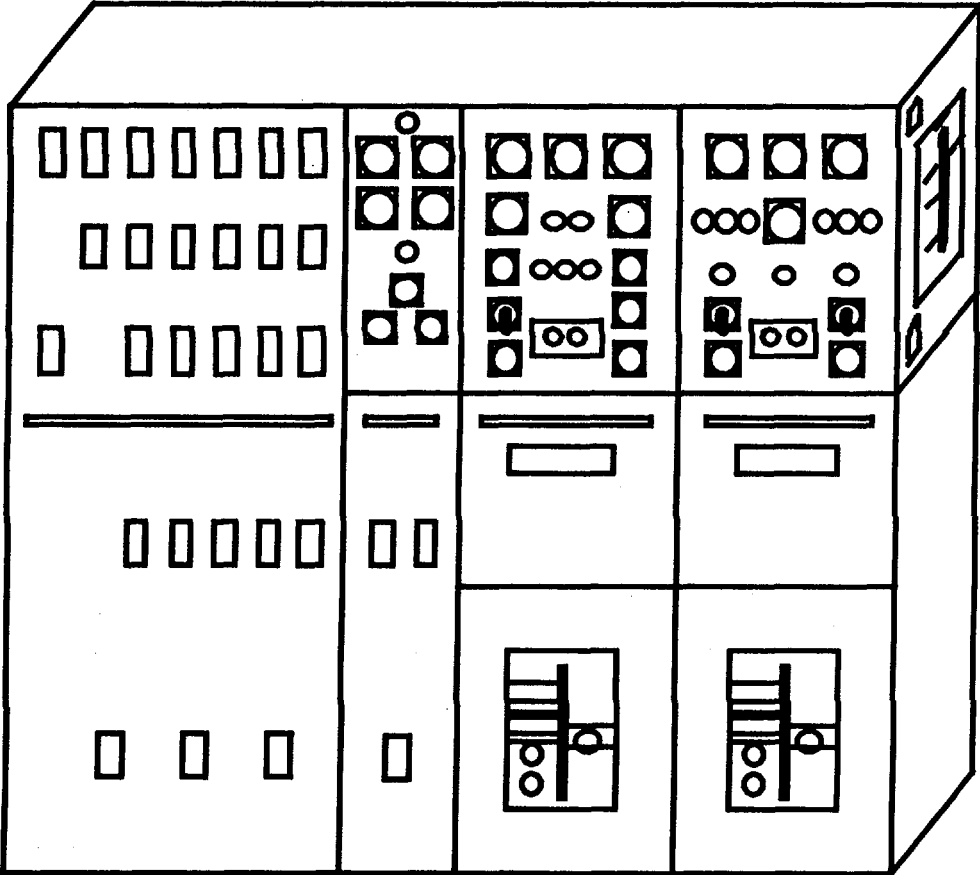
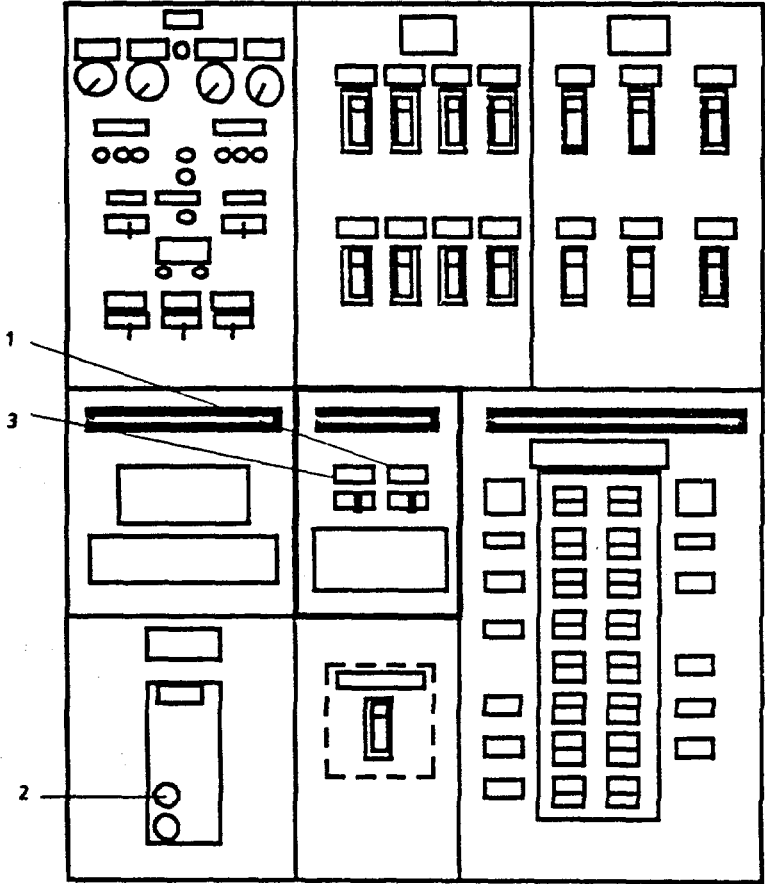
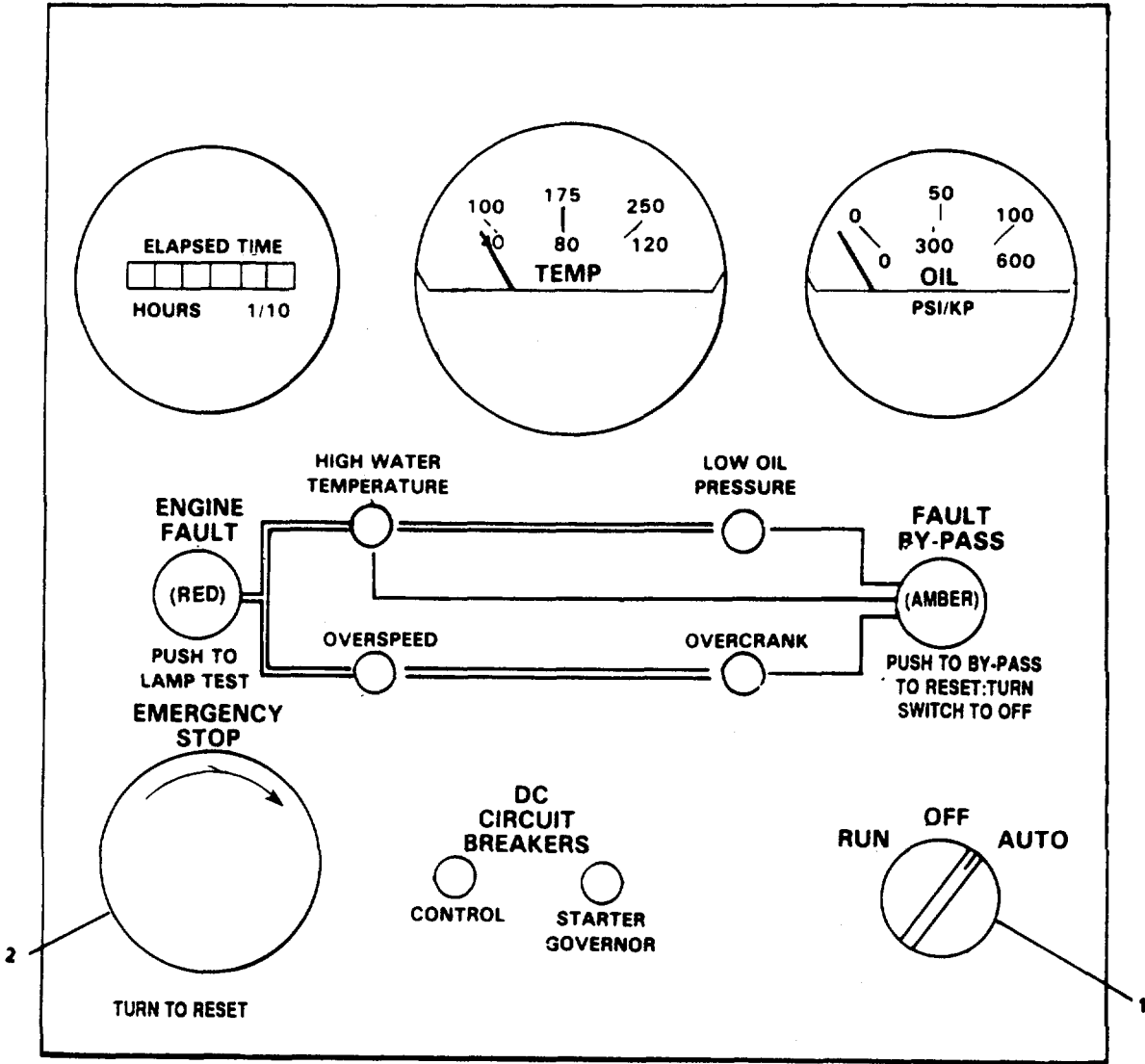

FIGURE 2-243. Main Switchboard



- LEGEND**
- 1. BYPASS SWITCH
  - 2. TRIP
  - 3. MODE SWITCH

FIGURE 2-244. Emergency Switchboard.



- LEGEND**
- 1. RUN-OFF AUTO SWITCH
  - 2. EMERGENCY STOP SWITCH

FIGURE 2-245. Emergency Generator Diesel Engine Control Panel.

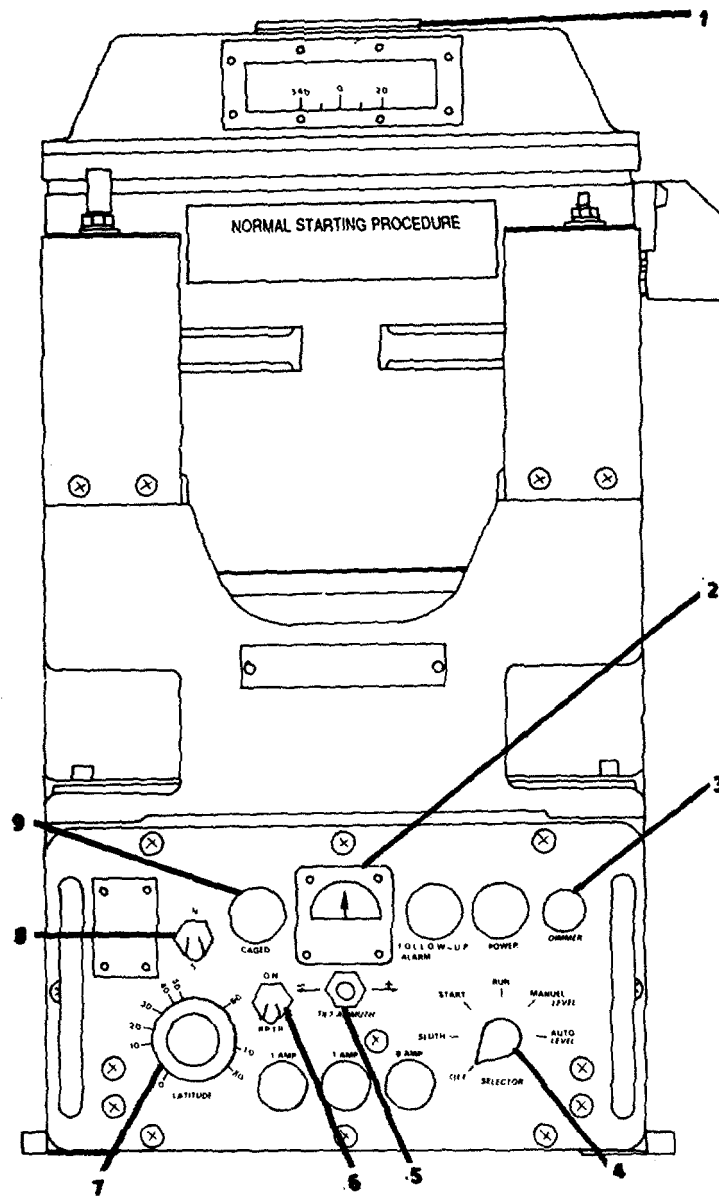

**LEGEND**

- |                 |             |
|-----------------|-------------|
| 1. CAGED BUTTON | 6. RPTR     |
| 2. LEVEL METER  | 7. LATITUDE |
| 3. DIMMER       | 8. N-S      |
| 4. SELECTOR     | 9. CAGED    |
| 5. TILT/AZIMUTH |             |

FIGURE 2-246. Gyro Compass MARK 27 MOD 1 Electronic Control Panel).

## NOTE

The compass card will move away from heading rapidly if a longer period than that indicated in the following steps is allowed between starting and uncaging. If possible, uncage when the hip is at the center of pitch or roll, so that the gyro will be released near a level position.

- (4) Position the SELECTOR switch (4) to START. Wait 30 to 35 seconds, then depress CAGED BUTTON (1), located on top of the binnacle, and note that the CAGED lamp (9) extinguishes.
- (5) Note if the pointer on the LEVEL METER (2) swings equally about zero. If it does, proceed to the next step. If it does not, operate the TILT/AZIMUTH switch (5), in the direction of the required tilt correction, until equal travel about the zero point is obtained.
- (6) Observe the compass card for about 1 minute to determine the direction of card movement with respect to the required course.
  - (a) If the card is moving toward the heading, allow it to continue until it is within 2 degrees of the desired heading, then operate the TILT/AZIMUTH switch (5) to level the gyro and make the average position of the LEVEL METER (2) pointer zero.
  - (b) If the card is moving away from heading, reverse polarity of the average pointer position by operating the TILT/AZIMUTH switch (5). Wait until the direction of card heading, operate the TILT/AZIMUTH switch (5) to level the gyro and make the average position of the LEVEL METER (2) pointer zero.
- (7) Position SELECTOR switch (4) to RUN.
- (8) Position N-S switch (8) to N (north) or S (south) as required.
- (9) Position LATITUDE control (7) to ship's latitude.

## NOTE

If step repeaters are used, they must be synchronized to the compass card before positioning REPEATER switch (6) to ON.

- (10) Wait 10 minutes after uncaging and position RPTR switch (6) to ON if repeaters are used.
- (11) Adjust DIMMER control (3), as required.



b. Emergency Restarting.

## NOTE

The following procedure is to be used if the gyro has dumped, or the compass must be started with the gyro running. This condition is indicated by full scale deflection of the level meter and a rapid slewing of the compass card.

- (1) Position SELECTOR switch (4, FIGURE 2-246) to AUTO LEVEL. Note that compass stops slewing and settles at a random heading.
- (2) Position SELECTOR (4) switch to MANUAL LEVEL.
- (3) Depress CAGED BUTTON (1), located on top of binnacle, and note that CAGED lamp (9) lights.
- (4) Position TILT/AZIMUTH switch (5) in the same direction required to return compass card to the proper heading. Release the switch after the compass card begins to rotate slowly toward the desired heading.
- (5) Allow compass card to rotate 2 or 3 degrees past the required heading, then depress CAGED BUTTON (1) on top of the binnacle. Note that the CAGED lamp (9) extinguishes.
- (6) Position the SELECTOR switch (4) to AUTO LEVEL and note that the gyro comes to an approximate level, as indicated by the LEVEL METER (2).
- (7) Position SELECTOR switch (4) to MANUAL LEVEL, then operate TILT/AZIMUTH switch (5) to obtain a zero indication on the LEVEL METER (2).
- (8) Position SELECTOR switch (4) to RUN.

**Change 2 2-648**

**2-49. Steering System Failure**

- a. If operating on the #1 pump system, select #2 pump system or vice-versa on the PUMP SELECTOR SWITCH on the STEERING CONTROL PANEL (1, FIGURE 2-248.1). Steer vessel at reduced speed until repairs are completed.
- b. If steering is available from only one of the steering subsystems, dispatch an engineer to determine the cause of the loss of steering in the other steering subsystem.
- c. When normal steering from the pilothouse is disabled, control can be transferred to the local control unit in the steering gear room. With communication from the pilothouse, a crew member will select LOCAL on the LOCAL-REMOTE SWITCH on the LOCAL CONTROL UNIT (1, FIGURE 2-248.2).
- d. At direction from the pilothouse, the crew member will move the Non-Follow-up toggle switch (2, FIGURE 2-248.2) port or starboard. The toggle has a spring return to neutral, while rudder travel continues unless a hard over stop is reached.
- e. If emergency hand pump operation is required, shut pumpsets down and open valves M and N (1 and 2 FIGURE 2-248.3). Operate emergency hand pump as ordered from pilothouse.

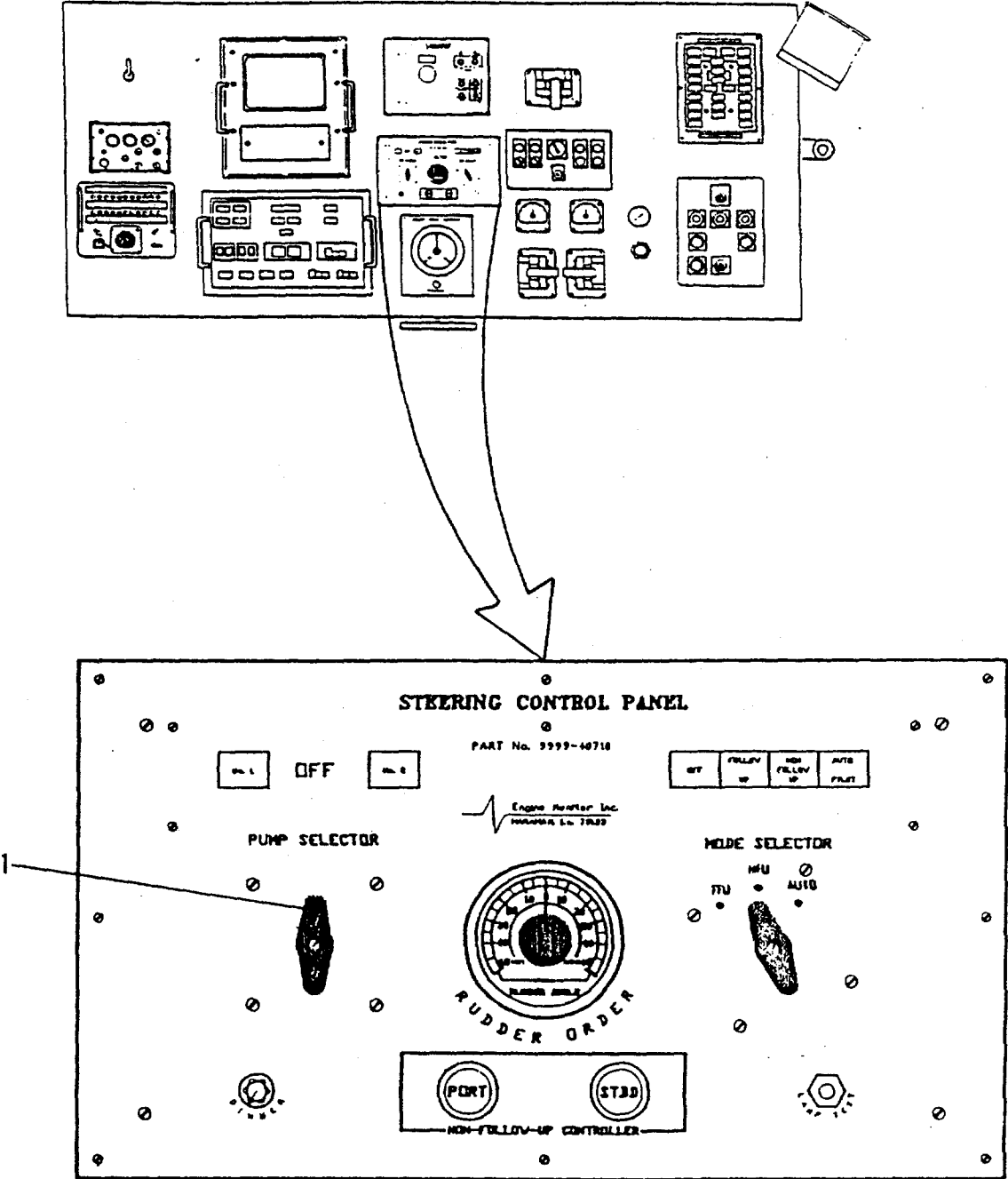

FIGURE 2-248.1. Steering Control Panel

Change 2 2-650

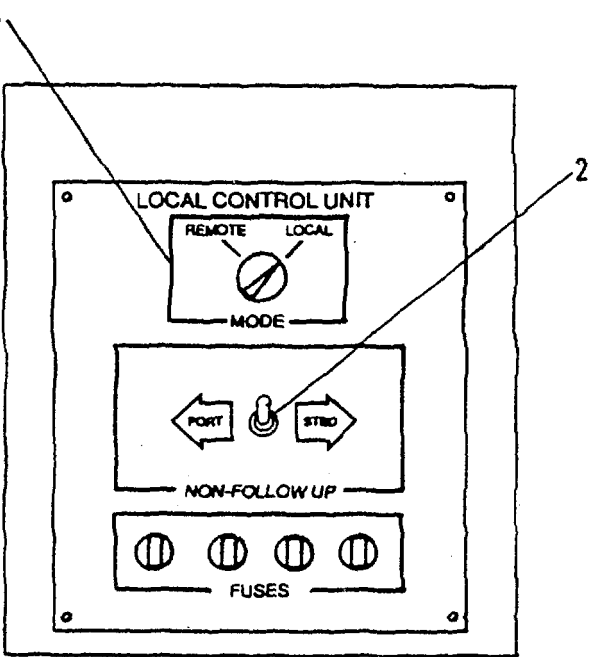

FIGURE 2-248.2. Steering Gear Room Local Control Unit

Change 2 2-650.1

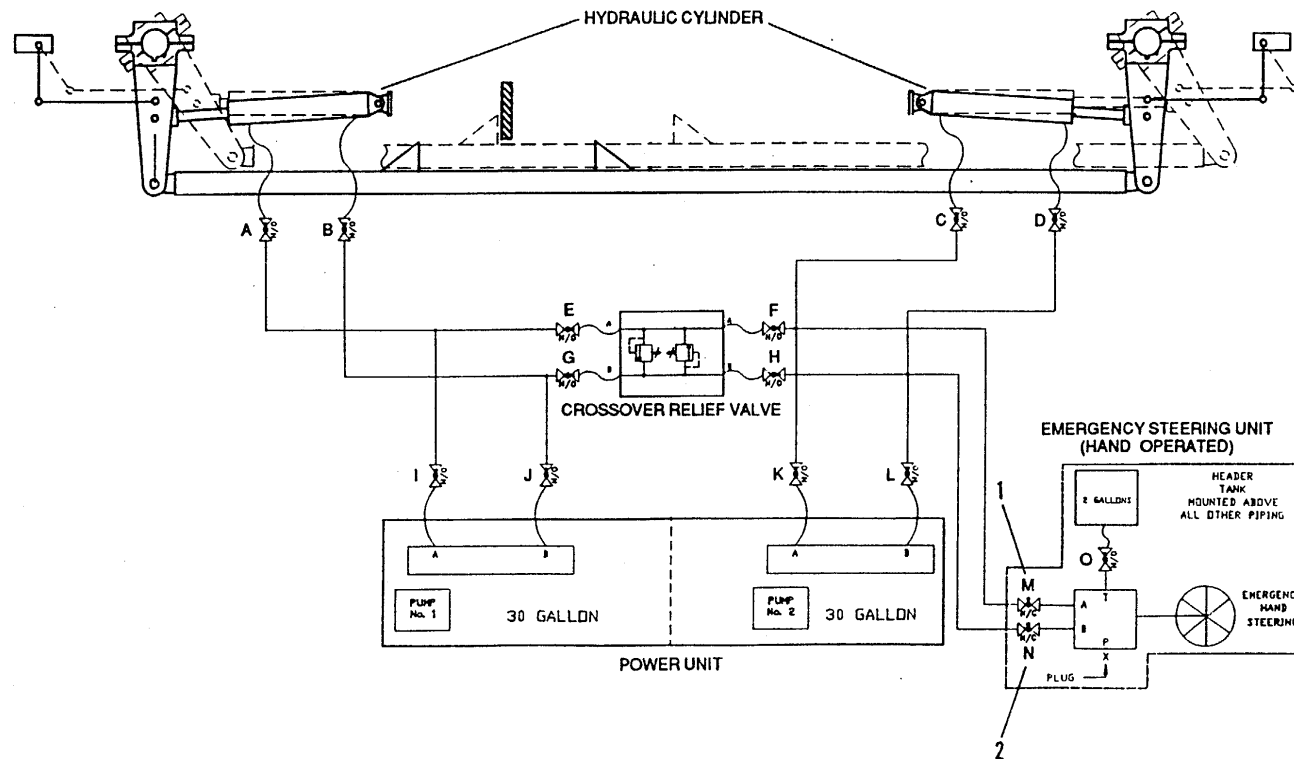

FIGURE 2-248.3. Steering System Hydraulic

Change 2 2-650.2

**2-50. HALON 1301 Fire Suppression System.****NOTE**

**Not applicable to vessels with FM-200 Fire Suppressant System installed. Reference paragraph 2-63 through 2-64 for FM-200 and Water Washdown System operation. Reference TM 55-1905-243-24&P, LCU-2000, FM-200 Fire Fighting System for maintenance and installation of FM-200 components.**

## a. Manual Release for Fire in Main Machinery Room.

- (1) Close all doors to protected area.

**WARNING**

**HALON 1301 may produce toxic byproducts while extinguishing fire. Where possible, the area in which the HALON discharge took place should be left secured for a minimum of 30 minutes. Personnel should wear protective clothing and oxygen breathing apparatus (OBA) upon reentry.**

- (2) Open ½" globe valve (2, FIGURE 2-250), located in emergency generator compartment, by operating release lever (remove pin and pull lever).
- (3) Open 50 lb. CO<sup>2</sup> cylinder by operating cylinder release lever (3), located on side of cylinder valve. (Remove pin and pull lever.)

**NOTE**

**Alarm siren will sound in main machinery room and discharge of HALON will be delayed for 60 seconds to allow evacuation of area that is to be protected.**

- (4) Bypass of 60-second discharge delay.
  - (a) Pull out locking pin.
  - (b) Pull manual release lever on 60-second discharge delay (1) to open.

## b. Manual Release for Fire in Paint Locker.

**WARNING**

**HALON 1301 may produce toxic byproducts while extinguishing fire. Where possible, the area in which the HALON discharge took place should be left secured for a minimum of 30 minutes. Personnel should wear protective clothing and oxygen breathing apparatus (OBA) upon reentry.**

- (1) Open ½" globe valve (2, FIGURE 2-250), located at paint locker AFT bulkhead. Turn counterclockwise.
- (2) Close door to protected area.
- (3) Open 50 lb. CO<sup>2</sup> cylinder by operating cylinder release lever (3), located on top of cylinder by raising to upright position.



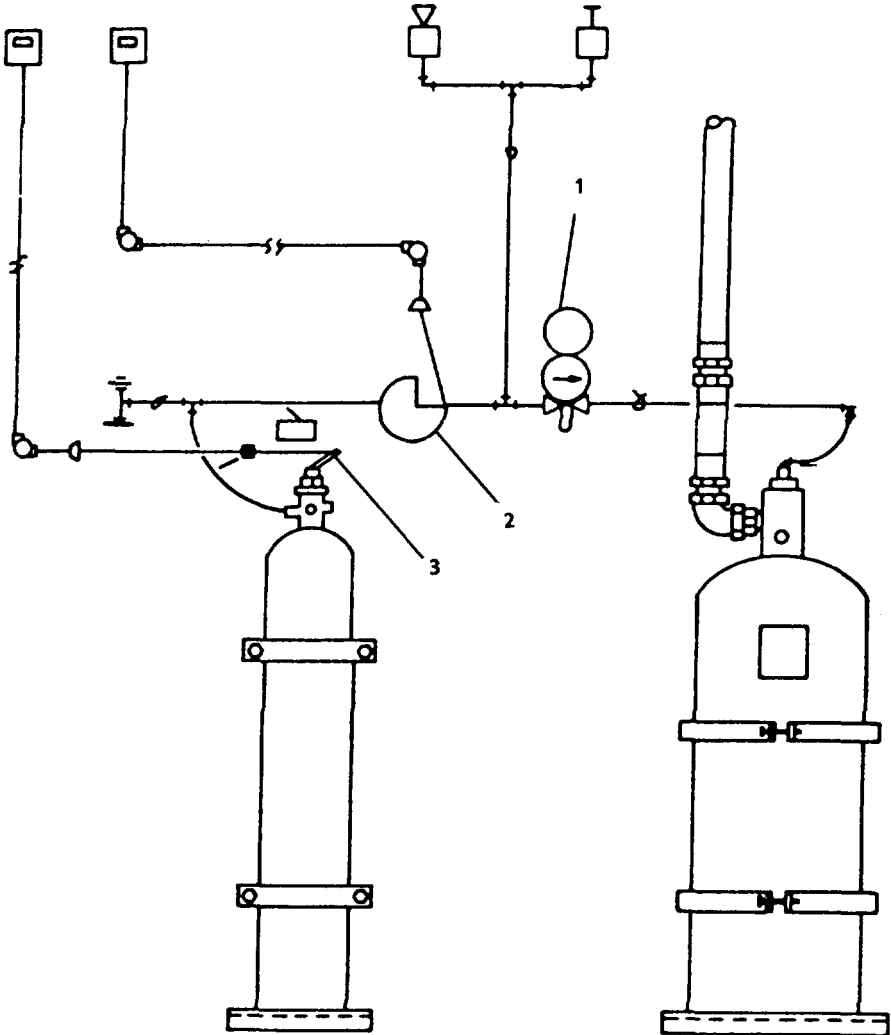

- LEGEND**
- 1. 60 SEC. TIME DELAY
  - 2. ½ INCH GLOBE VALVE
  - 3. CO<sub>2</sub> LEVER RELEASE

FIGURE 2-250. HALON 1301 Fire Suppression System.



## NOTE

Alarm siren will sound in paint locker and discharge of HALON will be, delayed for 60 seconds to allow evacuation of area that is to be protected.

(4) Bypass of 60-second discharge delay.

(a) Pull manual release lever on 60-second discharge delay (1) to open.

(b) Open 1/2" glove valve (2, FIGURE 2-250) located at paint locker bulkhead.

(c) Close door to protected area.

(d) Open 50 lb. CO<sub>2</sub> cylinder by operating cylinder release lever (3), located on top of cylinder by raising to upright position.

### 2-51. Deballasting Using Fire Pumps.

a. Valve Alignment for Discharge (FIGURE 2-251).

(1) Open BB-18, OVBD D,SCH (7).

(2) Open BB-27, TO OVBD DISCH (8).

(3) Align valves for tanks to be deballasted as follows:

(a) SW-1 CL, SW-2P, and/or SW-2S:

1 Open BB-15, SUCT FR SW-1 and SW-2S and SW-2P (1).

2 For SW-1CL, open BB-1, ISLN TK SW-1 (37).

3 For SW-2P, open BB-2, ISLN TK SW-2P (36).

4 For SW-2S, open BB-3, ISLN TK SW-2S (38).

(b) SW-5P and/or SW-5S:

1 Open BB-7, SUCT FR SW-5S AND SW-5P (3).

2 For SW-5P, open BB-4, ISLN TK SW-5P (40).

3 For SW-5S, open BB-5, ISLN TK SW-5S (39).

(c) SW-8P and/or SW-8S:

1 Open BB-11, SUCT FR SW-8S AND SW-8P (2).

2 For SW-8P, open BB-20, ISLN-TK SW-8P (35).

3 For SW-8S, open BB-21, ILSN-TK SW-8S (19).

(4) Open FM-17, FIRE PUMP NO. 2 SUCT (13).

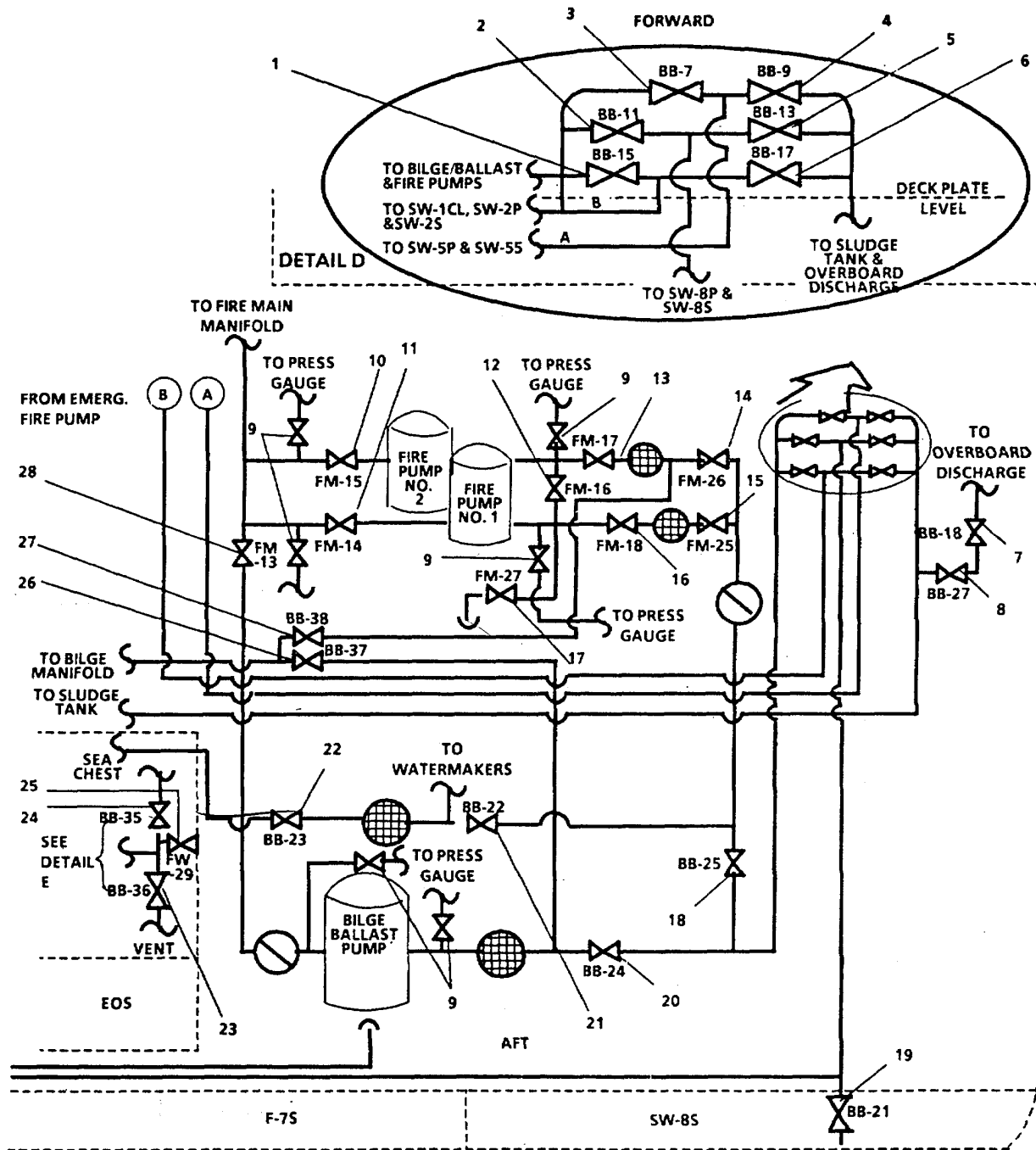

FIGURE 2-251. Deballasting Using Fire Pumps (Sheet 1 of 6).

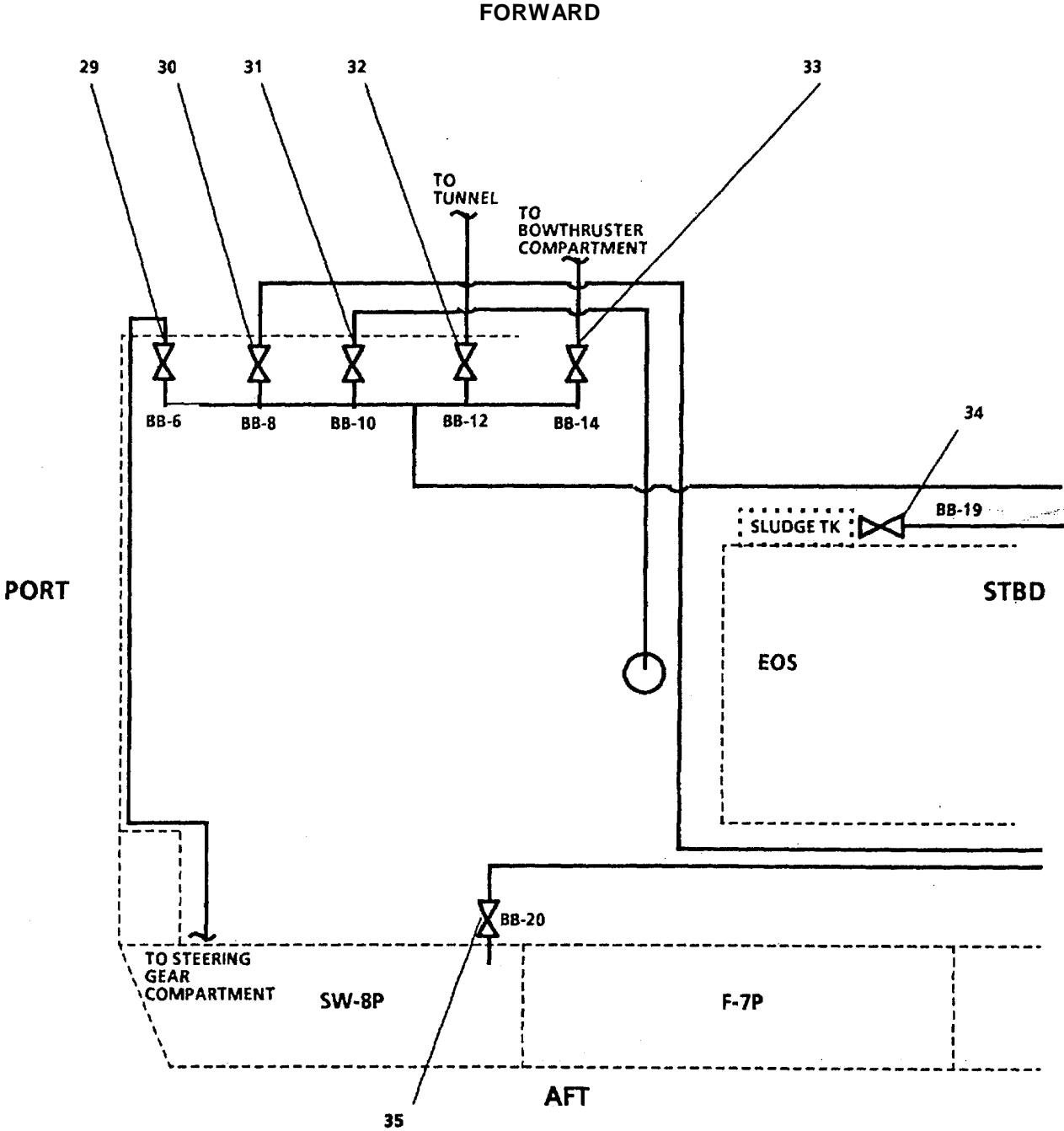

FIGURE 2-251. Deballasting Using Fire Pumps (Sheet 2 of 6).

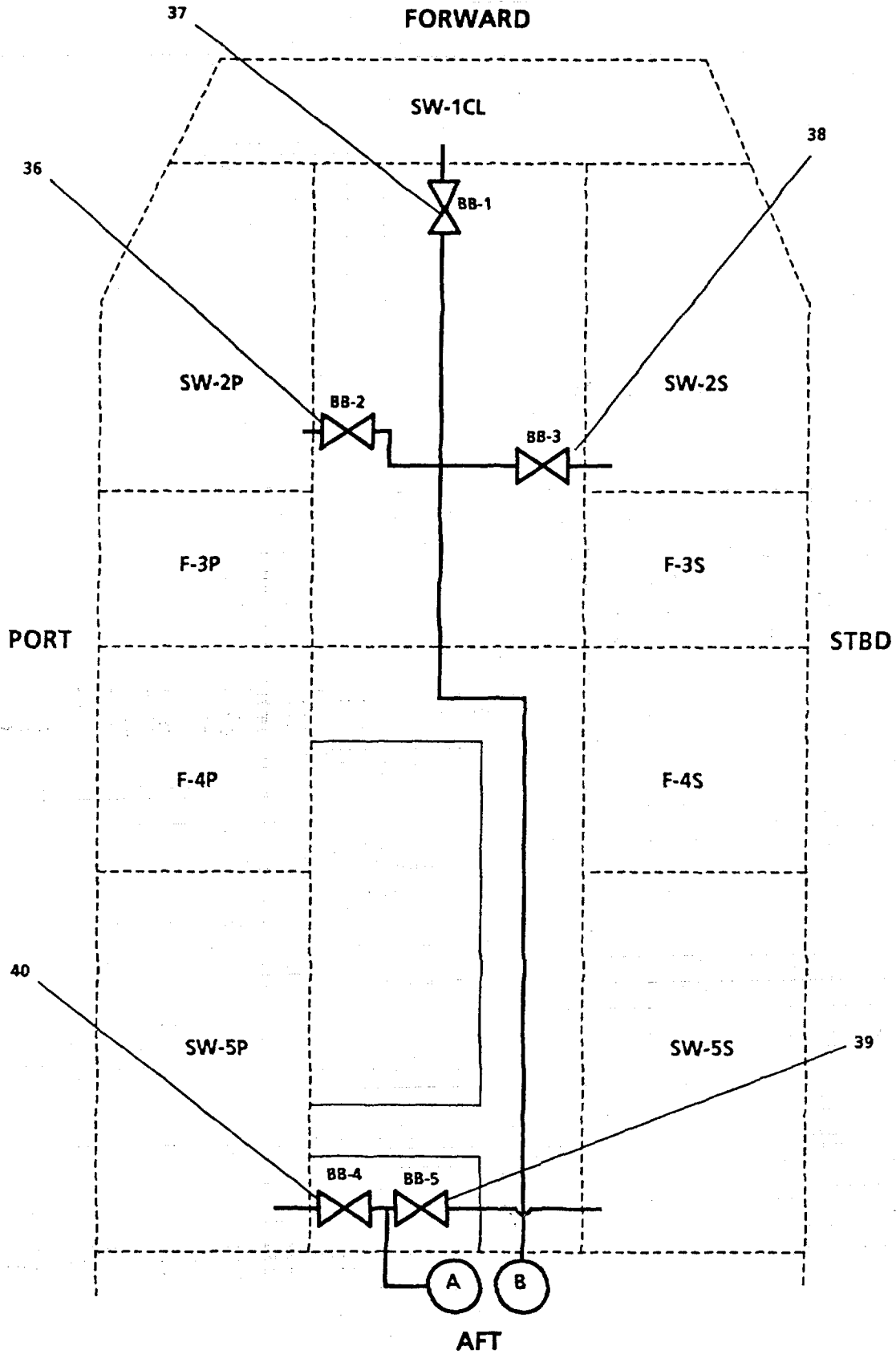

FIGURE 2-251. Debballasting Using Fire Pumps (Sheet 3 of 6).  
2-657

DETAIL F

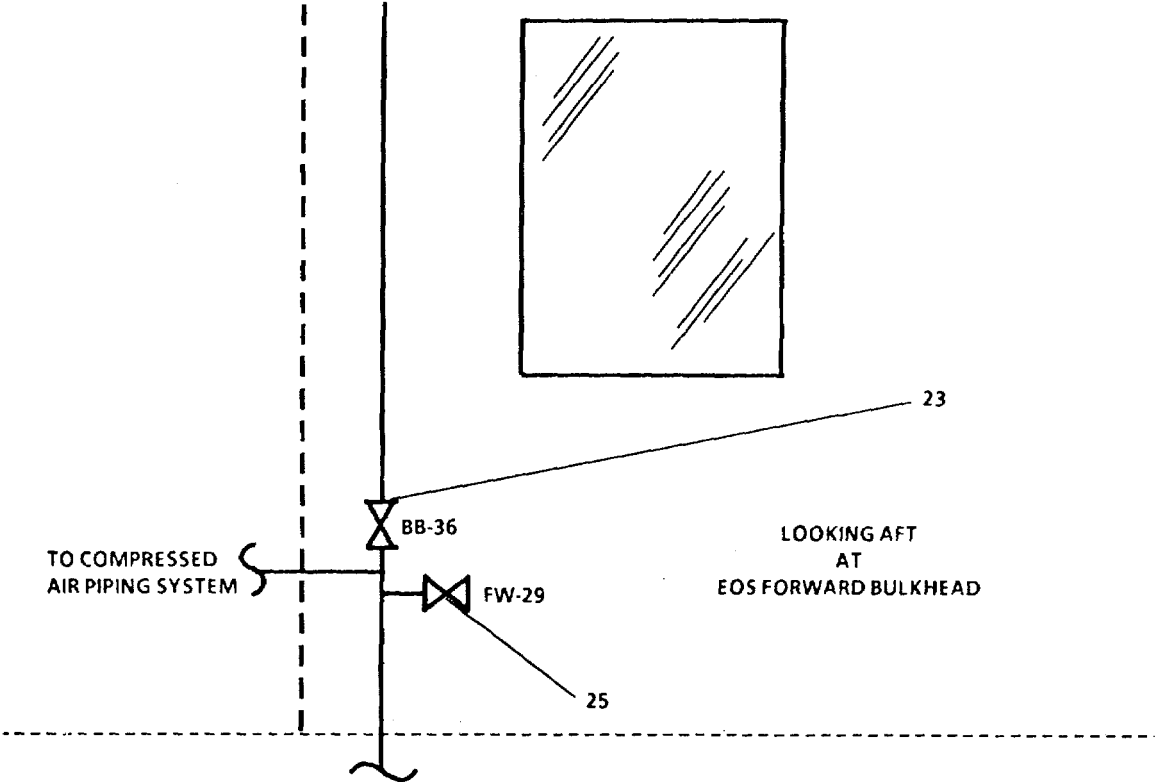
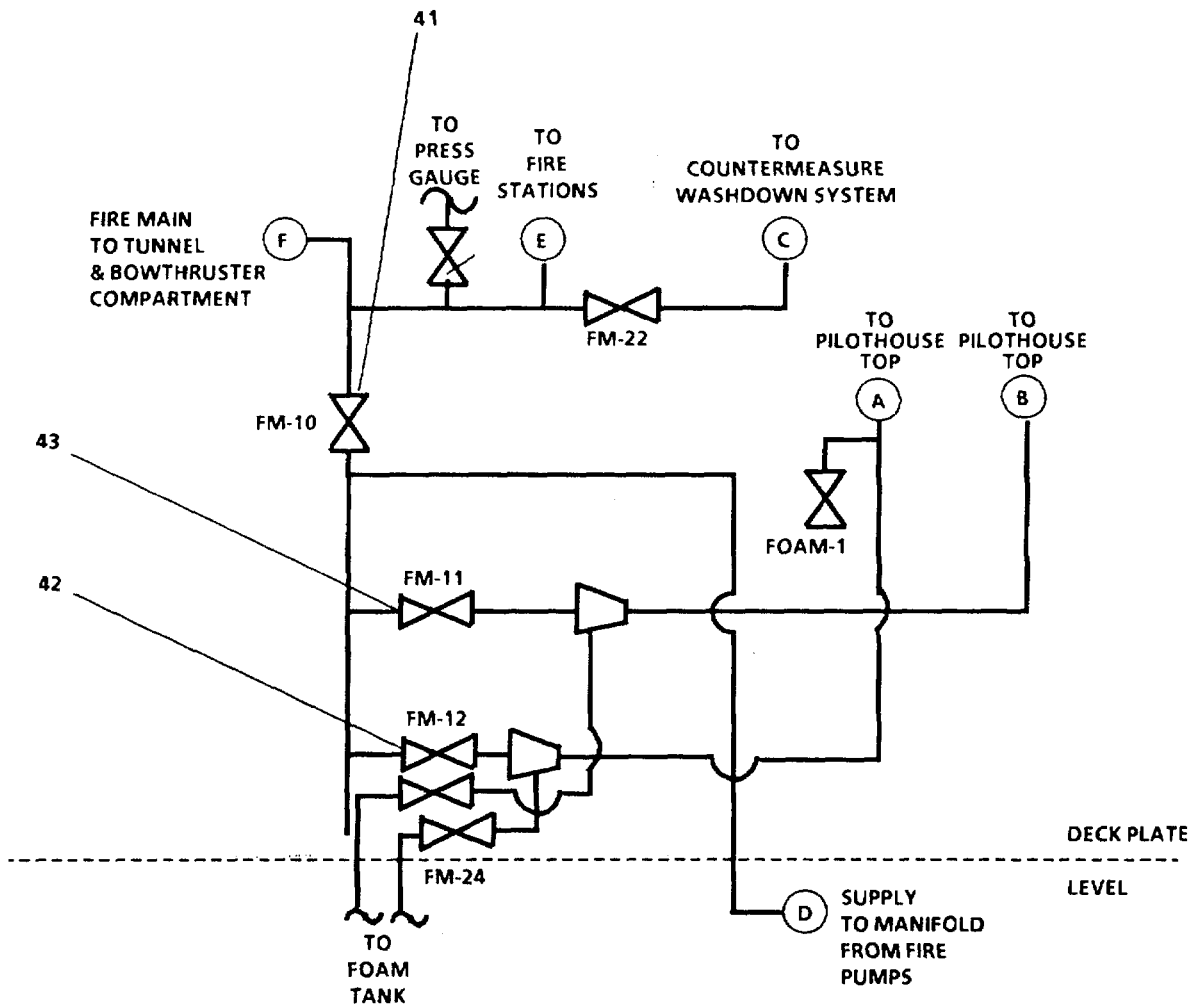
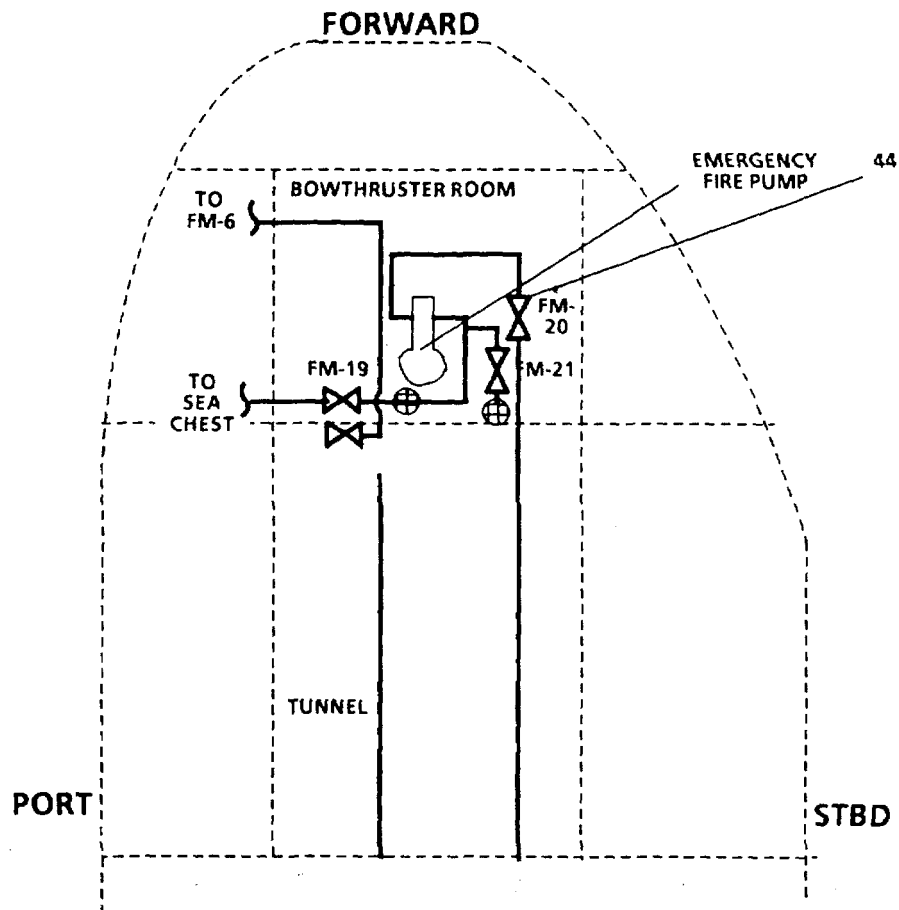

FIGURE 2-251. Deballasting Using Fire Pumps (Sheet 4 of 6).



**LOOKING STARBOARD AT PORT BULKHEAD OF STOREROOM**

FIGURE 2-251. Deballasting Using Fire Pumps (Sheet 5 of 6).



**LEGEND**

- |  |  |
|--|--|
| <ul style="list-style-type: none"> <li>1. BB-15, SUCT FR SW-1 &amp; SW-2S &amp; SW-2P</li> <li>2. BB-11, SUCT FR SW-8S &amp; SW-8P</li> <li>3. BB-7, SUCT FR SW-5S &amp; SW-5P</li> <li>4. BB-9, SUPPLY TO SW-5S &amp; SW-5P</li> <li>5. BB-13, SUPPLY TO SW-8S &amp; SW-8P</li> <li>6. BB-17, SUPPLY TO SW-1 &amp; SW-2S &amp; SW-2P</li> <li>7. BB-18, TO OVBD DISCH</li> <li>8. BB-27, TO OVBD DISCH</li> <li>9. PRESSURE GAUGE ISOLATION</li> <li>10. FM-15, NO. 2 FIRE PUMP DISCH</li> <li>11. FM-14, NO. 1 FIRE PUMP DISCH</li> <li>12. FM-16, FIRE PUMP 1&amp;2 SUCT CROSS CONN</li> <li>13. FM-17, FIRE PUMP NO. 2 SUCT</li> <li>14. FM-26, NO. 2 FIRE PUMP STRAINER ISOLATION</li> <li>15. FM-25, NO. 1 FIRE PUMP STRAINER ISOLATION</li> <li>16. FM-18, FIRE PUMP NO. 1 SUCT</li> <li>17. FM-27, ENG RM EMERG BILGE SUCT</li> <li>18. BB-25, ISLN-SEA CHEST</li> <li>19. BB-21, ISLN-TK SW-8S</li> <li>20. BB-24, SUCT-BILGE/BALLAST PUMP</li> <li>21. BB-22, ISLN - SEA CHEST</li> <li>22. BB-23, SEA CHEST SUCT</li> <li>23. BB-36, SEACHEST VENT</li> </ul> | <ul style="list-style-type: none"> <li>24. BB-35, SEACHEST VENT ISOLATION</li> <li>25. FW-29, SEA CHEST HOT FW CONN</li> <li>26. BB-37, CROSS CONN TO BILGE MANIFOLD</li> <li>27. BB-38, CROSS CONN FIRE PUMP SUCT TO BILGE MANIFOLD</li> <li>28. FM-13, FIREMAN &amp; BALLAST CROSS CONN</li> <li>29. BB-6, BILGE SUCT-STRG GR COMPT</li> <li>30. BB-8, BILGE SUCT-ENG RM STBD</li> <li>31. BB-10, BILGE SUCT-ENG RM PORT</li> <li>32. BB-12, BILGE SUCT-TUNNEL</li> <li>33. BB-14, BILGE SUCT BOWTHRUSTER ENG RM</li> <li>34. BB-19, DISCH TO SLUDGE TK</li> <li>35. BB-20, ISLN-TK SW-8P</li> <li>36. BB-2, ISLN TK SW-2P</li> <li>37. BB-1, ISLN TK SW-1</li> <li>38. BB-3, ISLN TK SW-2S</li> <li>39. BB-5, ISLN TK SW-5S</li> <li>40. BB-4, ISLN TK SW-5P</li> <li>41. FM-10, FIREMAIN ISLN</li> <li>42. FM-12, FOAM STA 1 &amp; STBD MONITOR ISLN</li> <li>43. FM-11, FOAM STA 2 &amp; PORT MONITOR ISLN</li> <li>44. FM-20, EMERG FIRE PUMP DISCH</li> </ul> |
|--|--|

FIGURE 2-251. Deballasting Using Fire Pumps (Sheet 6 of 6).

- (5) Open FM-26, NO. 2 FIRE PUMP STRAINER ISOLATION (14).
- (6) Open FM-18, FIRE PUMP NO. 1 SUCT (16).
- (7) Open FM-25, NO. 1 FIRE PUMP STRAINER ISOLATION (15).
- (8) Open FM-15, NO. 2 FIRE PUMP DISCH (10).
- (9) FM-14, NO. 1 FIRE PUMP DISCH (11).
- (10) Open FM-13, FIRE MAIN & BALLAST CROSS CONN (28).
- (11) Ensure the following valves are closed:
  - (a) BB-19, DISCH TO SLUDGE TK (34).
  - (b) FM-12, FOAM STA 1 & STBD MONITOR ISLN (42).
  - (c) FM-11, FOAM STA 2 & PORT MONITOR ISLN (43).
  - (d) FM-10, FIREMAIN ISLN (41).
  - (e) FM-20, EMER FIRE PUMP DISCH (44).
  - (f) BB-38, CROSS CONN FIRE PUMP SUCT TO BILGE MANIFOLD (27).
  - (g) BB-37, CROSS CONN SUCT TO BILGE MANIFOLD (26).
  - (h) BB-24, SUCT-BILGE BALLAST PUMP (20).
- b. Operate fire pumps by pressing START (1, FIGURE 2-252) on fire pump motor switches.
- c. When the selected tank has reached the desired level on the tank level indicator (located in the starboard-forward corner of the engine room) press the STOP pushbutton (2).
- d. Restore Valve Alignment (FIGURE 2-251).
  - (1) Close the following valves:
    - (a) BB-18, OVBD DISCH (37).
    - (b) BB-27, TO OVBD DISCH (8).
    - (c) BB-15, SUCT FR SW-1 AND SW-2S AND SW-2P (1).
    - (d) BB-1, ISLN TK SW-1 (37).
    - (e) BB-2, ISLN TK SW-2P (36).
    - (f) BB-3 ISLN TK SW-2S (38).
    - (g) BB-7, SUCT FR SW-5S AND SW-5P (3).



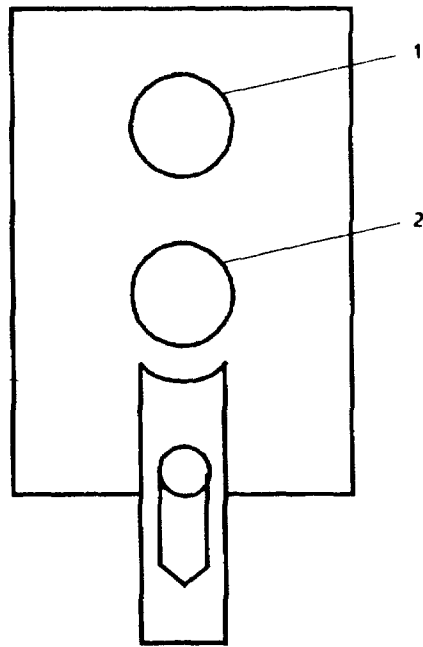

**LEGEND**

- 1. START
- 2. STOP

*FIGURE 2-252. Fire Pump Motor Switch.*

2-662

- (h) BB-4, ILSN TK SW-5P (40).
- (i) BB-5, ISLN TK SW-5S (39).
- (j) BB-11, SUCT FR SW-8S AND SW-8P (2).
- (k) BB-20, ISLN-TK SW-8P (35).
- (l) BB-21, ISLN-TK SW-8S (19).
- (m) FM-17, FIRE PUMP NO. 2 SUCT (13).
- (n) FM-26, NO. 2 FIRE PUMP STRAINER ISOLATION (14).
- (o) FM-18, FIRE PUMP NO. 1 SUCT (16).
- (p) FM-25, NO. 1 FIRE PUMP STRAINER ISOLATION (15).
- (q) FM-15, NO. 2 FIRE PUMP DISCH (10).
- (r) FM-14, NO. 1 FIRE PUMP DISCH (11).
- (s) FM-13, FIRE MAIN & BALLAST CROSS CONN (28).

(2) Open the following valves:

- (a) FM-12, FOAM STA 1 & STBD MONITOR ISLN (41).
- (b) FM-11, FOAM STA 2 & PORT MONITOR ISLN (42).
- (c) FM-10, FIREMAIN ISLN (43).

## 2-52. Bow Ramp.

### **WARNING**

Before operating bow ramp winch, ensure that personnel and foreign objects are clear of wire rope, bow ramp, and related components. Moving winch and ramp parts can cause serious injury or death.

#### a. Manual Operation.

(1) Preparation for operation.

- (a) At Main Switchboard (FIGURE 2-253), set BOW RAMP WINCH circuit breaker (1) to OFF and tag OUT OF SERVICE.
- (b) Install EMERGENCY HANDCRANK hub (2, FIGURE 2-254) on winch hydraulic motor. Engage EMERGENCY HANDCRANK hub onto motor and secure in place with three capscrews.

### **WARNING**

If emergency hand crank hub is not engaged, ramp may free fall.

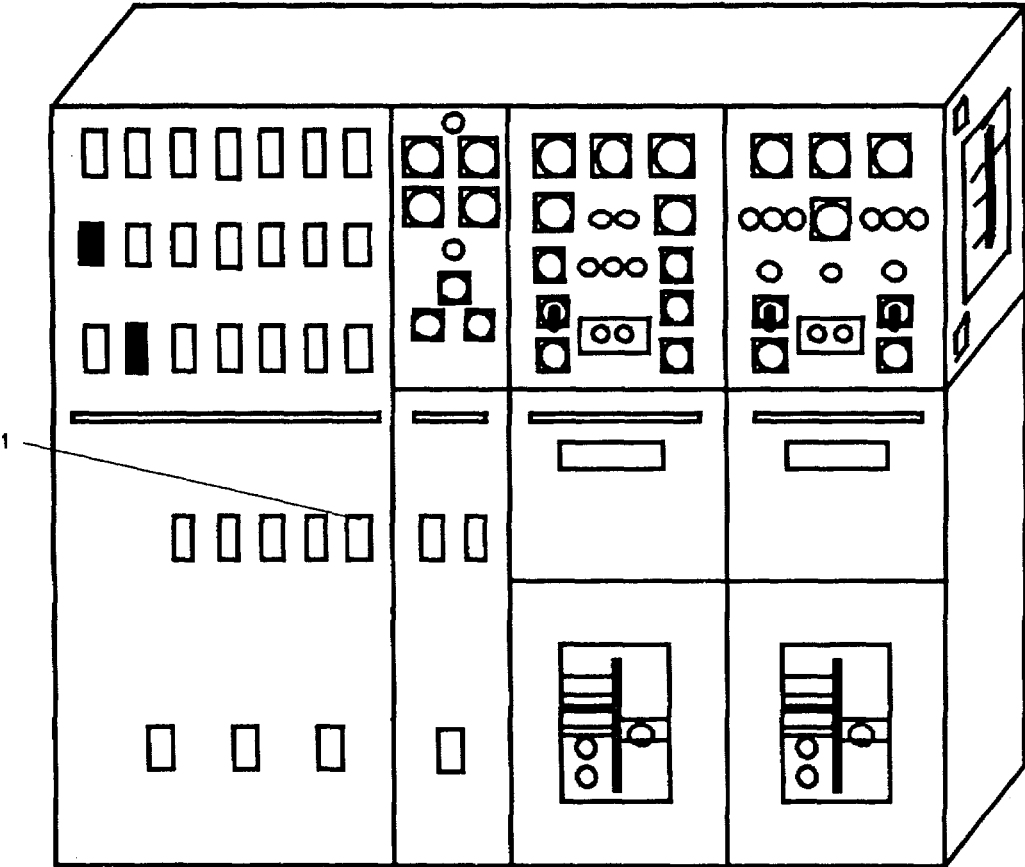

**LEGEND**  
1. BOW RAMP WINCH

FIGURE 2-253. Main Switchboard.

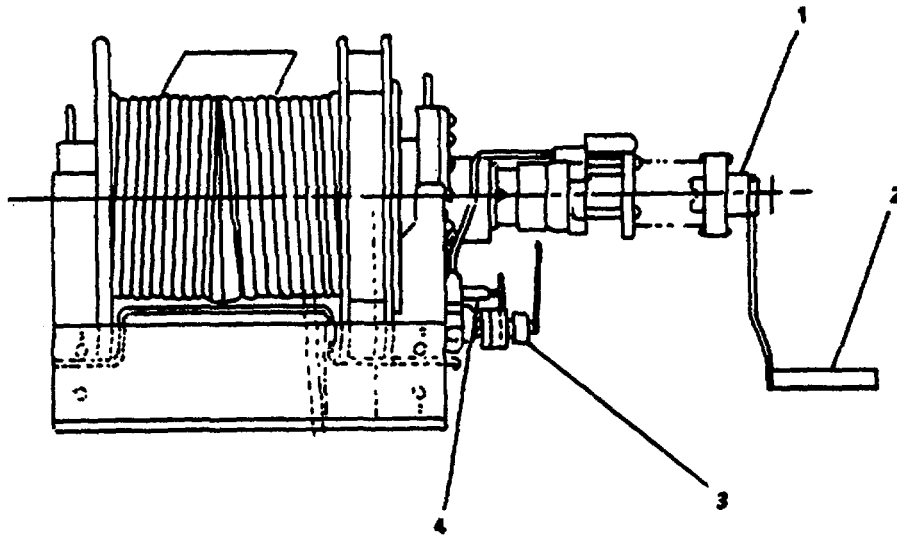

**LEGEND**

- 1. EMERGENCY HANDCRANK HUB**
- 2. EMERGENCY HANDCRANK**
- 3. HYDRAULIC HAND PUMP**
- 4. CROSS CONNECT**

*FIGURE 2-254. Bow Ramp System.*

- (c) Open CROSS CONNECT (4) valve by fully turning in a counter clockwise direction.
  - (d) Operate HYDRAULIC HAND PUMP (3) to override the hydraulic failsafe brake. Approximate 20 strokes will release brake.
- (2) Lower Bow Ramp.

**WARNING**

- Before operating-bow ramp winch, ensure personnel and foreign objects are clear of wire rope drum, wire rope, bow ramp, and related components. Moving winch and ramp parts can cause serious injury or death.
- Clear all personnel and equipment from bow ramp and bow ramp path of travel. Moving ramp can cause serious personal injury.

**NOTE**

Sound powered telephones must be used for coordination of actions on Forecastle Deck and Boatswains Storage.

- (a) Direct one crew member to starboard forecastle deck and another crew member to port forecastle deck.
- (b) Turn EMERGENCY HANDCRANK (2) counterclockwise to tighten rig and take load off Bow Ramp Locking Assembly.
- (c) Direct crew members on forecastle decks to turn RATCHET HANDLE (3, FIGURE 2-255, of locking assembly to release LOCKING CLAMP (2).
- (d) Direct crew members on forecastle decks to remove LOCKOUT PIN (5) and pull CHAIN STOPPER HANDLE (4) aft to release port and starboard CHAIN STOPPER (1) and prevent chain stopper from engaging chain during operation.
- (e) Turn EMERGENCY HANDCRANK (2, FIGURE 2-254) clockwise to lower ramp.

**NOTE**

Approximately 1450 turns are required to completely haul-in or payout 25 feet of cable.

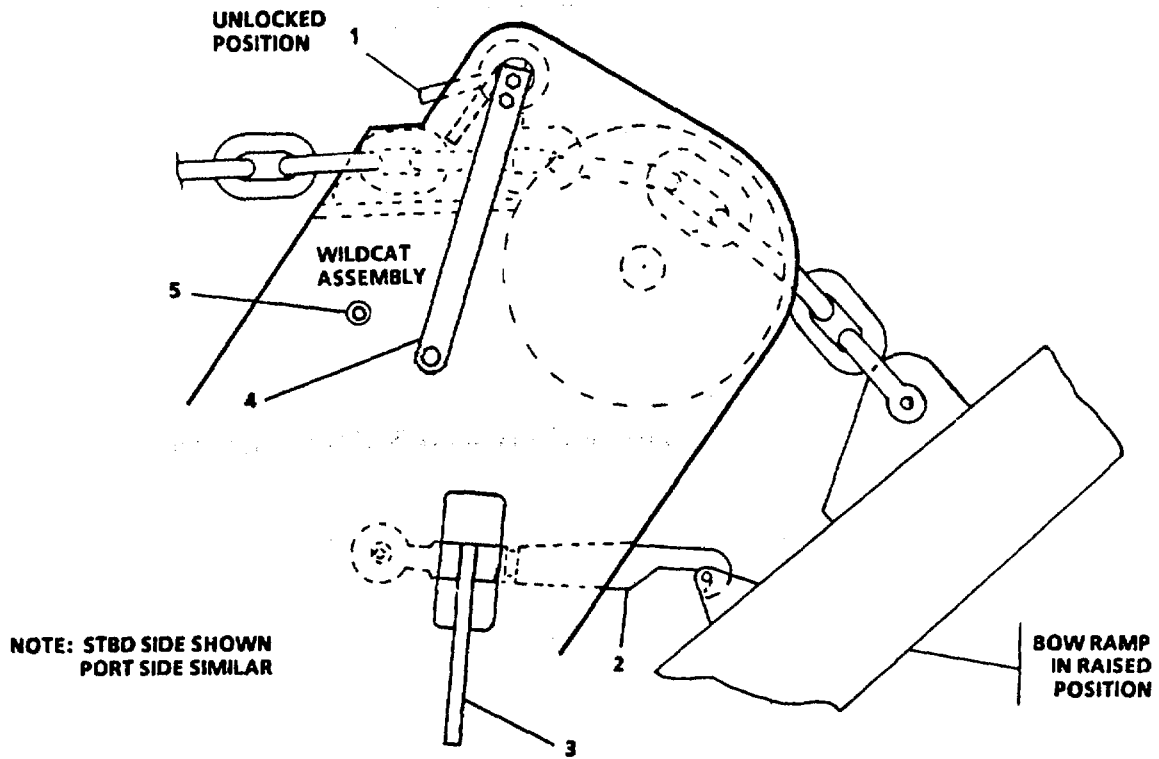

**LEGEND**

- |                   |                         |
|-------------------|-------------------------|
| 1. CHAIN STOPPER  | 4. CHAIN STOPPER HANDLE |
| 2. LOCKING CLAMP  | 5. LOCKOUT PIN          |
| 3. RATCHET HANDLE |                         |

FIGURE 2-255. Bow Ramp Locking Assembly.

## (3) Raise Bow Ramp.

**WARNING**

- Before operating bow ramp winch, ensure personnel and foreign objects are clear of wire rope drum, wire rope, bow ramp, and related components. Moving winch and ramp parts can cause serious personnel injury.
- Clear all personnel and equipment from bow ramp and bow ramp path of travel. Moving ramp can cause serious personal injury.

**NOTE**

Sound powered telephones must be used for coordination of actions on Forecastle Deck and Boatswain Storage.

- (a) Direct one crew member to port forecastle deck and another crew member to starboard forecastle deck.
- (b) Direct crew members on forecastle decks to pull CHAIN STOPPER HANDLE (4, FIGURE 2-255) forward to set port and starboard CHAIN STOPPER (1).

**CAUTION**

CHAIN STOPPER should be during ramp raising. As each link in chain passes, chain stopper will slip into next link as links move toward winch. This protects windlass in event of hydraulic failure. LOCKOUT PIN (5) must be left out to prevent damage to handle.

- (c) Turn EMERGENCY HANDCRANK (2, FIGURE 2-254) counterclockwise to raise ramp.

**NOTE**

Ratchet handle has reversible yoke which must be properly positioned down to tighten.

- (d) Direct crew members on forecastle decks to turn ratchet handle (3, FIGURE 2-255) and secure LOCKING CLAMP (2) on the ramp stud. Install LOCKOUT PIN (5).

**NOTE**

Approximately 1450 turns are required to completely haul-in or pay-out 25 feet of cable.

b. After Manual Operation

- (1) Ensure CHAINSTOPPER (1), LOCKING CLAMP (2), and LOCKOUT PIN (5) are secure.
- (2) Pull hydraulic pressure release valve, located on side of HAND PUMP (3), to engage hydraulic failsafe brake.

- (3) Close CROSS CONNECT (4) valve by fully turning in a clockwise direction.
- (4) Remove three capscrews securing EMERGENCY HANDCRANK (2) TO WINCH.
- (5) Remove EMERGENCY HANDCRANK (2).
- (6) Reinstall EMERGENCY HANDCRANK ON storage bracket and secure with three capscrews.
- (7) Reinstall cover on winch.
- (8) Remove tag from main switchboard.

**2-53. Main Engine Cold Weather Starting.**

a. Engine, Block Heaters

**NOTE**

Engine jacket water heaters (block heaters) should be turned on at least 4 hours, but preferably 24 hours prior to starting the engine.

- (1) On Main Switchboard (FIGURE 2-256) ensure AUX MACHRY MCC circuit breaker (1) is in the ON position.
- (2) On Auxiliary Machinery Motor Control Center (FIGURE 2-257) ensure STBD MAIN ENGINE JACKET WATER HEATER circuit breaker (3) and PORT MAIN ENGINE JACKET WATER HEATER circuit breaker (4) are in the ON position.
- (3) After one hour, place your hand near, but not on engine block; warmth should be felt.

b. Preheat Lubrication Oil

**CAUTION**

- Due to the limited capacity of the purifier pumps, only oil from one engine at a time can be heated or purified.
- Clarifier can operate as a separator also; however, operation as a separator WILL VOID WARRANTY. Do not pour water into bowl upon start-up.

- (1) Align power distribution system.
  - (a) On Main Switchboard (FIGURE 2-256) ensure AUX MACHRY MCC circuit breaker (1) is in the ON position.
  - (b) On Auxiliary Machinery Motor Control Center (FIGURE 2-257) set L.O. PURIFIER circuit breaker (1) to the ON position.
  - (c) Set L.O. PURIFIER HEATER circuit breaker (2) to the ON position.



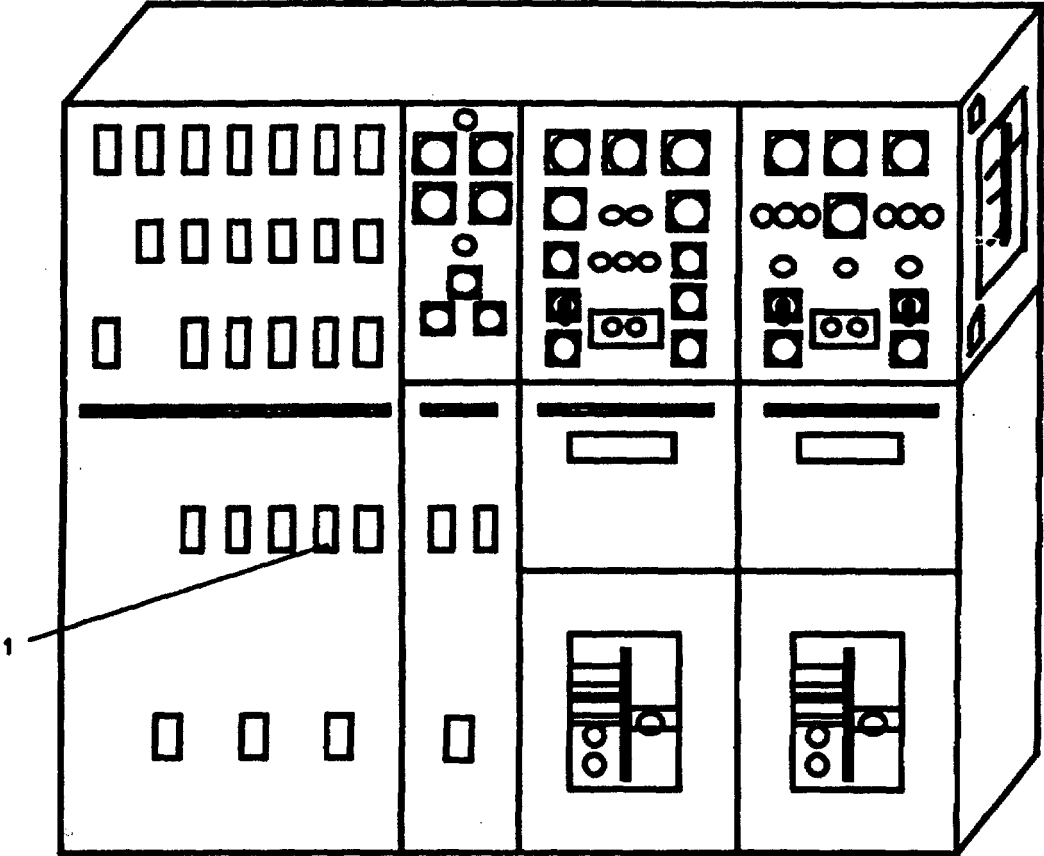

LEGEND  
1. AUX MACHRY MCC

FIGURE 2-256. Main Switchboard.

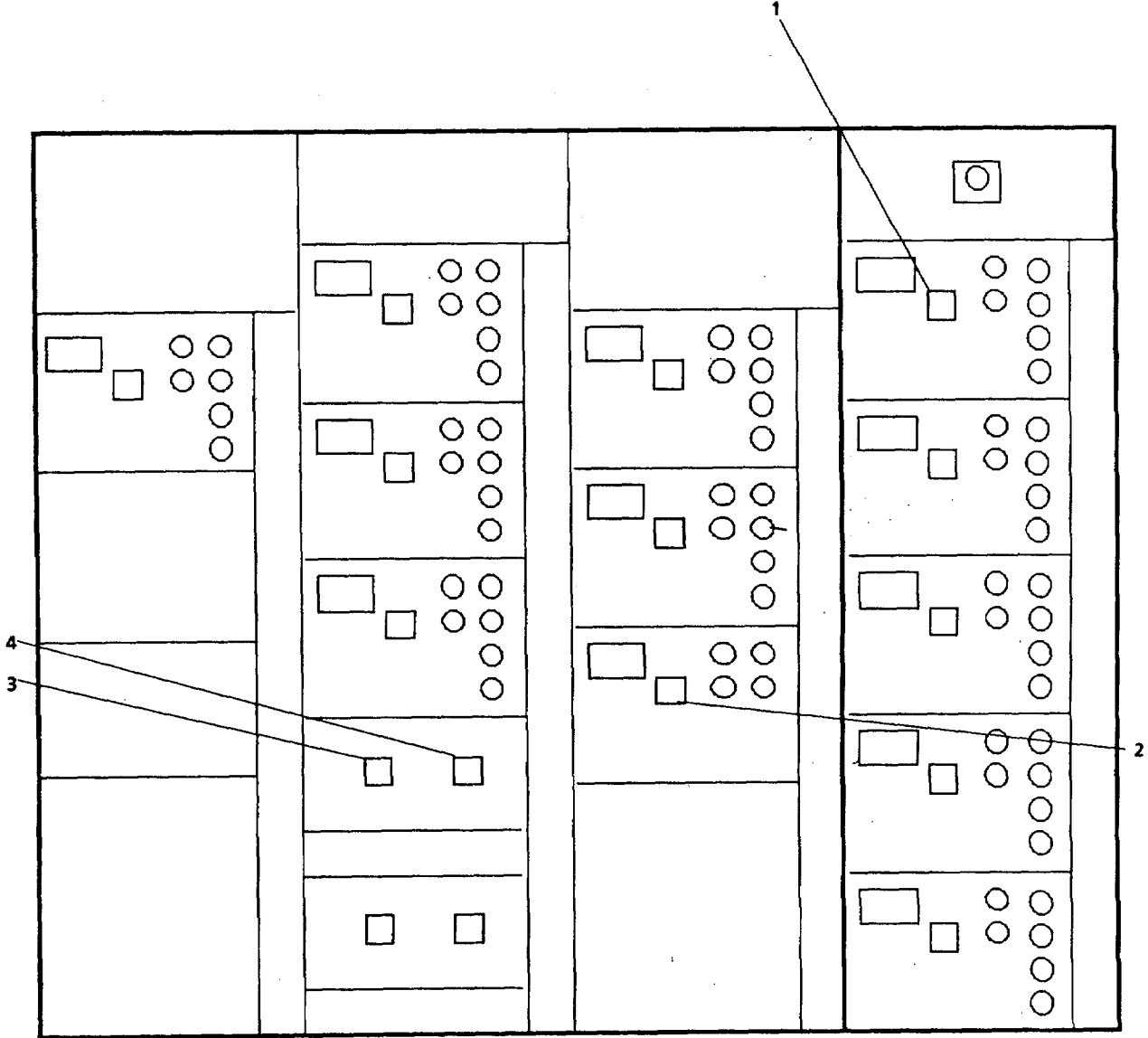

**LEGEND**

- 1. L. O. PURIFIER
- 2. L. O. PURIFIER HEATER
- 3. STBD MAIN ENGINE JACKET WATER HEATER
- 4. PORT MAIN ENGINE JACKET WATER HEATER

FIGURE 2-257. Auxiliary Machinery Motor Control Center.

**NOTE**

L.O. Purifier Heater is used if engine oil temperature is below 180°F.

- (d) On Lube Oil Heater TYPE-I Motor Switch (FIGURE 2-258) release LOCK (3), press START pushbutton (1).
- (2) Align lube oil system for purification.
- (a) If L.O. Purifier Heater is to be used, open LO-9, PRE-HEATER SUPPLY (27, FIGURE 2-259) and LO-8, PRE-HEATER OUTLET (26).
  - (b) If L.O. Purifier Heater is NOT to be used, open LO-7, PRE-HEATER BY-PASS (29).
  - (c) If STBD Main Engine lube oil is to be purified:
    - 1 Open LO-19, SUMP SUCT-STBD ENG (17).
    - 2 Open LO-15, PRE-LUBE/PURIFIER SUCT (23).
    - 3 Open LO-25, SUMP SUPPLY/PURIFIER RTN STBD ENG (15).
    - 4 Ensure LO-17, RDCN GEAR SUCT-STBD (22).
  - (d) If Port Main Engine lube oil is to be purified:
    - 1 Open LO-18, SUMP SUCT-PORT ENG (12).
    - 2 Open LO-14, PRE-LUBE/PURIFIER SUCT (14).
    - 3 Open LO-24, SUMP SUPPLY/PURIFIER RTN PORT ENG (6).
    - 4 Ensure LO-16, RDCN GEAR SUCT-PORT (4) is closed.
  - (e) Open LO-6, LO PURIFIER DISCH (31).
- c. Start L.O. Purifier

- (1) On L.O. Purifier TYPE-I Motor Switch (FIGURE 2-258) release LOCK (3), press START pushbutton (1).
- (2) Wait 5 minutes for bowl inside purifier to gain speed.
- (3) Slowly open LO-11, PURIFIER SUCTION (32, FIGURE 2-259) until oil is visible in sight glass on top of purifier.
- (4) Check the output by opening the top inspection cover. Close top inspection cover.
- (5) Slowly open LO-11, PURIFIER SUCTION (32) until glass bowl is approximately 1/2 full.
- (6) Allow L.O. Purifier to purify oil for 4 hours per engine.

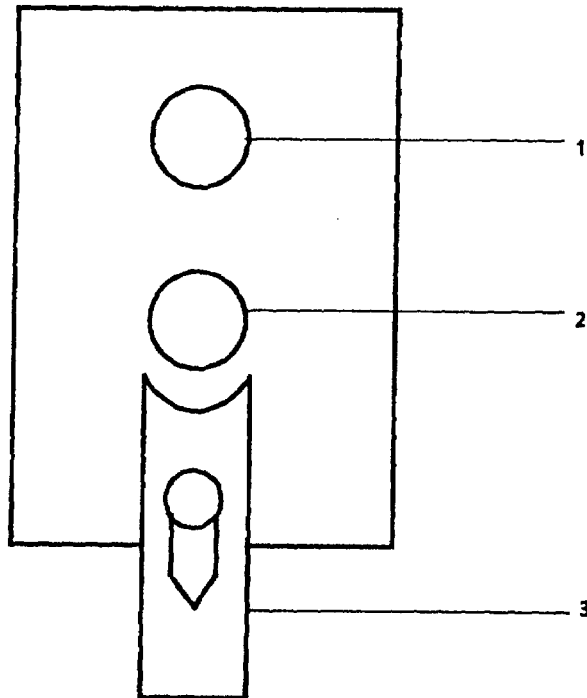

- LEGEND**  
1. START  
2. STOP  
3. LOCK

FIGURE 2-258. TYPE-I Motor Switch.

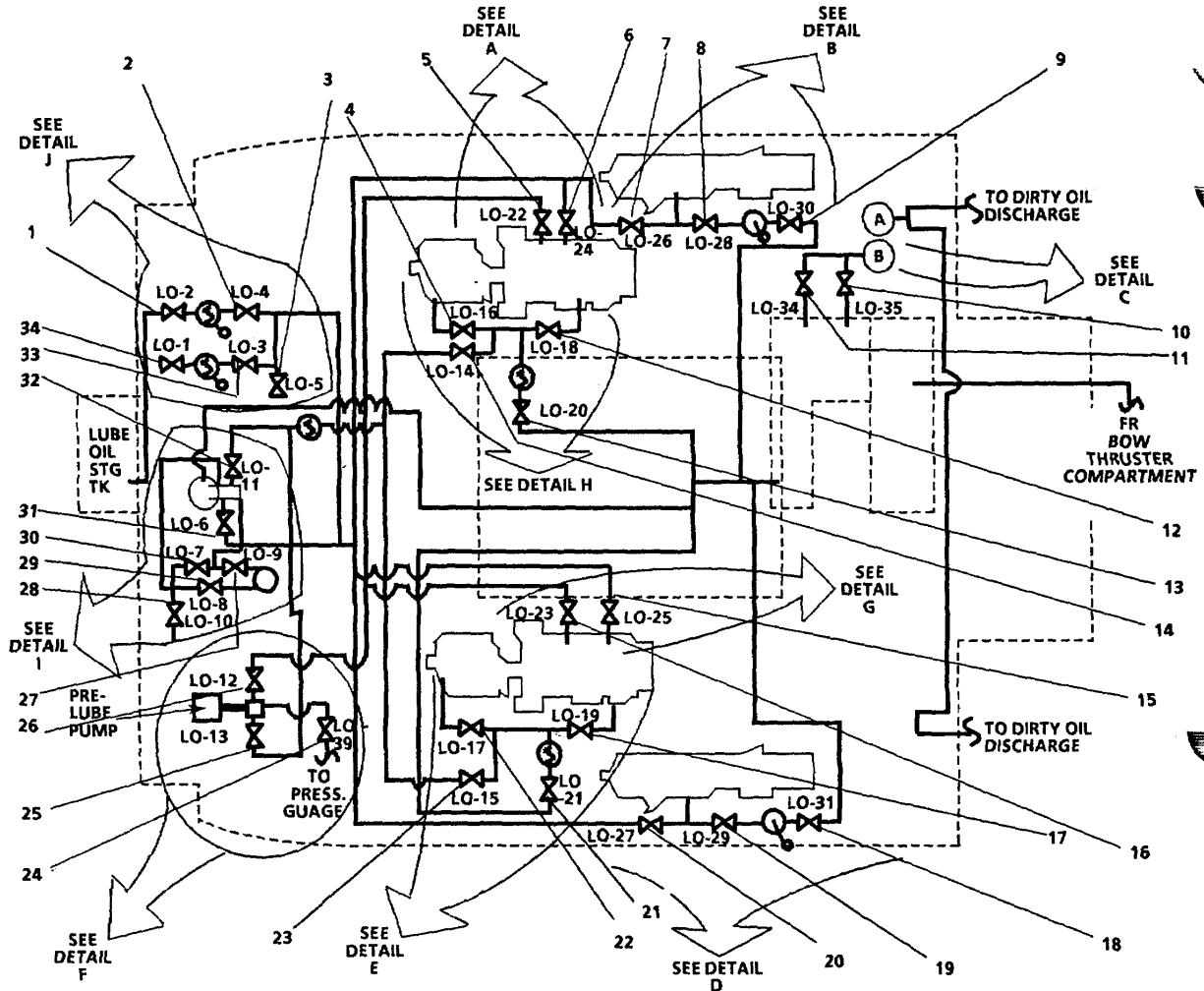

**LEGEND**

- |    |  |    |                               |
|----|--|----|-------------------------------|
| 1  | LO-2, STORAGE TK SUPPLY                  | 21 | LO-21, MN ENG SUMP DISCH      |
| 2  | LO-4, HAND PUMP NO. 2 DISCH              | 22 | LO-17, RDCN GEAR SUCT-STBD    |
| 3  | LO-5, HAND SUPPLY                        | 23 | LO-15, PRE-LUBE PURIFIER SUCT |
| 4  | LO-16, RDCN GEAR SUCT-PORT               | 24 | LO-39, PRESSURE GAGE ISLN     |
| 5  | LO-22, PRE-LUBE RETURN-PORT ENG          | 25 | LO-13, PRE-LUBE PUMP SUCTION  |
| 6  | LO-24, SUMP SUPPLY/PURIFIER RTN-PORT ENG | 26 | LO-12, PRE-LUBE PUMP DISCH    |
| 7  | LO-26, SUMP SUPPLY                       | 27 | LO-9, PRE-HEATER SUPPLY       |
| 8  | LO-28, SUMP SUCT-SSDG                    | 28 | LO-10, PRE-HEATER VENT        |
| 9  | LO-30, SUMP DISCH-SSDG                   | 29 | LO-8, PRE-HEATER OUTLET       |
| 10 | LO-35, SLUDGE TK SUCT                    | 30 | LO-7, PRE-HEATER BY-PASS      |
| 11 | LO-34, DIRTY OIL TK SUCT                 | 31 | LO-6, LO PURIFIER DISCH       |
| 12 | LO-18-SUMP SUCT-PORT ENG                 | 32 | LO-11, PURIFIER SUCTION       |
| 13 | LO-20, MN ENG SUMP DISCH                 | 33 | LO-3, HAND PUMP NO. 1 DISCH   |
| 14 | LO-14, PRE-LUBE PURIFIER SUCT            | 34 | LO-1, STORAGE TK SUPPLY       |
| 15 | LO-25, SUMP SUPPLY/PURIFIER RTN-STBD ENG | 35 | LO-33, SUMP DISCH-BOW ENG     |
| 16 | LO-23, PRE-LUBE RETURN-STBD ENG          | 36 | HAND SUPPLY                   |
| 17 | LO-19, SUMP SUCT-STBD ENG                | 37 | LO-32, SUMP SUCT-BOW ENG      |
| 18 | LO-31, SUMP DISCH-SSDG                   | 38 | LO-37, DIRTY OIL PUMP DISCH   |
| 19 | LO-29, SUMP SUCT-SSDG                    | 39 | LO-36, DIRTY OIL PUMP SUCT    |
| 20 | LO-27, SUMP SUPPLY                       |    |                               |

FIGURE 2-259. Lube Oil Transfer and Purification Piping System (Sheet 1 of 8).

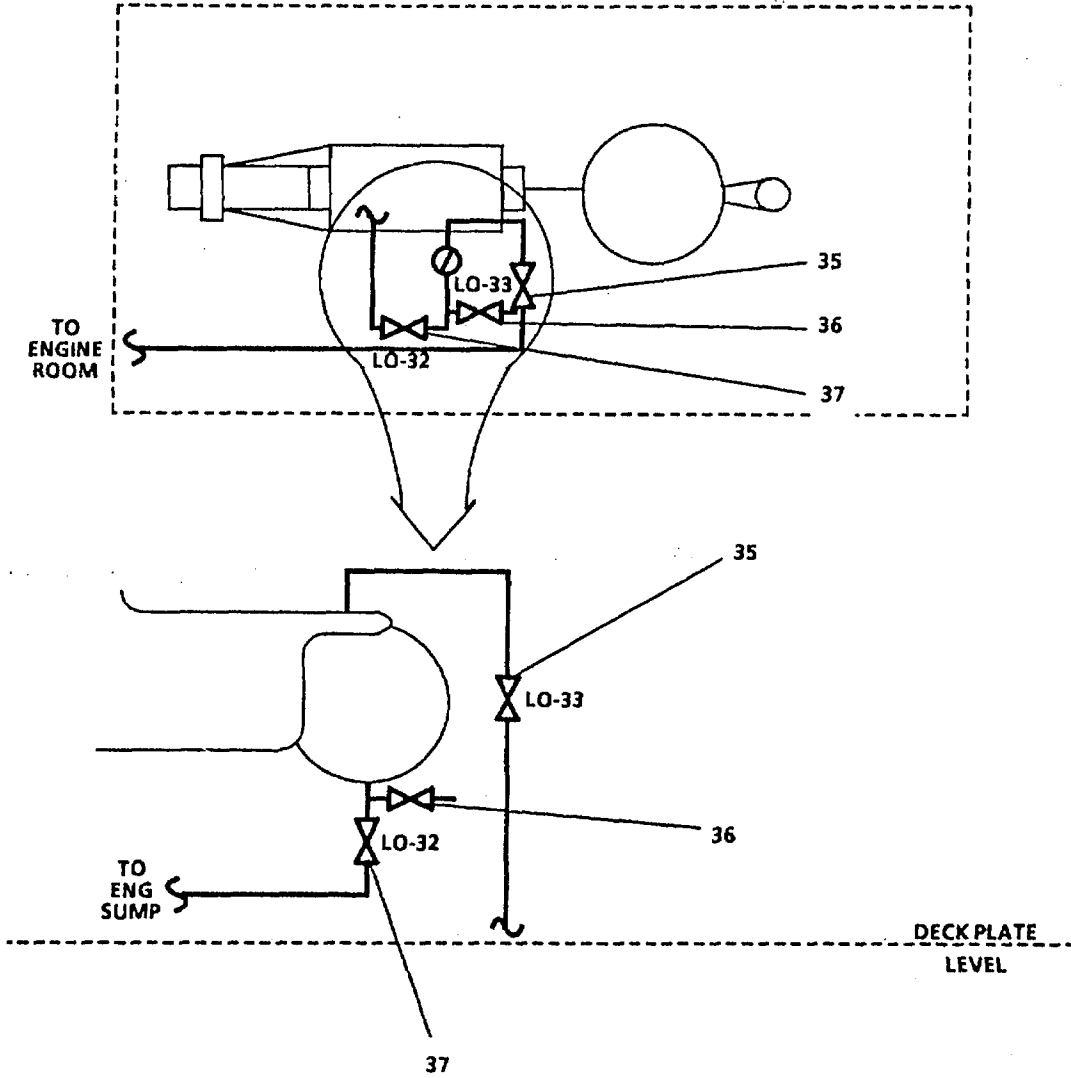
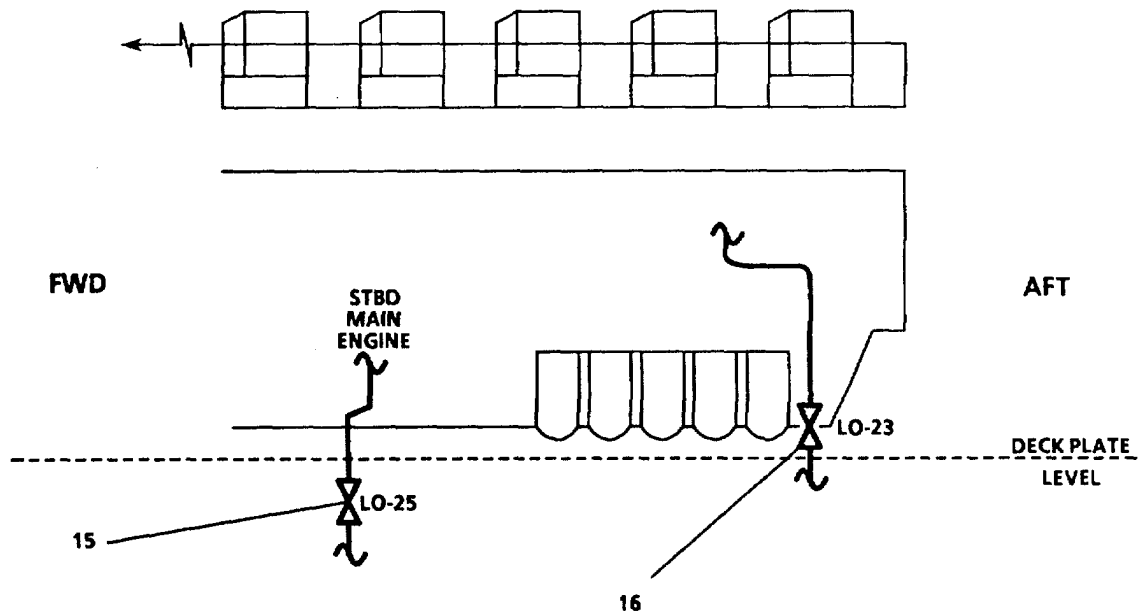

FIGURE 2-259. Lube Oil Transfer and Purification Piping System (Sheet 2 of 8).

DETAIL G



DETAIL H

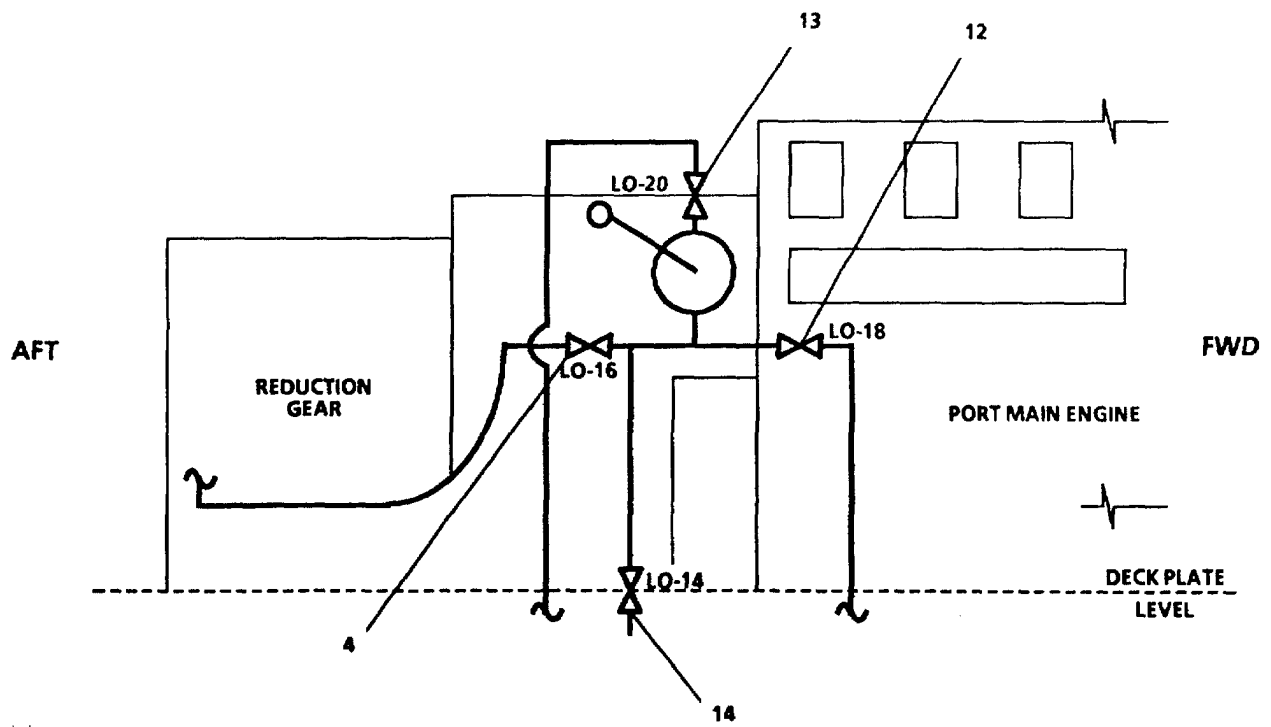

FIGURE 2-259. Lube Oil Transfer and Purification Piping System (Sheet 3 of 8).

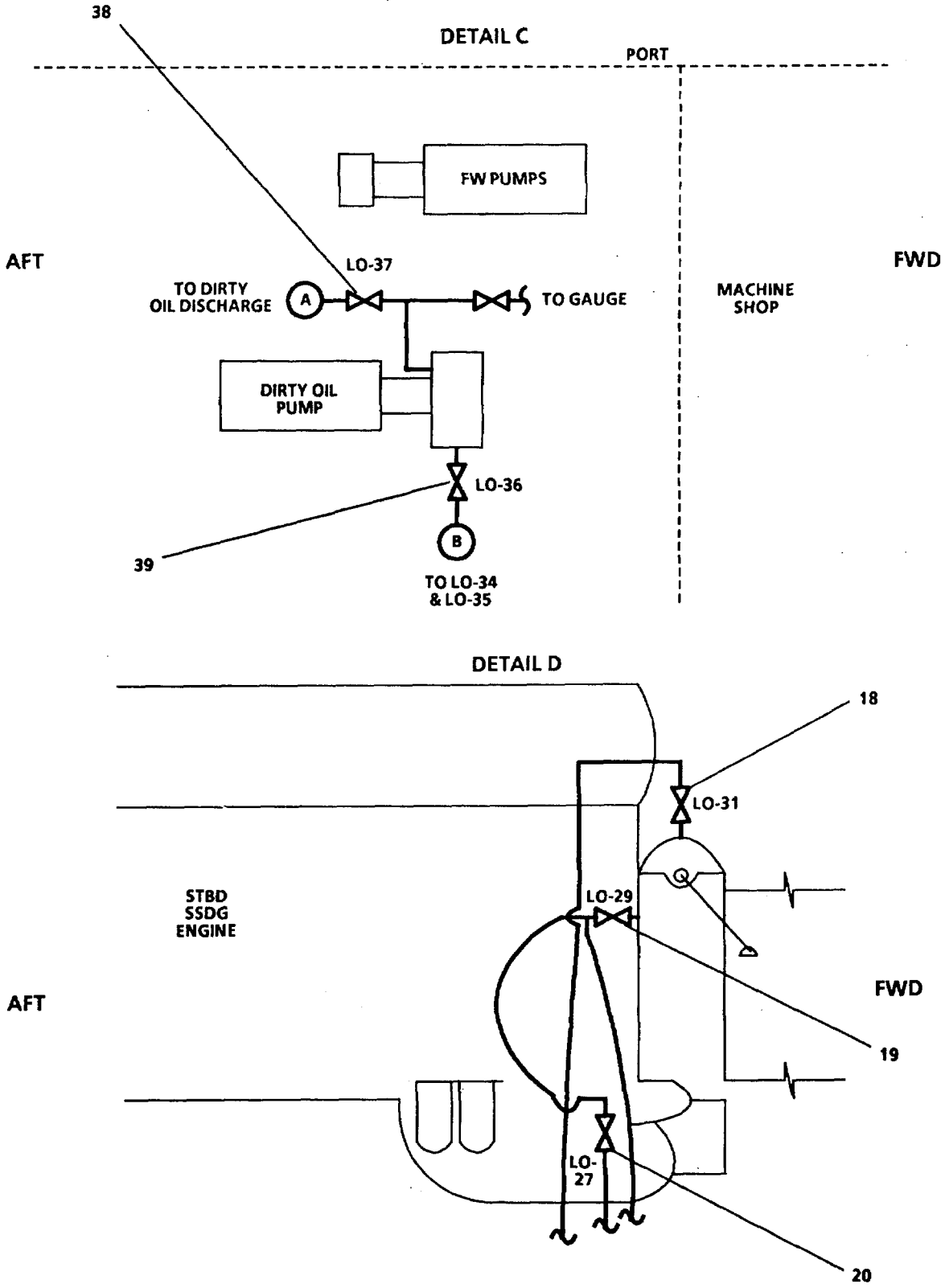

FIGURE 2-259. Lube Oil Transfer and Purification Piping System (Sheet 4 of 8).



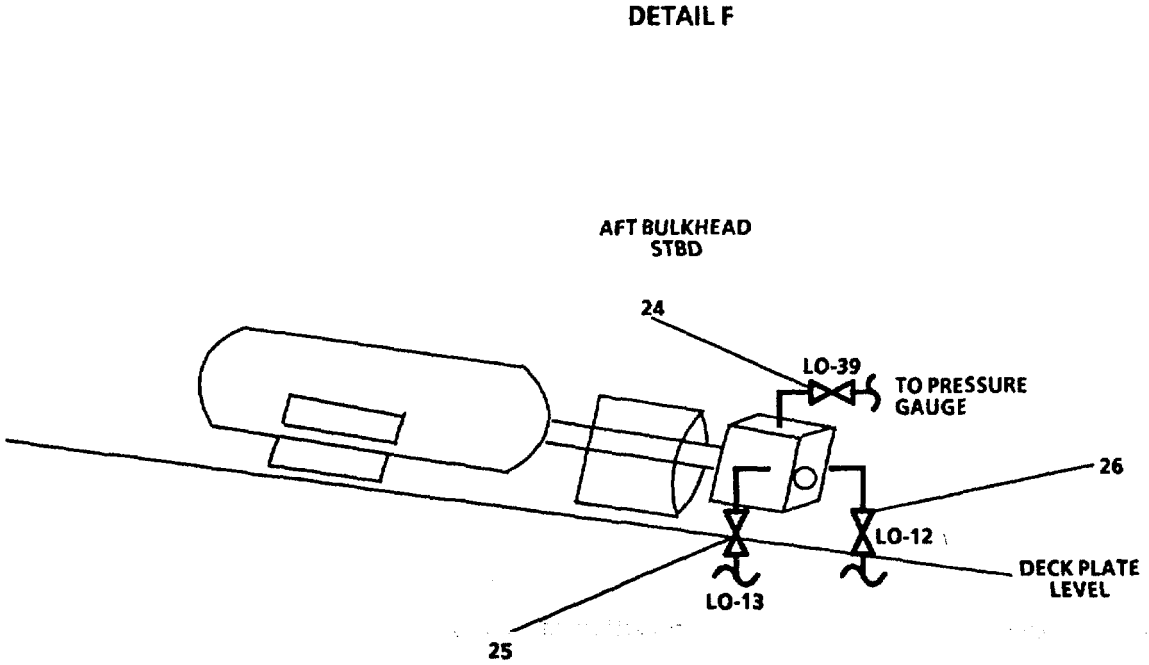
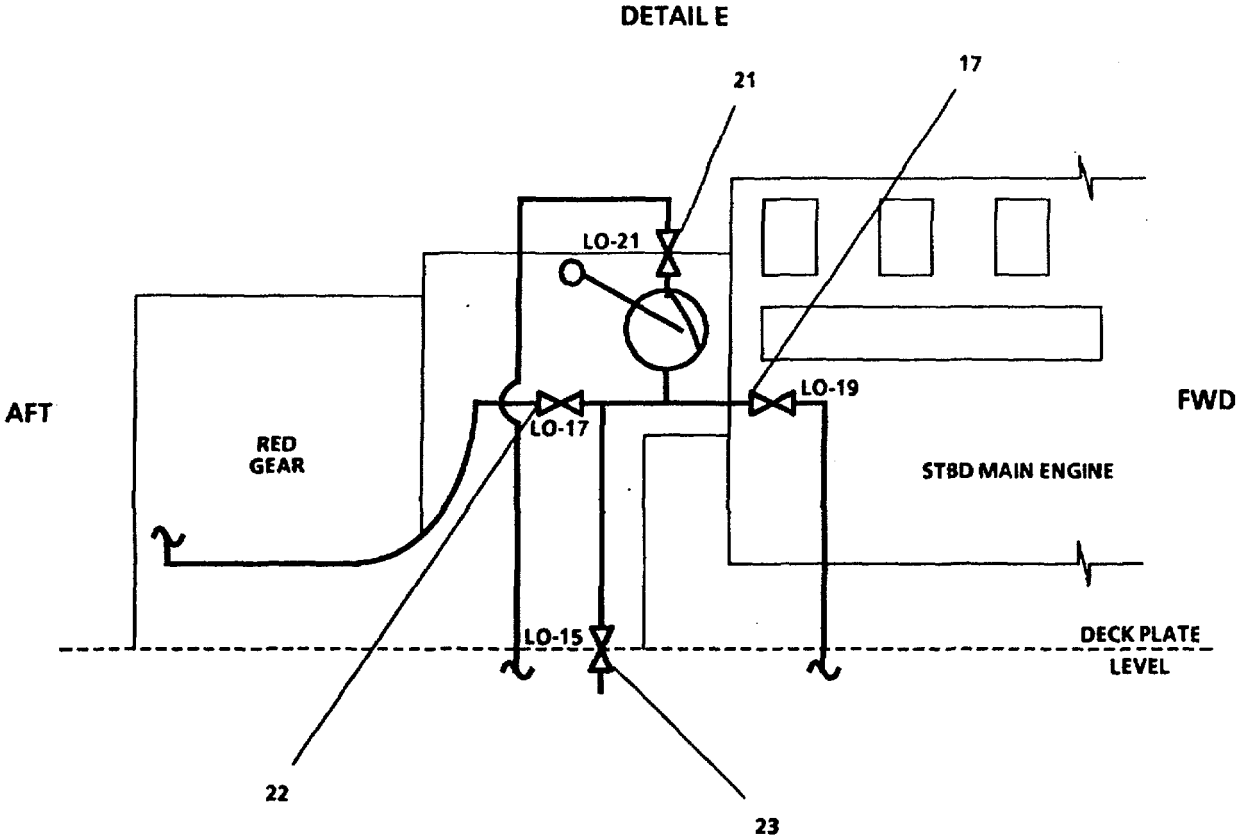
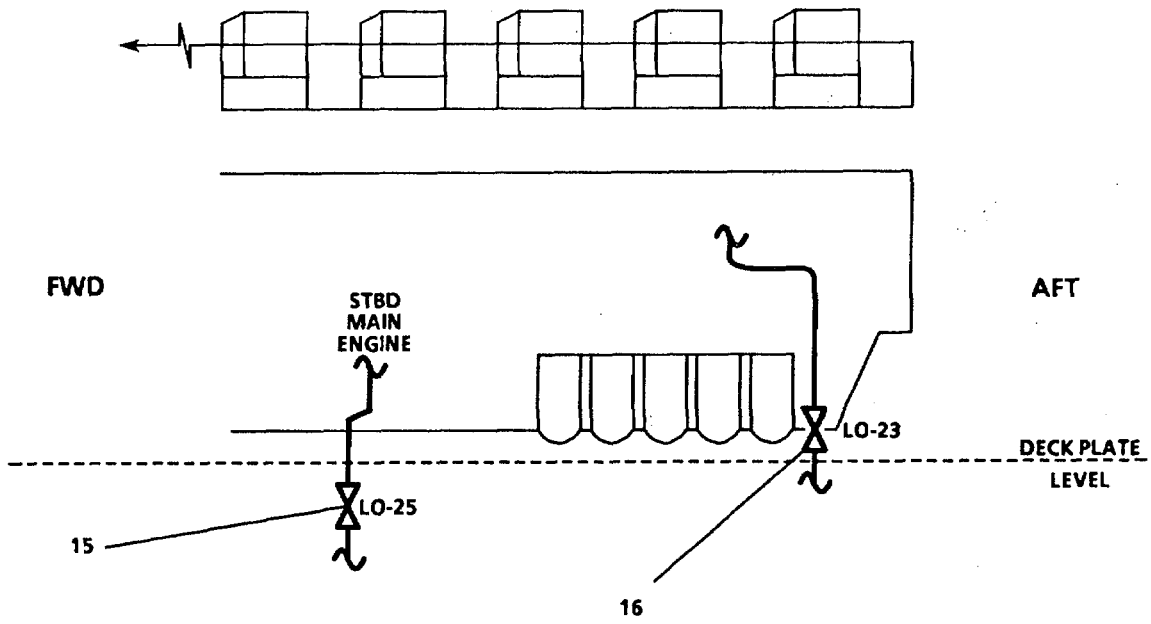

FIGURE 2-259. Lube Oil Transfer and Purification Piping System (Sheet 5 of 8).

DETAIL G



DETAIL H

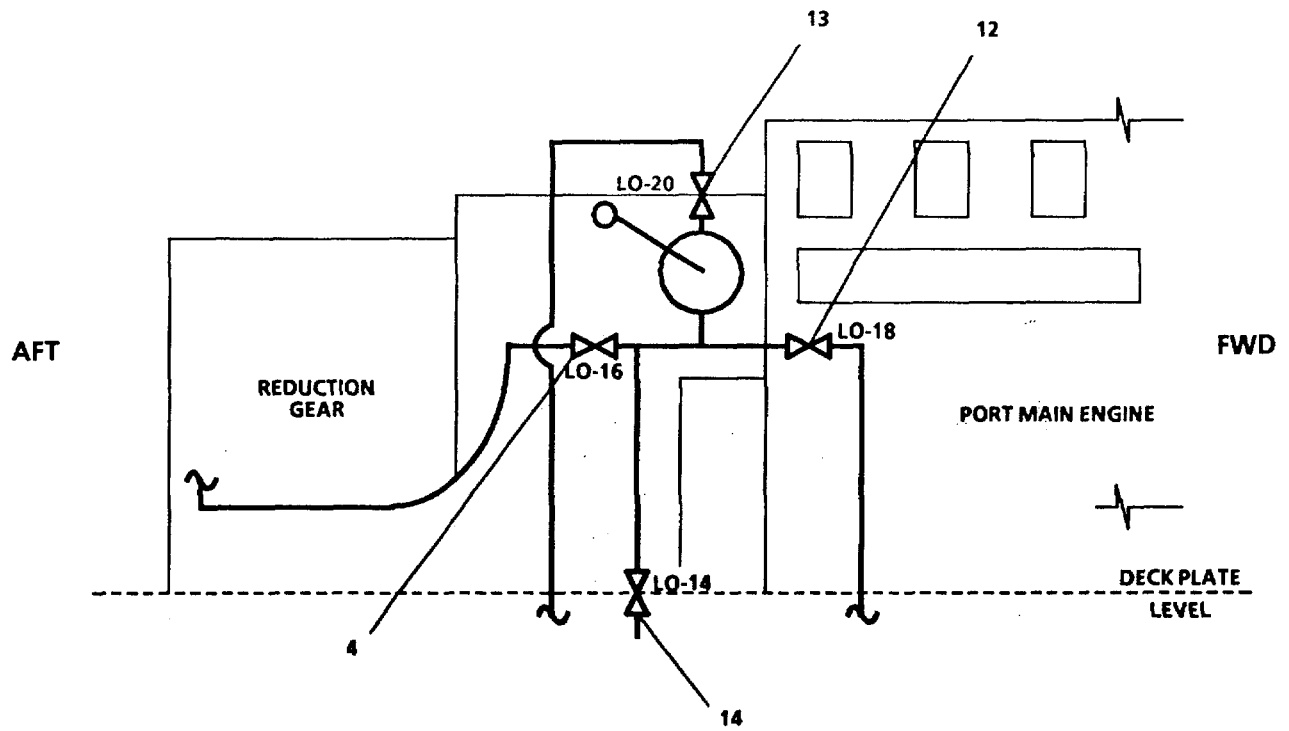

FIGURE 2-259. Lube Oil Transfer and Purification Piping System (Sheet 6 of 8).

DETAIL I  
LOOKING AFT

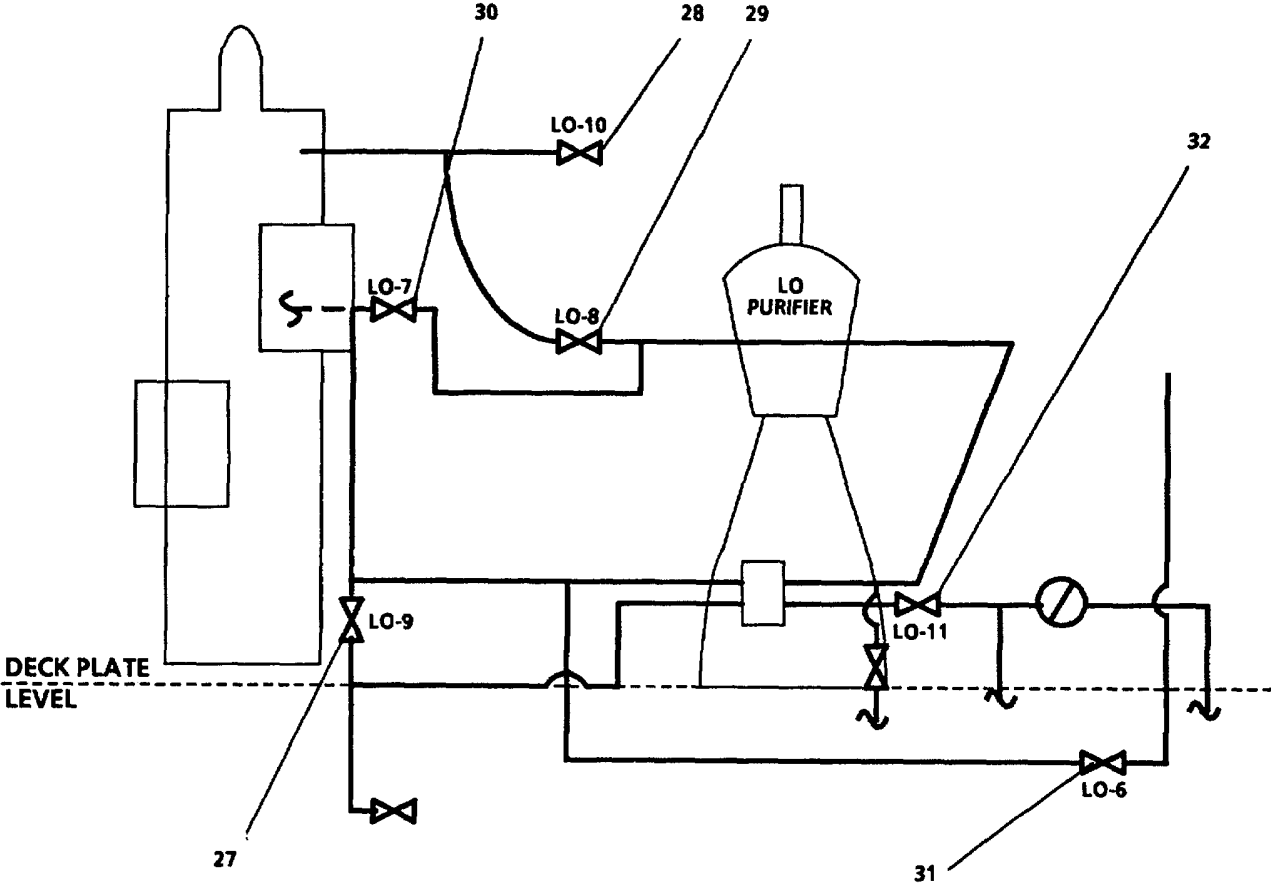
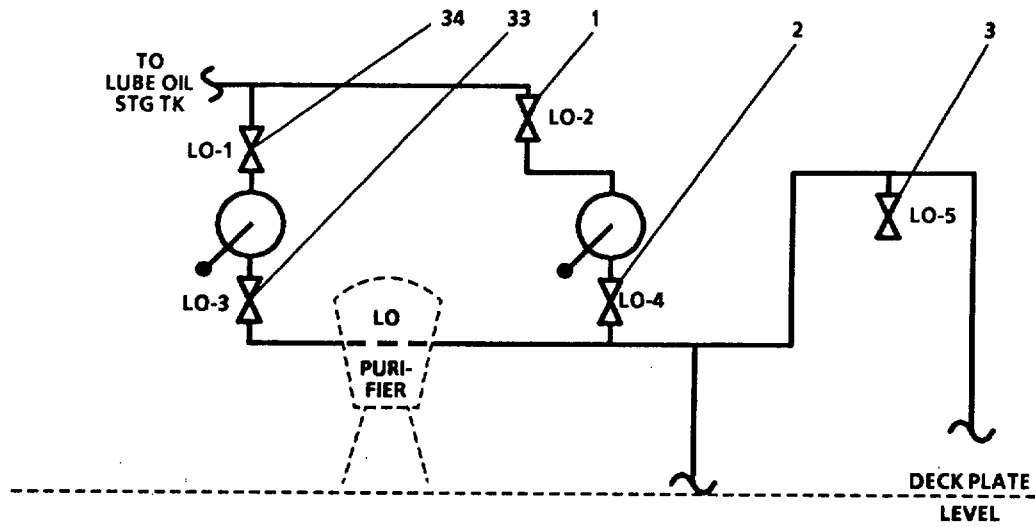

FIGURE 2-259. Lube Oil Transfer and Purification Piping System (Sheet 7 of 8).

DETAIL J



LEGEND

- |    |  |    |                               |
|----|--|----|-------------------------------|
| 1  | LO-2, STORAGE TK SUPPLY                  | 21 | LO-21, MN ENG SUMP DISCH      |
| 2  | LO-4, HAND PUMP NO. 2 DISCH              | 22 | LO-17, RDCN GEAR SUCT-STBD    |
| 3  | LO-5, HAND SUPPLY                        | 23 | LO-15, PRE-LUBE PURIFIER SUCT |
| 4  | LO-16, RDCN GEAR SUCT-PORT               | 24 | LO-39, PRESSURE GAGE ISLN     |
| 5  | LO-22, PRE-LUBE RETURN-PORT ENG          | 25 | LO-13, PRE-LUBE PUMP SUCTION  |
| 6  | LO-24, SUMP SUPPLY/PURIFIER RTN-PORT ENG | 26 | LO-12, PRE-LUBE PUMP DISCH    |
| 7  | LO-26, SUMP SUPPLY                       | 27 | LO-9, PRE-HEATER SUPPLY       |
| 8  | LO-28, SUMP SUCT-SSDG                    | 28 | LO-10, PRE-HEATER VENT        |
| 9  | LO-30, SUMP DISCH-SSDG                   | 29 | LO-8, PRE-HEATER OUTLET       |
| 10 | LO-35, SLUDGE TK SUCT                    | 30 | LO-7, PRE-HEATER BY-PASS      |
| 11 | LO-34, DIRTY OIL TK SUCT                 | 31 | LO-6, LO PURIFIER DISCH       |
| 12 | LO-18-SUMP SUCT-PORT ENG                 | 32 | LO-11, PURIFIER SUCTION       |
| 13 | LO-20, MN ENG SUMP DISCH                 | 33 | LO-3, HAND PUMP NO. 1 DISCH   |
| 14 | LO-14, PRE-LUBE PURIFIER SUCT            | 34 | LO-1, STORAGE TK SUPPLY       |
| 15 | LO-25, SUMP SUPPLY/PURIFIER RTN-STBD ENG | 35 | LO-33, SUMP DISCH-BOW ENG     |
| 16 | LO-23, PRE-LUBE RETURN-STBD ENG          | 36 | HAND SUPPLY                   |
| 17 | LO-19, SUMP SUCT-STBD ENG                | 37 | LO-32, SUMP SUCT-BOW ENG      |
| 18 | LO-31, SUMP DISCH-SSDG                   | 38 | LO-37, DIRTY OIL PUMP DISCH   |
| 19 | LO-29, SUMP SUCT-SSDG                    | 39 | LO-36, DIRTY OIL PUMP SUCT    |
| 20 | LO-27, SUMP SUPPLY                       |    |                               |

FIGURE 2-259. Lube Oil Transfer and Purification Piping System (Sheet 8 of 8).

## d. L.O. Purifier and L.O. Purifier Preheater Shutdown.

- (1) On Lube Oil Heater TYPE-I Motor Switch (FIGURE 2-258) press STOP pushbutton (2) and set LOCK (3) by sliding LOCK (3) upward.
- (2) Close LO-11, PURIFIER SUCTION (32, FIGURE 2-259).
- (3) Wait 1 minute.
- (4) On L.O. Purifier TYPE-I Motor Switch (FIGURE 2-258) press STOP pushbutton (2) and set LOCK (3) by sliding LOCK (3) upward.
- (5) Close all valves in the Lube Oil Purification and Transfer piping system (FIGURE 2-259).
- (6) On Auxiliary Machinery Motor Control Center (FIGURE 2-257) set L.O. PURIFIER circuit breaker (1) and L.O. PURIFIER HEATER circuit breaker (2) to OFF position.

**2-54. Rigging the LCU to be Towed.****NOTE**

- Preparations for being towed should be started as soon as possible after casualty which disabled the LCU requiring a tow.
  - Most vessels carry aboard an emergency tow wire commonly known as an "insurance cable." This insurance cable is employed for taking a disabled vessel into tow.
  - The specific method and length of tow hawsers used for towing will depend on several factors such as protected waters or open waters, weather conditions, distance to be towed and type of equipment on board the vessel.
  - The LCU towing bridle assembly will be used for rigging to be towed in protected waters. The most forward bitts and chocks on the forecastle are used for rigging the LCU for tow.
  - The tow bridle can be assembled on either the starboard or port side. Instructions are given for the starboard side.
- (1) Place the FISHPLATE (7, FIGURE 2-260) on the starboard forecastle between the CHOCK (6) and BITT (9).
  - (2) Place the eye of the BRIDLE LEG (5) on the starboard side on the forward post of the BITT (9). Lead the bite around the outboard side of the aft post of the BITT (9), through the CHOCK (6) and back to the starboard aft SHACKLE (8) on the FISHPLATE (7).

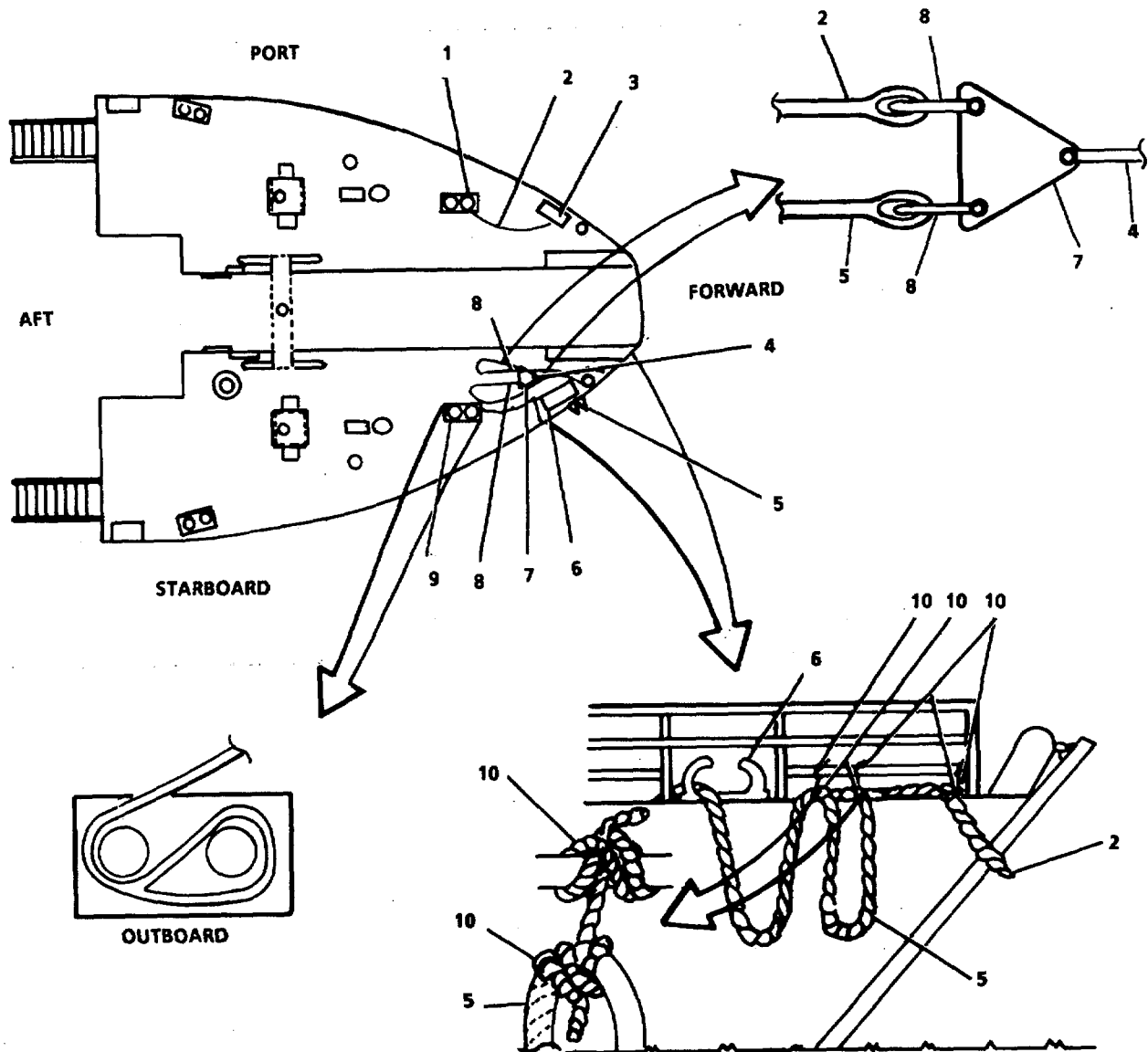

**LEGEND**

- |                              |                    |
|------------------------------|--------------------|
| 1. BITT-PORT                 | 6. CHOCK-STARBOARD |
| 2. BRIDLE LEG-PORT           | 7. FISHPLATE       |
| 3. CHOCK-PORT                | 8. SHACKLE-LCU END |
| 4. SHACKLE-RESCUE VESSEL END | 9. BITT-STARBOARD  |
| 5. BRIDLE LEG-STARBOARD      | 10. STOPPER HITCH  |

FIGURE 2-260. Protected Water Tow Rig.

**CAUTION**

The slack in the bridle leg outboard of the forecastle must be secured with stopper hitches to keep it clear of the anchor to avoid fouling the bridle leg when setting the tow.

- (3) Place STOPPER HITCHES (10) in the bite of the BRIDLE LEG (5) to keep it clear of the water and clear of the anchor.

**WARNING**

Shackles can have a screw type pin, bolt with a nut and pin with a wedge and forelock key. The screw type must be moused to prevent it backing out. The bolt and nut type pin usually have a cotter key to prevent the nut backing off; however, the nut can shear the cotter key so it must also be moused. If the tow is over a long distance the nut and bolt must be tack welded to the shackle. The head of the pin with a wedge and forelock key must be tack welded to the shackle. If the shackle releases from the fishplate, the bridle leg could whip across the forecastle deck causing personal injury or death.

- (4) Connect the BRIDLE LEG (5) to the FISHPLATE (7) with a SHACKLE (8) and secure the shackle pin.
- (5) Place the eye of the BRIDLE LEG (2) on the port side on the forward post of the BITT (1). Lead the bite around the outboard side of the aft post of the BITT (1), through the CHOCK (3) and across the outboard side of the ramp to the starboard side forecastle, to the port aft SHACKLE (8) of the FISHPLATE (7).
- (6) Place a STOPPER HITCH (10) on the BRIDLE LEG (2) and life line where it comes under the life line on the starboard forecastle.
- (7) Connect the BRIDLE LEG (2) to the FISHPLATE (7) with a SHACKLE (8) and secure the shackle pin.

**NOTE**

The rescue vessel will pass a messenger line to haul aboard the tow line. If the bow anchor winch is operational use the gypsy head to haul the tow line aboard. If the bow anchor is not operational the tow line can be hauled aboard by hand or a block and tackle rig.

- (8) Haul tow line aboard and secure with a stopper.
- (9) Position FISHPLATE (7) with the SHACKLE (4) for attaching tow line facing forward and secure with small stuff.

**NOTE**

Chafing gear should be placed a minimum of twelve inch to each side of the point of contact. Chafing gear may be made from canvas, split tubing, wood or other material.

- (10) Place chafing gear on the bridle leg where it contacts metal surfaces.
- (11) Check that the FISHPLATE (7) and the BRIDLE LEGS (2 and 5) will pay out without fouling when the rescue vessel takes a strain on the tow line.
- (12) Connect the tow line to the FISHPLATE (7) with SHACKLE (4).

**WARNING**

When the rescue vessel takes a strain on the tow line the towing bridle assembly may whip up and down. Personnel standing close to the rigging could be seriously injured!

- (13) Prior to the rescue vessel taking a strain on the tow line move all crewmembers off the forecastle.
- (14) Cut all stoppers except the minimum to hold the fishplate on deck.
- (15) Signal to the rescue vessel to go ahead slow and take a strain on the tow line.
- (16) After the towing bridle is payed out check at towing bridle gear for damage and proper ride.
- (17) Set watch to check towing bridle gear every hour until arrival at destination.

**2-55. Firefighting System Operation.****NOTE**

The Bowthruster engine and the emergency fire pump operation are under local operation conditions.

**a. Start Bowthruster Engine**

- (1) Align Bowthruster Fuel Supply (FIGURE 2-261) by opening FO-55, DAY TK SUPPLY TO BOWTHRUSTER ENG (1).
- (2) Align Bowthruster Sea Water Cooling Piping System (FIGURE 2-262) as follows:
  - (a) Open SEA CHEST VENT (7).
  - (b) Open SEA CHEST VENT ISOLATION (3).
  - (c) Open SW-29, SEA CHEST SUCT (2).



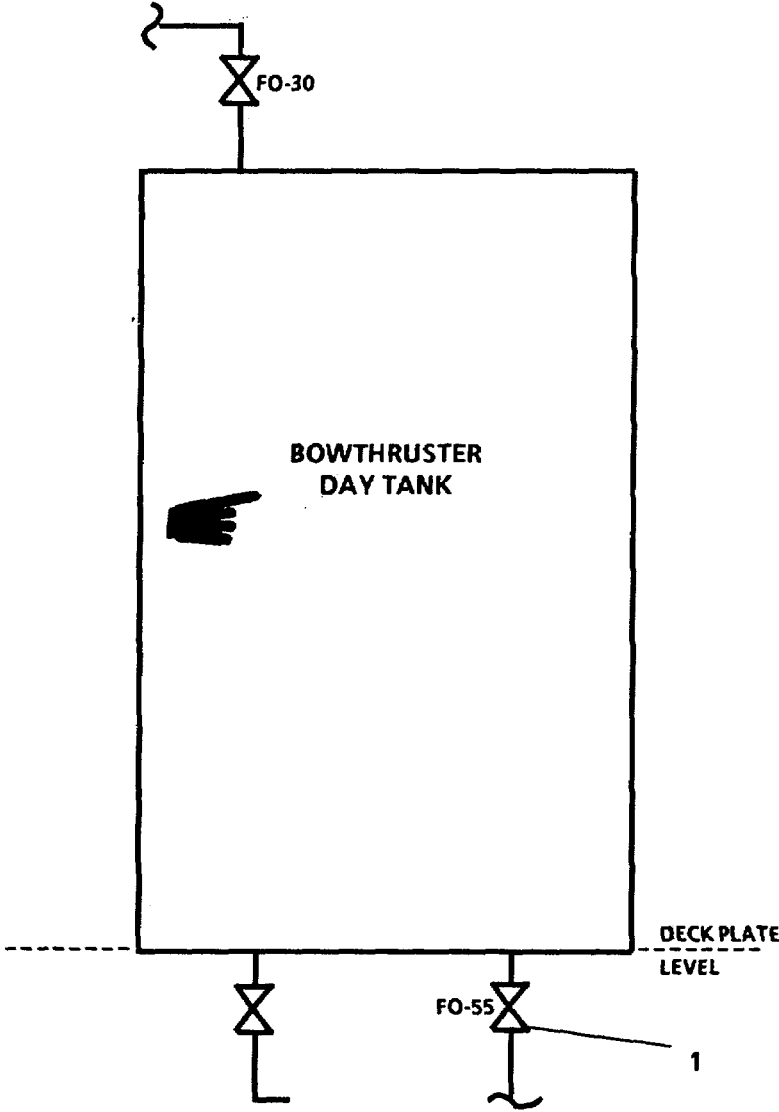

1. FO-55, DAY TK SUPPLY TO BOWTHRUSTER ENG

FIGURE 2-261. Bowthruster Fuel Oil Day Tank.

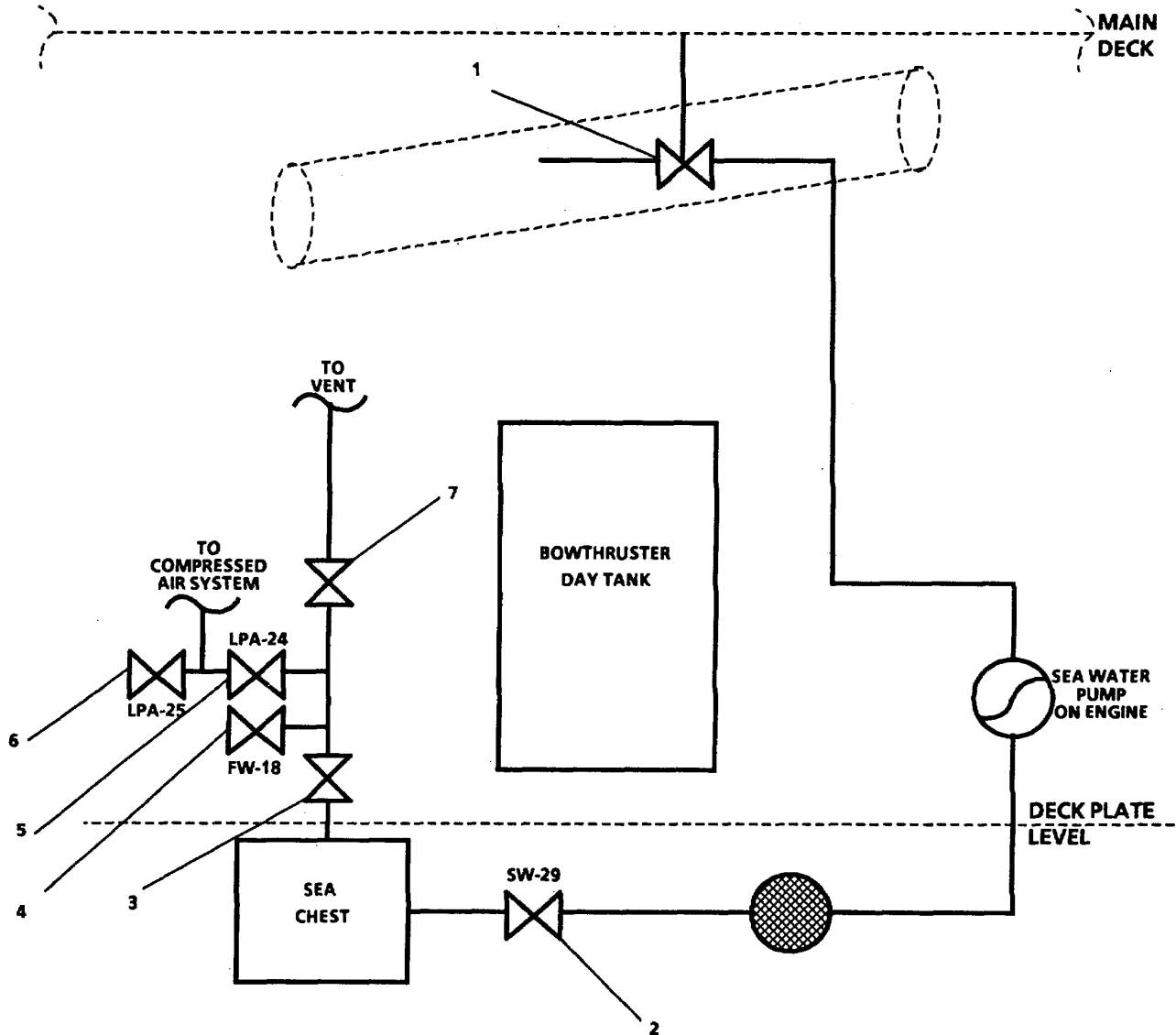

**LEGEND**

- |  |  |
|--|--|
| <ul style="list-style-type: none"> <li>1. SW-30, ENGINE EXHAUST CUTOUT (CONTROLLED FROM MAIN DECK, UNDER PORT FORECASTLE LADDER).</li> <li>2. SW-29, SEA CHEST SUCT</li> <li>3. SEA CHEST VENT ISOLATION</li> <li>4. FW-18, SEA CHEST - HOT FW CONN</li> </ul> | <ul style="list-style-type: none"> <li>5. LPA-24, SEA CHEST BLWDN</li> <li>6. LPA-25, SUPPLY TO SVCE SIR</li> <li>7. SEA CHEST VENT</li> </ul> |
|--|--|

FIGURE 2-262. Bowthruster Sea Water Cooling Piping System.

- (d) Open SW-30, ENG EXHAUST CUTOFF (1) (located on main deck underneath the port forecastle ladder).
- (e) At the Bowthruster Engine Control Panel (FIGURE 2-263), set STARTER CUTOFF SWITCH (4) in the up position. Set START SWITCH (3) in the up position.
- (f) Press PUSH TO CRANK pushbutton (2).

**CAUTION**

If engine fails to start within 30 seconds, release PUSH TO CRANK (1) pushbutton. Wait 2 minutes to allow starter motor to cool before using it again.

- (g) Allow engine to idle for 3 to 5 minutes until ENGINE WATER (5) gauge starts to rise.

**CAUTION**

If ENGINE OIL gauge (6) does not rise to 45 psi within 15 seconds, stop engine or equipment damage could result. Notify unit maintenance.

**NOTE**

All Diesel Engines, except Main Engines, on the LCU have an Automatic Low Oil Pressure Shutdown System. This system will activate at a low oil pressure condition and shut engine down.

b. Emergency Fire Pump Operation.

- (1) Open SEA CHEST VENT (7, FIGURE 2-262).
- (2) Open SEA CHEST VENT ISOLATION (3).
- (3) Open FM-19, EMER FIREPUMP SEA CHEST ISLN (30, FIGURE 2-264).
- (4) Open FM-20, EMER FIREPUMP DISCH (31).
- (5) CLOSE FM-15, NO. 2 FIRE PUMP DISCH (15).
- (6) CLOSE FM-14, NO. 1 FIRE PUMP DISCH (16).
- (7) CLOSE FM-13, FIREMAIN & BALLAST CROSS CONN (29).
- (8) At Engine Room Console (FIGURE 2-265), set CONTROL AIR SELECTOR (1) to the engine room position.
- (9) Start Emergency Fire Pump by shifting clutch arm aft.
- (10) Control engine speed with throttle linkage.

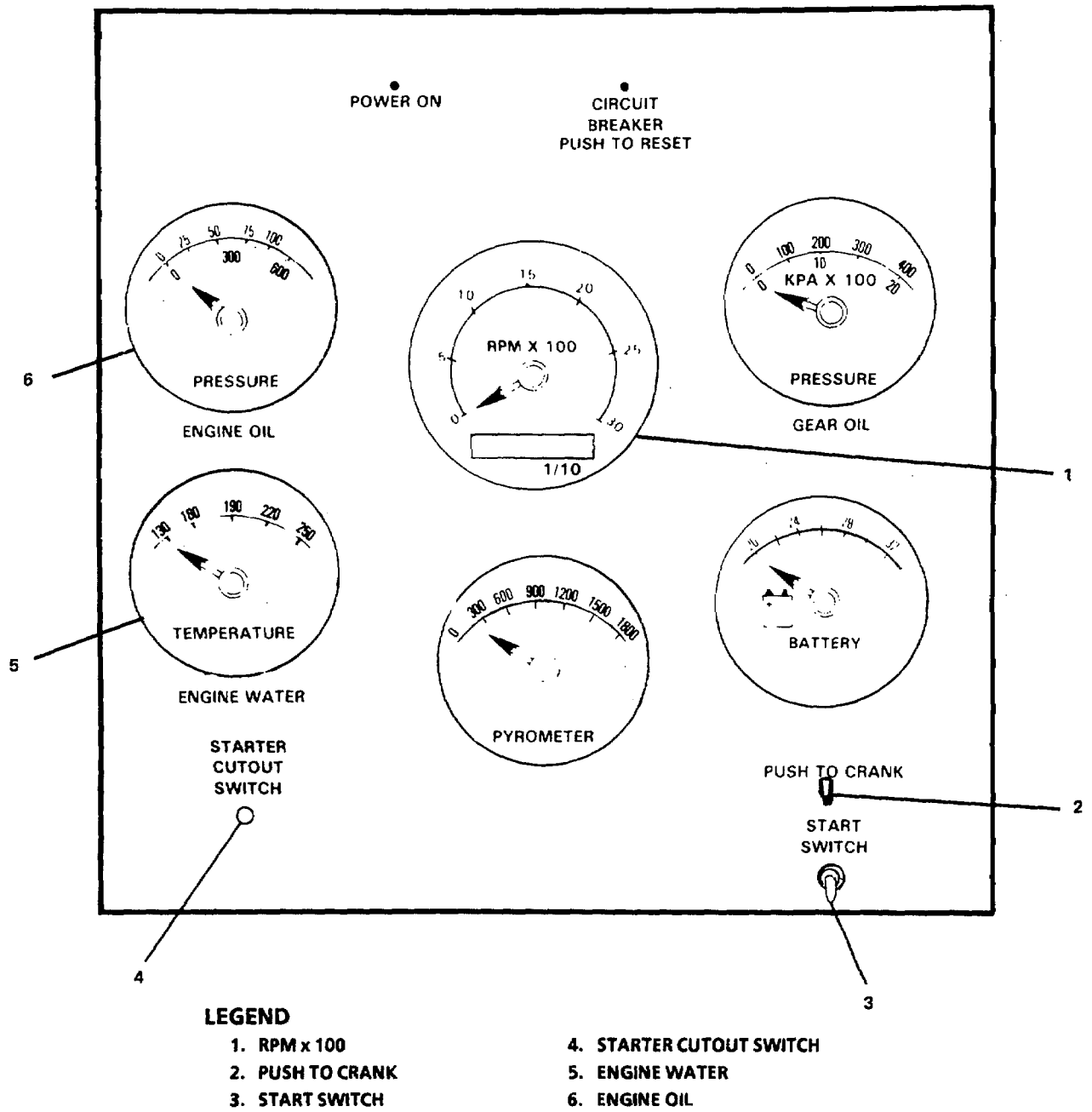

FIGURE 2-263. Bowthruster Engine Control Panel.

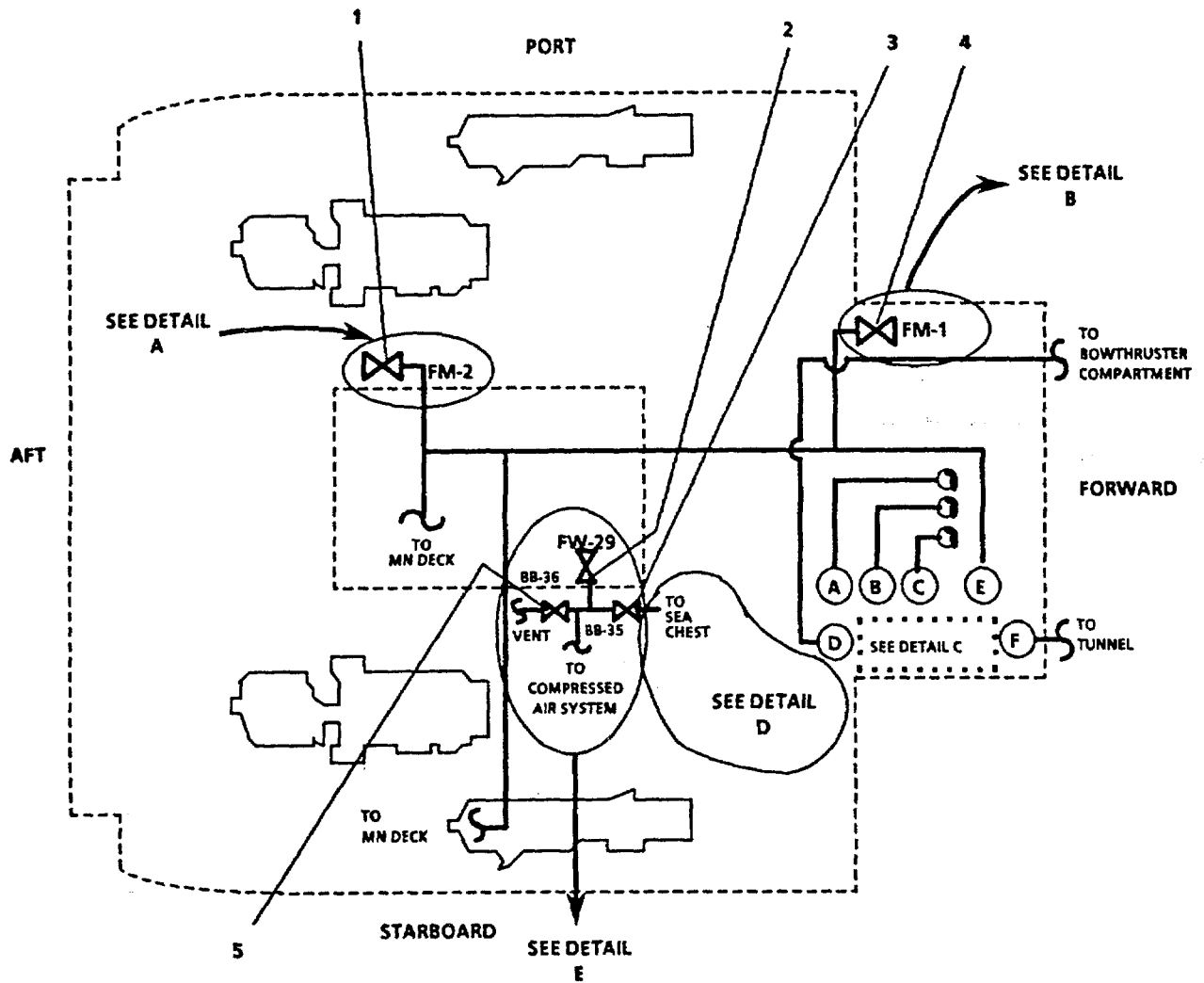

FIGURE 2-264. Fire Main and Foam Piping System (Sheet 1 of 12).

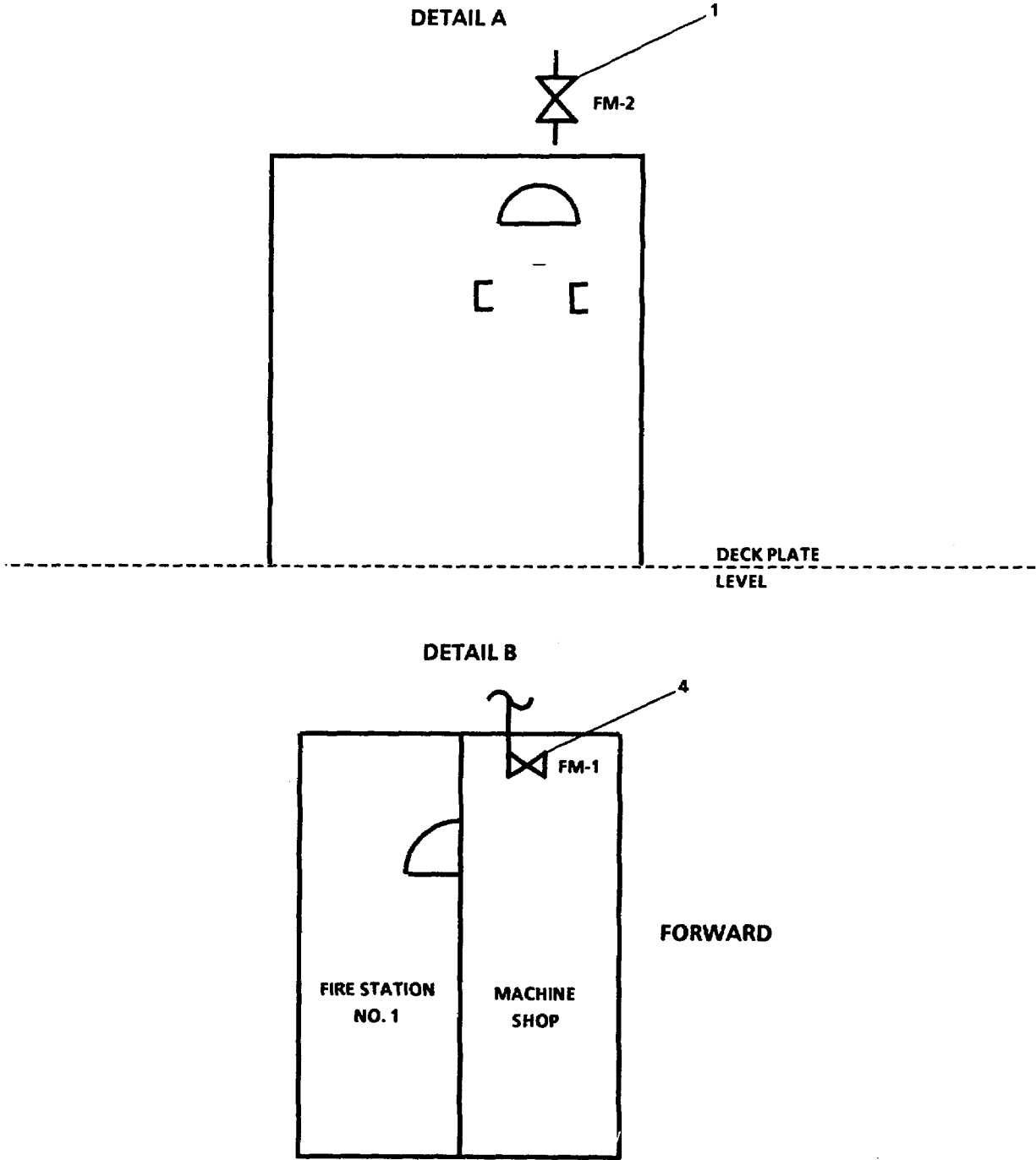
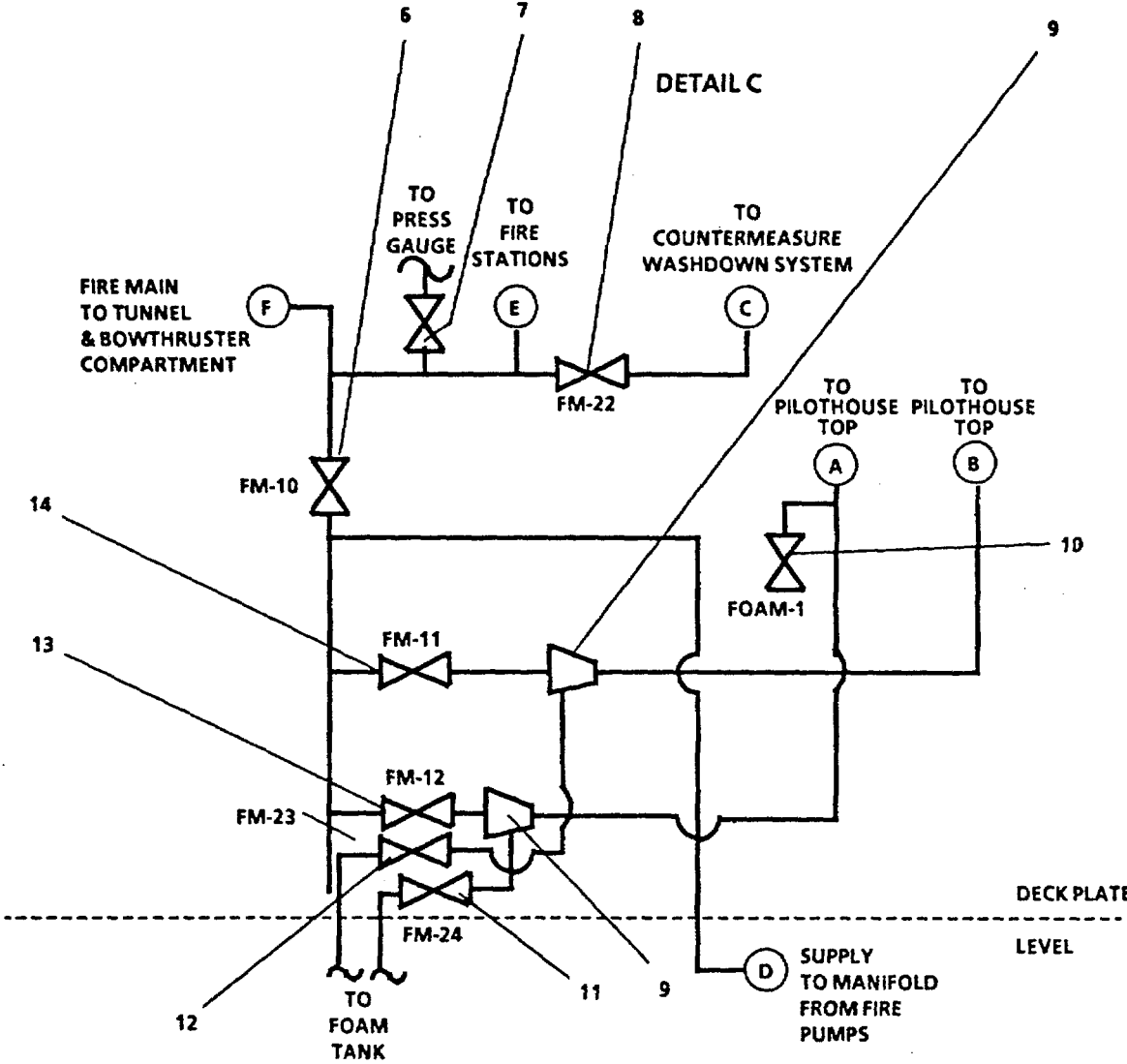

FIGURE 2-264. Fire Main and Foam Piping System (Sheet 2 of 12).



LOOKING STARBOARD AT PORT BULKHEAD OF STOREROOM

FIGURE 2-264. Fire Main and Foam Piping System (Sheet 3 of 12).

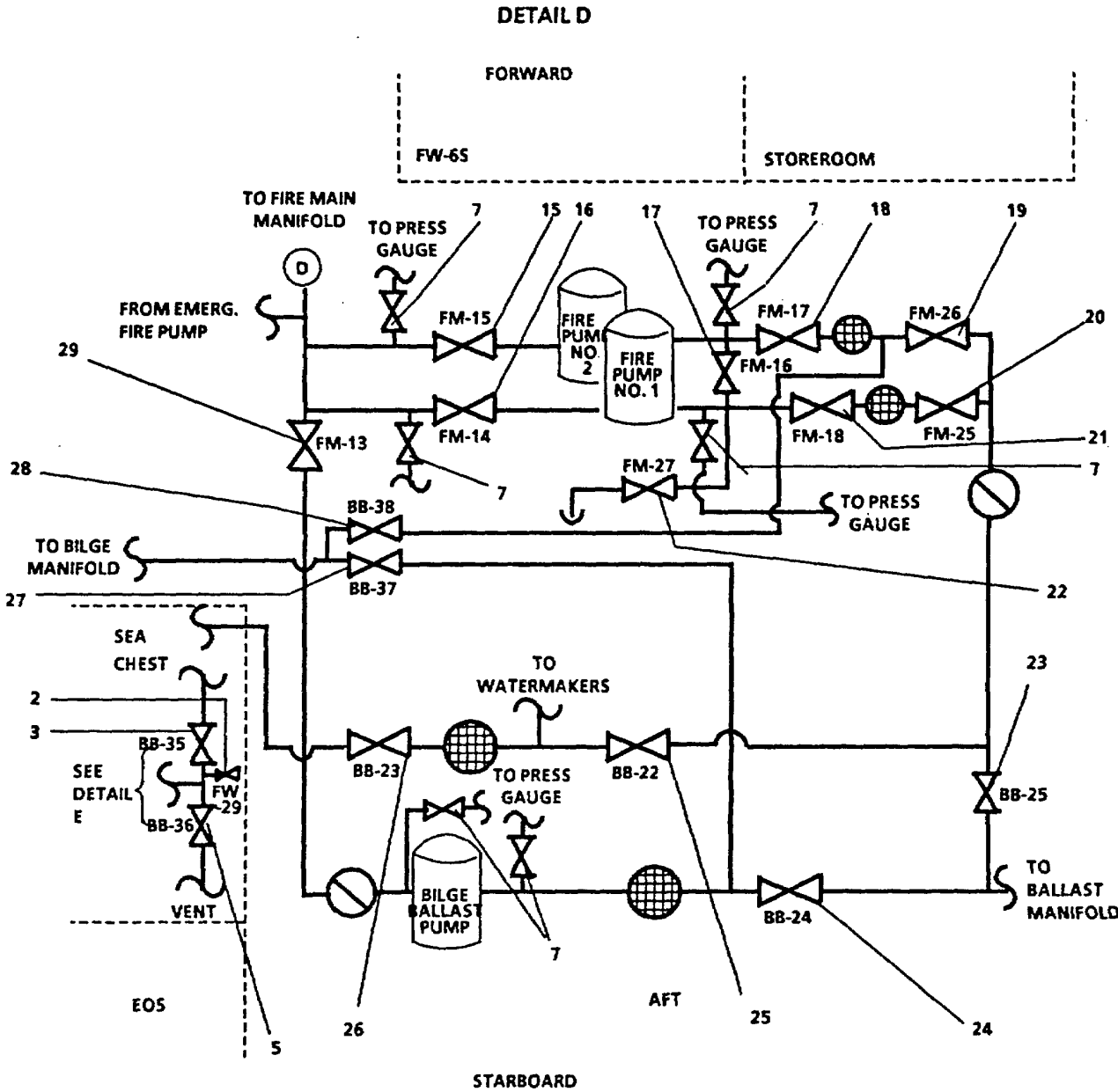

FIGURE 2-264. Fire Main and Foam Piping System (Sheet 4 of 12).



DETAIL E

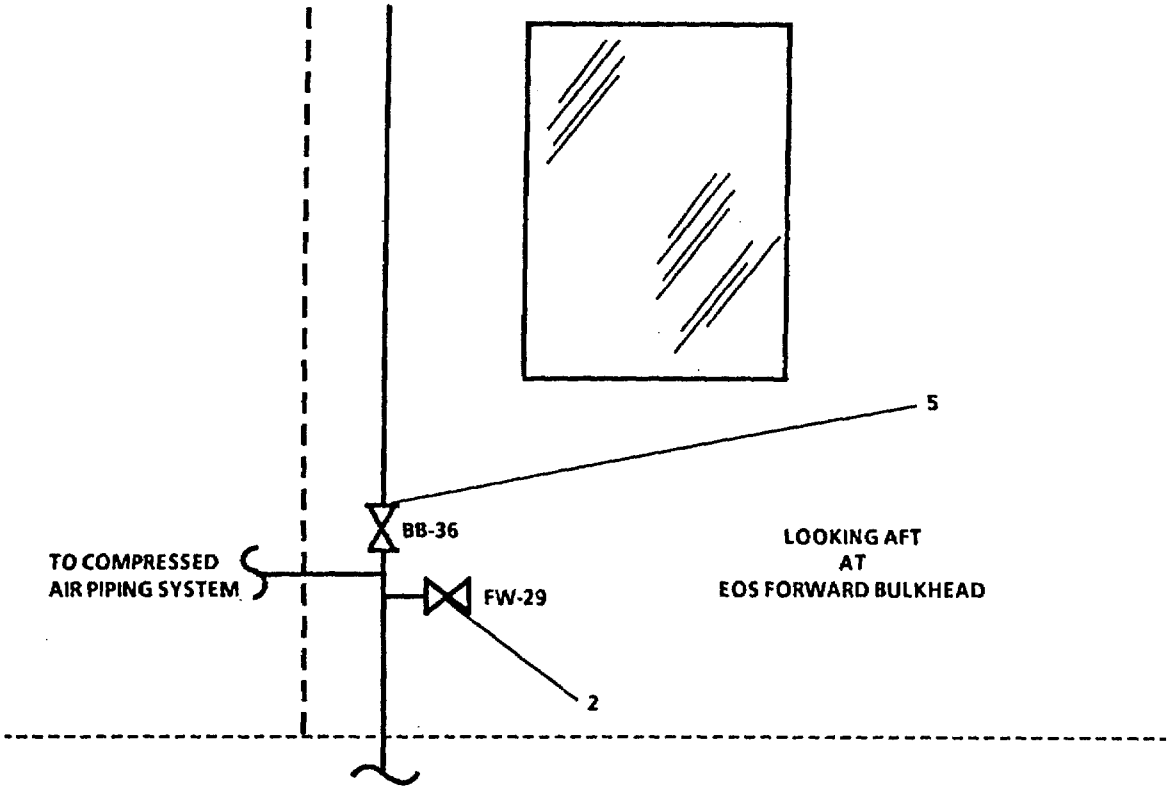

FIGURE 2-264. Fire Main and Foam Piping System (Sheet 5 of 12).

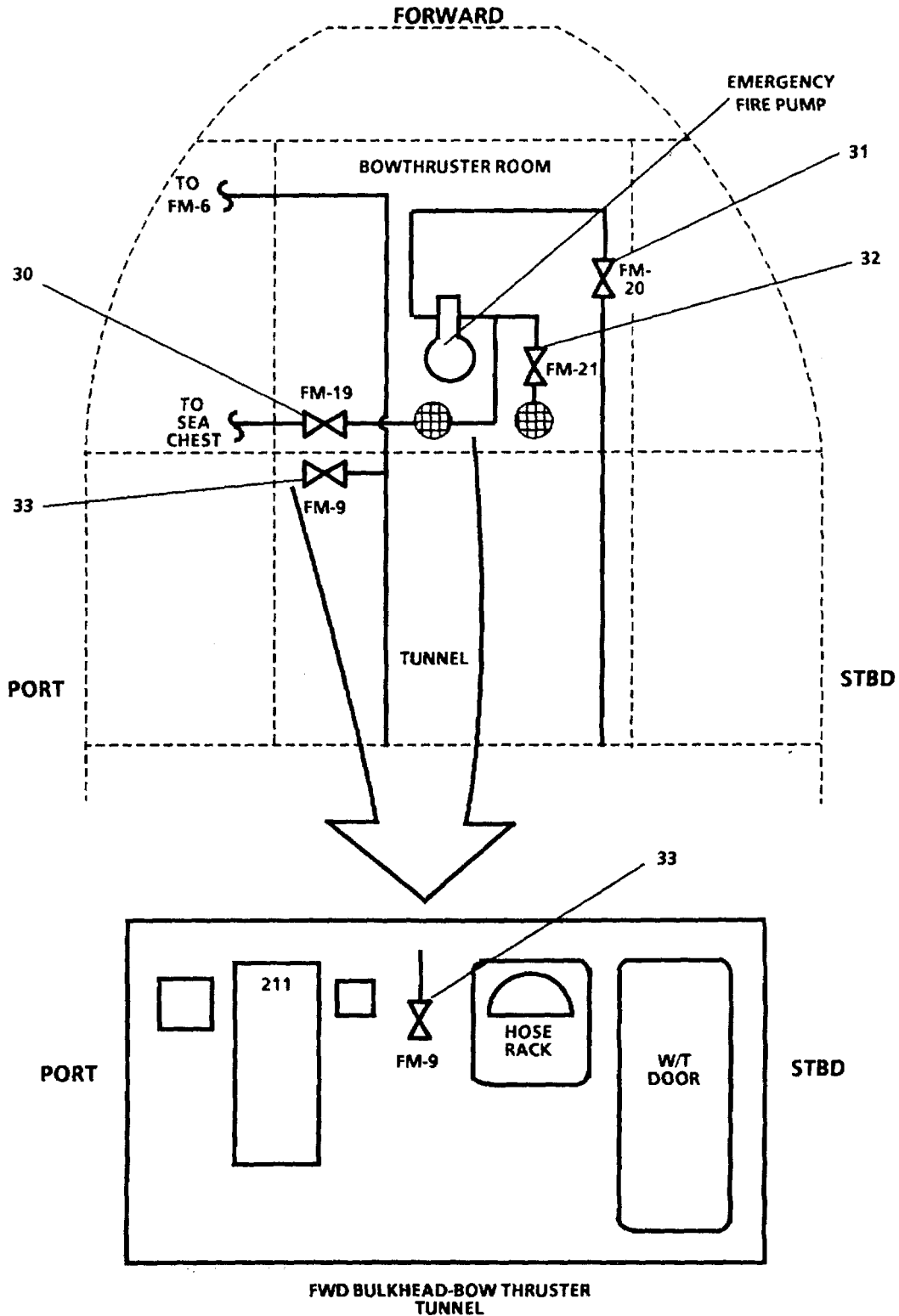

FIGURE 2-264. Fire Main and Foam Piping System (Sheet 6 of 12).

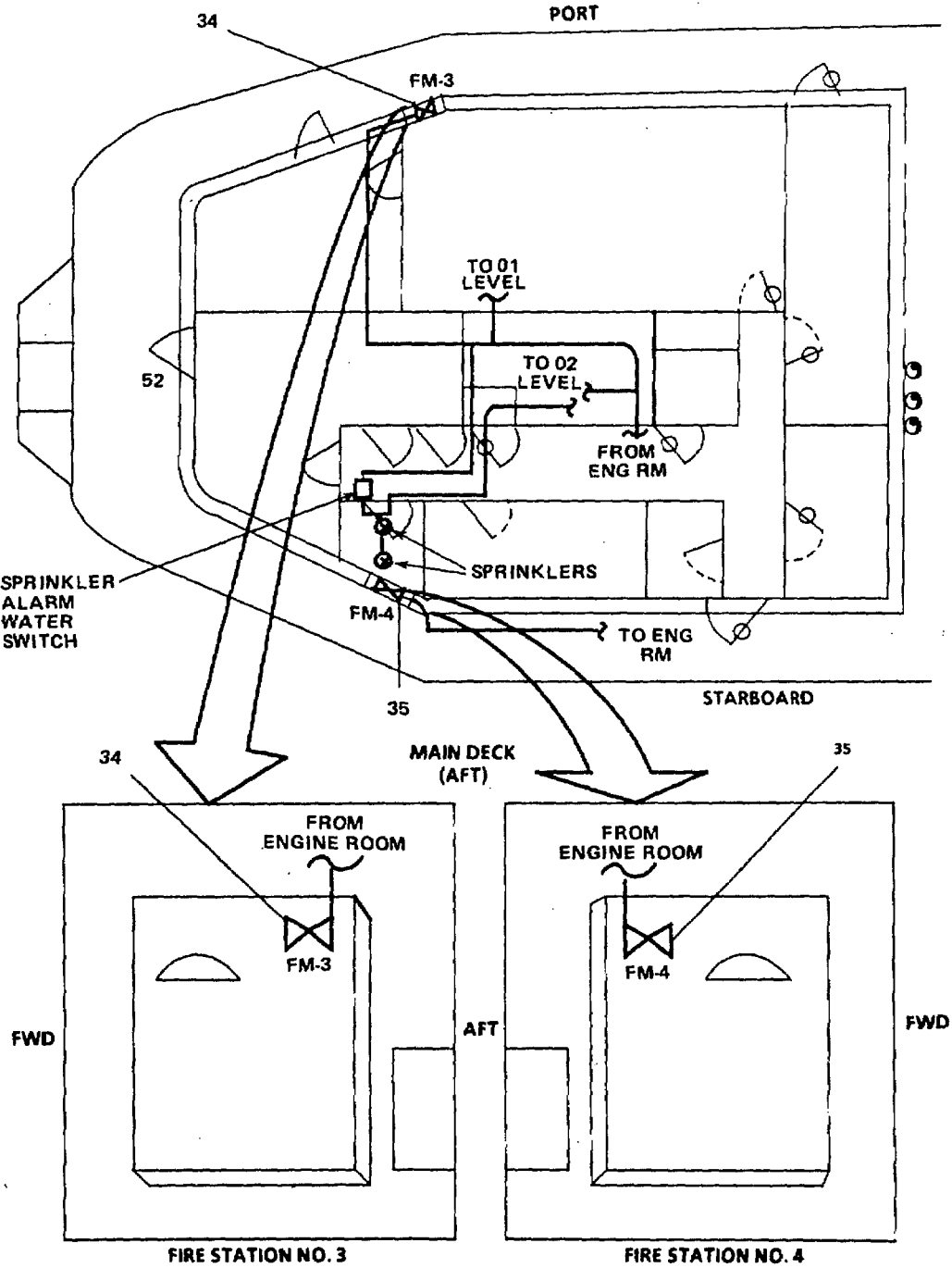

FIGURE 2-264. Fire Main and Foam Piping System (Sheet 7 of 12).

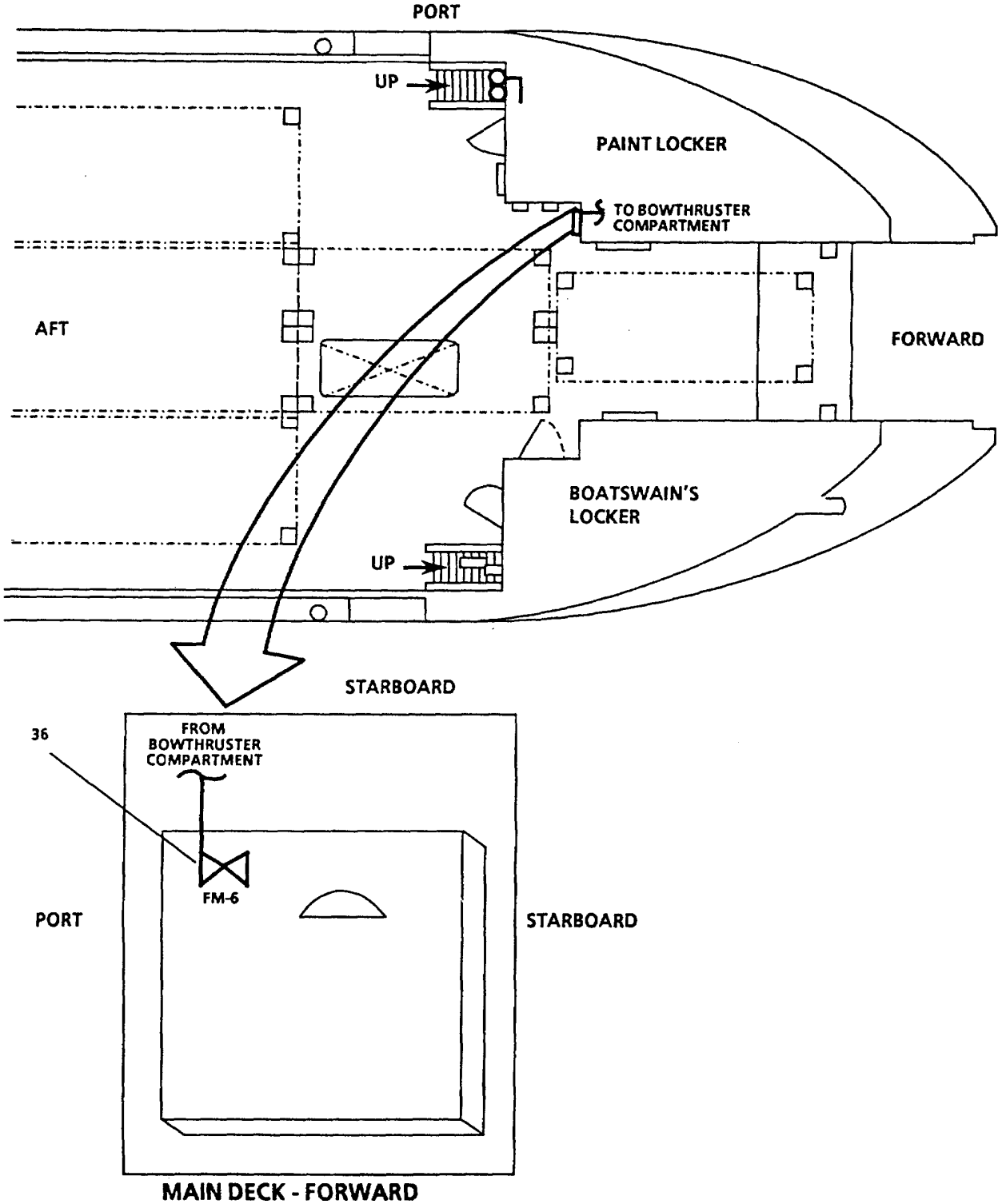

FIGURE 2-264. Fire Main and Foam Piping System (Sheet 8 of 12).

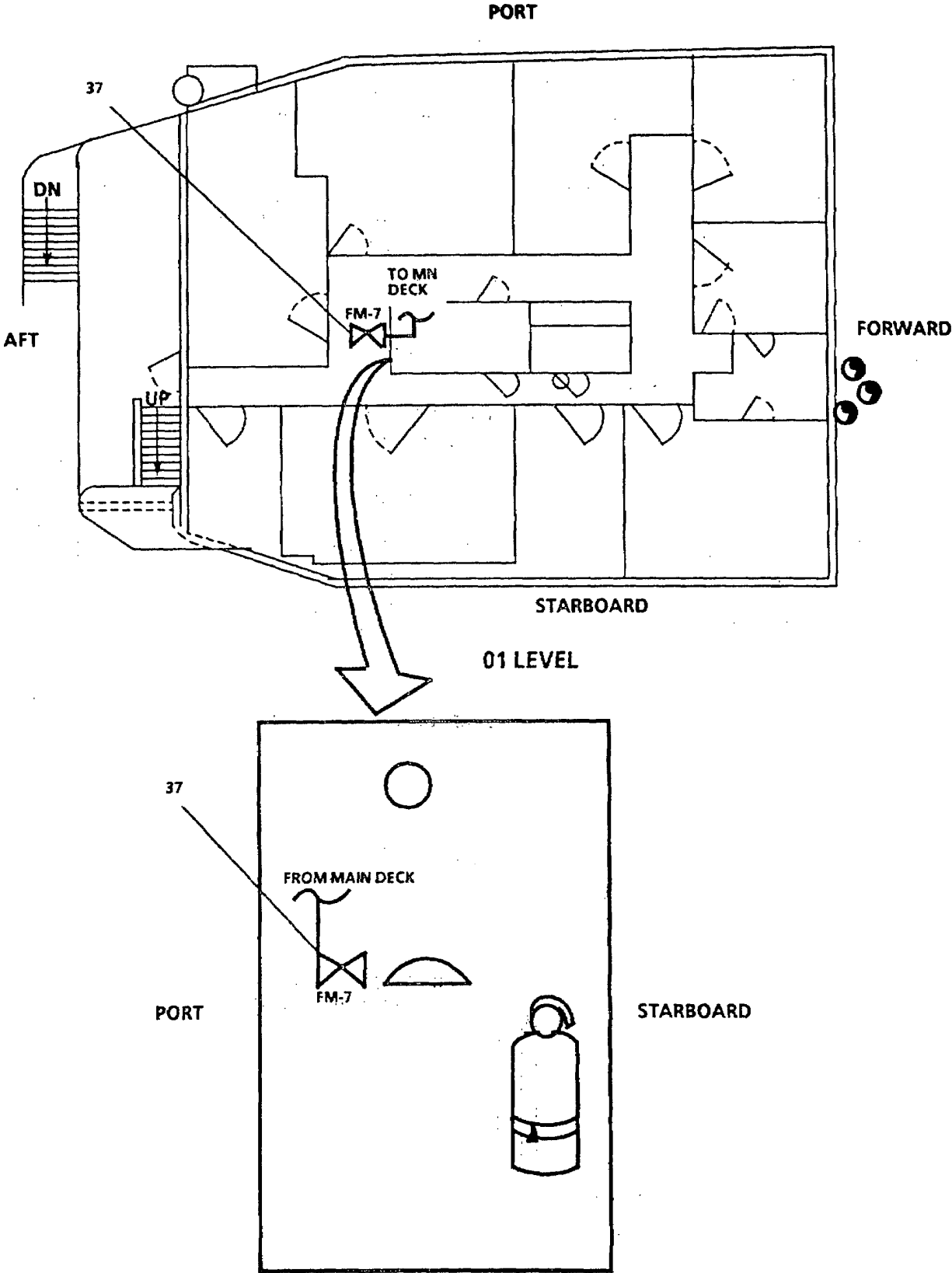

FIGURE 2-264. Fire Main and Foam Piping System (Sheet 9 of 12).

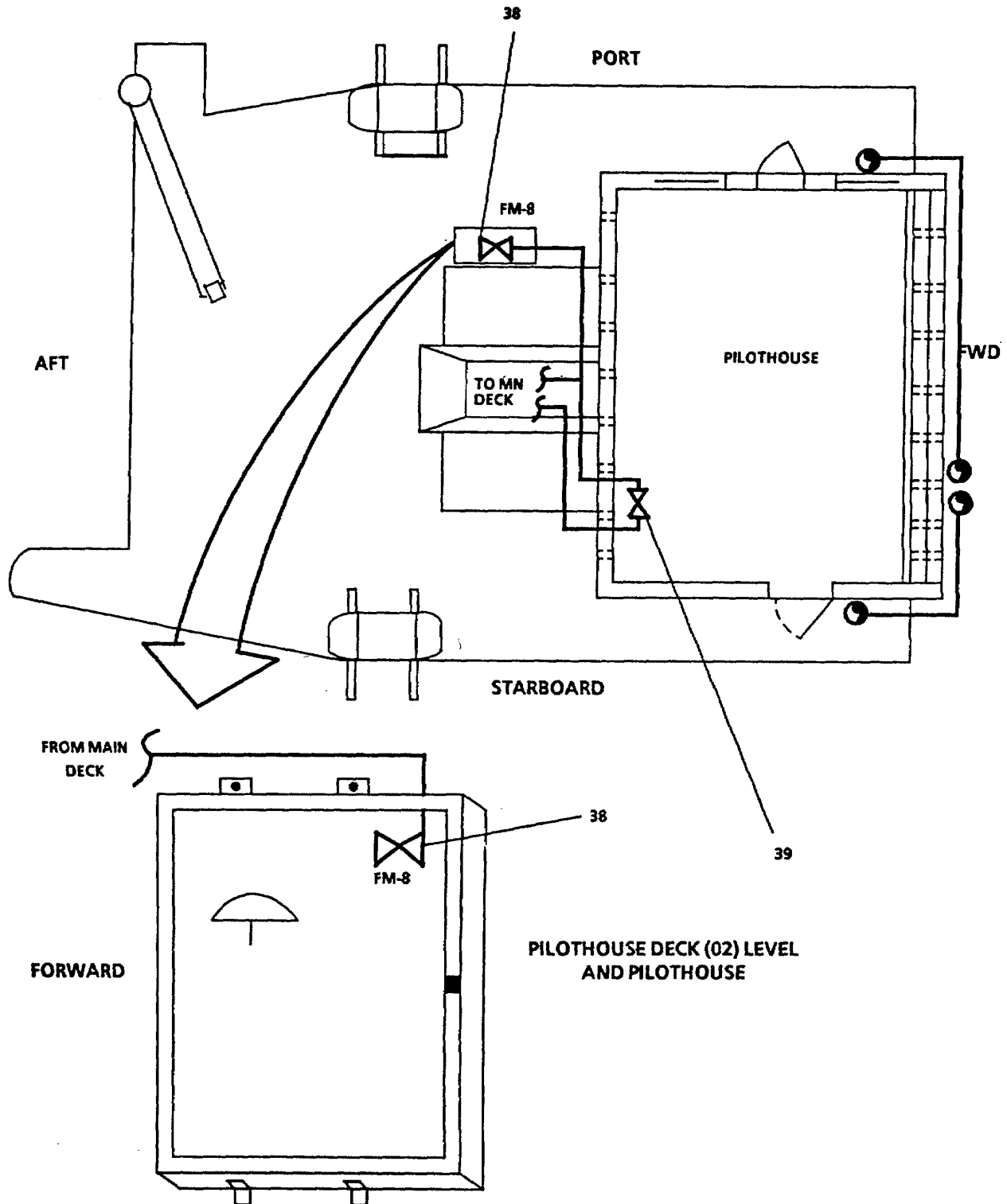

FIGURE 2-264. Fire Main and Foam Piping System (Sheet 10 of 12).

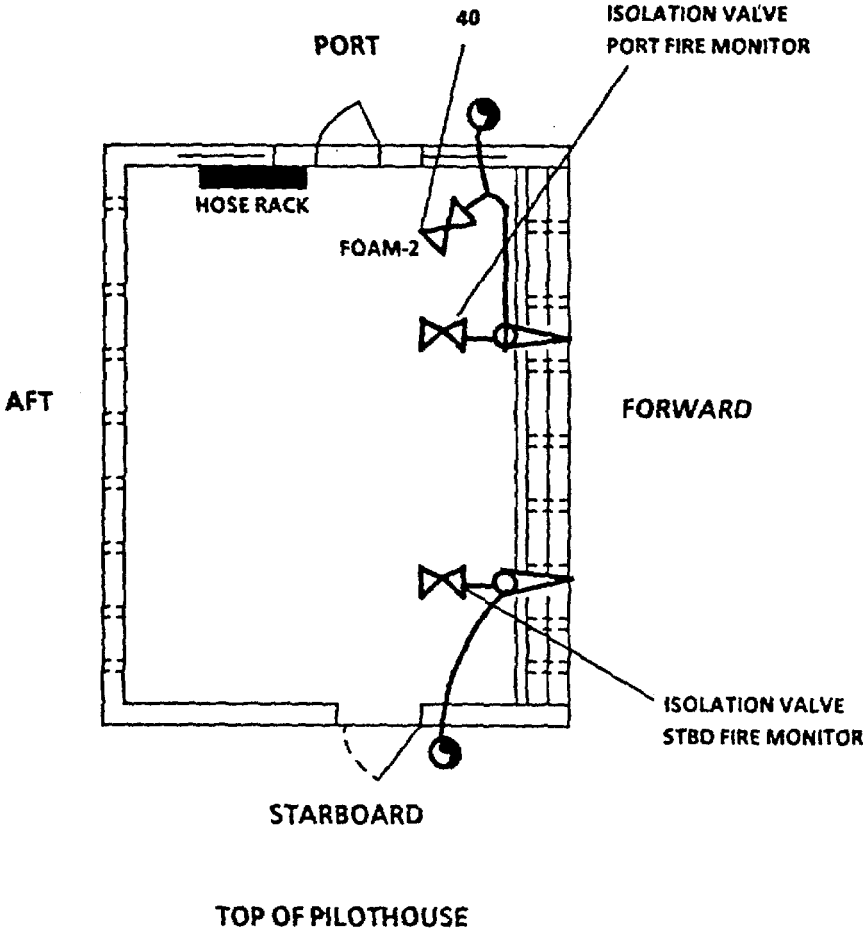

FIGURE 2-264. Fire Main and Foam Piping System (Sheet 11 of 12).

## LEGEND

- |  |   |
|--|---|
| 1. FM-2, FIRE STA 2 ISLN                         | 21. FM-18, FIRE PUMP NO. 1 SUCT                           |
| 2. FW-29, SEA CHEST HOT FW CONN                  | 22. FM-27, ENG RM EMERG BILGE SUCT                        |
| 3. BB-35, SEACHEST VENT ISOLATION                | 23. BB-25, ISLN-SEA CHEST                                 |
| 4. FM-1, FIRE STA 1 ISLN                         | 24. BB-24, SUCT-BILGE/BALLAST PUMP                        |
| 5. BB-36, SEACHEST VENT                          | 25. BB-22, ISLN - SEA CHEST                               |
| 6. FM-10, FIREMAIN ISLN                          | 26. BB-23 SEA CHEST SUCT                                  |
| 7. PRESSURE GAUGE ISOLATION                      | 27. BB-37, CROSS CONN TO BILGE MANIFOLD                   |
| 8. FM-22, CM WASHDOWN ISLN                       | 28. BB-38, CROSS CONN FIRE PUMP SUCT TO<br>BILGE MANIFOLD |
| 9. EDUCTOR                                       | 29. FM-13, FIREMAN & BALLAST CROSS CONN                   |
| 10. FOAM--1, FOAM STA 1 ISLN                     | 30. FM-19, EMERG FIRE PUMP                                |
| 11. FM-24, PORT FOAM MONITOR ISLN                | 31. FM-20, EMERG FIRE PUMP DISCH                          |
| 12. FM-23, STBD FOAM MONITOR ISLN                | 32. FM-21, EMERG BILGE SUCT                               |
| 13. FM-12 FOAM STA 1 & STBD MONITOR ISLN         | 33. FM-9, FIRE STA ISLN                                   |
| 14. FM-11, FOAM STA 2 & PORT MONITOR ISLN        | 34. FM-3, FIRE STA 3 ISLN                                 |
| 15. FM-15, NO. 2 FIRE PUMP DISCH                 | 35. FM-4 FIRE STA 4 ISLN                                  |
| 16. FM-154, NO. 1 FIRE PUMP DISCH                | 36. FM-6, FIRE STA 6 ISLN                                 |
| 17. FM-16, FIRE PUMP 1&2 SUCT CROSS CONN         | 35. FM-7, FIRE STA 7 ISLN                                 |
| 18. FM-17, FIRE PUMP NO. 2 SUCT                  | 38. FM-8, FIRE STA 8 ISLN                                 |
| 19. FM-26, NO. 2 FIRE PUMP STRAINER<br>ISOLATION | 39. ARMS ROOM SPRINKLER MANUAL<br>ACTIATION VALVE         |
| 20. FM-25, NO. 1 FIRE PUMP STRAINER<br>ISOLATION | 40. FOAM-2, FOAM STA 2 ISLN                               |

*FIGURE 2-264. Fire Main and Foam Piping System (Sheet 12 of 12).*



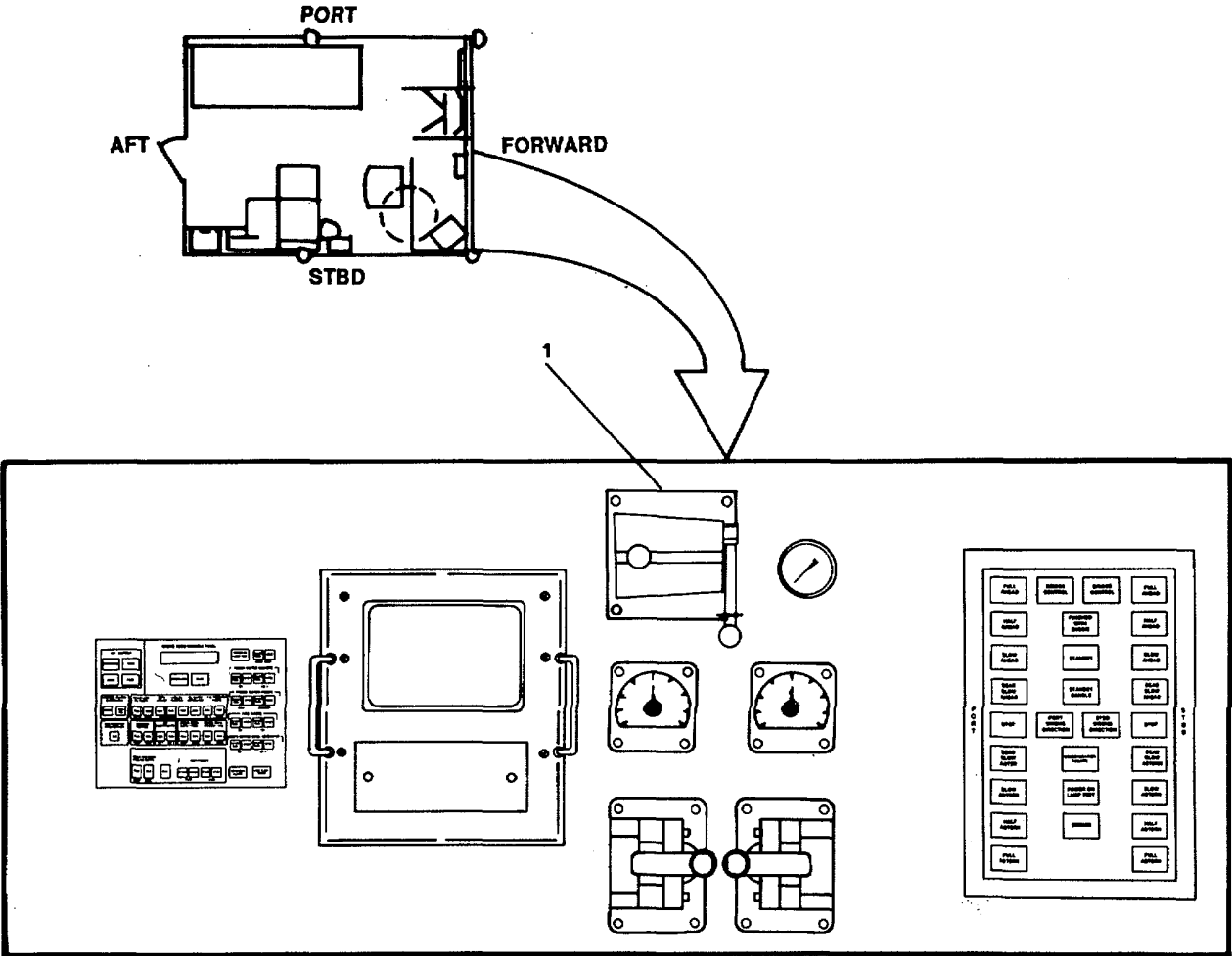

**LEGEND**  
1. CONTROL AIR SELECTOR

FIGURE 2-265. Engine Room Console.

- (11) Monitor pressure gauges mounted on aft bulkhead of bowthruster compartment. Pressure should be 105 PSI and maintained by engine speed.
- (12) If pump does not take a suction, bleed air from top of pump casing turning bleed valve 2 turns counterclockwise.

c. Operate fire monitors or foam station #1 and #2 without aqueous; film forming foam (AFFF).

- (1) Open FM-11, FOAM STA 2 AND PORT MONITOR ISLN (14, FIGURE 2-264).
- (2) Open FM-12, FOAM STA 1 AND STBD MONITOR ISLN (13).

d. Operate fire monitors, foam stations #1 and foam station #2 with AFFF.

- (1) Open FM-11, FOAM STA 2 AND PORT MONITOR ISLN (14, FIGURE 2-264).
- (2) Open FM-12, FOAM STA 1 AND STBD MONITOR ISLN (13).
- (3) Open FM-24, PORT FOAM MONITOR ISLN (11).
- (4) Open FM-23, STBD FOAM MONITOR ISLN (12).

e. Operate foam station 1 or foam station 2.

- (1) At foam station, remove hose and extend hose to its full length.
- (2) Open foam station's isolation valve.
- (3) Direct nozzle at fire and open nozzle's valve.

**CAUTION**

Hold nozzle in a firm grip. If not held firmly, the nozzle will thrash about and cause serious injury.

f. Operate countermeasure washdown

- (1) Ensure all weather deck hatches are secure.
- (2) Open FM-10, FIREMAIN ISLN (6).
- (3) Open FM-22, CM WASHDOWN ISLN (8).

g. Securing Emergency Fire Pump and Bowthruster from local operation.

- (1) Emergency Fire Pump. To secure the Emergency Fire Pump from local control perform the following:
  - (a) Reduce engine speed with throttle linkage to 650 rpm on RPM x 100 (1, FIGURE 2-243).
  - (b) Disengage power takeoff clutch by shifting clutch arm forward.
  - (c) Allow engine to idle for 3 minutes.

- (d) Place START switch (3) in DOWN position to stop engine.
- (e) Secure all valves after operation unless shifting control of operations to the bridge.

**2-56. Launch and Retrieve Workboat in Heavy Weather.**

**WARNING**

- Vessel needs to be steered so that port side is leeward before launching and retrieving rescue/workboat. Three crew members are required. To launch or retrieve rescue/workboat.
- All personnel working outdoors in heavy weather are required to wear life jackets.

a. Launch workboat (7. FIGURE 2-266).

- (1) Rotate CRANE (2), using CRANK HANDLE (3), until CRANE HOOK (1) is centered over WORKBOAT (7).
- (2) Connect LIFTING SLING (10) to four lifting rings of workboat.
- (3) Lower CRANE HOOK (1) by pressing DOWN button, located on CRANE WINCH CONTROL BOX (4).
- (4) Attach CENTER RING (g), of LIFTING SLING (10), to CRANE HOOK (1).
- (5) Attach BOW and STERN LINES (5 and 8) to each end of WORKBOAT (7) to manually guide workboat during launch.

**WARNING**

Do not attempt to lift or transport personnel with workboat crane. Serious injury or death could result.

- (6) Lift WORKBOAT (7, FIGURE 2-266) by pressing UP button, located on CRANE WINCH CONTROL BOX (4).
- (7) Have personnel man BOW and STERN LINES (5 and 8) to stabilize WORKBOAT (7) during launching operation.
- (8) Rotate CRANE (2), using CRANK HANDLE (3), until WORKBOAT (7) is suspended as far as possible over water.
- (9) Lower WORKBOAT (7) into water by pressing DOWN button, Located on CRANE WINCH CONTROL BOX (4).
- (10) Tie BOW and STERN LINES (5 and 8) to deck of LOU to keep WORKBOAT (7) from drifting.
- (11) Rig Jacob's ladder.

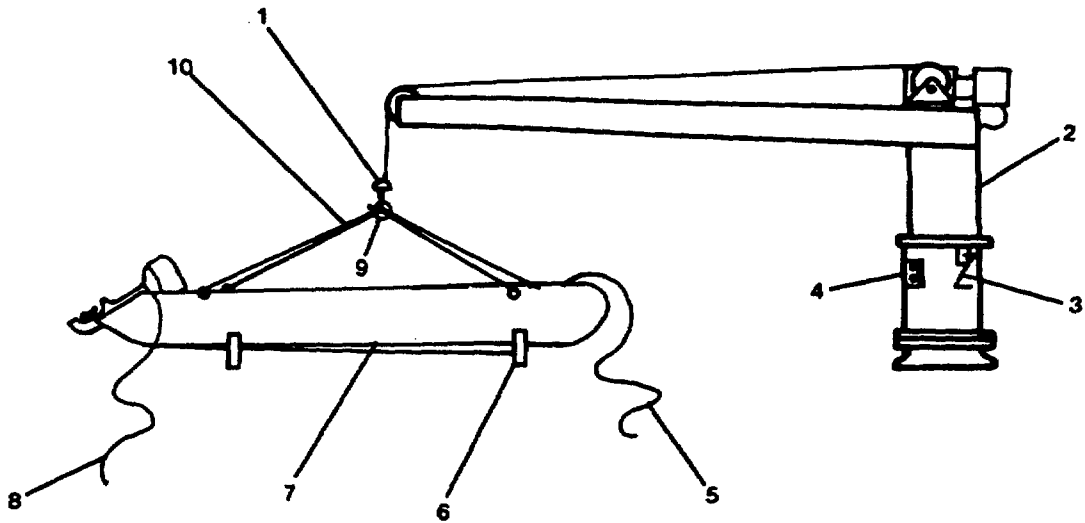

**LEGEND**

- |                            |                              |
|----------------------------|------------------------------|
| 1. DAVIT WINCH HOOK        | 6. CHOCK                     |
| 2. DAVIT                   | 7. WORKBOAT                  |
| 3. DAVIT CRANK HANDLE      | 8. STERN LINE                |
| 4. DAVIT WINCH CONTROL BOX | 9. LIFTING SLING CENTER RING |
| 5. BOW LINE                | 10. LIFTING SLING            |

8641

FIGURE 2-266. Workboat Launching and Retrieval.

**WARNING**

When boarding workboat in heavy weather, exercise extreme caution to avoid being thrown from Jacob's ladder or being struck by crane hook or lifting sling.

- (12) Board WORKBOAT (7) and disconnect LIFTING SLING (10) from WORKBOAT (7).
- (13) Raise CRANE WINCH HOOK (1) with LIFTING SLING (10) attached.
- (14) Disconnect BOW and STERN LINES (5) and (8).

b. Retrieve workboat (7. FIGURE 2-266).

- (1) Position WORKBOAT (7) alongside LCU, under WORKBOAT CRANE (2).
- (2) Throw BOW and STERN LINES (5 and 8) to personnel on deck of LCU.

**WARNING**

Exercise- extreme caution to avoid being struck by crane winch hook or lifting sling.

- (3) Lower CRANE HOOK (1), with LIFTING SLING (10) attached to crane at LIFTING SLING CENTER RING (9), by pressing DOWN button, located on CRANE WINCH CONTROL BOX (4).
- (4) Attach LIFTING SLING (10) to four lifting rings on WORKBOAT (7).

**WARNING**

Exercise extreme caution when climbing Jacob's ladder to avoid being thrown from ladder. Ascend ladder one person at a time.

- (5) Climb Jacob's ladder, one person at a time, to board LCU.
- (6) LIFT WORKBOAT (7) by pressing UP button, located on CRANE WINCH CONTROL BOX (4).
- (7) When WORKBOAT (7) is high enough to clear deck rail, rotate CRANE (2) by using CRANE HANDLE (3), until WORKBOAT (7) is over CHOCKS (6).
- (8) Lower WORKBOAT (7) onto CHOCKS (6) by pressing DOWN button, located on CRANE WINCH CONTROL BOX (4).
- (9) Disconnect LIFTING SLING (10) from WORKBOAT.

**2-57. Launch Liferafts.**

- a. Tie PAINTER LINE (8, FIGURE 2-267) secure to launching ramp.
- b. Launch liferaft as follows:

- (1) Open PELICAN HOOK (5) by prying LOCKING RING (4) up and over end of hook.
- (2) Release RETAINING STRAP (3).
- (3) TWO CREW MEMBERS TO LIFT liferaft (1) off CRADLE (7) and place on launch ramp, to release.
- (4) If liferaft does not inflate after hitting water, pull sharply on PAINTER LINE (8).

**NOTE**

- I Liferafts are equipped with HYDROSTATIC RELEASES (6) designed to release liferafts when submerged.
- I Three STRAPS (2 and 3) secured around liferaft container will release as liferaft inflates.

- (5) After boarding liferaft, cut PAINTER LINE (8).

**NOTE**

Midships liferaft is launched from either Port or Starboard Launching ramp following steps a and b above.

**2-58. Nuclear, Biological, and Chemical (NBC) Decontamination Procedures.**

**WARNING**

- I Interior is not a Positive Over Pressure System with doors and hatches closed. Stay in proper MOPP level.
- I Countermeasure washdown system only removes gross contamination, it does not completely decontaminate. Perform decontamination procedures in accordance with FM 3-5, NBC Decontamination.

a. Nuclear Fallout Decontamination.

- (1) Brush fallout from skin, clothing, and equipment with available brushes and rags. Wash skin and have radiation check made as soon as tactical situation permits.
- (2) To wash nuclear fallout from exterior of vessel, operate countermeasure washdown as follows:
  - (a) Ensure all hatches are secure.
  - (b) With fire main operational (Section III, paragraph 2-7), open FM-22, CM WASHDOWN ISLN (8, FIGURE 2-264).

b. Biological Decontamination.

The vessel crew has no method to detect or decontaminate biological agents. Remain masked and continue mission until told to unmask.

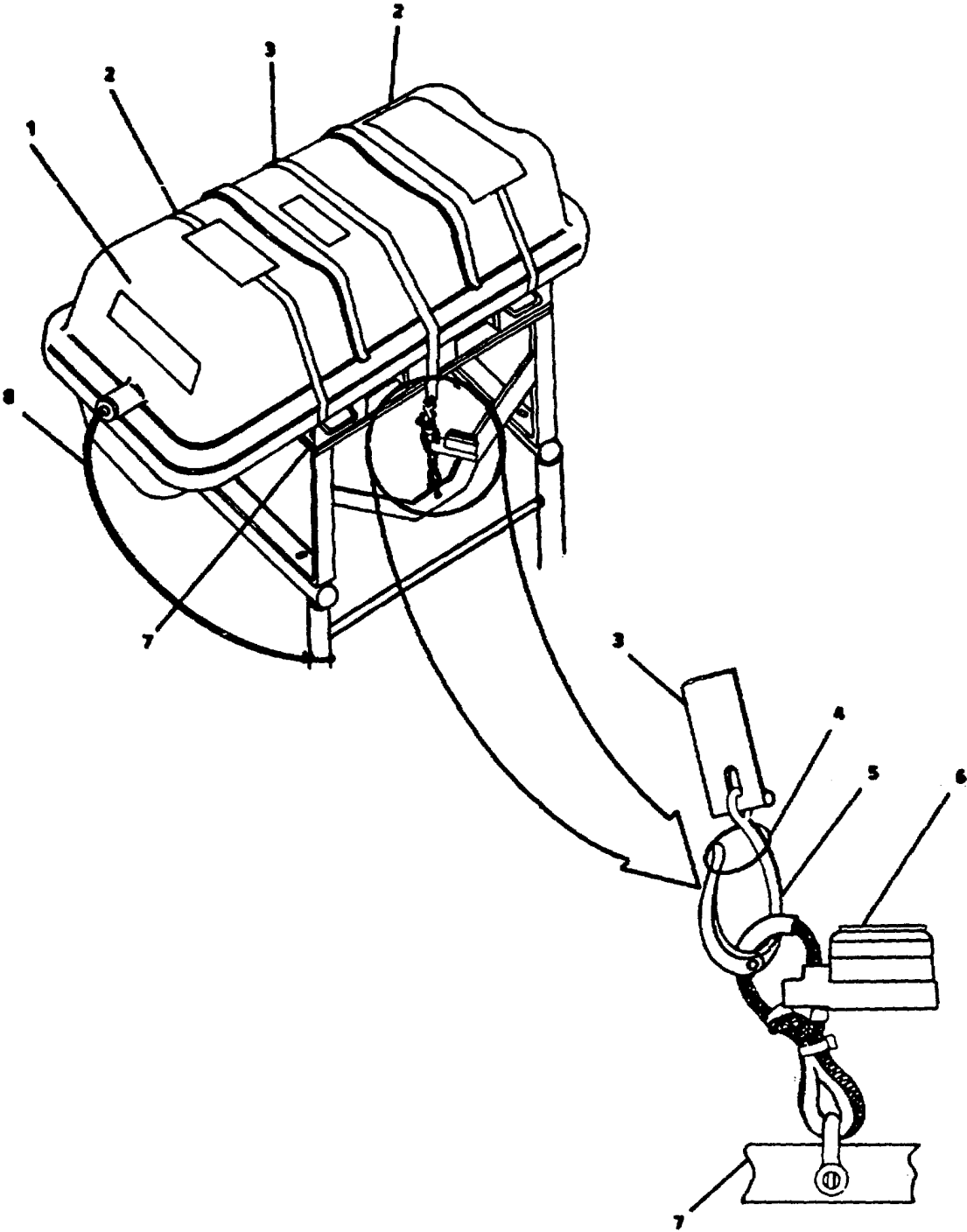

**LEGEND**

- 1. LIFERAFT CONTAINER
- 2. PRESSURE RELEASE STRAP
- 3. RETAINER STRAP
- 4. LOCKING RING
- 5. PELICAN HOOK
- 6. HYDROSTATIC RELEASE
- 7. CRADLE
- 8. PAINTER LINE

FIGURE 2-26. Liferaft Launching.

c. Chemical Detection and Decontamination.**WARNING**

Do not use decontamination spray on personnel. Injury could result.

- (1) Use M8 paper, from the chemical agent detection kit, or M9 paper to determine if liquid agent is present on vessel weather deck surfaces.
- (2) If exposure to liquid agent is known or suspected, clean exposed skin, clothing, and personal gear, in that order, using M258A1 kit. Use the buddy system. Wash exposed skin and thoroughly decontaminate as soon as tactical situation permits (see STP 21-1, Soldier's Manual of Common Tasks (Skill Level 1)).
- (3) If M8 or M9 paper indicates presence of liquid chemical agent on weather deck surfaces, use the countermeasures washdown system, as follows:
  - (a) Ensure all weather deck hatches are secure.
  - (b) With fire main operational (Section III, paragraph 2-7), open FM-22, CM WASHDOWN ISLN (8, FIGURE 2-264).

**2-59. Heavy Weather Preparations.****WARNING**

Unexpected roll or pitch of vessel can cause personnel to fall against live electrical circuits, rotating machinery or hot surfaces. Exercise extreme caution.

a. Secure weather decks.

- (1) Tie down workboat, crane and davits.
- (2) Stow all lines, hoses and loose equipment.
- (3) Secure and cover all hose and cable reels.
- (4) Secure and dog all hatches.
- (5) Rig storm lines if any work is to be performed on weather deck during heavy weather.

b. Secure pilothouse.

- (1) Secure all microphones or headsets in their holders.
- (2) Secure pencils, rulers, compasses, binoculars, and azimuth circle in chart table.
- (3) Secure coffee pot and tie down all chairs to desk or table legs.



c. Secure living spaces and mess deck.

- (1) Secure all pots, cups, dishes, and silverware in dining area.
- (2) Strap chairs to deck.
- (3) Secure loose personal gear in berthing spaces.

d. Secure galley.

- (1) Stop all food preparations that present a hazard, such as hot oil in fryer, steam, boiling water or hot liquids on stove. Secure power to all food preparation equipment. Do not turn off cold storage equipment.
- (2) Secure all pots, pans, cooking utensils, and coffee maker.
- (3) Secure any remaining loose items in galley.

e. Secure engine and machinery spaces

- (1) Secure all loose items, equipment, and tools.
- (2) Stop all non-essential maintenance. If maintenance work is absolutely essential, work in pairs.

**2-60. Transfer of Fuel Using Hand Pump.****CAUTION**

This procedure assumes that none of the main engines or diesel generators are operating. If any engines are operating, consult chief engineer before proceeding.

- a. Close all valves in fuel oil transfer piping system (FIGURE 2-268).
- b. Open FO-46, HAND PUMP SUCT (33) and FO-45, HAND PUMP DISCH (32).
- c. Open FO-48, BYPASS FILTER, SEPARATOR (34).
- d. Open FO-4, DISCHARGE VALVE (2) to supply manifold.
- e. Determine which tanks are to receive fuel and align, as follows:
  - (1) If F-3P is to receive fuel, open FO-6, SUPPLY TO TK F-3P (58).
  - (2) If F-3S is to receive fuel, open FO-8, SUPPLY TO TK F-3S (57).
  - (3) If F-4P is to receive fuel, open FO-5, SUPPLY TO TK F-4P (59).
  - (4) If F-4S is to receive fuel, open FO-9, SUPPLY TO TK F-4S (61).
  - (5) If F-12P is to receive fuel; open FO-10, SUPPLY TO DAY TK F-12P (56).
  - (6) If F-12S is to receive fuel, open FO-14, SUPPLY TO DAY TK F-12S (64).

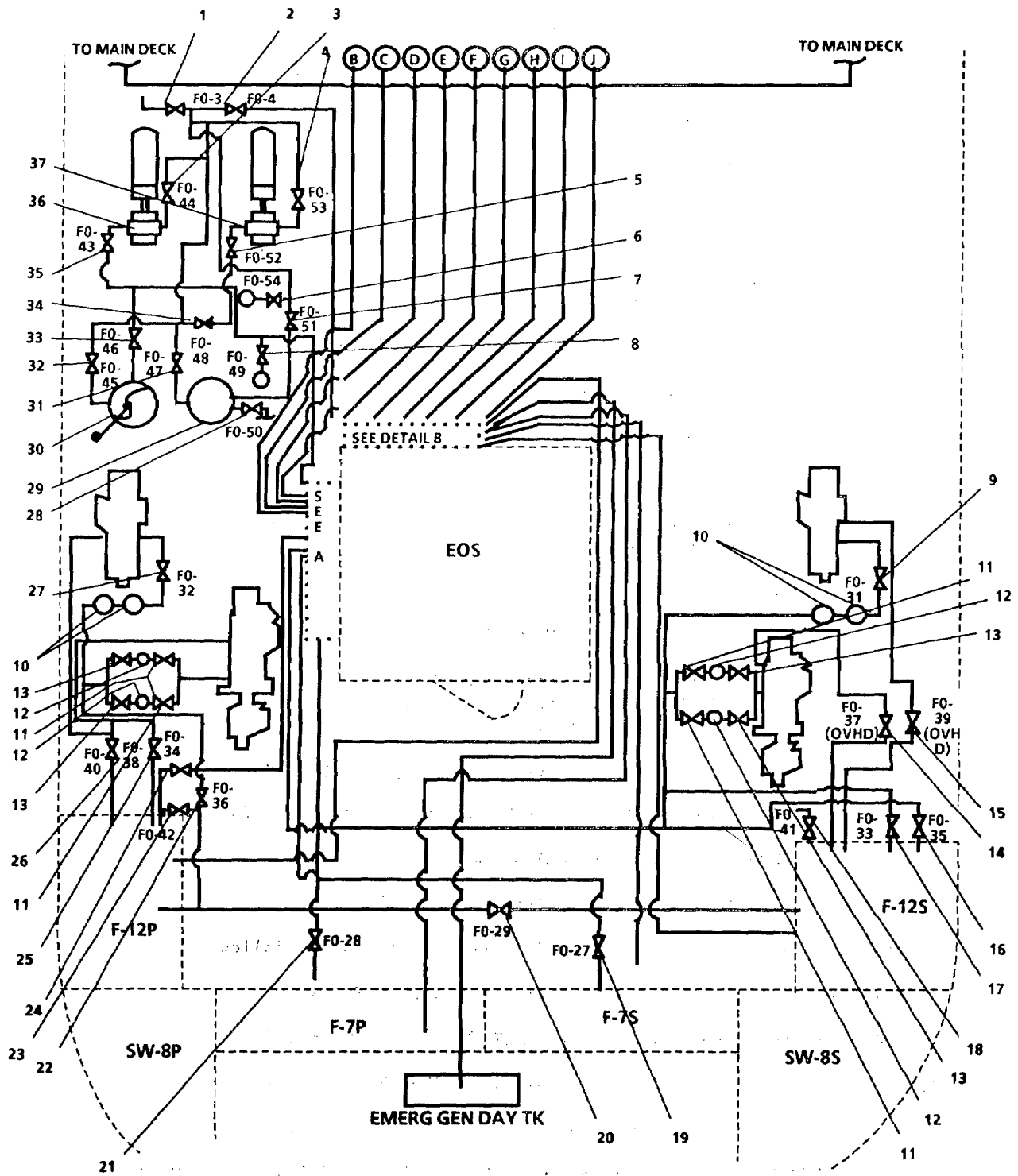

FIGURE 2-268. Fuel Oil Filter, Transfer and Supply Piping System (Sheet 1 of 6)

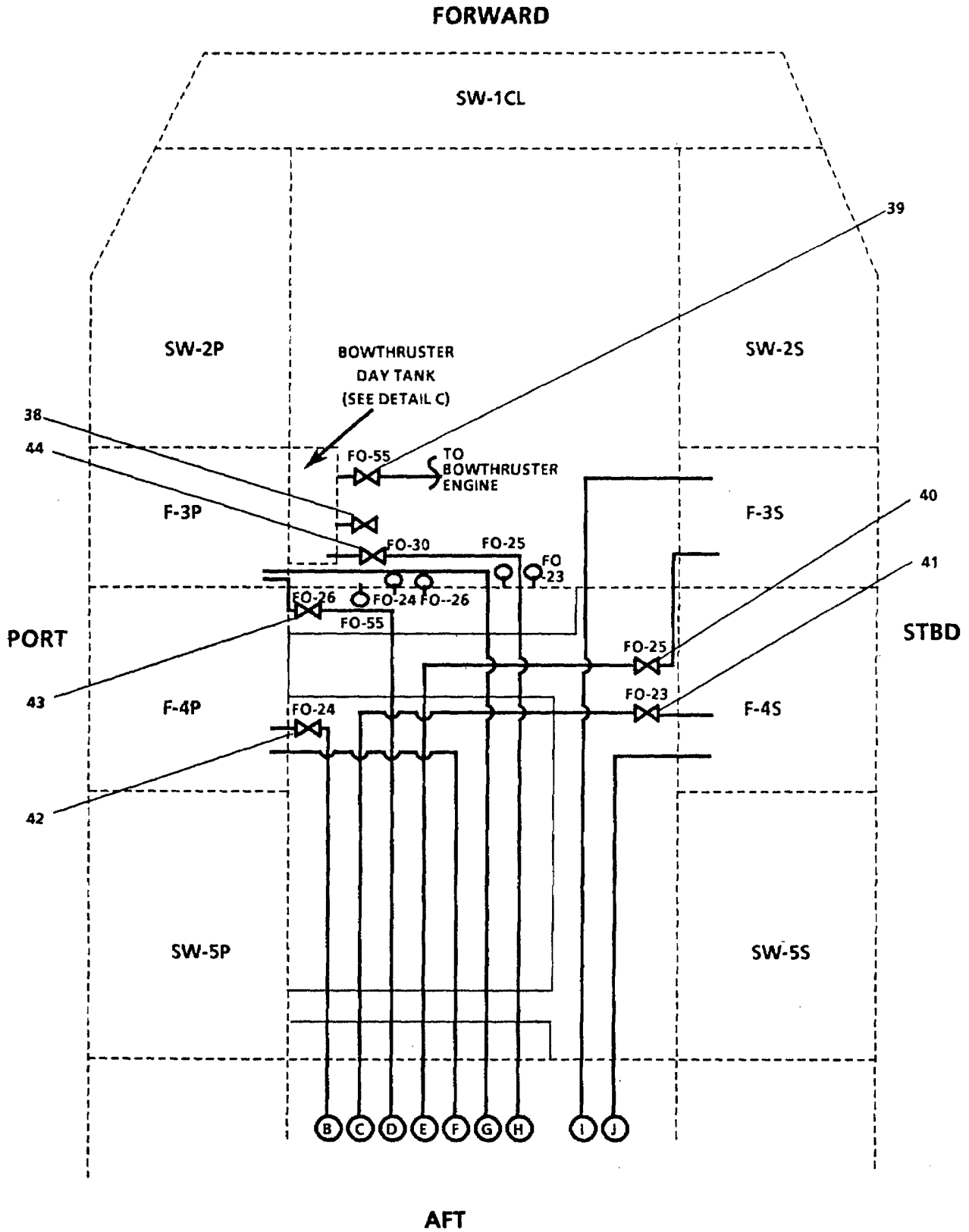

FIGURE 2-268. Fuel Oil Filter, Transfer and Supply Piping System (Sheet 2 of 6)

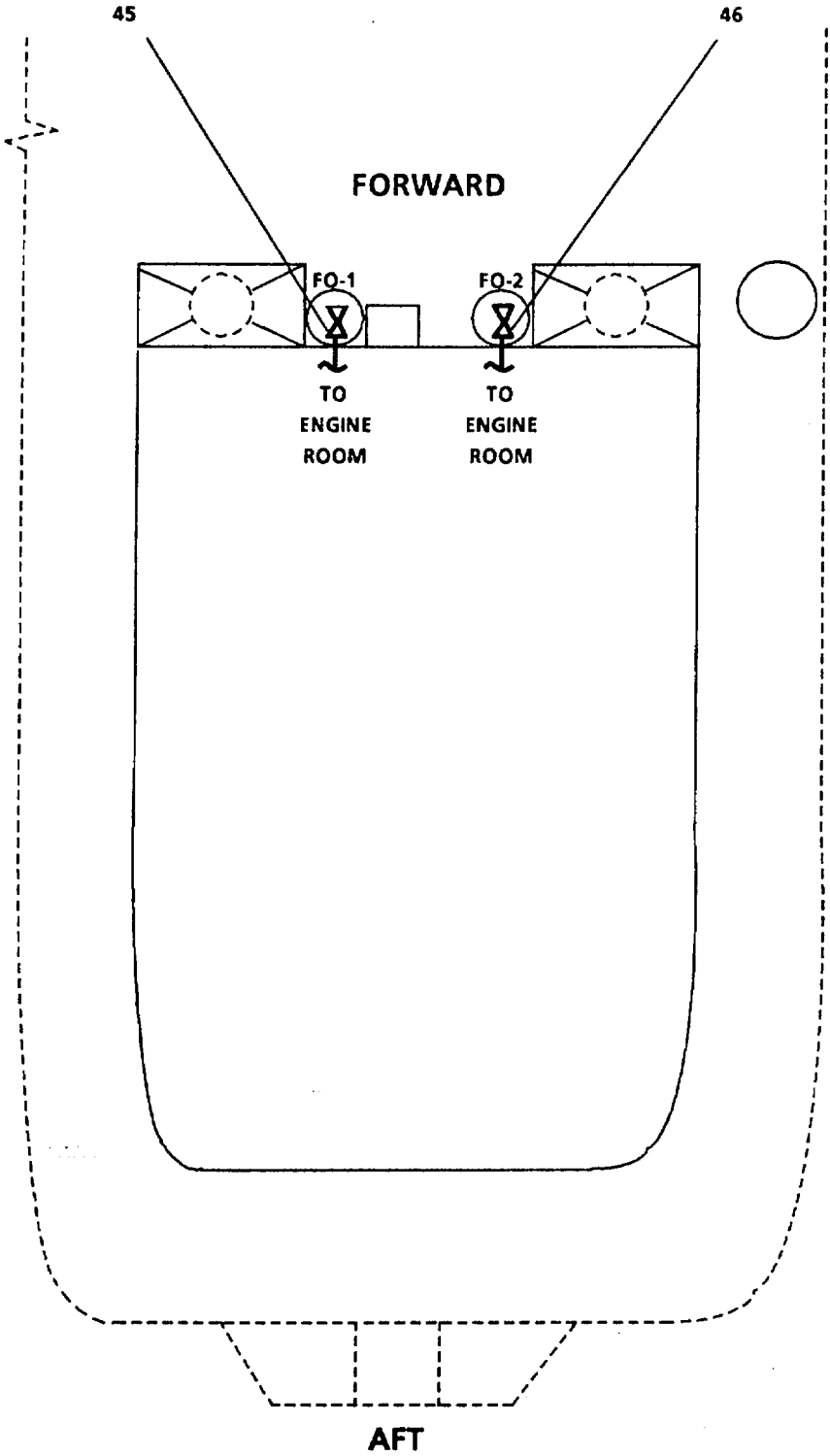
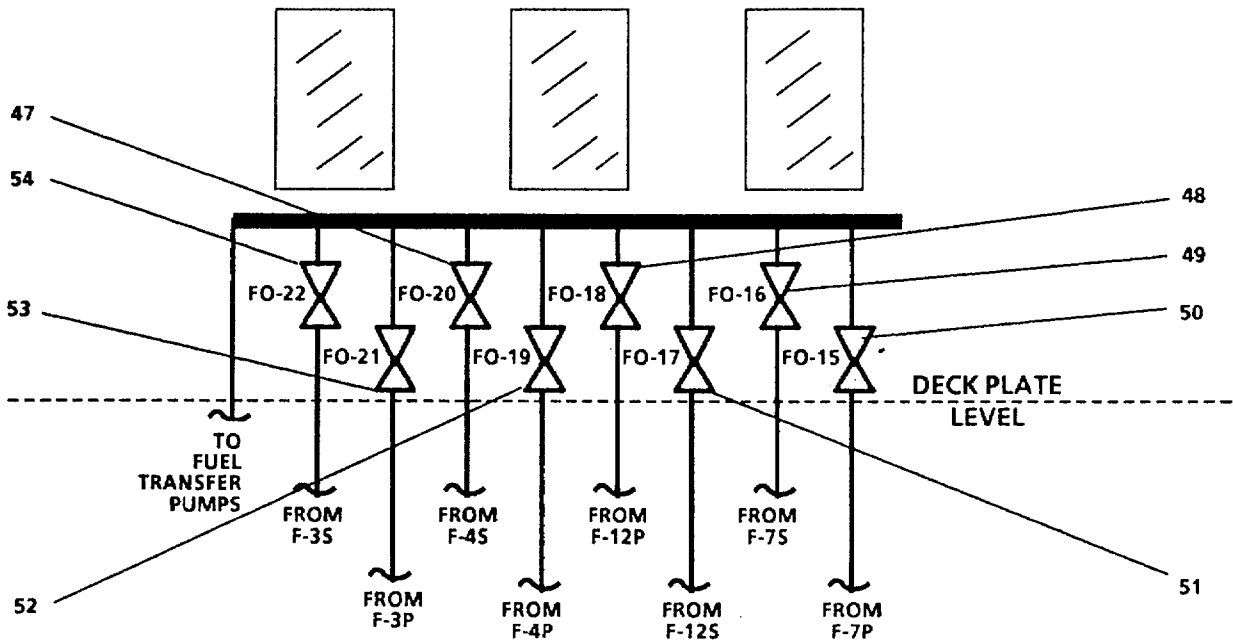

FIGURE 2-268. Fuel Oil Filter, Transfer and Supply Piping System (Sheet 3 of 6)

**DETAIL A  
PORT EXTERIOR BULKHEAD  
OF EOS (FORWARD)**



**DETAIL B  
FORWARD EXTERIOR BULKHEAD  
OF EOS (PORT)**

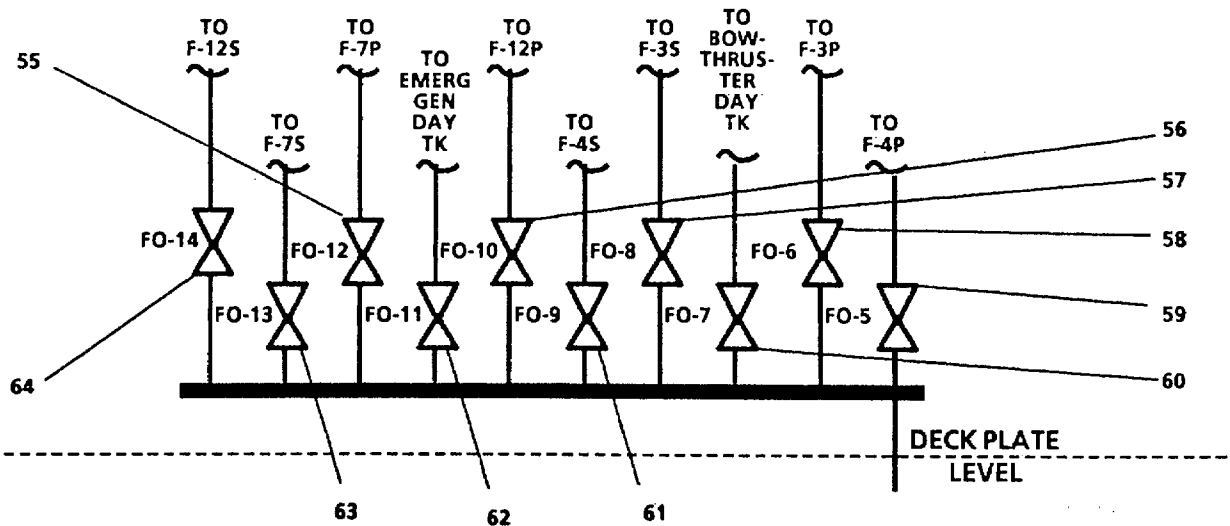

FIGURE 2-268. Fuel Oil Filter, Transfer and Supply Piping System (Sheet 4 of 6)

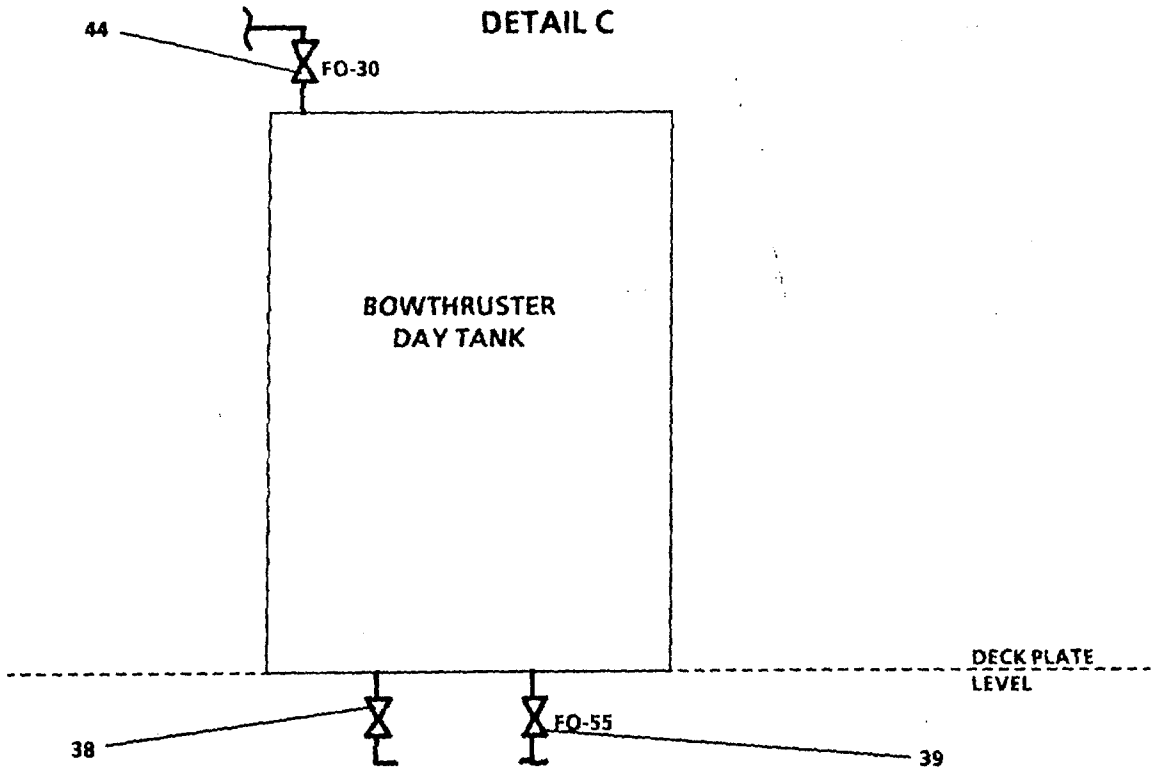

FIGURE 2-268. Fuel Oil Filter, Transfer and Supply Piping System (Sheet 5 of 6)

## LEGEND

- |  |  |
|--|--|
| 1. FO-3, 1SLN-FILL/DISCH STATIONS                    | 33. FO-46, HAND PUMP SUCT                |
| 2. FO-4, SUPPY TO FO SUPPLY MANF                     | 34. FO-48, BY-PASS FILTER/SEPARATOR      |
| 3. FO-44, DISCH -NO. 2 XFR PUMP                      | 35. FO-43, SUCT-NO. 2 XFR PUMP           |
| 4. FO-53, DISCH- NO.1 XFR PUMP                       | 36. NO. 2 XFR PUMP                       |
| 5. FO-52, SUCT-NO. 1 XFR PUMP                        | 37. NO. 1 XFR PUMP                       |
| 6. FO-54, PUMP DISCH PRESS GAGE                      | 38. BOW THRUSTER DAY TK DRAIN            |
| 7. FO-51, FILTER/SEPARATOR OUTLET                    | 39. FO-55, SUPPLY TO BOW THRUSTER ENGINE |
| 8. FO-49, PUMP SUCT PRESS GAGE                       | 40. FO-25, SUCT FR TK F-3S               |
| 9. FO-31, SUPPLY TO STBD SSDG                        | 41. FO-23, SUCT FR TK F-4S               |
| 10. SSDG FUEL FILTERS                                | 42. FO-24, SUCT FR TK F-4P               |
| 11. MN ENG FILTER DISCH VALVE                        | 43. FO-26, SUCT FR TK F-3P               |
| 12. MN ENG FILTER                                    | 44. FO-30, SUPPLY TO BOW THRUSTER DAY TK |
| 13. MN ENG FILTER INLET VALVE                        | 45. FO-1, FUEL OIL FILL/DISCH            |
| 14. FO-37, RETURN FR STBD MN ENG TO DAY TK F-12S     | 46. FO-2, FUEL OIL FILL/DISCH            |
| 15. FO-39, RETURN FR STBD SSDG TO DAY TK F-12S       | 47. FO-20, SUCT FR TK F-4S               |
| 16. FO-35, SUCT FR DAY TK F-125                      | 48. FO-18, SUCT FR TK F-12P              |
| 17. FO-33, DAY TK F-12S SUPPLY TO STBD MN ENG & SSDG | 49. FO-16, SUCT FR TK F-7S               |
| 18. FO-41, DRAIN FR DAY TK F-125                     | 50. FO-15, SUCT FR TK F-7P               |
| 19. FO-27, SUCT FR TK F-7S                           | 51. FO-17, SUCT FR TK F-125              |
| 20. FO-29, CROSS CONN - DAY TKS                      | 52. FO-19, SUCT FR TK F4P                |
| 21. FO-28, SUCT FR TK F-7P                           | 53. FO-21, SUCT FR TK F-3P               |
| 22. FO-36, DAY TK F-12P SUPPLY TO PORT MN ENG & SSDG | 54. FO-22, SUCT FR TK F-3S               |
| 23. FO-42, DRAIN FR DAY TK F-12P                     | 55. FO-12, SUPPLY TO TK F-7P             |
| 24. FO-34, SUCT FR DAY TK F-12P                      | 56. FO-10, SUPPLY TO DAY TK F-12P        |
| 25. FO-38, RETURN FR PORT MN ENG TO DAY TK F-12P     | 57. FO-8, SUPPLY TO TK F-3S              |
| 26. FO-40, RETURN FR PORT SSDG TO DAY TK F-12P       | 58. FO-6, SUPPLY TO TK F-3P              |
| 27. FO-32, SUPPLY TO PORT SSDG                       | 59. FO-5, SUPPLY TO TK F4P               |
| 28. FO-50, DRAIN TO SLUDGE TK                        | 60. FO-7, SUPPLY TO TO BOW THRUSTER DAY  |
| TK   |  |
| 29. FUEL FILTER/COALESCER                            | 61. FO-9, SUPPLY TO TK F-4S              |
| 30. FUEL TRANSFER HAND PUMP                          | 62. FO-11, SUPPY TO EMER GEN DAY TK      |
| 31. FO-47, FILTER/SEPARATOR INLET                    | 63. FO-13, SUPPY TO TK F-7S              |
| 32. FO-45, HAND PUMP DISCH                           | 64. FO-14, SUPPY TO TK F-12S             |

FIGURE 2-268. Fuel Oil Filter, Transfer and Supply Piping System (Sheet 6 of 6).

- (7) If F-7P is to receive fuel, open FO-12, SUPPLY TO TK F-7P (55).
- (8) If F-7S is to receive fuel, open FO-13, SUPPLY TO TK F-7S (63).
- (9) If the EMERG GEN DAY TK is to receive fuel, open FO-11, SUPPLY TO EMERG GEN DAY TK (62).
- (10) If the BOWTHRUSTER DAY TK is to receive fuel, open FO-7, SUPPLY TO BOW THRUSTER DAY TK (60).

f. Align tanks that fuel is to be pumped from as follows:

- (1) If fuel is to be pumped from F-3P, open FO-26, SUCT FR TK F-3P (43) and FO-21, SUCT FR TK F-3P (53).
- (2) If fuel is to be pumped from F-3S, open FO-25, SUCT FR TK F-3S (40) and FO-22, SUCT FR TK F-3S (54).
- (3) If fuel is to be pumped from F-4P, open FO-24, SUCT FR TK F-4P (42) and FO-19, SUCT FR TK F-4P (52).
- (4) If fuel is to be pumped from F-4S, open FO-23, SUCT FR TK F-4S (41) and FO-20, SUCT FR TK F-4S (47).
- (5) If fuel is to be pumped from F-12P, open FO-34, SUCT FR DAY F-12P (24) and FO-18, SUCT FR DAY TK F-12P (48).
- (6) If fuel is to be pumped from F-12S, open FO-35, SUCT FR DAY TK F-12S (16) and FO-17, SUCT FR DAY TK F-12S (51).
- (7) If fuel is to be pumped from F-7P, open FO-28, SUCT FR TK F-7P (21) and FO-15, SUCT FR TK F-7P (50).
- (8) If fuel is to be pumped from F-7S, open FO-27, SUCT FR TK F-7S (19) and FO-16, SUCT FR TK F-7S (49).

**NOTE**

Before operating handpump turn on tank level indicators.

g. Operate FUEL TRANSFER HAND PUMP (30), by turning handle in a clockwise direction, to transfer fuel.

h. After fuel has been transferred, close all valves in fuel oil transfer piping system.

**2-61. Shore Power Connections.**

**WARNING**

Ensure that power cable does not enter water. Electrocution, serious injury, or equipment damage can occur during connection if cable connector gets wet.



- a. Pay out power cable from overhead rack up ladder to the 02 stern deck.
- b. Position cable end through bottom section of hand rail.
- c. Tie one end of heaving line to cable end.
- d. Throw heaving line to dockside facilities.

**NOTE**

There are 75 feet of cable; direct attention to the amount of cable remaining on the deck. There should be a sufficient amount of cable on the deck to prevent it from paying out completely. Attach a preventer line to prevent complete cable runoff.

- e. Coordinate cable payout between onboard and dockside crew.
- f. Connecting cables (FIGURE 2-269).

**WARNING**

- Ensure that no electrical power is applied to dock connections prior to connecting shore power cables.
- Ensure shore ends of cable are connected to the proper phased connection. Shore power facilities may vary in arrangement and method of hook-up.

- (1) Loosen two TERMINAL COVER bolts (4) holding TERMINAL COVER (1).
- (2) Open TERMINAL COVER (1).
- (3) Remove PIPE PLUG (11).
- (4) Install cable (12) into terminal box.

**NOTE**

Consult phase tags to ensure proper wire to terminal connection.

- (5) Connect wire (3) to top "Ground" TERMINAL (2).
- (6) Connect wire (5) to top "A" PHASE TERMINAL (6).
- (7) Connect wire (9) to middle "B" PHASE TERMINAL (10).
- (8) Connect wire (7) to bottom "C" PHASE TERMINAL (8).

**NOTE**

After installing cables into shore power terminal box follow shifting to shore power procedures in paragraph 2-34b.

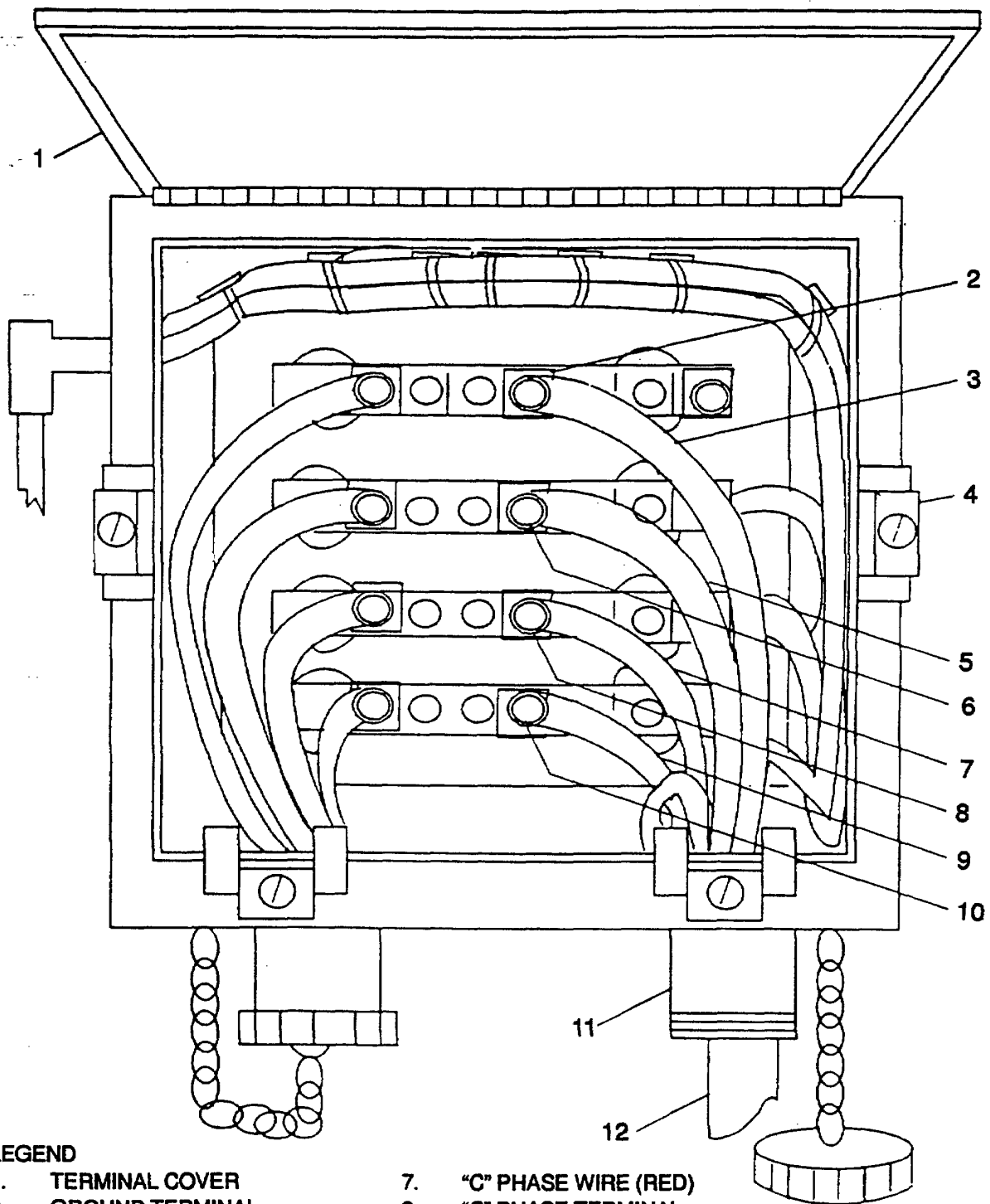

**LEGEND**

- |                           |                           |
|---------------------------|---------------------------|
| 1. TERMINAL COVER         | 7. "C" PHASE WIRE (RED)   |
| 2. GROUND TERMINAL        | 8. "C" PHASE TERMINAL     |
| 3. GROUND WIRE (BLACK)    | 9. "B" PHASE WIRE (WHITE) |
| 4. TERMINAL COVER BOLTS   | 10. "B" PHASE TERMINAL    |
| 5. "A" PHASE WIRE (BLACK) | 11. PIPE PLUG             |
| 6. "A" PHASE TERMINAL     | 12. CABLE                 |

FIGURE 2-269. Onboard Shore Power Terminal Box.

**2-62. Emergency Control for AHEAD Only.**

- a. If the pressure oil supply fails, emergency control is possible with the aid of hexagon screw K 8.
- b. For this purpose, the engine must be shut down. Upon removal of the locking wire, the hexagon nuts K 9, hexagon screws K 8 are to be tightened while the clutch is being rotated evenly. This results in the disc packet being pressed together and the disc clutch becoming force-locked.
- c. It is necessary to ensure that, during emergency control, only the AHEAD clutch is blocked. In the case of gearboxes with AHEAD output direction of rotation against the input (engine) direction of rotation, this is the clutch on the input shaft W 1. If input and AHEAD output directions of rotation are identical, the clutch fitted to the intermediate shaft W 20, arranged on the side, must be locked.
- d. Before re-starting the engine, the gearbox control lever must be shifted to STOP. It must not be shifted to ASTERN, as this would block the gearbox.
- e. Location of K 8, K 9, W 1, and W 20 may be found in TM 55-1905-223-24P-1: Page 43-2 for items 48, 49, and 79; Page 44-1 for items 17 and 18; and page 44-2 for item 48.

**Change 7 2-720**

**2-63. FM-200 Fire Suppressant System.**

- a. Authority To Actuate FM-200 Systems. The authority to actuate the FM-200 fixed fire extinguishing system protecting engine room, tunnel, bow thruster room, paint locker and air conditioner and emergency generator room will be issued by the person in charge at the scene.
- b. Actuation Procedures, Engine Room FM-200 System. All fire scenarios and situations leading to the decision when to actuate the FM-200 total flooding fire extinguishing system are not intended to be discussed here. Refer to the US Army Fire Fighting Doctrine for guidance. However, the following steps must be completed to effectively deploy the FM-200 as designed.

In the event the FM-200 Fixed Fire Fighting System is to be actuated, the following steps must be accomplished prior to activation of the system.

- (1) Evacuate All Personnel From Space.

**WARNING**

**In the event the FM-200 System electric horn/strobe or warning lights (amber strobe) are activated, leave the protected space immediately.**

**FM-200 is being released within 60 seconds, death or serious injury could occur.**

The Watch Officer or on-scene commander must ensure all personnel have evacuated the space and are all accounted for.

- (2) Activate The Water Washdown System (WWS). In order to operate the WWS, the fire main system must be charged. Ensure that the Bow Thruster Emergency Fire Pump is placed on line to the maximum operating pressure.

**WARNING**

**The Water Washdown System (WWS), installed to augment the the engine room FM-200 System, shall be activated prior to actuation of the FM-200 Fixed Fire Extinguishing System.**

**To provide adequate flow of seawater to the engine room WWS, the bow thruster emergency fire pump must be operated at a minimum pressure of 121 psi.**

**During operation of the WWS, sufficient fire main capacity exists for four (4) 1 ½" fire hoses at full stream or nine (9) 1 ½" hoses at spray.**

**Failure to operate bow thruster emergency pump at 121 psi could result in equipment damage or serious injury to personnel.**

**CAUTION**

**The WWS should always be ready to immediately deploy by disengaging the locking mechanism on the ball valve handle. pad locking of this handle should only occur during system maintenance or equipment damage, death or serious injury could occur.**

**NOTE**

**Actual location may vary slightly between vessels.**

Activate the WWS by unlocking and opening valve WWS-1, Engine Room WWS Control Valve, located in the Starboard Passage (1-33-0-L), Main Deck Level, Frame 41, Engine Room WWS Control Station. Refer to paragraph 2-64 for operation of the Water Washdown System (WWS).

- (3) Secure Ventilation. Secure powered ventilation systems to the protected space. This can be accomplished from the Engineer's Operating System (EOS), Motor Control Center (MCC) and locally at the equipment if the situation allows during the evacuation process, at the FM-200 Storage Cylinders located in the Machinery Room (1-111-1-Q) by manually lifting the plungers located on top of the FM-200 pressure switches, or by shutdowns that will occur automatically during FM-200 system actuation.

Ensure the following Powered Ventilation systems are secured:

- Engine Room Supply Fan SF-1 Port
- Engine Room Supply Fan SF-2 Stbd.
- Engine Room Exhaust Fan EF-1 Port
- Engine Room Exhaust Fan EF-2 Stbd.

Secure the following Diesel Engines are secured:

- Ships Service Diesel Generator No. 1
- Ships Service Diesel Generator No. 2
- Main Engine Port
- Main Engine Starboard

**NOTE**

**Upon automatic shutdown of ships service generators, the emergency diesel generator set will automatically start and place itself on line within 45 seconds.**

Secure the following openings to the protected space:

OPENING	LOCATION
Port Engine Room Supply Fan Intake Damper	Main Deck Weather Area (1-0-0-WEA), Frame 28
Stbd Engine Room Supply Fan Intake Damper	Main Deck Weather Area (1-0-0-WEA), Frame 28
Engine Room Entrance Door	Main Deck Passageway (1-33-0-L), Frame 41
Engine Room Escape Scuttle	Main Deck Weather Area (1-0-0-WEA), Port Side, Frame 27

Tunnel Watertight Door	Below Main Deck, Starboard Side, Watertight Bulkhead 25
Tunnel Vent Watertight Closure (Aft P/S)	Below Main Deck, Watertight Bulkhead 25
Tunnel Supply Fan SF-3 Cover	Main Deck Weather Area (1-0-0-WEA), Port Side, Bulwark, Frame 28
Air Cond. Unit – Fire Damper No. 7	Emergency Generator Room, Port Side, Above Emergency Switchboard

**REMEMBER – An actual fire emergency is not the time to train to perform these procedures!**

**NOTE**

**The responsibilities to perform these space preparations listed above have been identified on the LCU-2K station bill for fire and damage control conditions and crew members should routinely train for these responsibilities.**

- (4) Break Glass On FM-200 Pull Station. Initiate actuating the FM-200 fixed fire fighting system for the Engine Room by breaking the glass for access to the pull handle.

Pull Stations are found in the following areas:

**NOTE**

**Actual location may vary slightly between vessels.**

- (a) Engine Room Interior Remote FM-200 Pull Station located in the Passageway (1-33-0-L), Main Deck Level, Frame 41.
  - (b) Engine Room Exterior Remote FM-200 Pull Station located on the Main Deck Weather Area (1-0-0-WEA), Port Side, watertight bulkhead 28. This exterior Watertight pull station requires first opening the watertight cover to expose the glass.
- (5) Pull Lever On FM-200 Pull Station. Actuate the FM-200 system by pulling the handle. The lever requires less than 40 pounds force and 6 inches of pull to operate. Allow no one to enter the protected space until authorized to do so.

**WARNING**

**In the event the FM-200 system electric horn/strobe or warning lights (amber strobe) are activated, leave the protected space immediately.**

**FM-200 is being released within 60 seconds, death or serious injury could occur.**

**NOTE**

**Upon actuation of the FM-200 Fire Extinguishing System, a sixty (60) second time delay before agent discharge will be experienced. During this delay, FM-200 system electric horn/strobe will sound, FM-200 warning bell will sound continuously and the FM-200 warning lights (amber strobe) will be illuminated.**

As a fail safe mode, actuation of the FM-200 Fixed Fire Extinguishing System will result in the automatic shutdown of the following machinery, equipment and powered ventilation system motors affecting the protected space.

**MACHINERY/EQUIPMENT**

Ships Service Diesel Generator No. 1 Stbd.  
Ships Service Diesel Generator No. 2 Port  
Main Propulsion Engine Port  
Main Propulsion Engine Stbd.

**VENTILATION SYSTEMS**

Engine Room Supply Fan SF-1 Port  
Engine Room Supply Fan SF-2 Starboard  
Engine Room Exhaust Fan EF-1 Port  
Engine Room Exhaust Fan EF-2 Starboard

**NOTE**

Upon automatic shutdown of ships service generators, the emergency diesel generator set will automatically start and place itself on line within 45 seconds.

**NOTE**

Engine room exhaust fan EF-1 port and engine room exhaust fan EF-2 starboard ventilation system openings are each fitted with a gravity operated louver which closes automatically when engine room exhaust fans are secured.

If FM-200 system fails to operate, proceed to the CO<sup>2</sup> Control Cylinder located in A/C and Emergency Generator Room (1-43-0-E), Frame 44 and follow Local Manual Release Instructions posted at the CO<sup>2</sup> cylinder location.

**WARNING**

The FM-200 system has been outfitted with a time delay override located on top of the time delay.

**When the time delay override lever is pulled, the 60 second time delay is negated and FM-200 will immediately discharge into the protected spaces.**

This procedure should only be performed under extreme circumstances and with the authority of the watch officer or scene commander.

Failure to adhere to these warnings could result in death or serious injury.

If FM-200 system fails to operate, proceed to Emergency Discharge Instructions posted at the Engine Room FM-200 cylinder location, A/C and Emergency Generator Room (1-43-0-E), Frame 43 or the Emergency Discharge Instructions posted at the MCC Area FM-200 cylinder location, Tunnel (3-17-0-Q), Frame 24 and follow Emergency Discharge Instructions.

**NOTE**

Emergency discharge actuation of engine room and MCC area FM-200 cylinder banks can be accomplished simultaneously at the emergency discharge release for either engine room or MCC area FM-200 cylinder bank.

If operating in this Emergency Release Mode, the operator should check that both the cylinder banks have discharged by observing the pressure gage readings on the individual cylinders.

## WARNINGS

**Actuation of the FM-200 System in the emergency discharge mode will result in bypassing of the 60 second time delay and pressure switches. The automatic equipment shutdowns, electric horn/strobe, warning lights (amber strobe), and warning bell will not function. FM-200 will be discharged immediately.**

**Operate the pressure switches by manually lifting the plunger located on the top of the pressure switches to shutdown equipment. Failure to observe these warnings could result in death or serious injury.**

**To reduce temperatures within the protected space and manage the risk of HF exposure to humans, the WWS is designed and intended to be operated for a minimum of 15 minutes. This procedure should be followed to the full extent or death or serious injury could occur.**

## NOTE

**The engine room FM-200 system is augmented with an installed WWS. If necessary, the FM-200 system could be used as a stand alone system.**

Operate the WWS for a minimum of fifteen (15) minutes. During the WWS operating period, approximately every three (3) minutes, open valve WWS-2, Engine Room WWS Strainer Blow Off for approximately ten (10) seconds. This will allow any foreign matter to be flushed from the strainer basket.

- c. Actuation Procedures, Tunnel FM-200 System. All fire scenarios and situations leading to the decision when to actuate the FM-200 total flooding fire extinguishing system are not intended to be discussed here. Refer to the US Army Fire Fighting Doctrine for guidance. However, the following steps must be completed to effectively deploy the FM-200 system as designed.

In the event the FM-200 Fixed Fire Fighting System is to be actuated, the following steps must be accomplished prior to actuation of the system.

## WARNING

**In the event the FM-200 System electric horn/strobe or warning lights (amber strobe) are activated, leave the protected space immediately.**

**FM-200 is being released within 60 seconds, death or serious injury could occur.**

- (1) Evacuate All Personnel From Space. The Watch Officer or on-scene commander must ensure all personnel have evacuated the space and are accounted for.
- (2) Activate The Water Washdown System (WWS). In order to operate the WWS, the fire main system must be charged. Ensure that the two (2) engine room fire pumps are placed on line at the maximum operating pressure.



**WARNING**

The Water Washdown System (WWS), installed to augment the tunnel FM-200 System, shall be activated prior to actuation of the FM-200 Fixed Fire Extinguishing System.

To provide adequate flow of seawater to the tunnel, the (2) engine room fire pumps must be operated at a minimum pressure of 96 psi.

During operation of the WWS, sufficient fire main capacity exists for four (4) 1 ½” fire hoses at full stream or nine (9) 1 ½” hoses at spray.

Failure to operate engine room fire pumps at 96 psi could result in equipment damage or serious injury to personnel.

The WWS should always be ready to immediately deploy by disengaging the locking mechanism on the ball valve handle. Pad locking of this handle should only occur during system maintenance or equipment damage, death or serious injury could occur.

Activate the WWS by unlocking and opening valve WWS-1, Tunnel WWS Control Station, located in the Engine Room (3-25-0-E), Starboard side, watertight bulkhead 25. Refer to paragraph 2-64 for operation of the Water Washdown System (WWS).

- (3) Secure Ventilation. Secure powered ventilation to the protected space. This can be accomplished locally at the motor-controller if the situation allows during the evacuation process, at the FM-200 Storage Cylinders located in the Engine Room MCC Area by manually lifting the plunger located on top of the FM-200 pressure switch, or by shutdowns that will occur automatically during FM-200 system actuation.

Ensure the following Powered Ventilation system is secured: Tunnel Supply Fan SF-3.

**REMEMBER – An actual fire emergency is not the time to train to perform these procedures!**

Secure the following openings to the protected space:

**NOTE**

The responsibilities to perform these space preparations listed have been identified on the LCU-2K station bill for fire and damage control conditions and crew members should routinely train for these responsibilities

OPENING	LOCATION
Tunnel Supply Fan SF-3 Cover	Main Deck Weather Area (1-0-0-WEA), Port Side Bulwark, Frame 28
Tunnel Vent Watertight Closure (Aft P/S)	Below Main Deck, Watertight Bulkhead 25
Tunnel Vent Watertight Closure (Fwd)	Below Main Deck, Starboard Side, Watertight Bulkhead 17
Tunnel Watertight Door	Below Main Deck, Starboard Side, Watertight Bulkhead 25

Bow Thruster Room Watertight Door	Below Main Deck, Starboard Side, Watertight Bulkhead 17
-----------------------------------	---

- (4) Break glass on FM-200 pull station.

#### NOTE

**Actual location may vary slightly between vessels.**

Initiate actuating the FM-200 fixed fire fighting system for the tunnel by breaking the glass for access to the pull handle.

Pull Stations are found in the following areas:

- (a) Tunnel Interior Remote FM-200 Pull Station located in the Engine Room (3-25-0-E), starboard side, watertight bulkhead 25.
  - (b) Tunnel Exterior Remote FM-200 Pull Station located on the Main Deck Weather Area (1-0-0-WEA) port side, watertight bulkhead 28. This exterior watertight pull station requires first opening the watertight cover to expose the glass.
- (5) Pull lever on FM-200 pull station. Actuate the FM-200 system by pulling the handle. The lever requires less than 40 pounds force and 6 inches of pull to operate. Allow no one to enter the protected space until authorized to do so.

#### WARNING

**In the event the FM-200 system electric horn/strobe or warning lights (amber strobe) are activated, leave the protected space immediately. FM-200 is being released within 60 seconds, death or serious injury could occur.**

#### NOTE

**Upon actuation of the FM-200 fire extinguishing system, a sixty (60) second time delay before agent discharge will be experienced. During this delay, FM-200 system electric horn/strobe will sound, FM-200 warning bell will sound continuously and the FM-200 warning light (amber strobe) will be illuminated.**

As a fail safe mode, actuation of the FM-200 Fixed Fire Extinguishing system will result in the automatic shutdown of the following powered ventilation system motor affecting the protected space.

Tunnel Supply Fan SF-3

If FM-200 system fails to operate, proceed to the CO<sup>2</sup> Control Cylinder located in the Engine Room (3-25-0-E), Frame 25 and follow Local Manual Release Instructions posted at the CO<sup>2</sup> cylinder location.

**WARNING**

The FM-200 system has been outfitted with a time delay override located on top of the time delay.

**When the time delay override lever is pulled, the 60 second time delay is negated and FM-200 will immediately discharge into the protected spaces.**

This procedure should only be performed under extreme circumstances and with the authority of the watch officer or scene commander.

Failure to observe these warnings could result in death or serious injury.

Operate the WWS for a minimum of fifteen (15) minutes. During the WWS operating period, approximately every three (3) minutes, open valve WWS-2, Tunnel WWS Strainer Blow Off for approximately ten (10) seconds. This will allow foreign matter to be flushed from the strainer basket.

**WARNING**

To reduce temperatures within the protected space and manage the risk of HF exposure to humans, the WWS is designed and intended to be operated for a minimum of 15 minutes. This procedure should be followed to the full extent or death or serious injury could occur.

**NOTE**

The tunnel FM-200 System is augmented with an installed WWS. If necessary, the FM-200 System could be used as a stand alone system.

- d. Actuation Procedures, Bow Thruster Room FM-200 System. All fire scenarios and situations leading to the decision when to actuate the FM-200 total flooding fire extinguishing system are not intended to be discussed here. Refer to the US Army Fire Fighting Doctrine for guidance. However, the following steps must be completed to effectively deploy the FM-200 System as designed.

In the event the FM-200 Fixed Fire Fighting System is to be actuated, the following steps must be accomplished prior to actuation of the system.

**WARNING**

**In the event the FM-200 System electric horn/strobe or warning lights (amber strobe) are activated, leave the protected space immediately. FM-200 is being released within 60 seconds, death or serious injury could occur.**

- (1) Evacuate All Personnel From Space. The Watch Officer or on-scene commander must ensure all personnel have evacuated the space and are accounted for.
- (2) Activate the Water Washdown System (WWS). In order to operate the WWS, the fire main system must be charged. Ensure that the two (2) Engine Room Fire Pumps are placed on line to the maximum operating pressure.

**WARNING**

The water washdown system (WWS), installed to augment the bow thruster room FM-200 System, shall be activated prior to actuation of the FM-200 Fixed Fire Extinguishing System.

During operation of the WWS, sufficient fire main capacity of one (1) engine room fire pump exists for two (2) 1 ½” fire hoses at full stream or four (4) 1 ½” hoses at spray.

During operation of the WWS, sufficient fire main capacity of two (2) engine room fire pumps exists for four (4) 1 ½” fire hoses at full stream or nine (9) 1 ½” hoses at spray.

To provide adequate flow of seawater to the bow thruster room WWS, the engine room fire pumps must be operated at a minimum pressure of 91 psi or equipment damage, death or serious injury could occur.

**CAUTION**

The WWS should always be ready to immediately deploy by disengaging the locking mechanism on the ball valve handle. Pad locking of this handle should only occur during system maintenance or equipment damage, death or serious injury could occur.

Activate the WWS by unlocking and opening valve WWS-1, Bow Thruster Room WWS Control Station, located in the Tunnel (3-17-0-Q), Starboard side, watertight bulkhead 17. Refer to paragraph 2-64 for operation of the Water Washdown System (WWS).

- (3) Secure Ventilation. Secure powered ventilation to the protected space. This can be accomplished locally at the motor-controller if the situation allows during the evacuation process, at the FM-200 Storage Cylinders located in the tunnel by manually lifting the plungers located on top of the FM-200 pressure switches or by shutdowns that will occur automatically during FM-200 system actuation.

Ensure the following Powered Ventilation system is secured: Bow Thruster Room Supply Fan

Ensure the following Diesel Engine is secured: Bow Thruster Diesel Engine

Secure the following openings to the protected space:

OPENING	LOCATION
Bow Thruster Room Power Vent Supply Cover	Main Deck Weather Area (1-0-0-WEA), Port Side, Frame 9
Bow Thruster Room Natural Vent Exhaust Cover	Main Deck Weather Area (1-0-0-WEA), Starboard Side, Frame 9
Bow Thruster Room Escape Scuttle	Forecastle Deck Weather Area (01-0-1-WEA), Starboard Side, Frame 9
Bow Thruster Room Watertight Door	Below Main Deck, Starboard Side, Water-Tight Bulkhead 17
Tunnel Vent Watertight Closure (Fwd)	Below Main Deck, Starboard Side, Water-Tight Bulkhead 17

**REMEMBER – An actual fire emergency is not the time to train to perform these procedures!**

**NOTE**

**The responsibilities to perform the space preparations listed have been identified on the LCU-2K station bill for fire and damage control conditions and crew members should routinely train for these responsibilities.**

- (4) Break glass on FM-200 pull station. Initiate actuating the FM-200 fixed fire fighting system for the Bow Thruster Room by breaking the glass for access to the pull handle.

Pull Stations are found in the following areas:

**NOTE**

**Actual location may vary slightly between vessels.**

- (a) Bow Thruster Room Interior Remote FM-200 Pull Station located in the Tunnel (3-17-0-Q), Starboard side, watertight bulkhead 17.
  - (b) Bow Thruster Room Exterior Remote FM-200 Pull Station located on the Main Deck Weather Area (1-0-0-WEA), Port side, watertight bulkhead 28. This exterior watertight pull station requires first opening the watertight cover to expose the glass.
- (5) Pull lever on FM-200 pull station. Actuate the FM-200 system by pulling the handle. The lever requires less than 40 pounds force and 6 inches of pull to operate. Allow no one to enter the protected space until authorized to do so.

**WARNING**

**In the event the FM-200 System electric horn/strobe or warning lights (amber strobe) are activated leave the protected space immediately. FM-200 is being released within 60 seconds, death or serious injury could occur.**

**NOTE**

**Upon actuation of the FM-200 fire extinguishing system, a sixty (60) second time delay before agent discharge will be experienced. During this delay, FM-200 system electric horn/strobe will sound, FM-200 warning bell will sound continuously and the FM-200 warning light (amber strobe) will be illuminated.**

As a fail safe mode, actuation of the FM-200 Fixed Fire Extinguishing system will result in the automatic shutdown of the following machinery, equipment and powered ventilation system motors affecting the protected space.

**Machinery**

Bow Thruster Diesel Engine

**Ventilation System**

Bow Thruster Room Supply Fan

If FM-200 system fails to operate, proceed to the CO<sup>2</sup> Control Cylinder located in the tunnel (0-17-0-Q), Frame 20 and follow Local Manual Release Instructions posted at the CO<sup>2</sup> cylinder location.

**WARNING**

The FM-200 system has been outfitted with a time delay override located on top of the time delay.

**When the time delay override lever is pulled, the 60 second time delay is negated and FM-200 will immediately discharge into the protected spaces.**

**This procedure should only be performed under extreme circumstances and with the authority of the watch officer or scene commander.**

**Failure to observe these warnings could result in serious injury or death.**

Operate the WWS for a minimum of fifteen (15) minutes. During the WWS operating period, approximately every three (3) minutes, open valve WWS-2, Bow Thruster Room WWS Strainer Blow Off for approximately ten (10) seconds. This will allow any foreign matter to be flushed from the strainer basket.

**WARNING**

**To reduce temperatures within the protected space and manage the risk of HF exposure to humans, the WWS is designed and intended to be operated for a minimum of 15 minutes. This procedure should be followed to the full extent or death or serious injury could occur.**

**NOTE**

**The bow thruster room FM-200 system is augmented with an installed WWS. If necessary, the FM-200 system could be used as a stand alone system.**

- e. Actuation Procedures, Paint Locker FM-200 System. All fire scenarios and situations leading to the decision when to actuate the FM-200 total flooding fire extinguishing system are not intended to be discussed here. Refer to the US Army Fire Fighting Doctrine for guidance. However, the following steps must be completed to effectively deploy the FM-200 system as designed.

In the event the FM-200 Fixed Fire Fighting System is to be actuated, the following steps must be accomplished prior to activation of the system.

**WARNING**

**To reduce temperatures within the protected space and manage the risk of HF exposure to humans, the WWS is designed and intended to be operated for a minimum of 15 minutes. This procedure should be followed to the full extent or death or serious injury could occur.**

- (1) Evacuate all personnel from space. The Watch Officer or on-scene commander must ensure all personnel have evacuated the space and are accounted for.

- (2) Secure Ventilation. Secure powered ventilation to the protected space. This can be accomplished locally at the motor-controller if the situation allows during the evacuation process, at the FM-200 storage cylinder located in the bow thruster room by manually lifting the plunger located on top of the FM-200 pressure switch, or by shutdowns that occur automatically during FM-200 system actuation.

Ensure the following powered ventilation systems are secured:

Paint Locker Supply Fan SF-3

Secure the following openings to the protected space:

OPENING	LOCATION
Paint Locker Natural Supply Cover	Main Deck Weather Area (1-0-0-WEA), Port Side, Frame 5
Paint Locker Powered Exhaust Vent Cover	Main Deck Weather Area (1-0-0-WEA), Port Side, Frame 12
Paint Locker Watertight Door	Main Deck, Port Side, Watertight Bulkhead 13

**REMEMBER – An actual fire emergency is not the time to train to perform these procedures!**

**NOTE**

**The responsibilities to perform these space preparations listed above have been identified on the LCU-2K station bill for fire and damage control conditions and crew members should routinely train for these responsibilities.**

- (3) Break Glass On FM-200 Pull Station. Initiate actuating the FM-200 fixed fire fighting system for the paint locker by breaking the glass for access to the pull handle.

The pull station is found in the following area:

**NOTE**

**Actual location may vary slightly between vessels.**

Paint locker pull station located on the exterior of the paint locker aft bulkhead, main deck weather area (1-0-0-WEA), watertight bulkhead 13. This exterior watertight pull station requires first opening the watertight cover to expose the glass.

- (4) Pull Lever On FM-200 Pull Station. Actuate the FM-200 system by pulling the handle. The lever requires less than 40 pounds force and 6 inches of pull to operate. Allow no one to enter the protected space until authorized to do so.

**WARNING**

**The paint locker FM-200 system is not fitted with a time delay. Upon actuation of FM-200 system, siren will sound for approximately 10 seconds and FM-200 will be discharged immediately. The warning bell will sound until manually reset.**

**In the event the FM-200 system siren or warning bell is activated, always leave the protected space immediately. FM-200 is being released, death or serious injury could occur.**

As a fail safe mode, actuation of the FM-200 fixed fire extinguishing system will result in the automatic shutdown of the following powered ventilation system motor affecting the protected space.

Paint Locker Powered Exhaust Fan

If FM-200 system fails to operate, proceed to the Paint Locker FM-200 Cylinder, located in the bow thruster room (3-5-0-E), frame 10 and follow local manual release instructions posted at the FM-200 cylinder.

- f. Actuation Procedures, A/C and Emergency Generator Room FM-200 System. All fire scenarios and situations leading to the decision when to actuate the FM-200 total flooding fire extinguishing system are not intended to be discussed here. Refer to the US Army Fire Fighting Doctrine for guidance. However, the following steps must be completed to effectively deploy the FM-200 system as designed.

In the event the FM-200 Fixed Fire Fighting System is to be actuated, the following steps must be accomplished prior to activation of the system.

**WARNING**

**In the event the FM-200 system electric horn/strobe or warning lights (amber strobe) are activated, leave the protected space immediately.**

**FM-200 is being released within 60 seconds, death or serious injury could occur.**

- (1) Evacuate All Personnel From Space. The Watch Officer or on-scene commander must ensure all personnel have evacuated the space and are accounted for.
- (2) Secure Ventilation. Secure powered ventilation system to the protected space. This can be accomplished locally at the motor-controller if the situation allows during the evacuation process, at the FM-200 storage cylinder located in the stowage locker by manually lifting the plungers located on top of the FM-200 pressure switches, or by shutdowns that will occur automatically during FM-200 system actuation.

Ensure the following Powered Ventilation systems are secured:

A/C and Emergency Generator Room Supply Fan

Ensure the following Diesel Engines are secured:

Emergency Generator Diesel Engine

Secure the following openings to the protected space:

OPENING	LOCATION
Emergency Generator Exhaust Cover	Main Deck Weather Area (1-28-3-WEA), Starboard Side, Frame 52
Air Conditioning Vent Plenum Cover	Main Deck Weather Area (1-28-3-WEA), Starboard Side, Frame 49
Power Supply Cover	Main Deck Weather Area (1-28-3-WEA), Starboard Side, Frame 52
Natural Air Intake Cover	Main Deck Weather Area (1-28-3-WEA), Starboard Side, Frame 49



**REMEMBER – An actual fire emergency is not the time to train to perform these procedures!**

**NOTE**

**The responsibilities to perform these space preparations listed above have been identified on the LCU-2K station bill for fire and damage control conditions and crew members should routinely train for these responsibilities.**

- (3) Break Glass On FM-200 Pull Station. Initiate actuating the FM-200 fixed fire fighting system for the A/C and Emergency Generator Room by breaking the glass for access to the pull handle.

The pull station is found in the following area:

**NOTE**

**Actual location may vary slightly between vessels.**

A/C and Emergency Generator Room FM-200 Pull Station located in the passageway (1-33-0-L), Main Deck Level, Starboard Side, Frame 46.

- (4) Pull Lever On FM-200 Pull Station. Actuate the FM-200 system by pulling the handle. The lever requires less than 40 pounds force and 6 inches of pull to operate. Allow no one to enter the protected space until authorized to do so.

**WARNING**

**In the event the FM-200 system electric horn/strobe or warning lights (amber strobe) are activated leave the protected space immediately.**

**FM-200 is being released within 60 seconds, death or serious injury could occur.**

**NOTE**

**Upon actuation of the FM-200 fire extinguishing system, a 60 second delay in agent discharge will be experienced. During this delay, FM-200 system electric horn/strobe will sound, FM-200 system warning bell will sound continuously and the FM-200 discharge warning light will be illuminated.**

As a fail safe mode, actuation of the FM-200 Fixed Fire Extinguishing system will result in the automatic shutdown of the following machinery, equipment and powered ventilation system motors affecting the protected space.

**MACHINERY**

**VENTILATION SYSTEMS**

Emergency Generator Diesel Engine    A/C & Emergency Generator Room Supply Fan

If FM-200 system fails to operate, proceed to the A/C and Emergency Generator Room CO<sup>2</sup> cylinder, located in the Stowage Locker (1-43-1-Q), Frame 44 and follow Local Operation Instructions posted at the CO<sup>2</sup> cylinder location.

**WARNING**

**The FM-200 system has been outfitted with a time delay override located on top of the time delay.**

**When the time delay override lever is pulled, the 60 second time delay is negated and FM-200 will immediately discharge into the protected spaces.**

**This procedure should only be performed under extreme circumstances and with the authority of the Watch Officer or Scene Commander. Failure to observe these warnings could result in death or serious injury.**

g. System Safety.

## (1) Nature and Characteristics of FM-200.

- Suppresses fire by a combination of chemical and physical mechanisms without affecting available oxygen.
- Designed for use on Class A (cellulose material), Class B (flammable liquids) and Class C (energized electrical equipment) fires.
- Hydro fluorocarbon (HFC) family (HFC-227ea).
- Trade Name: FM-200.
- Zero Ozone Depleting Potential.
- Fast Action: Discharge within 10 seconds.
- Clean: Discharges as a gas, leaves no residue to damage sensitive equipment.
- People safe in case of unintentional discharge in the protected space.
- Propelled by Nitrogen gas.
- Predischarge (actuation) controlled by CO<sup>2</sup> (Engine Room, Tunnel, Bow Thruster, A/C Machinery Room systems only).

(2) FM-200 Toxicity Data. FM-200 has acceptable toxicity for use in occupied spaces when used as specified in the US Environmental Protection Agency (EPA) Significant New Alternatives Policy (SNAP) program rules. Although FM-200 is considered non-toxic to humans in concentrations necessary to extinguish most fires, certain safety considerations should be observed when applying and handling the agent. The discharge of FM-200 may create a hazard to personnel from the undecomposed agent itself and from the decomposition products which result when the agent is exposed to fire and other hot surfaces at temperatures above 1300°F. Exposure to the FM-200 agent is generally of less concern than is exposure to the decomposition products. Unnecessary exposure to the agent or decomposition products should be avoided.

(3) Hydrogen Fluoride (HF) Gas. FM-200, when exposed to fire or other hot surfaces at temperatures above 1300°F, will produce HF Gas. Over exposure to HF Gas, in concentrations greater than three (3) parts per million (ppm), will have the following effects on humans:

- Corrosive and irritating to the eyes.
- Corrosive and irritating to skin and all living tissue.
- When ingested, corrosive and irritating to the gastrointestinal system.
- When inhaled, corrosive and irritating to upper and lower respiratory tract; may result in chemical pneumonitis and pulmonary Edema which could be fatal.

(4) Material Safety Data Sheet (MSDS). The MSDS for HF Gas and other chemicals used in the installed FM-200 systems are identified and provided as follows:

MSDS	LOCATION
Hydrogen Fluoride (HF) Gas	TM 55-1905-243-24&P
FM-200	TM 55-1905-243-24&P
Nitrogen	TM 55-1905-243-24&P
Carbon Dioxide (CO <sup>2</sup> ) Gas	TM 55-1905-243-24&P

(5) Combating HF Gas. In order to combat HF Gas, the below main deck machinery spaces (engine room, tunnel and bow thruster room) have been fitted with individual Water Washdown Systems (WWS). Reference paragraph 2-64 for WWS operation. The design and maintenance requirements for the WWS are contained in TM 55-1905-243-24&P. The purpose of the WWS is to:

- Quickly reduce temperature in the protected space.
- Minimize production of HF Gas generated as a result of FM-200 agent decomposition from contact with hot surfaces and flame at temperatures above 1300°F.
- Aid in scrubbing of any HF Gas generated.
- Expedite ventilation of the protected space.

(6) Oxygen Breathing Apparatus (OBA) and Fire Fighting Equipment. HF Gas damages aluminum, kevlar and metal components. **OBA and Fire Fighting Equipment, when exposed to HF Gas, shall be taken out of service until affected components are replaced.**

h. Post Fire Re-Entry.

Authorization to re-enter the engine room, tunnel, bow thruster room, paint locker or A/C and emergency generator room, after discharge of the FM-200 fixed fire extinguishing system and WWS, shall be issued by the person in charge at the scene.

i. Re-Entry Testing Requirements.

**WARNING**

**Dependent upon the temperature of the fire within the protected space prior to extinguishment, the protected space may contain a level of HF Gas which is dangerous to humans. Testing to verify that the level of HF Gas is safe for re-entry must be performed and followed to the full extent of the re-entry testing procedures for HF Gas contained in manufacturer's operation and maintenance instructions. The protected space shall not be entered unprotected when the level of HF Gas has a threshold limit value (TLV) of three (3) parts per million (PPM) or greater.**

**If HF Gas reading is above 3 PPM, continue to operate the water washdown system and follow testing procedures until level is safe for re-entry. For those spaces without an installed water washdown system, the natural decay (drop out) rate for HF gas is approximately 15 minutes after the fire is extinguished. Failure to follow these procedures could result in death or serious injury.**

(1) Testing Prior To Re-Entering Engine Room. Prior to re-entry into the Engine Room, after discharge of the FM-200 fixed fire extinguishing system, the protected space shall be tested for levels of HF gas. An HF Gas Sampling Port has been installed to facilitate testing. The HF Gas Sampling Port for the Engine Room is located in the

Water Washdown Control Station, Main Deck Starboard Passageway (1-33-0-L), Frame 41. Testing for levels of HF gas shall be accomplished using the sampling pump which has been issued at the time of FM-200 system installations. Maintenance instructions for the sampling pump are contained in TM 55-1905-243-24&P. A minimum of three (3) samples at two (2) minute intervals shall be taken.

#### WARNING

**Dependent upon the temperature of the fire within the protected space prior to extinguishment, the protected space may contain a level of HF Gas which is dangerous to humans. Testing to verify that the level of HF Gas is safe for re-entry must be performed and followed to the full extent of the re-entry testing procedures for HF Gas contained in manufacturer's operation and maintenance instructions. The protected space shall not be entered unprotected when the level of HF Gas has a threshold limit value (TLV) of three (3) parts per million (PPM) or greater.**

**If HF Gas reading is above 3 PPM, continue to operate the water washdown system and follow testing procedures until level is safe for re-entry. For those spaces without an installed water washdown system, the natural decay (drop out) rate for HF gas is approximately 15 minutes after the fire is extinguished. Failure to follow these procedures could result in death or serious injury.**

- (2) Testing Prior to Re-Entering Tunnel. Prior to re-entry into the tunnel, after discharge of the FM-200 fixed fire extinguishing system, the protected space shall be tested for levels of HF gas. An HF Gas sampling port has been installed to facilitate testing. The HF Gas sampling port for the tunnel is located in the Water Washdown Control Station, Engine Room (0-25-0-E), watertight bulkhead 25. Testing for levels of HF gas shall be accomplished using the sampling pump which has been issued at the time of FM-200 system installations. Reference maintenance instructions in TM 55-1905-243-24&P, Detector Tubes and Kwik-Draw Pumps. A minimum of three (3) samples at two (2) minute intervals shall be taken.

#### WARNING

**Dependent upon the temperature of the fire within the protected space prior to extinguishment, the protected space may contain a level of HF gas which is dangerous to humans. Testing to verify that the level of HF gas is safe for re-entry must be performed and followed to the full extent of the re-entry testing procedures for HF gas contained in manufacturer's operation and maintenance instructions. The protected space shall not be entered unprotected when the level of HF gas has a threshold limit value (TLV) of three (3) parts per million (PPM) or greater. If HF gas reading is above 3 PPM, continue to operate the Water Washdown System and follow testing procedures until level is safe for re-entry. For those spaces without an installed Water Washdown System, the natural decay (drop out) rate for HF gas is approximately 15 minutes after the fire is extinguished. Failure to observe these precautions could result in death or serious injury.**

- (3) Testing Prior to Re-Entering Bow Thruster Room. Prior to re-entry into the Bow Thruster Room, after discharge of the FM-200 fixed fire extinguishing system, the protected space shall be tested for levels of HF gas. An HF Gas Sampling Port has been installed to facilitate testing. The HF Gas Sampling Port for the Bow Thruster Room is located in the Water Washdown Control Station, Tunnel (3-17-0-Q), Starboard side, watertight bulkhead 17. Testing for levels of HF gas shall be accomplished using the Sampling Pump which has been

issued at the time of FM-200 system installations. Maintenance instructions for the Sampling Pump are contained in TM 55-1905-243-24&P. A minimum of three (3) samples at two (2) minute intervals shall be taken.

#### **WARNING**

**Dependent upon the temperature of the fire within the protected space prior to extinguishment, the protected space may contain a level of HF gas which is dangerous to humans. Testing to verify that the level of HF gas is safe for re-entry must be performed and followed to the full extent of the re-entry testing procedures for HF gas contained in manufacturer's operation and maintenance instructions. The protected space shall not be entered unprotected when the level of HF gas has a threshold limit value (TLV) of three (3) parts per million (PPM) or greater.**

**If HF gas reading is above 3 PPM, continue to operate the Water Washdown System and follow testing procedures until level is safe for re-entry. For those spaces without an installed Water Washdown System, the natural decay (drop out) rate for HF gas is approximately 15 minutes after the fire is extinguished. Failure to observe these precautions could result in death or serious injury.**

- (4) Testing Prior to Re-entering Paint Locker. Prior to re-entry into the Paint Locker, after discharge of the FM-200 fixed fire extinguishing system, the protected space shall be tested for levels of HF gas. An HF gas sampling port has been installed to facilitate testing. The HF gas sampling port for the paint locker is located on the aft, exterior bulkhead of the paint locker, frame 13. Testing for levels of HF gas shall be accomplished using the sampling pump which has been issued at the time of FM-200 system installations. Maintenance instructions for the sampling pump are contained in TM 55-1905-243-24&P. A minimum of three (3) samples at two (2) minute intervals shall be taken.

#### **WARNING**

**Dependent upon the temperature of the fire within the protected space prior to extinguishment, the protected space may contain a level of HF gas which is dangerous to humans. Testing to verify that the level of HF gas is safe for re-entry must be performed and followed to the full extent of the re-entry testing procedures for HF gas contained in manufacturer's operation and maintenance instructions. The protected space shall not be entered unprotected when the level of HF gas has a threshold limit value (TLV) of three (3) parts per million (PPM) or greater.**

**If HF gas reading is above 3 PPM, continue to operate the Water Washdown System and follow testing procedures until level is safe for re-entry. For those spaces without an installed Water Washdown System, the natural decay (drop out) rate for HF gas is approximately 15 minutes after the fire is extinguished. Failure to observe these precautions could result in death or serious injury.**

- (5) Testing Prior to Re-entering, A/C and Emergency Generator Room. Prior to re-entry into the A/C and emergency generator room, after discharge of the FM-200 fixed fire extinguishing system, the protected space shall be tested for levels of HF gas. An HF gas sampling port has been installed to facilitate testing. The HF gas sampling port for the A/C and emergency generator room transverse bulkhead, Frame 46. Testing for levels of HF

gas shall be accomplished using the sampling pump which has been issued at the time of FM-200 system installations. Maintenance instructions for the sampling pump are contained in TM 55-1905-243-24&P. A minimum of three (3) samples at two (2) minute intervals shall be taken.

j. Re-Entry

- (1) Engine Room Re-Entry Procedures. Upon issuance of re-entry authorization by the person in charge at the scene and authorization to ventilate space, the following actions shall be taken:

- Open Port and Starboard Engine Room Supply Fan openings
- Reset Plunger on Pressure Switches

**NOTE**

**FM-200 pressure switches must be manually reset by pushing down on the plunger, on top of pressure switch. Plunger must be returned to "set" position to reactivate all systems shutdown by pressure switch.**

- Start all available powered ventilation within the protected space
- Washdown complete interior and all equipment, within the protected space with fresh water.

- (2) Tunnel Re-Entry Procedures. Upon issuance of re-entry authorization by the person in charge at the scene and authorization to ventilate space, the following actions shall be taken:

- Open tunnel supply fan opening
- Open tunnel vent watertight closures openings (3)
- Reset pressure switch plunger

**NOTE**

**FM-200 pressure switches must be manually reset by pushing down on the plunger, on top of pressure switch. Plunger must be returned to "set" position to reactivate all systems shutdown by pressure switch.**

- Start all available powered ventilation within the protected space
- Washdown complete interior and all equipment, within the protected space, with fresh water

- (3) Bow Thruster Room Re-Entry Procedures. Upon issuance of re-entry authorization by the person in charge at the scene and authorization to ventilate, the following actions shall be taken:

- Open bow thruster room supply and exhaust vent opening
- Reset plunger on pressure switches

**NOTE**

**FM-200 pressure switches must be manually reset by pushing down on the plunger, on top of pressure switch. Plunger must be returned to "set" position to reactivate all systems shutdown by pressure switch.**

- Start all available powered ventilation within the protected space
- Washdown complete interior and all equipment, within the protected space, with fresh water.

(4) Paint Locker Re-Entry Procedures. Upon issuance of re-entry authorization by the person in charge at the scene and authorization to ventilate, the following actions shall be taken:

- Open paint locker supply and exhaust vent openings
- Reset pressure switch plunger.

**NOTE**

**FM-200 pressure switches must be manually reset by pushing down on the plunger, on top of pressure switch. Plunger must be returned to “set” position to reactivate all systems shutdown by pressure switch.**

- Open paint locker door and ventilate space using portable, powered ventilation
- Washdown complete interior and all equipment, within the protected space, with fresh water

(5) A/C and Emergency Generator Room Re-entry Procedures. Upon issuance of re-entry authorization by the person in charge at the scene and authorization to ventilate, the following actions shall be taken:

- Remove the following ventilation covers:
  - A/C and Emergency Generator Room Supply Fan
  - A/C and Emergency Generator Room Natural Air Intake
  - Air Conditioning Vent Plenum
  - Emergency Generator Exhaust
- Reset plunger on pressure switches

**NOTE**

**FM-200 pressure switches must be manually reset by pushing down on the plunger, on top of pressure switch. Plunger must be returned to “set” position to reactivate all systems shut down by pressure switch.**

- Start all available powered ventilation within the protected space.
- Washdown complete interior and all equipment, within the protected space, with fresh water.

k. Bilge Water

- (1) Classification. Bilge water which has been exposed to FM-200 fire extinguishing agent in extinguishing a fire, shall be classified and treated as hazardous waste.
- (2) Disposal of Hazardous Waste. Hazardous waste shall be disposed of in accordance with local, state and federal requirements and regulations for hazardous waste.

**2-64. Water Washdown System (WWS).****WARNING**

**The Water Washdown System (WWS) is not designed nor intended to be a stand alone fire extinguishing system. It is designed to be used in conjunction with the installed FM-200 fixed fire extinguishing system.**

**In the event of an onboard fire emergency failure to activate the FM-200 fixed fire extinguishing could result in equipment damage, death or serious injury.**

- a. Authority to Activate WWS. The authority to activate the FM-200 fixed fire extinguishing system and the WWS protecting the engine room, tunnel and bow thruster room will be issued by the person in charge at the scene.

**WARNING**

**To provide adequate flow of seawater to the engine room WWS, the bow thruster emergency fire pump must be operated at minimum pressure of 121 psi.**

**During operation of the WWS, residual capacity of the bow thruster emergency fire pump exists for three 1 ½" fire hoses at full stream or seven 1 ½" hoses at spray. Failure to operate bow thruster ramps at 121 psi could result in equipment damage or serious injury to personnel.**

- b. Activation Procedures Engine Room (WWS). Evacuate all personnel from the protected space. Place Bow Thruster Emergency Fire Pump online at maximum operating pressure.

**WARNING**

**The WWS should always be ready to immediately deploy by disengaging the locking mechanism on the ball valve handle. Pad locking of this handle should only occur during system maintenance or equipment damage, death or serious injury could occur.**

Activate the WWS by unlocking and opening valve WWS-1, Engine Room WWS Control Valve. Valve WWS-1 is located in the Engine Room WWS Control Station located in the Starboard Passageway, main deck, at Frame 40.

**WARNING**

**In the event the FM-200 system electric horn/strobe or warning lights (amber strobe) are activated, leave the protected space immediately.**

**FM-200 is being released within 60 seconds, death or serious injury could occur.**

**NOTE**

**Upon actuation of the FM-200 fire extinguishing system, a 60 second delay in agent discharge will be experienced. During this delay, FM-200 system electric horn/strobe will sound, FM-200 warning bell will sound, and the FM-200 warning lights (amber strobe) will be illuminated.**



Actuate the FM-200 fixed fire extinguishing system in accordance with the instructions referenced in paragraph 2-63.b., and the FM-200 Actuation Placards located at the FM-200 actuation stations.

Actuation of the fixed FM-200 fire extinguishing system will result in automatic shut down of the following equipment and ventilation systems:

Engine Room Supply Fan SF-1 Port	Ships Service Diesel Generator No. Stbd.
Engine Room Exhaust Fan EF-1 Port	Ships Service Diesel Generator No. 2 Port
Engine Room Supply Fan SF-2 Stbd	Main Engine Stbd
Engine Room Exhaust Fan EF-2 Stbd	Main Engine Port
Fuel Oil Transfer Pump No. 1	Fuel Oil Transfer Pump No. 2

**WARNING**

**The Water Washdown System (WWS) is not designed nor intended to be a stand alone fire extinguishing system. It is designed to be used in conjunction with the installed FM-200 Fixed Fire Extinguishing System.**

**In the event of an onboard fire emergency failure to activate the FM-200 Fixed Fire Extinguishing could result in equipment damage, death or serious injury.**

**WARNING**

**To reduce temperatures within the protected space and manage the risk of HF exposure to humans, the WWS is designed and intended to be operated for a minimum of 15 minutes. This procedure should be followed to the full extent or death or serious injury could occur.**

**NOTE**

**Upon automatic shutdown of ships service generators, the emergency diesel generator set will automatically start and place itself on line within 45 seconds.**

Operate the WWS for a minimum of fifteen (15) minutes. During the WWS operating period, approximately every three (3) minutes, open valve WWS-2, engine room WWS strainer blow off for approximately ten (10) seconds. This will allow any foreign matter to be flushed from the in-line strainer basket.

c. Activation Procedures For Tunnel WWS

Evacuate all personnel from the protected space.

**WARNING**

To provide adequate flow of seawater to the tunnel WWS, the two (2) engine room fire pumps must be operated at minimum pressure of 96 psi.

During operation of the WWS, residual capacity of the bow thruster emergency fire pump exists for four 1 ½" fire hoses at full stream or nine 1 ½" hoses at spray. Failure to operate engine room pumps at 96 psi could result in equipment damage or serious injury to personnel.

Place the two (2) engine room fire pumps online at maximum operating pressure.

**WARNING**

The WWS should always be ready to immediately deploy by disengaging the locking mechanism on the ball valve handle. Pad locking of this handle should only occur during system maintenance, equipment damage, death or serious injury could occur.

Activate the WWS by unlocking and opening valve WWS-1, tunnel WWS control valve. Valve WWS-1 is located in the tunnel WWS control station located in the MCC area, below main deck, bulkhead 25, starboard side.

**WARNING**

In the event the FM-200 system electric horn/strobe or warning lights (amber strobe) are activated, leave the protected space immediately.

FM-200 is being released within 60 seconds, death or serious injury could occur.

**NOTE**

Upon actuation of the FM-200 fire extinguishing system, a 60 second delay in agent discharge will be experienced. During this delay, FM-200 system electric horn/strobe will sound, FM-200 warning bell will sound and the FM-200 warning light (amber strobe) will be illuminated.

Actuate the FM-200 fixed fire extinguishing system in accordance with the instructions, reference paragraph 2-63.c., and the FM-200 actuation placards located at the FM-200 actuation stations.

Activation of the fixed FM-200 fire extinguishing system will result in automatic shut down of the following ventilation system:

Tunnel Supply Fan SF-3

### WARNINGS

**The Water Washdown System (WWS) is not designed nor intended to be a stand alone fire extinguishing system. It is designed to be used in conjunction with the installed FM-200 fixed fire extinguishing system.**

**In the event of an onboard fire emergency failure to activate the FM-200 fixed fire extinguishing could result in equipment damage, death or serious injury.**

**To reduce temperatures within the protected space and manage the risk of HF exposure to humans, the WWS is designed and intended to be operated for a minimum of 15 minutes. This procedure should be followed to the full extent or death or serious injury could occur.**

Operate the WWS for a minimum of fifteen (15) minutes. During the WWS operating period, approximately every three (3) minutes, open valve WWS-2, tunnel WWS strainer blow off for approximately ten (10) seconds. This will allow any foreign matter to be flushed from the in-line strainer basket.

d. Activation Procedures Bow Thruster Room WWS

### WARNING

**The Water Washdown System (WWS) is not designed nor intended to be a stand alone fire extinguishing system. It is designed to be used in conjunction with the installed FM-200 fixed fire extinguishing system.**

**In the event of an onboard fire emergency failure to activate the FM-200 fixed fire extinguishing could result in equipment damage, death or serious injury.**

Evacuate all personnel from the protected space.

### WARNING

**To provide adequate flow of seawater to the bow thruster WWS, the two engine room fire pumps must be operated at minimum pressure of 91 psi.**

**During operation of the WWS, residual capacity of one engine room fire pump exists for two 1 ½" fire hoses at full stream or four 1 ½" hoses at spray.**

**During operation of the WWS, residual capacity of the two engine room fire pumps exists for four 1 ½" fire hoses at full stream or nine 1 ½" hoses at spray. Failure to operate the two engine room pumps at 91 psi could result in equipment damage or serious injury to personnel.**

Place the two (2) engine room fire pumps online at maximum operating pressure.

Activate the WWS by unlocking and opening valve WWS-1, bow thruster room WWS control valve. Valve WWS-1 is located in the bow thruster room WWS control station located in the tunnel, below main deck, bulkhead 17, starboard side.

**WARNING**

**The WWS should always be ready to immediately deploy by disengaging the locking mechanism on the ball valve handle. Pad locking of this handle should only occur during system maintenance or equipment damage, death or serious injury could occur.**

Actuate the FM-200 fixed fire extinguishing system in accordance with the instructions contained in paragraph 2-63.d., and the FM-200 actuation placards located at the FM-200 actuation stations.

**WARNING**

**In the event the FM-200 system electric horn/strobe or warning lights (amber strobe) are activated leave the protected space immediately.**

**FM-200 is being released within 60 seconds, death or serious injury could occur.**

**NOTE**

**Upon actuation of the FM-200 fire extinguishing system, a 60 second delay in agent discharge will be experienced. During this delay, FM-200 system electric horn/strobe will sound, FM-200 warning bell will sound, and the FM-200 warning light (amber strobe) will be illuminated.**

Activation of the fixed FM-200 fire extinguishing system will result in automatic shut down of the following equipment and ventilation system:

Bow Thruster Room Supply Fan

Bow Thruster Room Diesel Engine

**WARNING**

**The Water Washdown System (WWS) is not designed nor intended to be a stand alone fire extinguishing system. It is designed to be used in conjunction with the installed FM-200 fixed fire extinguishing system.**

**In the event of an onboard fire emergency failure to activate the FM-200 fixed fire extinguishing could result in equipment damage, death or serious injury.**

Operate the WWS for a minimum of fifteen (15) minutes. During the WWS operating period, approximately every three (3) minutes, open valve WWS-2, bow thruster room WWS strainer blow off for approximately ten (10) seconds. This will allow any foreign matter to be flushed from the in-line strainer basket.

**WARNING**

**To reduce temperatures within the protected space and manage the risk of HF exposure to humans, the WWS is designed and intended to be operated for a minimum of 15 minutes. Failure to follow this procedure to the full extent could result in serious injury or death to personnel.**

- e. Post Fire Re-Entry.

Authorization to Re-Enter Protected Space. Authorization to re-enter the protected space, after discharge of the FM-200 fixed fire extinguishing system and WWS, shall be issued by the person in charge at the scene.

**WARNING**

**Dependent upon the temperature of the fire within the protected space prior to the 15 minute period of water washdown, the protected space may contain a level of HF gas which is dangerous to humans. Testing to verify the level of HF gas is safe for re-entry must be performed and followed to the full extent of the re-entry testing procedures. Failure to follow these procedures could result in death or serious injury to personnel.**

- f. Testing For Re-Entry. Prior to re-entry into the protected space shall be tested for levels of HF gas. These procedures are referenced in paragraph 2-63.i.
- g. Re-Entry Procedures. After testing verifies the protected space is safe for re-entry and the person in charge at the scene issues authorization to re-enter the protected space, the re-entry procedures detailed in paragraph 2-63.j., must be followed to the full extent.
- h. Bilge Water Classification. Bilge water which has been exposed to FM-200 fire extinguishing agent in extinguishing a fire, shall be classified and treated as hazardous waste.
- i. Disposal of Contaminated Bilge Water. Contaminated bilge water shall be disposed of in accordance with local, state and federal requirements and regulations for hazardous waste.

**CHAPTER 3**

**MAINTENANCE INSTRUCTIONS**

**3-1. General** Maintenance instructions and troubleshooting information are found in TM 55-1905-223-24-Series. Refer to Appendix A, References. For lubrication instructions, refer to LO 55-1905-223-12.

**3-1/(3-2 blank)**

**APPENDIX A**

**REFERENCES**

**A-1. Scope.** This appendix lists all forms, field manuals, technical manuals and miscellaneous publications referenced in this manual.

**A-2. Forms**

Deck Department Log ..... DA Form 4640

Engine Department Log ..... DA Form 4993

Equipment Inspection and Maintenance Work Sheet..... DA Form 2404

Quality Deficiency Report..... SF 368

Recommended Changes to Publications and Blank Forms ..... DA Form 2028

**A-3. Field Manuals**

NBC Decontamination..... FM 3-5

First Aid For Soldiers..... FM 21-11

**A-4. Technical Manuals**

Lubrication Order For Landing Craft, Utility (LCU)..... LO 55-1905-223-12

Unit, Intermediate Direct Support and Intermediate General Support  
Maintenance Instructions Including Repair Parts and Special Tools  
List for the Landing Craft, Utility Vessel..... TM 55-1905-223-24&P

Unit, Intermediate Direct Support and Intermediate General Support  
Maintenance Instructions for Main Propulsion Engine..... TM 55-1905-223-24-1

Unit, Intermediate Direct Support and Intermediate General Support  
Maintenance Instructions for Main Reduction Gear..... TM 55-1905-223-24-2

Unit, Intermediate Direct Support and Intermediate General Support  
Maintenance Instructions for Ship's Service Generator Set ..... TM 55-1905-223-24-3

Unit, Intermediate Direct Support and Intermediate General Support  
Maintenance Instructions for Emergency Generator ..... TM 55-1905-223-24-4

Unit, Intermediate Direct Support and Intermediate General Support  
Maintenance Instructions for Bowthruuster Engine ..... TM 55-1905-223-24-5

**TM 55-1905-223-10**

Unit, Intermediate Direct Support and Intermediate General Support  
Maintenance Instructions for Bowthruster Waterjet ..... TM 55-1905-223-24-6

Unit, Intermediate Direct Support and Intermediate General Support  
Maintenance Instructions for Reverse Osmosis Watermaker..... TM 55-1905-223-24-7

Unit, Intermediate Direct Support and Intermediate General Support  
Maintenance Instructions for Air Compressor..... TM 55-1905-223-24-8

Unit, Intermediate Direct Support and Intermediate General Support  
Maintenance Instructions for Steering Gear ..... TM 55-1905-223-24-9

Unit, Intermediate Direct Support and Intermediate General Support  
Maintenance Instructions for Bow Ramp Assembly ..... TM 55-1905-223-24-10

Unit, Intermediate Direct Support and Intermediate General Support  
Maintenance Instructions for Marine Sanitation System..... TM 55-1905-223-24-11

Unit, Intermediate Direct Support and Intermediate General Support  
Maintenance Instructions for Fire Pumps Subsystem ..... TM 55-1905-223-24-12

Unit, Intermediate Direct Support and Intermediate General Support  
Maintenance Instructions for Bilge/Ballast Pump ..... TM 55-1905-223-24-13

Unit, Intermediate Direct Support and Intermediate General Support  
Maintenance Instructions for Gyro and  
Magnetic Compass Systems ..... TM 55-1905-223-24-14

Unit, Intermediate Direct Support and Intermediate General Support  
Maintenance Instructions for Bow Anchor Windlass Subsystem..... TM 55-1905-223-24-15

Unit, Intermediate Direct Support and Intermediate General Support  
Maintenance Instructions for Stern Anchor Winch..... TM 55-1905-223-24-16

Unit, Intermediate Direct Support and Intermediate General Support  
Maintenance Instructions for Environmental Control Subsystem ..... TM 55-1905-223-24-17

Unit, Intermediate Direct Support and Intermediate General Support  
Maintenance Instructions for Landing Craft Utility  
(LCU) Basic Craft ..... TM 55-1905-223-24-18

Unit, Intermediate Direct Support and Intermediate General Support  
Maintenance Instructions Including Repair Parts and Special  
Tools List for the FM-200 Fire Fighting System..... TM 55-1905-243-24&P



Organizational Operation and Maintenance  
Instructions for the Satellite  
Signals Navigation Set.....NAVY SPAWAR EE170-AA-OMI-010/WRN-6  
ARMY TM 11-5826-311-12-2-1

Organizational Operation and Maintenance  
Instructions for the Satellite  
Signals Navigation Set.....NAVY SPAWAR EE170-AA-OMI-020/WRN-6  
ARMY TM 11-5826-311-12-2-2

**A-5. Technical Bulletins.**

Warranty Procedures for Landing Craft,  
Utility (LCU).....TB 55-1905-223-24

**A-6. Miscellaneous Publications.**

The Army Maintenance Management  
System (TAMMS).....DA Pam 738-750

Army Medical Department Expendable Items.....CTA 8-100

Consolidated Index of Army Publications and  
Blank Forms.....DA Pam 25-30

Expendable/Durable Items.....CTA 50-970

Navigation Rule, International-Inland.....COMDINST 16672.2A

Soldier's Manual of Common Tasks  
(Skill Level 1).....STP 21-1



**APPENDIX B  
COMPONENTS OF END ITEM (COEI) AND  
BASIC ISSUE ITEMS (BII) LISTS**

---

**SECTION I. INTRODUCTION**

**B-1. SCOPE** This appendix lists components of the end item and basic issue items for the Landing Craft, Utility (LCU-2000) to help you inventory the items for safe and efficient operation of the equipment.

**B-2. GENERAL** The Components of End Item (COEI) and Basic Issue Items (BII) Lists are divided into the following sections:

a. Section II, Components of End Item. This Technical Manual is your authority to requisition replacements. These items are part of the LCU-2000, but they may be removed and separately packaged for transportation or shipment. As part of the end item, these items must be with the end item whenever it is issued or transferred between property accounts.

b. Section III, Basic Issue Items. These essential items are required to place the LCU-2000 in operation, operate it, and to do emergency repairs. Although shipped separately packaged, BII must be with the LCU-2000 during operation and when it is transferred between property accounts. This Technical Manual is your authority to request/requisition replacement BII based on authorization of the end item by the TOE/MTOE.

**B-3. EXPLANATION OF COLUMNS.**

a. Column (1), Illustration Number, gives you the number of the item illustrated. (Not used,)

b. Column (2), National Stock Number, identifies the stock number of the item to be used for requisitioning purposes.

c. Column (3), Description and Useable On Code, identifies the Federal item name followed by a minimum description when needed. The last line below the description is the CAGEC (Commercial And Government Entity Code) (in parenthesis) and the part number. If the item you need is not the same for different models of the equipment, a Usable On Code will appear on the right side of the description column on the same line as the part number. (There are no Usable On Codes for the LCU-2000 at this time.)

d. Column (4), U/M (unit of measure), indicates how the item is issued for the National Stock Number (NSN) shown in column (2).

e. Column (5), Qty rqr, indicates the quantity required.

## SECTION II. COMPONENTS OF ITEM LIST

(1) ILLUS NO.	(2) NATIONAL STOCK NUMBER	(3) DESCRIPTION FSCM AND PART NUMBER	(4) USABLE ON CODE	(5) QTY REQ'D
1A	5825-01-227-4812	Antenna AS-3819/SRN	EA	1
1B	5826-01-228-9402	Antenna Amplifier AM 7314/URN	EA	1
		Antenna, OMNI Directional (02339) MR-106-36D	EA	1
		Amplifier, Television (3L921) Model 4320	EA	1
		Berth, Shipboard (00096) 471-3 C	EA	2
		Berth, Shipboard (00096) 471-6A C	EA	1
		Berth, Shipboard (00096) 471-6 C	EA	5
		Berth, Hospital (00096) 552-2 C	EA	1
	7195-00-224-5190	Board, Bulletin, Type A, 28" X 42" (81349) MIL-F-902	EA	2
	7195-00-224-5191	Board, Bulletin, Type B, 23" x 33" (81349) MIL-F-902	EA	2
		Board, Rudder Course (00096) 148-11 C	EA	1
		Board, Status (00096) 148-12 C	EA	1
		Bookcase (00096) 684-1 C	EA	1
		Bookrack, Double (00096) 630-5A C	EA	5
		Bookrack, Single (00096) 30-5C	EA	1

SECTION II. COMPONENTS OF ITEM LIST

(1) ILLUS NO.	(2) NATIONAL STOCK NUMBER	(3) DESCRIPTION FSCM AND PART NUMBER	(4) USABLE ON CODE U/M	(5) QTY REQ'D
		Bulletin Board (00096) 148-5N	EA	2
		Cabinet, Coffee (00096) 14-1-1 C	EA	1
		Cabinet, File (00096) 126C	EA	1
	2090-00-782-3038	Cabinet, Filing, Four Drawer w/ Combination Lock (80064) 805-1638842	EA	1
	7125-00-132-8973	Cabinet, Key 75 Key, Steel, Gray, Type 2, Class A (81348) AA-C-30	EA	2
		Chest of Drawers (00096) 14-C C	EA	6
		Coffee Maker, Perculator (93335) Model 43536	EA	1
		Compactor, Solid Waste (81306) Model TU8000XR	EA	1
		Console, Entertainment (00096)12-8 CG	EA	1
		Desk, Flat Top (00096) 164-4 C	EA	2
		Dishwasher (17581) Model UC-1	EA	1
		Desk, Log (00096)	EA	1
		Dispenser, Beverage (51267) Model 417405000	EA	1

SECTION II. COMPONENTS OF ITEM LIST

(1) ILLUS NO.	(2) NATIONAL STOCK NUMBER	(3) DESCRIPTION FSCM AND PART NUMBER	(4) USABLE ON CODE U/M	(5) QTY REQ'D
		Dispenser, Milk (28535) MD2-SSC-1	EA	1
		Disposal, Garbage (52827) Model BB-325/750C	EA	1
		Dryer, Automatic 59618) Model SE-4732	EA	1
1C	5825-01-230-2252	Electrical Equipment Mounting Base MT-6486/SRN	EA	1
1F	5825-01-251-1250	Electrical Equipment Mounting Base MT 6586/S	EA	1
		Flag Bag, Portable, Aluminum 20 Gauge, 27-1/2" x 13 x 26, Hinged, 72 Compart- ments, 3" x 3-1/2" x 13", w/Lock and Handles (00096) 454-9C	EA	1
		Freezer, Double (66682) Model F30-2M-ADS	EA	1
		Freezer, Mechanical (66682) Model F20-2M-ADS	EA	1
		Fryer, Deep (78770) Model 1435	EA	1
		Gyro, Compass (03956)	EA	1
1D	5826-01-230-9368	Indicator Control C-11702/UR	EA	1
		Insert, Writing (00096) 14-2 C	EA	6
		Lashing Gear, Vehicle, 17,000 lb Breaking Strength (80064) 805-1313817	AY	50

## SECTION II. COMPONENTS OF ITEM LIST

(1) ILLUS NO.	(2) NATIONAL STOCK NUMBER	(3) DESCRIPTION FSCM AND PART NUMBER	(4) USABLE ON CODE U/M	(5) QTY REQ'D
		Lashing Gear, Vehicle, 35,000 lb Breaking Strength (80064) 805-1313817	AY	60
		Leaf Unit, Hinged (00096)527-14-3-1 N	EA	1
	6230-00-789-1065	Light, Desk, Chart Table (w/Filter Assy MIL-STD-16721) (81349) M16377/15-148.2	EA	1
		Locker (00096) E1792	EA	1
		Locker (00096) 207-3-2 C	EA	1
		Locker (00096) 207-3-3C	EA	1
		Locker, Ammunition (00096) 4210	EA	2
		Locker Ammunition (00096) 766	EA	1
		Locker, Bulkhead Mou (00096) 207-1-2 C	EA	1
		Locker, Damage Control (00096) 351-14N	EA	1
	2090-00-956-3017	Locker, Fuse, Aluminum 15" x 11-3/8" (80064) 805-1363771	EA	1
	2090-00-956-3016	Locker, Fuse, Aluminum 26-1/8" x 15/16" (80064) 805-1363770	EA	1
		Locker, Machine Gun (00096) 7621	EA	1

## SECTION II. COMPONENTS OF ITEM LIST

(1) ILLUS NO.	(2) NATIONAL STOCK NUMBER	(3) DESCRIPTION FSCM AND PART NUMBER	(4) USABLE ON CODE	(5) QTY REQ'D
		Locker, Medicine (00096) 444-12 C	EA	1
	2040-00-823-2478	Locker, Pyrotechnic (80064) 805-1360275REVBR	EA	1
		Locker, Small Arms (00096) 7618	EA	1
		Locker, Wardrobe (00096) SK 9-N	EA	1
		Machine, Welding, Electric (06073) 1341-0354	EA	1
		Meat, Slicing Machine (60438) Model 512	EA	1
		Mirror, Full Length (00096) 6-10P C	EA	2
		Mixing Machine, Food Electric (7L611) Model B20T	EA	1
		Motor, Outboard (63931) 7040211N	EA	1
		Oven, Microwave (14852) Model RC-20SE	EA	1
		Pad, Deck (00096) 802-5	EA	32
		Rack, Life Preservers (00096) 351-11 C	EA	6
1E	5825-01-318-9429	Radio Receiver R-2331/URN	EA	1
		Range, Electrical (78770) MR36D1	EA	1



## SECTION II. COMPONENTS OF ITEM LIST

(1) ILLUS NO.	(2) NATIONAL STOCK NUMBER	(3) DESCRIPTION FSCM AND PART NUMBER	(4) USABLE ON CODE U/M	(5) QTY REQ'D
		Recorder, Video Cassette (5F940) 53293	EA	1
		Refrigerator (00096) 870-20 C	EA	3
		Refrigerator, Double (66682) Model R30-2M-S	EA	1
		Refrigerator, Mechanical (66682) Model R20-2M-S	EA	1
		Safe (00096) 153-19 C	EA	1
		Safe (00096) 331 N	EA	3
		Scale, Bakers (17087) Model 1002TB	EA	1
		Server (00096) 12-1 C	EA	1
		Sideboard (00096) 12-16 C	EA	1
		Table, Chart (00096) 178-55-1 C	EA	1
		Table, Mess (00096) 66-5 C	EA	2
		Table, Night (00096) 14-5 C	EA	2
		Table, Night (00096) 14-5 C MOD	EA	1
		Television, Color (54590) FMR490D	EA	1

SECTION II. COMPONENTS OF ITEM LIST

(1) ILLUS NO.	(2) NATIONAL STOCK NUMBER	(3) DESCRIPTION FSCM AND PART NUMBER	(4) USABLE ON CODE	(5) U/M QTY REQ'D
		Wardrobe (00096) 25-4 C		EA 11
		Washer, Automatic (59618) Model WA-4721		EA 1
		Work Boat, Inflatable (6A840) 4 Meter Searider		EA 1
		Workbench (00096) 210-24 C		EA 1
		Wringer, Clothes (50962) 76-3		EA 1

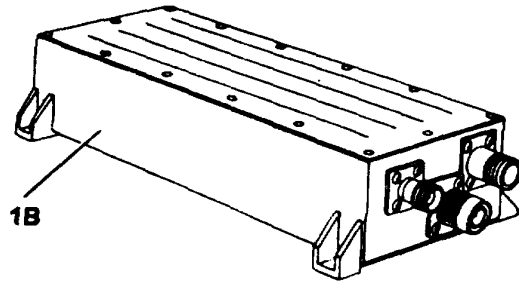
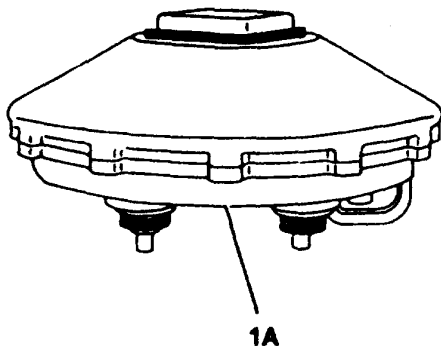

**NOTE**  
 Item 1B is shown for information only. Item 1B is permanently installed in item 1A and should not be removed. Item 1A should not be opened for any reason.

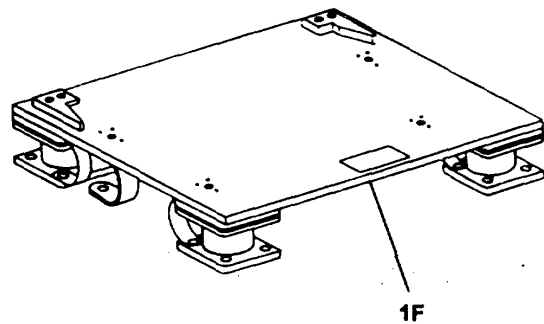
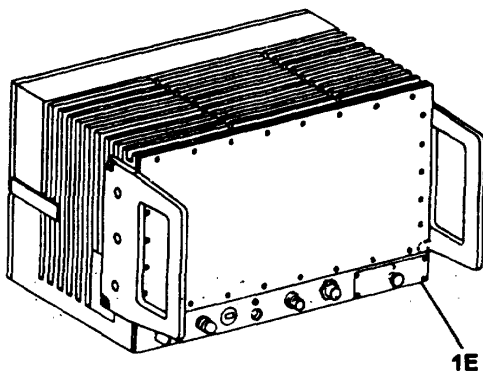
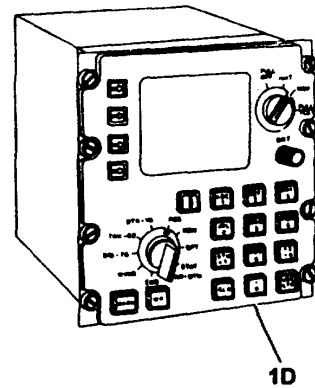
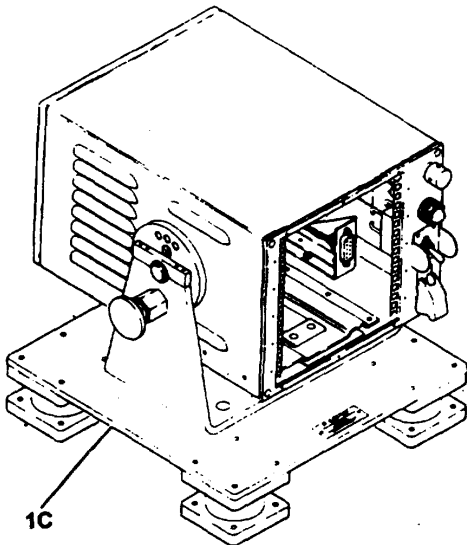

Figure B-1. Satellite Signals Navigation Set AN/WRN-6(V)

APPENDIX B

Section II. COMPONENTS OF END ITEMS  
ON-BOARD SPARES

(1) Illus Number	(2) National Stock Number	(3) Description FSCM and Part Number	(4) Usable On Code U/I	(5) Qty Req
		<p align="center"><b>NOTE</b></p> <p><b>This listing represented authorized levels of repair parts required to be on the LCU-2000 at all times. Use this technical manual as your authority to requisition replacement items.</b></p>		
		<p align="center"><u>FUNCTION GROUP 01</u> <u>MAIN ENGINES</u></p>		
	5305-01-286-8860	Screw, Cap, Hexagon Head (15434) 108602	EA	6
	5340-00-400-3449	Clamp, Loop (15434) 108722 Lever, Throttle (15434) 11048108	EA	1
	4730-01-211-1814	Elbow, Male Adapter (15434) 112105	EA	1
	5930-01-122-1252	Oil Pressure Safety Control (15434) 194504	EA	1
	5930-01-117-7736	Water Temperature Safety Control (15434) 194505	EA	1
	5310-01-201-8622	Washer, Flat (15434) 205059	EA	6
	5315-01-210-1409	Ring, Dowel (15434) 205129	EA	6
	5365-01-201-8708	Ring, Retaining (15434) 205439	EA	4
	3040-01-200-3010	Link, Injector Plunger (15434) 205462	EA	2
	2815-01-044-1455	Rod Push, Engine Poppet (15434) 205492	EA	2

APPENDIX B

Section II. COMPONENTS OF END ITEMS  
ON-BOARD SPARES-Continued

(1) Illus Number	(2) National Stock Number	(3) Description FSCM and Part Number	(4) Usable On Code U/I	(5) Qty Req
	5330-01-043-5604	Gasket, Turbocharger (15434) 206576	EA	2
	4330-01-287-9740	Filter Element, Fluid (15434) 256835	EA	8
	3120-01-043-4254	Thrust Bearing (15434) 3000139	EA	1
	5315-01-266-7583	Pin, Straight, Headless (15434) 3001719	EA	1
	2910-01-234-8234	Clamp, Injector (15434) 3006696	EA	2
	2815-01-207-3716	Cylinder Liner Kit (15434) 3007525	EA	2
	5930-01-262-5090	Switch, Pressure (15434) 3010647	EA	1
	5930-01-262-5089	Switch, Pressure (15434) 3010649	EA	1
	5930-01-273-7627	Speed Switch (15434) 3011573	EA	1
	5305-01-186-7394	Bolt, Assembled Washer (15434) 3012474	EA	6
	2910-01-079-3320	Diaphragm (15434) 3013811	EA	2
	5365-01-207-0727	Bushing, Rubber (15434) 3014304	EA	12
	2815-01-199-6608	Rod, Push, Engine Poppet (15434) 3017961	EA	2
	2940-01-287-9745	Element, Air Cleaner, Intake (15434) 3018042	EA	8
	4720-01-286-8861	Hose Assembly, Nonmetallic (15434) 3019035	EA	2

APPENDIX B

Section II. COMPONENTS OF END ITEMS  
ON-BOARD SPARES-Continued

(1) Illus Number	(2) National Stock Number	(3) Description FSCM and Part Number	(4) Usable On Code U/I	(5) Qty Req
	2815-01-199-6703	Cylinder Head; Diesel Engine (15434) 3021692	EA	3
	6620-01-169-9307	Thermostat (15434) 3022299	EA	4
	5330-01-201-3645	Gasket, Cylinder Head(15434) 3022340	EA	3
	2990-01-262-2340	Relay, Air Valve (15434) 3022697	EA	1
	2815-01-391-3290	Oil Control (15434) 3025451	EA	2
	2815-01-391-3291	Piston Ring, Compression 15434) 3026595	EA	2
	4820-01-262-2376	Valve, Safety Relief (15434)	EA	1
	4730-01-201-0727	Coupling Tube (15434) 3031404	EA	1
	4730-01-288-9887	Pump, Rotary (15434) 3032869	EA	1
	2815-01-262-3436	Pump, Oil (15434) 3038725	EA	1
	5340-01-238-7107	Connecting Rod Assembly (15434) 3043910	EA	2
	3120-01-303-9639	Bearing, Connecting Rod (15434) 3047390	EA	2
	2910-01-262-5183	Piston Cooling Nozzle (15434) 3044464	EA	1
	3010-00-507-8347	Insert, Flexible Coupling (15434) 3046200	EA	1
	2815-01-250-8088	Lever, Exhaust Rocker (15434) 3047599	EA	1
	2815-01-262-5072	Valve, Crosshead (15434) 3048620	EA	4

APPENDIX B

Section II. COMPONENTS OF END ITEMS  
ON-BOARD SPARES-Continued

(1) Illus Number	(2) National Stock Number	(3) Description FSCM and Part Number	(4) Usable On Code U/I	(5) Qty Req
	2930-01-286-6259	Pump, Cooling System, Engine (15434) 3050447	EA	1
	2910-01-262-5178	Injector Assembly, Fuel (15434) 3053124	EA	16
	5365-01-199-6615	Ring, Injector Sealing (15434) 207244	EA	16
	2815-01-391-0861	Rocker Arm, Engine Poppet Valve (15434) 3053476	EA	1
	2815-01-391-1503	Lever, Injector Rocker (15434) 3053478	EA	1
	4710-01-262-7323	Fuel Supply Lines (15434) 3175738	EA	1
	4710-01-262-7324	Fuel Drain Lines (15434) 3175739	EA	1
	4710-01-262-7325	Fuel Supply Lines (15434) 3175740	EA	2
	4710-01-262-2419	Fuel Drain Lines (15435) 3175714	EA	1
	4710-01-199-4361	Fuel Drain Lines (15434) 3175745	EA	1
		Conn and Ferrule Assembly (15434) 317614	EA	1
	4720-01-287-9731	Hose Assembly, Metalic (15434) 3177338	EA	1
	4710-01-262-2418	Pipe, Bent, Metallic (15434) 3177708	EA	2
	5330-01-043-5601	Gasket, Rocker Leverhousing (15434) 3201517	EA	2
	2910-01-262-2402	Pump, Fuel, Cam Actuated (15434) 3279711-B644	EA	1
	4330-01-262-5170	Filter Element, Fluid (15434) 3313282	EA	10

APPENDIX B

Section II. COMPONENTS OF END ITEMS  
ON-BOARD SPARES-Continued

(1) Illus Number	(2) National Stock Number	(3) Description FSCM and Part Numbe	(4) Usable On Code U/I	(5) Qty Req
	2940-01-241-4758	Filter Element, Fluid (15434) 3313283	EA	8
	5905-01-245-9790	Element, Water Filter (15434) 3318318	EA	8
	2815-01-262-2389	Piston Assembly (15434) 3801436	EA	2
	5330-01-262-5149	Gasket Set (Single Head) (15434) 3801643	EA	3
	5330-01-262-5147	Gasket Set Engine (Lower) (15434) 3801717	EA	1
	5330-01-262-5148	Gasket, Set Engine (Upper) (15434) 3801718	EA	1
	2950-01-288-5543	Turbocharger (15434) 3801846	EA	1
	2995-01-253-6394	Starter Rebuild Kit (57301) 52-029	EA	1
	2990-01-262-7326	Starter, Main Engine (57301) 52447-12	EA	1
	2815-01-042-9986	Ring Set, Piston (15434) AR-10680	EA	2
	2910-00-828-7126	Damper (15434) BM-76340	EA	1
	3110-00-554-3197	Bearing, Ball,, Annular (15434) S-16054	EA	2
	3110-00-293-9302	Bearing, Ball, Annular (15434) S-16069	EA	2
	5330-01-312-3868	<u>FUNCTIONAL GROUP 02</u> <u>-REDUCTION GEARS</u> Kit, Performed Packing (68225) 3A40404	EA	1



APPENDIX B

Section II. COMPONENTS OF END ITEMS  
ON-BOARD SPARES-Continued

(1) Illus Number	(2) National Stock Number	(3) Description FSCM and Part Number	(4) Usable On Code U/I	(5) Qty Req
	5330-01-287-1309	Gasket Set (68225) 45C109	EA	1
	4330-01-287-9741	Filter Element, Fluid (D8835) 37A126	EA	3
		Bearing, Anti-Friction (68225) WAV850-E18	EA	2
		Pump, Oil (68225) WAV850-E19	EA	1
		<u>FUNCTION GROUP 03-</u> <u>S.S. GENERATOR SET</u>		
	5905-01-262-2343	Resister, Droop (4X687) 071-09658	EA	1
	4720-01-287-1309	Hose (15434) 102522	EA	1
	5930-00-956-2484	Switch Toggle (15434) 104215	EA	1
	2910-00-298-3505	Connection Fuel (15434) 147100	EA	2
	4720-01-085-6131	Hose, Plain (15434) 155789	EA	2
	5340-00-933-3009	Seat, Helical Compression Spring (15434) 170296	EA	2
	5330-00-864-5422	Seal, Thermostat (15434) 186780	EA	1
	2950-00-432-1562	Adapter, Exhaust Manifold (15434) 186918	EA	1
	6620-01-141-0907	Thermostat, Flow Control (15434) 201737	EA	1
	3120-01-087-3004	Bearing (15434) 214950	EA	12

APPENDIX B

Section II. COMPONENTS OF END ITEMS  
ON-BOARD SPARES-Continued

(1) Illus Number	(2) National Stock Number	(3) Description FSCM and Part Number	(4) Usable On Code U/I	(5) Qty Req
	3030-01-065-9404	Belt, V (15434) 217638	EA	2
	5305-01-129-6901	Screw, Assembled Washer (15434) 3010589	EA	2
	5305-01-112-9021	Screw, Assembled Washer (15434) 3013904	EA	1
	2815-01-086-4508	Connecting Rod Assembly (15434) 3013930	EA	2
	5905-01-264-2114	Potentiometer (15434) 3015105	EA	1
	6620-01-239-3804	Gage, Oil Pressure (15434) 3015232	EA	1
	6620-00-365-5572	Gage, Water Temperature (15434) 3015234	EA	1
	6625-01-240-5073	Voltmeter (15434) 3015235	EA	1
	6625-01-240-5147	Transducer (15434) 3015238	EA	1
	6625-01-240-5146	Transducer (15434) 3015237	EA	1
	2920-01-244-6058	Starter, Engine, Electrical (15434) 3021036	EA	1
	2930-01-065-7113	Core Radiator (15434) 3021581	EA	4
	2940-01-266-7691	Filter Element, Intake Air Cleaner (15434) 3022209	EA	2
	2910-01-150-4925	Clamp, Injector (15434) 3031137	EA	2
	6680-01-239-5702	Tachometer (15434) 3031734	EA	1

APPENDIX B

Section II. COMPONENTS OF END ITEMS  
ON-BOARD SPARES-Continued

(1) Illus Number	(2) National Stock Number	(3) Description FSCM and Part Number	(4) Usable On Code U/I	(5) Qty Req
	4810-01-278-7350	Fuel Shut Down (15434) 3018453	EA	1
	2815-01-085-8282	Cylinder Head, Diesel Engine (15434) 3041993	EA	1
	2815-01-263-0137	Rod, Push (15434) 3046420	EA	4
	2815-01-262-2346	Rod, Push (15434) 3046430	EA	2
	5930-01-287-9744	Switch, Magnetic (15434) 3050692	EA	1
	2910-01-262-5181	Nozzle, Fuel Injection (15434) 3054219	EA	6
	5945-01-304-2178	Solenoid (15434) 3054609	EA	1
	2940-01-019-4513	Filter Element, Fluid (15434) 3313279	EA	3
	4330-01-262-5172	Filter Element, Fluid (15434) 3313289	EA	3
	2910-01-245-9782	Cartridge, Fuel (15434) 3315847	EA	12
	4330-01-262-5169	Filter, Fluid (15434) 3318319	EA	2
	2815-01-165-0756	Piston Rings Kit (15434) 3801056	EA	6
	3120-01-132-9339	Bearing Set, Sleeve (15434) 3801260	EA	1
	5330-01-149-9715	Gasket Set Engine (Complete) (15434) 3801330	EA	2
	2930-01-146-3912	Pump, Cooling System, Engine (15434) 3801708	EA	1

APPENDIX B

Section II. COMPONENTS OF END ITEMS  
ON-BOARD SPARES-Continued

(1) Illus Number	(2) National Stock Number	(3) Description FSCM and Part Number	(4) Usable On Code U/I	(5) Qty Req
	2815-00-011-7786	Cylinder Liner Kit (15434) 3801826	EA	6
	2815-01-262-9492	Piston Assembly (15434) 3801876	EA	6
	2950-01-262-5174	Turbosupercharger, Non-Aircraft (15434) 3801941	EA	1
	2990-01-262-9501	Starter, Engine, Air (57301) 42KG312-08-601	EA	1
		Resistor, Variable (4X687) 450-11760	EA	1
	5350-01-262-2342	Transformer, Droop (4X687) 450-23300	EA	1
		Pump. Oil (15434) AR9824	EA	1
		<u>FUNCTION GROUP 04-AUX, GENERATOR SET</u>		
	2940-01-313-0869	Filter Element, Intake Air Cleaner (44940) 140-2159	EA	1
	6110-01-262-2353	Regulator, Voltage (44940) 305-0770	EA	1
	2930-01-237-6299	Engine Water Pump (15434) 3802004	EA	1
	2815-01-194-3722	Valve, Poppet, Engine, Intake (15434) 3802005	EA	4
	2815-01-194-3723	Valve, Poppet, Engine, Exhaust (15434) 3802006	EA	4
	3120-01-211-5250	Bearing, Set (15434) 3802010	EA	1
	5330-01-266-7643	Kit, Upper Engine, Gasket (15434) 3802016	EA	1

## APPENDIX B

Section II. COMPONENTS OF END ITEMS  
ON-BOARD SPARES-Continued

(1) Illus Number	(2) National Stock Number	(3) Description FSCM and Part Number	(4) Usable On Code U/I	(5) Qty Req
	5330-01-263-5735	Kit, Lower Engine, Gasket (15434) 3802019	EA	1
	2815-01-278-0876	Set, Engine, Piston (15434) 3802100	EA	4
	2950-01-313-5968	Turbosupercharger, Non-Aircraft (15434) 3802113	EA	1
	5360-00-804-2769	Ring, Retaining (15434) 3901706	EA	8
	2815-01-211-3886	Pin, Piston (15434) 3901793	EA	2
	2815-01-211-5270	Valve, Pressure Relief (15434) 3902338	EA	1
	4330-01-233-8768	Filter, Fluid (15434) 3903202	EA	4
	5330-01-190-1940	Gasket, Thermostat Housing Cover (15434) 3903301	EA	1
	2919-01-216-4192	Pump, Fuel, Cam Actuated (15434) 3904374	EA	1
	4730-01-234-6308	Connector, Multiple, Fluid Pressure Line (15434) 3904645	EA	1
	5306-01-234-3716	Bolt, Fluid Passage (15434) 3904646	EA	1
	2910-01-233-8922	Filter Element, Fluid (15434) 3904652	EA	4
	2815-01-194-3884	Push Rod, Engine Poppet Valve (15434) 3904679	EA	2
	2015-01-313-2843	Kit Cylinder Block (15434) 3904991	EA	1
	2815-01-237-3552	Oil Pump, Assembly, Engine (15434) 3906413	EA	1

## APPENDIX B

Section II. COMPONENTS OF END ITEMS  
ON-BOARD SPARES-Continued

(1) Illus Number	(2) National Stock Number	(3) Description FSCM and Part Number	(4) Usable On Code U/I	(5) Qty Req
		Spring, Helical, Compression (15434) 3907493	EA	1
		Filter Element, Fluid (15434) 3908616	EA	1
		Seal, Oil (15434) 3909410	EA	2
		Starter, Engine, Electrical (15434) 3909914	EA	1
		Cylinder Head, Diesel (15434) 3910275	EA	1
		Lever, Rocker (15434) 3910810	EA	2
		Lever, Rocker (15434) 3910811	EA	2
		Support, Rocker Lever (15434) 3910814	EA	1
		Injector (15434) 3911185	EA	4
		Alternator (15434) 3911462	EA	1
		Belt, V (15434) 3911560	EA	1
		Pump, Fuel Metering and Distributing (15434) 3912852	EA	1
		Tube, Flexible (15434) 3913759	EA	1
		Retainer, Packing (15434) 3913994	EA	1

**APPENDIX B  
SECTION II. COMPONENTS OF END ITEMS ON-BOARD SPARES - CONT**

(1) ILLUS NO.	(2) NATIONAL STOCK NUMBER	(3) DESCRIPTION FSCM AND PART NUMBER	(4) USABLE ON CODE U/M	(5) QTY REQ'D
		<b><u>FUNCTION GROUP 05 - B/THRUSTER ENGINE</u></b>		
		Lever, Governor Control (15434) 110481	EA	1
		Switch Toggle (15434) 113527	EA	1
		Clamp, U Bolt (15434) 125245	EA	1
		Connection Exhaust Flexible (15434) 156816	EA	1
		Sea Water Pump V Belt (15434) 178691	EA	2
		Belt, V (15434) 217638	EA	1
		Kit, Sea Water Pump Minor (15434) 3015478	EA	1
		Repair Kit Water Pump (15434) 3050447	EA	1
		Nozzle, Fuel Injection (15434) 3054218	EA	6
		Pump, Fuel, Metering and Distributing (15434) 3057817-9348	EA	1
		Gasket Set, Engine (15434) 3801463	EA	1
		Turbosupercharger, Non-Aircraft (15434) 3801614	EA	1
		Piston Assembly (15434) 3810770	EA	2
		Kit, Cylinder (15434) 3801779	EA	2

**APPENDIX B**  
**SECTION II. COMPONENTS OF END ITEMS ON-BOARD SPARES - CONT**

(1) ILLUS NO.	(2) NATIONAL STOCK NUMBER	(3) DESCRIPTION FSCM AND PART NUMBER	(4) USABLE ON CODE U/M	(5) QTY REQ'D
		Plug Zinc Electrode (15434) 68241	EA	2
		Pump Oil (15434) AR-10172	EA	1
		Bearing, Pilot (61208) M-224	EA	1
		<b><u>FUNCTION GROUP 06 - B/THRUSTER WATER JET</u></b>		
		Cross, Bearing Assembly (32862) 287.00.06.01.010	EA	2
		Cartridge, Filter (32862) H68/1	EA	4
		<b><u>FUNCTION GROUP 07 - R/O WATER MAKER</u></b>		
		Sodium Metasilicate (62144) 01D1PA411-200	EA	2
		Sodium Metabisulfate (62144) 01PVM-0003-200	EA	2
		Citric Acid (62144) 01S1PA403-200	EA	2
		Filter Element, Fluid (62144) 04E-0PF307-020)	EA	2
		Gasket LID Micron Fiber (62144) 04F-SP1025-300	EA	2
		Gasket LID Micron Pub. (62144) 04F-SP25Z1-200	EA	2
		Gasket Strainer LID (62144) 04S-010RWS-003	EA	2
		Parts Kit, Water Chemical (62144) 06C-0VM500-000	EA	1



APPENDIX B

Section II. COMPONENTS OF END ITEMS  
ON-BOARD SPARES-Continued

(1) Illus Number	(2) National Stock Number	(3) Description FSCM and Part Number	(4) Usable On Code U/I	(5) Qty Req
		Kit High Pressure Pump (62144) 06W-SS1051-010	EA	1
		Belt, V (62144) 10B-00BX36-000	EA	2
		Fuse 250V/2.5A (62144) 20F-111032-025	EA	2
		Salinity Probes (62144) 20P-102682-000	EA	2
		Fuse, Cartridge (54426) F02A250V2-1-2A	EA	6
		<u>FUNCTION GROUP 08- COMPRESSED AIR SYSTEM</u>		
		Belt-V (49576) 110258B081	EA	2
		Filter Element, Intake Air Cleaner (49576) 110377E150	EA	2
		Filter Element, Fluid (49576) 110814-001	EA	2
		Filter (49576) 110827-050-3	EA	1
		Bearing, Sleeve (49576) 160005	EA	2
		Gasket (49576) 1852	EA	1
		Gasket (495760) 5502	EA	1
		Gasket (49576) 5827	EA	1
		Gasket (49576) 6680	EA	1

APPENDIX B

Section II. COMPONENTS OF END ITEMS  
ON-BOARD SPARES-Continued

(1) Illus Number	(2) National Stock Number	(3) Description FSCM and Part Number	(4) Usable On Code U/I	(5) Qty Req
		Gasket (49576) 6682	EA	1
		Valve Assembly, Compressor (49576) 7271X	EA	1
		Valve Assembly (49576) 7277X	EA	1
		Bearing, Sleeve (36232) P-90-A-213T-25	EA	1
		Bearing, Sleeve (36232) P-90-A-213T-35	EA	1
		<u>FUNCTION GROUP 09 - STEERING SYSTEM</u>		
		Packing Assembly (37919) 11-406012	EA	1
		Filter Element, Fluid (62983) 573083	EA	1
		Insert, Coupling (37919) 81-937005	EA	1
		Vane Set (62983) 923493	EA	1
		Coil Assembly (62983) 942470	EA	1
		<u>FUNCTION GROUP 10 - BOW RAMP WINCH</u>		
		Filter Element, Fluid (62983) 941190	EA	2
		Filter Element, Fluid (23619) HA-FS-20	EA	2
		Filter, Return Assembly (62983) OFRS-60-S-3M-PC-C10	EA	1

APPENDIX B

Section II. COMPONENTS OF END ITEMS  
ON-BOARD SPARES-Continued

(1) Illus Number	(2) National Stock Number	(3) Description FSCM and Part Number	(4) Usable On Code U/I	(5) Qty Req
		<u>FUNCTION GROUP 11 - MARINE SANITATION</u>		
		Anode, Corrosion Preventor (58568) 3500041	EA	2
		Pump Assembly Macerator (58568) 3500110	EA	1
		Bearing, Motor Fan End (58568) 3700039-004	EA	1
		Kit, Cutter Blade (58568) 3700039-007	EA	1
		Capacitor (58568) 3700039-012	EA	1
		Motor Assembly (58568) 3700039-042	EA	1
		Seal Set (58568) 3700039-75	EA	1
		Level Sensor Assembly (58568) 3700048	EA	1
		<u>FUNCTION GROUP 12 - FIRE PUMPS</u>		
		Bearing, Ball, Annular (90785) 1104454	EA	1
		Packing (90785) 2617307	EA	2
		Packing,. Performed (90785) 2617568	EA	2
		Impeller, Pump, Centrifugal (90785) 2669112	EA	1
		Casket (90785) 2669833	EA	2

APPENDIX B

Section II. COMPONENTS OF END ITEMS  
ON-BOARD SPARES-Continued

(1) Illus Number	(2) National Stock Number	(3) Description FSCM and Part Number	(4) Usable On Code U/I	(5) Qty Req
		Packing, Performed (90785) 2669940	EA	2
		Packing, Performed (90785) 2669942	EA	10
		Bearing, Ball, annular (90785) 2669989	EA	1
		Packing, Performed (90785) 2673291	EA	2
		Gasket (90785) 2673292	EA	2
		Gasket (90785) 2685966	EA	2
		Bearing, Washer, Thrust (05472) 40F76Y56-72014	EA	1
		Bearing, Ball, Annular (05472) 40F76Y56-72053	EA	1
		Bearing Ball, Annular (05472) 40F76Y56-72054	EA	1
		<u>FUNCTION GROUP 14-GYRO/ MAG COMPASS</u>		
		Lamp, Incandescent (54121) BL10ITEM 23	EA	5
		Fuse, Cartridge (81349) F03A250V1 AS	EA	9
		Fuse, Cartridge (81349) F03A250V8AS	EA	4
		Fuse, Cartridge (3AMP) (81349) F60C500V3A	EA	4

APPENDIX B

Section II. COMPONENTS OF END ITEMS  
ON-BOARD SPARES-Continued

(1) Illus Number	(2) National Stock Number	(3) Description FSCM and Part Number	(4) Usable On Code U/I	(5) Qty Req
		<u>FUNCTION GROUP 15- BOW ANCHOR WINDLASS</u>		
		Solenoid, Electrical (16954) 120-11058	EA	1
		Gage, Pressure, Dial (62901) 25-310-0-5000	EA	1
		Cartridge (54035) CGEH-WN	EA	2
		Valve, Hydraulic (54035) CBEH-LJN-YHL	EA	1
		Gasket, Inspection Cover (9Z225) HH80-3786-2	EA	1
		Nut, Self-Locking, Hexagon (67121) MSW-112-TH-024	EA	50
		Valve Relief (54846) RV2-10	EA	1
		<u>FUNCTION GROUP 16- STERN ANCHOR &amp; WINCH</u>		
		Screw, Brass (67121) 540-HAW-1 5/7.5-024	EA	50
		Nut, Self-Locking, Hexagon (67121) 540-HAW-15/7.5-25	EA	50
		Gasket Kit (04720) PK679	EA	1
		Kit, Performed Packing (04720) PK931	EA	1
		Kit, Stack (04720) PK932	EA	1
		Kit, Bearing (04720) PK974	EA	1

APPENDIX B

Section II. COMPONENTS OF END ITEMS  
ON-BOARD SPARES-Continued

(1) Illus Number	(2) National Stock Number	(3) Description FSCM and Part Number	(4) Usable On Code U/I	(5) Qty Req
		Element, Filter (60827) SE-10	EA	3
		<u>FUNCTION GROUP 17 - HVAC/ENVIRONMENTAL</u>		
		Capacitor, Motor (91764) 017-A-009	EA	1
		Compressor (91764) 020-A-109	EA	1
		Coil, Solenoid (91764) 025-A-014	EA	1
		Filter, Air (91764) 030-A-052	EA	5
		Motor, Electric, Alternating (91764) 050-A-106	EA	1
		Relay, Electromagnetic (91764) 059-A-119	EA	1
		Valve, Plate Assembly (10855) 06-D-75-163	EA	1
		Switch, High Pressure (91764) 066-A-039	EA	1
		Switch, High Pressure (91764) 066-A-059	EA	1
		Tubing, Capillary (91764) 067-D-117	EA	1
		Valve, Charging (91764) 068-A-031	EA	1
		Valve, Water By-Pass (91764) 068-A-038	EA	1
		Valve, Water (91764) 068-A-067	EA	1

**APPENDIX B  
SECTION II. COMPONENTS OF END ITEMS ON-BOARD SPARES - CONT**

(1) ILLUS NO.	(2) NATIONAL STOCK NUMBER	(3) DESCRIPTION FSCM AND PART NUMBER	(4) USABLE ON CODE U/M	(5) QTY REQ'D
		Strainer, Suction Assembly (10855) 06DA-402-133	EA	1
		Thermostat (10855) 06DA-660-055	EA	1
		Valve, Package Discharge (10855) 06DA660062	EA	1
		Valve, Package Suction (10855) 06EA60090	EA	1
		Filter (94674) 16X20X2	EA	4
		Motor, Alternating Current (65586) 193-130381-002	EA	1
		Bearing (05472) 2.05	EA	1
		Bearing, Ball, Annular (05472) 203	EA	1
		Thermostat (65586) 300-0479197-003	EA	1
		Switch, Thermostatic (65586) 300-049200-001	EA	1
		Valve, Pressure Relief (58553) 3014	EA	1
		Fuse, Cartridge (83750) 40526001	EA	4
		Probe, Air (83750) 41653001	EA	2
		Bearing, Ball (38443) 416821-2D	EA	2
		Bearing, Ball (38443) 416821-3FX	EA	1

**APPENDIX B**  
**SECTION II. COMPONENTS OF END ITEMS ON-BOARD SPARES - CONT**

(1) ILLUS NO.	(2) NATIONAL STOCK NUMBER	(3) DESCRIPTION FSCM AND PART NUMBER	(4) USABLE ON CODE U/M	(5) QTY REQ'D
		Reset, Capillary Manual Limit (83750) 41984011	EA	1
		Reset, Capillary Automatic Limit (53750) 50025003	EA	1
		Switch, Airflow (83750) 51085002	EA	2
		Valve, Assembly Relief (10855) 6-D-23-522	EA	1
		Screen Oil Strainer (10855) 6-D-40-103	EA	1
		Gasket (10855) 6-D-40-1061	EA	1
		Valve, Safety Relief (10855) 6-D-40-162	EA	1
		Head Compressor (10855) 6-D-40-2163	EA	2
		Ring, Retaining (10855) 6-D-43-1651	EA	6
		Pin, Piston (10855) 6-D-43-1661	EA	2
		Gasket (10855) 6-D-68-1043	EA	6
		Gasket (10855) 6-D-68-1053	EA	6
		Head, Pump & Bearing Assembly (10855) 6-D-68-952	EA	1



## APPENDIX B

Section II. COMPONENTS OF END ITEMS  
ON-BOARD SPARES-Continued

(1) Illus Number	(2) National Stock Number	(3) Description FSCM and Part Number	(4) Usable On Code U/I	(5) Qty Req
		Piston Compressor (10855) 6-D-75-181	EA	2
		Piston, Compressor (10855) 6-D-75-2043	EA	2
		Spring, Check Valve (10855) 6-D-75-2081	EA	1
		Valve Plate, Package (10855) 6-D-75-253	EA	2
		Casket (10855) 6-D-75-2672	EA	2
		Crankshaft, Compressor (10855) 6-D-75-722	EA	1
		Casket Set (10855) 6-D643-172	EA	1
		Casket (10855) 6-F-25-1013	EA	1
		Indicator, Moisture Liquid (58553) 60-145	EA	1
		Bearing, Pillow Block (35197) 716625-01	EA	2
		Bearing (05472) 716625-03	EA	2
		Belt, V (35197) 725469-51	EA	2
		Belt, V (35197) 725537-34	EA	2
		Belt, V (35197) 725537-39	EA	1
		Belt, V (35197) 725537-50	EA	1

APPENDIX B

Section II. COMPONENTS OF END ITEMS  
ON-BOARD SPARES-Continued

(1) Illus Number	(2) National Stock Number	(3) Description FSCM and Part Number	(4) Usable On Code U/I	(5) Qty Req
		Thermostat, Cooling (50831) A19ABC-74	EA	1
		Ring, Piston (10855) AU-50CP-245	EA	2
		Ring, Piston (10855) AU-50CP-355	EA	2
		Gasket (10855) AU-51YA-011	EA	1
		Contactora, Control (74924) C123-021	EA	1
		Contactora, Control (74924) C133-011	EA	1
		Switch, Thermostatic (74924) C231-042	EA	1
		Transformer, Control (74924) C316-022	EA	1
		Motor, AC (7E229) C0G4B	EA	1
		Gasket, Element (74924) F121-011	EA	6
		Belt (94674) LSC-106-2	EA	2
		Fuse, Cartridge (74924) OT-20	EA	11
		Switch, Pressure (50831) P28DA-1	EA	1
		Thermostatic, Manual Reset (49472) VDH-212153M	EA	1

**APPENDIX B**  
**SECTION II. COMPONENTS OF END ITEMS ON-BOARD SPARES - CONT**

(1) ILLUS NO.	(2) NATIONAL STOCK NUMBER	(3) DESCRIPTION FSCM AND PART NUMBER	(4) USABLE ON CODE U/M	(5) QTY REQ'D
		<b><u>Halon &amp; Firefighting - Furnishings &amp; Entertainment</u></b>		
		Gasket Rubber Ring (80871) 0007-1989-750	EA	1
		Gasket (80871) 0007-2387-750	EA	1
		Bearing, Alarm Control (80871) 1.60	EA	1
		Fuse, Roller Contact (71400) 15483	EA	5
		Seal, Stud (25204) 201333	EA	1
		Fuse, Cartridge (04034) 32348	EA	5
		Lamp, Incandescent (04034) 36843	EA	5
		Transformer, Power (04034) 37652	EA	1
		Lamp, Neon (95277) 41021	EA	5
		Fuse (10741) 4110A3	EA	5
		Fuse, Cartridge (10741) 4113A30	EA	5
		Power Supply (04034) 41415	EA	1
		Lamp, Incandescent (73274) 42	EA	5

**APPENDIX B**  
**SECTION II. COMPONENTS OF END ITEMS ON-BOARD SPARES - CONT**

(1) ILLUS NO.	(2) NATIONAL STOCK NUMBER	(3) DESCRIPTION FSCM AND PART NUMBER	(4) USABLE ON CODE U/M	(5) QTY REQ'D
		Capacitor, Fixed, Electrolytic (10741) 4405	EA	1
		Relay, Electromagnetic (10741) 4722	EA	1
		Relay, Solid State (55442) 480D10-12	EA	1
		Fuse, Cartridge (53918) 50016	EA	5
		Fuse, Cartridge (28199) 5290-00-518-1793	EA	10
		Fuse, Cartridge (28199) 5920-00-243-3787	EA	5
		Bearing, Roller Contact (80871) 6.10	EA	1
		Filter Element, Fluid (25204) 600616	EA	2
		Filter Element, Fluid (25204) 60017	EA	1
		Filter Element, Fluid (53198) 614-505	EA	6
		Element Coalescer (53198) 622-100	EA	1
		Lamp, Cartridge (53918) 81007	EA	5
		Lamp, Incandescent (61204) 90400172	EA	10
		Lamp, Tungsten (61204) 90400290	EA	1

**APPENDIX B**  
**SECTION II. COMPONENTS OF END ITEMS ON-BOARD SPARES - CONT**

(1) ILLUS NO.	(2) NATIONAL STOCK NUMBER	(3) DESCRIPTION FSCM AND PART NUMBER	(4) USABLE ON CODE U/M	(5) QTY REQ'D
		Gasket (61204) 95800146	EA	2
		Lamp, Xenon (10741) 9800	EA	2
		Lamp, Incandescent (95405) A-19 (100W)	EA	1
		Fuse, Cartridge (81349) FO3A250V3AS	EA	10
		Fuse, Cartridge (81349) FO3A250V10AX	EA	5
		Fuse, Cartridge (81349) FO3A250V2AS	EA	5
		Gasket, Lens (95405) GKT1005	EA	1
		Gasket, Top (95405) GKT1032	EA	1
		Light, Indicator (81349) LH89/1-LC35RT2	EA	1
		Fuse, Cartridge (71400) MDL-1/2	EA	5
		Gasket (75214) PT121-1	EA	1
		<b><u>Function Group 1804 - Separators/Purifiers</u></b>		
		Switch, Level (53918) 5X77	EA	1
		Contacto (3N065) LCI=ECO3M	EA	1

**APPENDIX B**  
**SECTION II. COMPONENTS OF END ITEMS ON-BOARD SPARES - CONT**

(1) ILLUS NO.	(2) NATIONAL STOCK NUMBER	(3) DESCRIPTION FSCM AND PART NUMBER	(4) USABLE ON CODE U/M	(5) QTY REQ'D
		<p><b><u>Function Group 1806 - Tank Level Indicators</u></b></p> <p>Fuse, Alarm Control (71400) 15483</p> <p>Fuse, Cartridge (04034) 32348</p> <p>Fuse, Cartridge (81349) F03A250V2AS</p> <p><b><u>Function Group 1807 - Navigation/Non-Electrical</u></b></p> <p>Fuse, Cartridge (81349) F03A250V10AS</p> <p>Fuse, Cartridge (81349) F03A250V3AS</p> <p>Contact Kit (75214) P263-1</p> <p><b><u>Function Group 1808 - Machine Shop Equipment</u></b></p> <p>Fuse (96073) 0828-2395</p> <p><b><u>Function Group 1809 - Commissary Laundry</u></b></p> <p>Belt, Pump (59618) 27155</p> <p>Belt, Agitate and Spin (59618) 28808</p> <p><b><u>Function Group 1810 - Miscellaneous Pumps</u></b></p> <p>Coupling, Spider (70834) L75</p>	EA  EA EA  EA EA EA  EA  EA EA  EA	2  2 2  4 4 1  4  1 1  1

APPENDIX B

Section II. COMPONENTS OF END ITEMS  
ON-BOARD SPARES-Continued

(1) Illus Number	(2) National Stock Number	(3) Description FSCM and Part Number	(4) Usable On Code U/I	(5) Qty Req
		<u>FUNCTION GROUP 1811- CONTROLS/SWITCHBOARDS</u>		
		Valve, Shuttle (88233) 03650-9001	EA	1
		Fuse (37919) 420-001	EA	5
		Valve, Quick Exhaust (88233) 3077-9500	EA	1
		Valve, 3 Way (88233) 41462-1000	EA	1
		Sensor, Level (77396) 61-1700-003	EA	1
		Sensor, Level (77396) 61-2050-000	EA	1
		Sensor, Pressure (77396) 62-2300-000	EA	1
		Sensor, Pressure (77396) 62-2150-000	EA	1
		Sensor, Pressure (77396) 62-2100-000	EA	1
		Sensor, Pressure (77396) 62-2061-000	EA	1
		Sensor, Pressure (77396) 62-2500-000	EA	1
		Sensor, Temperature (77396) 62-6005-001	EA	1
		Sensor, Temperature (77396) 62-6009-001	EA	1
		Sensor, Temperature (77396) 62-6007-001	EA	1

APPENDIX B

Section II. COMPONENTS OF END ITEMS  
ON-BOARD SPARES-Continued

(1) Illus Number	(2) National Stock Number	(3) Description FSCM and Part Number	(4) Usable On Code U/I	(5) Qty Req
		Fuse, 1 Amp (73396) 68-00009-001	EA	5
		Fuse, 3 Amp (73396) 68-00009-003	EA	5
		Fuse, 3 Amp (73396) 91-6009-003	EA	1
		Governor, Actuator (88233) B202-1009	EA	1
		Throttle, Interlock (88233) F011-126	EA	1
		Valve, Rotary, Dir (88233) F011-126	EA	1
		Valve, Rotary, Dir (88233) F041 -003	EA	1
		Fuse Cartridge (71400) FRN5	EA	2
		Valve, 3 Way (88233) H404-31 093	EA	1
		Valve, Linear, Dir (88233) M000-20362	EA	1
		Valve, Linear, Dir (88233) M085-318-26	EA	1
		<u>FUNCTION GROUP 1812</u> <u>-ELECTRICAL SYSTEMS</u>		
		Lamp, Fluorescent (85405) F15T8	EA	6



## APPENDIX B

Section II. COMPONENTS OF END ITEMS  
ON-BOARD SPARES-Continued

(1) Illus Number	(2) National Stock Number	(3) Description FSCM and Part Number	(4) Usable On Code U/I	(5) Qty Req
		Lamp, Fluorescent (95405) F8T5	EA	6
		Lamp, Mercury Vapor (95405) INX3520	EA	1
		Lamp, Mercury Vapor (95405) INX3524	EA	1
		Lamp, Incandescent (95405) INX3528	EA	1
		Fuse, Cartridge (92731) P8-A1-A130	EA	4
		Fuse, Cartridge (92731) P8-A1-A70	EA	4
		Fuse, Cartridge (92731) P8-C2-B35	EA	4
		Fuse, Cartridge (92731) P8-C2-B60	EA	4
		Thermostat (02185) T28DS	EA	1
		<u>Function Group 1815 - Work Boat/Life Boats/Davits</u>		
		Spark Plug (63931) 33-82372M	EA	2
		Element, Filter Fuel (63931) 35-11934M	EA	1
		Propeller Assembly (63931) 48-73134A4	EA	1
		Repair Kit, Boat (6A840) AV860	EA	1

APPENDIX B

Section II. COMPONENTS OF END ITEMS  
ON-BOARD SPARES-Continued

(1) Illus Number	(2) National Stock Number	(3) Description FSCM and Part Number	(4) Usable On Code U/I	(5) Qty Req
		<u>FUNCTION GROUP 1816- CONTROL SYSTEMS</u>		
		Fuse, Cartridge (32862) 1069895	EA	5
		Fuse, Cartridge (1A, 600V) (27192) 44-1687-16	EA	2
		Fuse, Cartridge (27192) 44-2074-12	EA	2
		Fuse, Cartridge (27192) 4-2074-23	EA	2
		Fuse, Cartridge (27192) 44-574	EA	2
		Fuse, Cartridge (27192) 44-576	EA	2
		Fuse, Cartridge (27192) 44-579	EA	2
		Fuse, Cartridge (73396) 68-00009-001	EA	5
		Fuse, Cartridge (73396) 91-6009-003	EA	1
		Fuse, Cartridge (250V, 3A) (OBVP5) BAF-3	EA	2
		Fuse, Cartridge (71400) FRNS	EA	1
		<u>FUNCTION GROUP 1819- PIPING SYSTEMS</u>		
		Valve, Globe, 150# Threaded Union Bonnet (1/2") (77408) 11-5490-1025	EA	1

## APPENDIX B

Section II. COMPONENTS OF END ITEMS  
ON-BOARD SPARES-Continued

(1) Illus Number	(2) National Stock Number	(3) Description FSCM and Part Number	(4) Usable On Code U/I	(5) Qty Req
		Fitting, Hose, Male Pipe (3/4"-14) (77408) 23-1148-5505	EA	2
		Connector, Hose (77408) 23-1292-5505	EA	2
		Fitting, Reusable, Compression Type, Brass (77408) 23-1445-5265	EA	2
		Gasket, (For 15 Old Flange, Synthetic Rubber) (77408) 27-0495-1070	EA	1
		Gasket, Ring, Synthetic Rubber (1/16" x 2") (77408) 27-0496-1060	EA	2
		Gasket Ring (77408) 27-0502-1055	EA	4
		Gasket Ring (77408) 27-0502-1060	EA	2
		Gasket (77408) 27-0901-1060	EA	2
		Gasket (77408) 27-2205-1050	EA	2
		Gasket, Full Face (150#, Synthetic) (77408) 27-2205-1080	EA	2
		Gasket (2-1/2") (77408) 27-2210-1055	EA	2
		Gasket, Full Face, D (150, Synthetic) (77408) 27-2425-1045	EA	2
		Gage, 0-100# (4-1/2" Dial:) (77408) 33-1745-1075	EA	1
		Gage, Pressure Range (77408) 33-1770-1075	EA	1

## APPENDIX B

Section II. COMPONENTS OF END ITEMS  
ON-BOARD SPARES-Continued

(1) Illus Number	(2) National Stock Number	(3) Description FSCM and Part Number	(4) Usable On Code U/I	(5) Qty Req
		Gage, Pressure (77408) 33-2870-1075	EA	3
		Fuses (42892) 5116	EA	2
		Anode (42892) 5206-39	EA	4
		Valve, Globe (3/8") (76364 572M	EA	1
		Valve, Globe (1/2") (76364) 572M	EA	1
		Valve, Globe (1") (76364) 572M	EA	1
		Valve, Globe Threaded (1/2") (77408) 590	EA	1
		Valve, Globe, 150# Threaded Union Bonnet 2" (77408) 590	EA	1
		Valve, Globe, 150# Threaded Union Bonnet (1-1/2") (77408) 590	EA	1
		Valve, Globe, 150# Threaded Union Bonnet 1" (77408) 590	EA	1
		Valve, Ball (3/4" Steel Threaded) (57661) 73-104	EA	4
		Valve, Globe, Stop Check Union Bonnet (3/4") (82666) B-39	EA	1

APPENDIX B

Section II. COMPONENTS OF ITEM LIST  
ON-BOARD SPARES

(1) ILLUS NO.	(2) NATIONAL STOCK NUMBER	(3) DESCRIPTION FSCM AND PART NUMBER	(4) USABLE ON CODE U/M	(5) QTY REQ'D
		Switch Pressure (Close 35 psi, Open 60 psi) (6J769) D2H-A80	EA	1
		Valve, Gate (82666) G-679-.75	EA	1
		DCA Test Kit (33457) CC2626	EA	1



## APPENDIX B

## Section III. BASIC ISSUE ITEMS-CONT

(1) ILLUS NUMBER	(2) NATIONAL STOCK NUMBER	(3) DESCRIPTION CAGEC and Part Number	Usable On Code	(4) U/I	(5) Qty rqr
	6545-00-911-1300	Blanket Set, Medical, Federal Sup Cat, C-6545-1L, Vol 2 (No ref)		SE	1
	7210-00-282-7950	Blanket, Bed, Wool, Type 1, Grade B, Size 2, 66" X 84" (81349) MIL-B-844		EA	30
	3940-00-892-4560	Block, Tackle, 3 1/2", Double Sheave, (81348) GGG-B-490		EA	2
	3940-00-068-9173	Block, Tackle, 4 1/2", Double Sheave, (81348) GGG-B490		EA	2
	4140-01-039-9845	Blower, Ventilating, Portable (27020) GE-V8		EA	1
	7330-00-078-5706	Board, Food Chopping, 15" X 20" X 3/4" (81348) LLL-B-568		EA	1
	7330-00-685-5013	Bowl Set, Food, Mixing, 3 Pc, Stainless Steel (81348) RR-B-1242		SE	1
	7350-00-251-8746	Bowl, Eating, Plastic, 5 3/4" dia, 2 9/16" deep, Class 2, Item 4 (81348) L-T-48		DZ	2
	7330-00-262-2323	Bowl, Food, Mixing, Stainless Steel, 5 qt, 11" dia, 4 7/8" deep, (81348) RR-B-1242		EA	2
	7330-00-241-8168	Bowl, Food, Mixing, Stainless Steel, 7 1/2 gal, 21 3/4" dia, 8 3/4" deep, (81349) MIL-B-2054		EA	1
		Box, Binocular, Type W-8 (00096) 531C		EA	2
	5140-00-587-5558	Box, Tool, Type 3, Class 2 (81348) GGG-T-558/3		EA	1
		Brake Spring Installer (59618) 242P4		EA	1
	4240-00-616-2857	Breathing Apparatus, Oxygen Generating, with Canisters and Carrying Case, Navy Type A4 (81349) MIL-B-51254		EA	6
	5210-00-229-3054	Calipers, General Purpose, Outside, Thread, 0" to 6", Type 2, Class 5 (81348) GGG-C-95		EA	2
	5210-00-221-1921	Caliper, Micrometer, Inside, 2" to 12", Type 2, Class 2 (81348) GGG-C-105			
	5210-00-554-7134	Caliper, Micrometer, Outside, 0" to 6", Type 1, Class 1, Style A (81348) GGG-C-105		EA	1
		Camshaft Installation Pilots (15434) 3375268		EA	1
	7240-00-256-7700	Can, Flammable, Waste, Foot Operated, 10 gal (81348) RR-C-114		EA	2
	7240-00-222-3088	Can, Gasoline, 5 gal (81348) MIL-C-1283		EA	5
	4240-00-174-1365	Canister, Oxygen Generating, Breathing Apparatus (81349) MIL-C-17671		EA	54

## APPENDIX B

## Section III. BASIC ISSUE ITEMS-CONT

(1) ILLUS NUMBER	(2) NATIONAL STOCK NUMBER	(3) DESCRIPTION CAGEC and Part Number	Usable On Code	(4) U/I	(5) Qty rqr
	5120-00-529-4124	Carrier, Storage Battery, Type 2, Class A, Size20 (81348) GGG-C-1968		EA	1
	6645-00-290-2232	Case, Chronometer, Gimbal (no ref)		EA	1
	7105-00-269-8463	Chair, Folding, Metal, Gray, Steel, Overall, Type 1, Class 1, Style A (81348)AA-C-291		EA	1
	7110-00-273-8782	Chair, Office, Straight, with Arms, Type 1, Style A (81348) AA-C-00293		EA	AR
	7110-00-273-8785	Chair, Straight (81348) AA-C-00293		EA	AR
	5110-00-554-7345	Chisel, Cape, Heavy Duty, 6 ¾" X ¼", Type 1, Style B (81348) GGG-C-313		EA	3
	5110-00-236-3273	Chisel, Cold, Hand, 7 ½" X 7/8", Type 4, Class 1(81348) GGG-C-313		EA	3
	5130-00-203-6424	Chisel, Power Hammer, Scaling, 1¼" X 9" RD Shank Type 15, Class A (81348) GGG-C-330		EA	2
	6645-01-282-1928	Chronometer (54121) MQ-2		EA	1
	5120-00-529-3744	Clamp, "C", Heavy, 4 ½" to 2 ¾" (81348) GC-406		EA	2
	7910-00-551-6854	Cleaner, Vacuum, ac/dc, 120V, 60 Hz, Single Phase, 1.5 hp(81348) W-C-421		EA	4
	6605-00-825-5618	Clinometer, Ship, Heel, Type 1, Class A (81349) MIL-C-20061		EA	2
	6605-00-818-3897	Clinometer, Ship, Trim, Type 2 (81349) MIL-C-20061		EA	2
	6645-00-935-7046	Clock Mechanical, Marine, 8-day, Sweep Second Hand (81349) MIL-C-1194		EA	2
		Coffee Maker (25628) Model OT15		EA	1
	5120-01-046-4979	Comb Wrench Set (55719) GOEXM-714		EA	1
	4910-01-171-3914	Connect Rod Guide Pins (15434) 3375098		EA	4
	4910-01-165-6016	Connect Rod Guide Pins (15434) 3375601		EA	4
	5120-00-224-1390	Crowbar, Pinpoint, 1 ¼" dia, 59" to 62" Long, Type 2, Class 1, Size 4 (81348) GGG-B-101		EA	1
	7350-00-935-6635	Cruet, Condiment, 6 oz (81348) DD-T-101		EA	3
	7350-00-223-7760	Cup, Drinking, Plastic, 10 oz (81348) L-T-48		DZ	2
	7350-00-823-7563	Cup, Drinking, Glass, 10 -½ oz (81348) DD-T-90		DZ	3
	7350-00-823-7563	Cup, Drinking, Glass, 6 -½ oz (81348) DD-T-90		DZ	2
	5180-00-596-1038	Cutter and Flaring Tool Kit, 1/8" to 1-1/8" Cut Range, 3/16" to ¾" Swaging, Type 2, Class 1 (81348) GGG-C-771		KT	1



## APPENDIX B

## Section III. BASIC ISSUE ITEMS-CONT

(1) ILLUS NUMBER	(2) NATIONAL STOCK NUMBER	(3) DESCRIPTION CAGEC and Part Number	Usable On Code	(4) U/I	(5) Qty rqr
	5110-00-188-2524	Cutter, Bolt, Rigid, Clipper, 36" Long, Type 2, Class 4 (81348) GGG-C-740		EA	1
	7330-00-633-8904	Cutter, Doughnut, Steel, 3" (81349) MIL-C-40115		EA	1
	5110-00-293-0460	Cutter, Pipe, Wheel Type, Cuts 1/8" to 2" dia, Type 1, Class 1, Style B (81348) GGG-C-771		EA	1
	5120-01-262-7309	Cylinder Liner Clamp Set (15434) 3822503		EA	1
	5120-00-999-1206	Cylinder Liner Driver (15434) ST-1229		EA	1
	4910-01-171-3915	Cylinder Liner Installer (15434) 3375422		EA	1
	5120-01-143-2032	Cylinder Liner Puller (15434) 3376015		EA	1
	6665-00-903-4767	Detector kit, Chemical Agent, Sup Cat MAN-6665-94-CL-E14 (81361) E5-77-2092		EA	1
	6665-00-618-1482	Detector Kit, Carbon Monoxide, Colormetric (81349) MIL-D-3945		EA	2
	7330-00-272-2488	Dipper, Kitchen, Cres, 1 pt, 8" Handle, Size 1(81348) RR-D-400		EA	2
	7350-00-823-7398	Dish, Eating, 5-9/16" dia (81348) DD-T-90		DZ	2
	7330-00-190-5190	Dishpan, Round, Stainless Steel, 20 qt (81348) RR-D-450		EA	1
	7350-00-205-0928	Dispenser, Paper Napkins, Stainless Steel, 125 Capacity (81348) RR-D-500		EA	3
	4510-00-585-6305	Dispenser, Paper Towel, Steel Cabinet, Type 3 (81348) WW-D-1909		EA	1
	7350-00-641-6050	Dispenser, Sugar, 12 oz, Glass Body, Stainless Steel Cap with Flip Opening (81348) DD-T-101		EA	3
	6605-00-025-7005	Divider Set, Navigation, Time-Speed (80064) S2407-H-533623		SE	1
	5210-00-266-7038	Divider, Mechanics, Solid Nut Adj, 4", Type A, Class 2 (81348) GGG-D-351		EA	1
	7330-00-205-3154	Double Boiler, Domestic, Aluminum, 3 qt (81348) RR-B-500		EA	1
	7330-00-984-4065	Double Boiler, Institutional, 5-½ qt (81348) RR-B-500		EA	1
	5130-00-293-1849	Drill, Elcl, Portable, Type 3, Class A, 650 rpm, 112" cap, Heavy Duty, ac/dc, 115V (81348) W-D-661		EA	1
	5130-00-473-6224	Drill, Elcl, Portable, 3/8" cap, Class C, Style1 (81348) W-D-661		EA	1

## APPENDIX B

## Section III. BASIC ISSUE ITEMS-CONT

(1) ILLUS NUMBER	(2) NATIONAL STOCK NUMBER	(3) DESCRIPTION CAGEC and Part Number	Usable On Code	(4) U/I	(5) Qty rqr
	5133-00-293-0983	Drill Set, Twist, Set 2, Str Short Shank, Set of 29, Frac Sizes 1/16" to 1/2" by 64ths (81348) GGG-D-751		SE	2
	7290-00-224-8308	Dustpan, Steel, Type 2, Class 2, Size 12 (81348) RR-D-800		EA	7
	4320-00-256-8206	Educator, Bilge, 4" (Ejector, Jet) (71905) 48S011		EA	2
	7330-00-815-3408	Egg Beater, Handcrank, Double Beaters Heavy Duty, Type 1 (81348) RR-E-300		EA	1
	6730-00-815-1458	Egg Whip, Stainless Steel, 16" Long, 3" dia, Item 7, Size 3 (81348) RR-Q456		EA	1
	3940-01-183-9412	Engine Lifting Sling (15434) 3375958		EA	1
	5120-01-171-3952	Expander, Piston Ring (15434) ST-1269		EA	1
	4220-01-251-6466	Exposure/Survival Suit, Adult Universal		EA	23
	2040-00-565-9124	Fender, Marine 18"dia (81996) 2040F2-013		EA	1
	5120-00-223-8860	Fid, 18" Long, Type 1, Style A (81349) MIL-F-3113		EA	2
	5120-01-262-7305	Filter Cutter (15434) 3376579		EA	1
	4910-00-999-1269	Fixture, Timing		EA	1
	8345-00-262-2419	Flag, Identification, Vessel, Transportation Corps, Type 1, Class 2, Fly=3', Hoise=2' (81349) MIL-F-2692		EA	1
	8345-00-656-1446	Flag, National, Union Jack, 1'10" X 2'8" (81348) DDD-F-416		EA	2
	8345-00-245-2040	Flag, National, United States, 1'6" X 2'8" (81348) DDD-F-416		EA	2
	8345-00-935-0445	Flag, Signal, 'A' Intn'l Code, Size 6 (81349) MIL-F-2692		EA	2
	8345-00-926-6803	Flag, Signal, 'B' Intn'l Code, Size 6 (81349) MIL-F-2692		EA	2
	8345-00-935-0446	Flag, Signal, 'C' Intn'l Code, Size 6 (81349) MIL-F-2692		EA	2
	8345-00-926-6805	Flag, Signal, 'D' Intn'l Code, Size 6 (81349) MIL-F-2692		EA	2
	8345-00-935-0447	Rag, Signal, 'E' Intn'l Code, Size 6 (81349) MIL-F-2692		EA	2
	8345-00-926-9218	Flag, Signal, 'P' Intn'l Code, Size 6 (81349) MIL-F-2692		EA	2

Pages B-47 through B-50 are deleted

Change 4 B-46

## APPENDIX B

## Section III. BASIC ISSUE ITEMS LIST-CONT

(1) ILLUS NO.	(2) NATIONAL STOCK NUMBER	(3) DESCRIPTION FSCM AND PART NUMBER	(4) USABLE ON CODE U/M	(5) QTY REQ'D
	5180-00-596-1038	Cutter and Flaring Tool Kit, 1/8" - 1-1/8" Cut Range, 3/16" to 3/4" Swaging, Type 2, Class 1 (81348) GGG-C-771	KT	1
	5110-00-188-2524	Cutter, Bolt Rigid, Clipper 36" Long, Type 2, Class 4 (81348) GGG-C-740	EA	1
	7330-00-633-8904	Cutter, Doughnut, Steel 3 in (81349) MIL-C-40115	EA	1
	5110-00-293-0460	Cutter, Pipe, Wheel Type, Cuts 1/8" to 2" dia, Type 1, Class 1, Style B (81348) GGG-C-771	EA	1
	5120-01-262-7309	Cylinder Clamp Set (15434) 3822503	EA	1
	5120-01-262-7309	Cylinder Liner Clamp Set (15434) 3822503	EA	
	5120-00-999-1206	Cylinder Liner Driver (15434) ST-1229	EA	1
		Cylinder Liner Driver (15434) ST-1229	EA	1
	4910-01-171-3915	Cylinder Liner Installer (15434) 3375422	EA	1
	4910-01-171-3915	Cylinder Liner Installer (15434) 3375422	EA	1
	5120-01-143-2032	Cylinder Liner Puller (15434) 3376015	EA	1
	2090-01-064-8020	Damage Control Kit, Shipping Data, Each Kit has 1 pkg, 820 lb, 72 cu ft Lumber, 590 lb, 21 cu ft (192" x 12") (81996) TL-E1-80278	KT	1

## APPENDIX B

## Section III. BASIC ISSUE ITEMS LIST-CONT

(1) ILLUS NO.	(2) NATIONAL STOCK NUMBER	(3) DESCRIPTION FSCM AND PART NUMBER	(4) USABLE ON CODE U/M	(5) QTY REQ'D
	6665-00-903-4767	Detector Kit, Chemical Agent, Sup MAN-6665-94-CL-E14 (81361) E5-77-2092	EA	1
	6665-00-618-1482	Detector Kit, Carbon Monoxide, Colormetric (81349) MIL-D-3945	EA	2
	7330-00-272-2488	Dipper, Kitchen, Cres, 1 pt, 8" Handle, Size 1 (81348) RR-D-400	EA	2
	7350-00-823-7398	Dish, Eating, 5-9/16" dia (81348) DD-T-90	DZ	2
	7330-00-190-5190	Dishpan, Round, Stainless Steel, 20 qt (81348) RR-D-450	EA	1
	7350-00-205-0928	Dispenser, Paper Napkins, Stainless Steel, 125 capacity (81348) RR-D-500	EA	3
	4510-00-585-6305	Dispenser, Paper Towel, Steel Cabinet, Type 3 (81348) WW-D-1909	EA	1
	7350-00-641-6050	Dispenser, Sugar, 12 oz, Glass Body, Stainless Steel Cap w/Flip Opening (81348) DD-T-101	EA	3
	6605-00-025-7005	Divider Set, Navigation Time-Speed (80064) 52407-H-533623	SE	1
	5210-00-266-7038	Divider, Mechanics, Solid Nut Adj, 4", Type A, Class 2 (81348) GGG-D-351	EA	1
	7330-00-205-3154	Double Boiler, Domestic, Aluminum, 3 qt (81348) RR-B-500	EA	1

## APPENDIX B

## Section III. BASIC ISSUE ITEMS LIST-CONT

(1) ILLUS NO.	(2) NATIONAL STOCK NUMBER	(3) DESCRIPTION FSCM AND PART NUMBER	(4) USABLE ON CODE U/M	(5) QTY REQ'D
	7330-00-984-4065	Double Boiler, Institutional, 5-½ qt (81348) RR-B-500	EA	1
	5130-00-293-1849	Drill Elcl, Portable, Type 3, Class A, 650 rpm, ½" Cap, Heavy Duty ac/dc, 115V (81348) W-D-661	EA	1
	5130-00-473-6224	Drill Elcl, Portable, 3/8" Cap, Class C, Style 1 (81348) W-D-661	EA	1
	5133-00-293-0983	Drill Set, Twist, Set 2, Str Short Shank, Set of 29, Frac Sizes, 1/16"-½" by 64ths (81348) GGG-D-751	SE	2
	7290-00-224-8308	Dustpan, Steel, Type 2, Class 2, Size 12 (81348) RR-D-800	EA	7
	4320-00-256-8206	Educator, Bilge, 4" (Ejector, Jet) (71905) 48S011	EA	2
	7330-00-815-3408	Egg Beater, Handcrank, Double Beaters, Heavy Duty, Type 1 (81348) RR-E-300	EA	1
	6730-00-815-1458	Egg Whip, Stainless Steel, 16" Long, 3" dia, Item 7, Size 3 (81348) RR-Q-456	EA	1
	3940-01-183-9412	Engine Lifting Sling (15434) 3375958	EA	1
	5120-01-171-3952	Expander Piston Ring (15434) ST-1269	EA	1
	6730-01-116-1620	Exposure Suit Use NSN 8415-01-136-5446, Survival Suit, Adult	EA	15
	2040-00-565-9124	Fender, Marine 18" dia (81996) 2040F2-013	EA	14

## APPENDIX B

## Section III. BASIC ISSUE ITEMS LIST-CONT

(1) ILLUS NO.	(2) NATIONAL STOCK NUMBER	(3) DESCRIPTION FSCM AND PART NUMBER	(4) USABLE ON CODE U/M	(5) QTY REQ'D
	5120-00-223-8860	Fid, 18" Long, Type 1, Style A (81349) MIL-F-3113	EA	2
	5120-01-262-7305	Filter Cutter (15434) 3376579	EA	1
	4910-00-999-1269	Fixture Timing (15434) 3375522	EA	1
	8345-00-262-2419	Flag, Identification Vessel, Transportation Corps, Type 1, Class 2, Fly=3', Hoise=2' (81349) MIL-F-2692	EA	1
	8345-00-656-1446	Flag, National, Union Jack 1'10" x  (81348) DDD-F-416	EA	2
	8345-00-245-2040	Flag, National, United States 1'6" x 2'8" (81348) DDD-F-416	EA	2
	8345-00-935-0445	Flag, Signal, "A" Intn'l Code, Size 6 (81349) MIL-F-2692	EA	1
	8345-00-926-6803	Flag, Signal, "B" Intn'l Code, Size 6 (81349) MIL-F-2692	EA	2
	8345-00-935-0446	Flag, Signal, "C" Intn'l Code, Size 6 (81349) MIL-F-2692	EA	2
	8345-00-926-6805	Flag, Signal, "D" Intn'l Code, Size 6 (81349) MIL-F-2692	EA	2
	8345-00-935-0447	Flag, Signal, "E" Intn'l Code, Size 6 (81349) MIL-F-2692	EA	2
	8345-00-926-9218	Flag, Signal, "F" Intn'l Code, Size 6 (81349) MIL-F-2692	EA	2

## APPENDIX B

## Section III. BASIC ISSUE ITEMS LIST-CONT

(1) ILLUS NO.	(2) NATIONAL STOCK NUMBER	(3) DESCRIPTION FSCM AND PART NUMBER	(4) USABLE ON CODE U/M	(5) QTY REQ'D
	8345-00-926-9987	Flag, Signal, "G" Intn'l Code, Size 6 (81349) MIL-F-2692	EA	2
	8345-00-935-0448	Flag, Signal, "H" Intn'l Code, Size 6 (81349) MIL7F-2692	EA	2
	8345-00-935-0449	Flag, Signal, "I" Intn'l Code, Size 6 (81349) MIL-F-2692	EA	2
	8345-00-926-6810	Flag, Signal, "J" Intn'l Code, Size 6 (81349) MIL-F-2692	EA	2
	8345-00-926-9988	Flag, Signal, "K" Intn'l Code, Size 6 (81349) MIL-F-2692	EA	2
	8345-00-935-0450	Flag, Signal, "L" Intn'l Code, Size 6 (81349) MIL-F-2692	EA	2
	8345-00-935-0444	Flag, Signal, "M" Intn'l Code, Size 6 (81349) MIL-F-2692	EA	2
	8345-00-926-6001	Flag, Signal, "N" Intn'l Code, Size 6 (81349) MIL-F-2692	EA	2
	8345-00-935-0451	Flag, Signal, "O" Intn'l Code, Size 6 (81349) MIL-F-2692	EA	2
	8345-00-935-0452	Flag, Signal, "P" Intn'l Code, Size 6 (81349) MIL-F-2692	EA	2
	8345-00-935-0453	Flag, Signal, "Q" Intn'l Code, Size 6 (81349) MIL-F-2692	EA	2

## APPENDIX B

## Section III. BASIC ISSUE ITEMS LIST-CONT

(1) ILLUS NO.	(2) NATIONAL STOCK NUMBER	(3) DESCRIPTION FSCM AND PART NUMBER	(4) USABLE ON CODE U/M	(5) QTY REQ'D
	8345-00-926-6812	Flag, Signal, "R" Intrn'l Code, Size 6 (81349) MIL-F-2692	EA	2
	8345-00-935-0454	Flag, Signal, "S" Intrn'l Code, Size 6 (81349) MIL-F-2692	EA	2
	8345-00-926-6002	Flag, Signal, "T" Intrn'l Code, Size 6 (81349) MIL-F-2692	EA	2
	345-00-926-6814	Flag, Signal, "U" Intrn'l Code, Size 6 (81349) MIL-F-2692	EA	2
	8345-00-935-0455	Flag, Signal, "V" Intrn'l Code, Size 6 (81349) MIL-F-2692	EA	2
	8345-00-935-0456	Flag, Signal, "W" Intrn'l Code, Size 6 (81349) MIL-F-2692	EA	2
	8345-00-926-6004	Flag, Signal, "X" Intrn'l Code, Size 6 (81349) MIL-F-2692	EA	2
	8345-00-935-0457	Flag, Signal, "Y" Intrn'l Code, Size 6 (81349) MIL-F-2692	EA	2
	8345-00-935-0458	Flag, Signal, "Z" Intrn'l Code, Size 6 (81349) MIL-F-2692	EA	2
	6230-00-264-8261	Flashlight, Watertight, 2 Cell, Type 1, Style 2 (81349) MIL-F-3747	EA	12
		Flex Socket (15434) 3375300	EA	1



## APPENDIX B

## Section III. BASIC ISSUE ITEMS LIST-CONT

(1) ILLUS NO.	(2) NATIONAL STOCK NUMBER	(3) DESCRIPTION FSCM AND PART NUMBER	(4) USABLE ON CODE U/M	(5) QTY REQ'D
	7330-00-634-1995	Food Turner, Cake, 7-½" Solid Blade (81348) RR-F-575	EA	2
	7340-00-240-7077	Fork, Food Preparation, 14" Long, 2 Tines Steel, Carbon, Type 2, Grade A or B (81348) GGG-C-746	EA	1
	7340-00-223-7791	Fork, Food Preparation, 15" Long, 2 Tines, Stainless Steel (81349) MIL-V-10815	EA	1
	7340-00-241-8169	Fork, Table, Plain Cres, 4 Tines, 24 to Box (81348) RR-F-450	EA	24
	5110-00-289-9657	Frame, Hand, Hacksaw, for 10" to 12" Blade, Type 1, Class 1, Style 1 (81348) GGG-F-671	EA	2
		Fuel Pump Wrench (15434) 3377198	EA	1
	7240-00-404-9793	Funnel, Plastic 1 qt (81348) L-F-1593	EA	1
	7240-00-223-4402	Funnel, Steel w/Strainer, 1 gal (81348) RR-F-800	EA	2
	7240-00-527-9868	Funnel, Steel w/Strainer, 1 qt, Type 1 (81348) RR-F-800	EA	2
	3415-00-517-7754	Grinder, Bench, Utility, Electric, Type 1, Size 7, 115V ac, ½ hp (81349) MIL-G-80260	EA	1
		Guide Spindle (59618) 230P4	EA	1
	4930-00-287-5419	Gun, Fluid, Direct Delivery, 25.8 oz (81348) GGG-0-591	EA	2

## APPENDIX B

## Section III. BASIC ISSUE ITEMS LIST-CONT

(1) ILLUS NO.	(2) NATIONAL STOCK NUMBER	(3) DESCRIPTION FSCM AND PART NUMBER	(4) USABLE ON CODE U/M	(5) QTY REQ'D
	5120-00-892-5485	Hammer, Hand 1 lb, Type 1 (81348) GGG-H-86	EA	1
	5120-00-203-4656	Hammer, Hand, Double Face, 2-½ lb (81348) GGG-H-86	EA	2
	5120-00-061-8546	Hammer, Hand Machinist 32 oz (81348) GGG-H-86	EA	4
	5120-00-224-4111	Hammer, Hand, Scaling, Broiler Pick, 1 lb, Type 6 (81348) GGG-H-86	EA	4
	5120-00-255-1476	Hammer, Hand, Ship's Maul, 5 lb, Type 12 (81348) GGG-H-86	EA	2
	5120-00-243-2957	Hammer, Hand, Sledge, Blacksmith 10 lb, Type 10, Class 1, Double Faced (81348) GGG-H-86	EA	1
	5130-00-190-6442	Hammer, Pneumatic, Portable, Scaling, Type 1, Style A (81348) OO-H-116	EA	2
	5110-00-228-3161	Hatchet, Half (81348) GGG-H-131	EA	1
		Hex Wrench (59618) 237P4	EA	1
	3950-00-235-4235	Hoist, Chain, Hand-Operated, Hook SPNSN, 3/4 Ton (81349) MIL-H-904	EA	2
	3950-00-235-4236	Hoist, Chain, Hand-Operated, Hook SPNSN, ½ Ton (81349) MIL-H-904	EA	2
	3950-00-965-0096	Hoist, Chain, Hand-Operated, Hook SPNSN, 2 Ton (81349) MIL-H-904	EA	1

## APPENDIX B

## Section III. BASIC ISSUE ITEMS LIST-CONT

(1) ILLUS NO.	(2) NATIONAL STOCK NUMBER	(3) DESCRIPTION FSCM AND PART NUMBER	(4) USABLE ON CODE U/M	(5) QTY REQ'D
	3950-00-937-7978	Hoist, Lever and Ratchet, 1000 lb Cap, Type U, Style 1 (06500) P-15S *	EA	2
	3940-00-150-7108	Hoist, Wire Rope; Hand ¾ Ton, 10 ft (93601) 3000-30M	EA	2
	2040-00-268-9250	Hook, Boat 10' (21530) H389	EA	2
	4720-00-202-6482	Hose Assy, Nonmetallic, Water, Rubber Wrapped, ¾" (81348) ZZ-H-601	EA	2,
	5120-01-116-7604	Injector Puller (15434) 3376000	EA	1
	5120-01-262-7308	Injector Puller (15434) 3822482	EA	1
	6225-01-141-3558	Insulation Tester (15434)	EA	1
	No NSN	Kit Cleaning (62144) 06C-0VM500-000	EA	1
	5120-01-146-7131	Kit Driver Bushing (15434) 3376633	EA	1
	6545-00-922-1200	Kit, First Aid, 12 Unit (89875) SC-C-6545-1L	EA	2
	6545-00-168-6893	Kit, First Aid, Life Raft (No Ref)	EA	2
	4730-00-470-6625	Kit, Fitting, Copper Tubing (30327) 51025	EA	2
	4910-00-548-7984	Kit Injector Adjustable (15434) 3375842	EA	1
	No NSN	Kit Injector Adjustable (15434) 3822575	EA	1

## APPENDIX B

## Section III. BASIC ISSUE ITEMS LIST-CONT

(1) ILLUS NO.	(2) NATIONAL STOCK NUMBER	(3) DESCRIPTION FSCM AND PART NUMBER	(4) USABLE ON CODE U/M	(5) QTY REQ'D
	No NSN	Kit, Welding Access, C/D Electrodecable Min. 35 ft Long: 1 ea, Ground Cable w/Clamps, Min. 30' ft Long: 1 ea, Welding Helmet (40608) 040 052	KT	1
	7340-00-223-7769	Knife, Pairing, 3-½" Ht-Carbon Blade Rosewood Handle (81348) CGGC-C-746	EA	2
	7340-00-243-7766	Knife, Slicing, 12" Carbon Steel, Rosewood Handle (81348) CCC-C-746	EA	2
	7340-00-291-0625	Knife, Steak, Food Prep, 10" Long (81348) GGGC-C-746	EA	1
	7340-00-060-6057	Knife, Steak, Table (81348) GGG-C-450	EA	24
	7340-00-241-8170	Knife, Table, Cres (81348) GCCCG-C-450	EA	24
	7330-00-254-4793	Ladle, Kitchen, 2 oz Stainless Steel, w/o Pouring Lip (81348) RR-L-30	EA	1
	7330-00-248-1153	Ladle, Kitchen, 8 oz Stainless Steel, w/o Pouring Lip (81348) RR-L-30	EA	1
	6230-00-783-6519	Lantern, Battle, (Body Assy) w/o Relay (81349) MIL-F-16377/53	EA	5
	6230-00-968-7831	Lantern, Battle, (Bracket Assy) (81349) MIL-F-16377/53	EA	5
	6230-00-776-5920	Lantern, Battle, (Handle and Switch) (81349) MIL-F-16377/53	EA	5
	4940-01-378-3354	Leak Detector, Refrigerant Gas (16734) TIF5650	EA	1

## APPENDIX B

## Section III. BASIC ISSUE ITEMS LIST-CONT

(1) ILLUS NO.	(2) NATIONAL STOCK NUMBER	(3) DESCRIPTION FSCM AND PART NUMBER	(4) USABLE ON CODE U/M	(5) QTY REQ'D
	3940-01-183-9412	Lifting, Sling (15434) 3375957	EA	1
	6230-00-268-9246	Light, Extension, Explosion Proof (81349) MIL-L-4020	EA	2
	1095-00-270-6019	Line Throwing Device (85097) CG 7094	EA	1
	6530-00-042-8131	Litter, Rigid, Stokes (89875)207485	EA	1
	4930-00-253-2478	Lubricating Gun, Hand, 14 oz (81349) MIL-G-3859	EA	2
	5120-01-171-3893	Main Bearing Cap Puller (15434) ST-1116	EA	1
	5120-01-141-5777	Main Bearing Cap Puller (15434) ST-1178	EA	1
	1005-01-228-5142	Mark 26 Mod 15.50 Cal M2HB Machine Gun "Soft Mount" w/Gun Modification Kit	EA	2
	1370-01-074-0591	Marker, Location, Marine, MK58, MOD 1 (10001)3139741	EA	2
	6850-00-270-9986	Marker Sea, Fluorescent (81349) MIL-S-17980	EA	4
	5120-00-221-2731	Marlinespline, 8", Wire Rope Type, w/Eye, Type 1 (81349) MIL-M-15926	EA	1
	7330-00-205-3093	Masher, Potato, Hand (81348) RR-W-456	EA	4
	7240-00-223-6025	Measure, Liquid, 1 gal, Type 1, Class B (81348) RR-M-1850	EA	1
	7330-00-272-7876	Measuring Set, 4 Spoon (81349) MIL-M-40122	EA	1
	8465-00-238-3344	Megaphone, Hand, 18" (81349) MIL-M-1263	EA	1

## APPENDIX B

## Section III. BASIC ISSUE ITEMS LIST-CONT

(1) ILLUS NO.	(2) NATIONAL STOCK NUMBER	(3) DESCRIPTION FSCM AND PART NUMBER	USABLE ON CODE	(4) U/M	(5) QTY REQ'D
	6625-01-139-2512	Multimeter, .AN/PSM-45 (55026) 467		EA	2
		Nanometer (32862) 1050384		EA	1
	4930-00-262-8868	Oiler, Hand, Flex Spout, 1 pt (81348) CCG-O-591		EA	1
	930-00-266-9182	Oiler, Hand, 8 oz (81348) GGG-O-591		EA	1
	5120-01-160-8863	Oil Filter Wrench (g.) (15434) 3375049		EA	1
	5120-01-262-7306	Oil Filter Wrench (sm) (15434) 3376807		EA	1
		Opener, Can Electric (81390) Model 201		EA	1
	7330-00-205-3151	Opener, Can, Manual, Table Mounted, Type 3, Grade A (81348) FF-O-601		EA	2
	5340-00-582-2742	Padlock, Keyed (81348) FF-P-101		EA	1
	7240-00-160-0455	Pail, Utility, Metal, Heavy Weight, 3-½ gal (81348) RR-P-35		EA	3
	7330-00-205-3164	Pan, Baking and Roasting, 13-¼" x 9-¼" x 2-¼" (81348) RR-P-54		EA	1
	7330-00-634-4494	Pan, Baking and Roasting, 24" x 18" x 4-½" (81348) RR-P-54		EA	5
	7330-00-255-5995	Pan, Bread, Four-Pan Set (81348) RR-P-58		SE	1

## APPENDIX B

## Section III. BASIC ISSUE ITEMS LIST-CONT

(1) ILLUS NO.	(2) NATIONAL STOCK NUMBER	(3) DESCRIPTION FSCM AND PART NUMBER	(4) USABLE ON CODE U/M	(5) QTY REQ'D
	7330-00-205-3150	Pan, Cake, Round, 9" dia x 1-½" Deep (81348) RR-P-62	EA	2
	7330-00-238-3805	Pan, Frying, 12" dia (81348) RR-P-89	EA	2
	7330-00-246-2402	Pan, Frying, 6" dia (81348) RR-P-89	EA	12
	7330-00-244-4549	Pan, Muffin, 12 cups, Aluminum, Heavy Duty, Style A (81348) RR-P-54	EA	2
	7330-00-823-6883	Pan, Pie, Aluminum, 9", Style A (81348) RR-P-54	EA	2
	6665-00-050-8529	Paper, Chemical Agent Determination (81361) D5-67-266	BX	1
	7330-00-238-8316	Peeler, Potato, Hand (81349) MIL-P-20583	EA	2
	8345-00-935-0410	Pennant, Signal, Answer Intn'l Code, Size 6 (81349) MIL-F-2692	EA	1
	8345-00-926-5990	Pennant, Signal, Answer 1 <sup>st</sup> Repeater Intn'l Code, Size 6 (81349) MIL-F-2692	EA	1
	8345-00-934-0421	Pennant, Signal, Answer 2 <sup>nd</sup> Repeater Intn'l Code, Size 6 (81349) MIL-F-2692	EA	6
	8345-00-926-9207	Pennant, Signal, Answer 3 <sup>d</sup> Repeater Intn'l Code, Size 6 (81349) MIL-F-2692	EA	2
	8345-00-935-0495	Pennant, Signal, "0" Numeric Intn'l Code, Size 6 (81349) MIL-F-2692	EA	2

## APPENDIX B

## Section III. BASIC ISSUE ITEMS LIST-CONT

(1) ILLUS NO.	(2) NATIONAL STOCK NUMBER	(3) DESCRIPTION FSCM AND PART NUMBER	(4) USABLE ON CODE U/M	(5) QTY REQ'D
	8345-00-935-0401	Pennant, Signal, "1" Numeric Intn'l Code, Size 6 (81349) MIL-F-2692	EA	2
	8345-00-926-6023	Pennant, Signal, "2" Numeric Intn'l Code, Size 6 (81349) MIL-F-2692	EA	2
	8345-00-935-0490	Pennant, Signal, "3" Numeric Intn'l Code, Size 6 (81349) MIL-F-2692	EA	2
	8345-00-935-0491	Pennant, Signal, "4" Numeric Intn'l Code, Size 6 (81349) MIL-F-2692	EA	2
	8345-00-935-0492	Pennant, Signal, "5" Numeric Intn'l Code, Size 6 (81349) MIL-F-2692	EA	2
	8345-00-935-0493	Pennant, Signal, "6" Numeric Intn'l Code, Size 6 (81349) MIL-F-2692	EA	2
	8345-00-926-9214	Pennant, Signal, "7" Numeric Intn'l Code, Size 6 (81349) MIL-F-2692	EA	2
	8345-00-935-0494	Pennant, Signal, "8", Numeric Intn'l Code, Size 6 (81349) MIL-F-2692	EA	2
	8345-00-935-0405	Pennant, Signal, "9" Numeric Intn'l Code, Size 6 (81349) MIL-F-2692	EA	2
	7210-00-205-3205	Pillow, Bed, Type 1, Size 3 (81348) V-P-356	EA	15
	7210-00-292-2326	Pillowcase, Bed (81348) DDD-P-351	EA	30



## APPENDIX B

## Section III. BASIC ISSUE ITEMS LIST-CONT

(1) ILLUS NO.	(2) NATIONAL STOCK NUMBER	(3) DESCRIPTION FSCM AND PART NUMBER	(4) USABLE ON CODE U/M	(5) QTY REQ'D
	5120-01-262-7316	Piston Ring Compressor (15434)3822736	EA	1
	5120-01-262-7315	Piston Ring Compressor (15434)3375342	EA	1
	5120-00-116-7676	Piston Ring Compressor (15434) ST-755	EA	1
	5120-00-150-7486	Piston Ring Expander (15434) ST-763	EA	1
	7350-00-195-4763	Pitcher, Syrup, Glass 14 oz Body Chrome Top (81348) DD-T-101	EA	6
	7350-00-249-5165	Pitcher, Water, 2 qt Stainless Steel, Style A, Size 2 (81348) RR-P-386	EA	2
	5110-00-239-8253	Pliers, Diagonal Cutting, Plain, Regular Nose, 6" Long, Type 1, Class 1 (81348) GGG-P-458	EA	2
	5120-00-248-9420	Pliers, Lineman's, w/Side Cutters and Wire Skinners, 8" Long, Type 2, Class 2 (81348) GGG-P-00471	EA	2
	5120-00-239-8251	Pliers, Lineman's, w/Side Cutters 8" Long, Plain Handle, Type 2, Class I Style A (81348) GG-P-471	EA	2
	5120-00-223-7326	Pliers, Slip Joint, Straight Nose, 6" Long, Type 2, Class 2, Style A (81348) GGG-P-471	EA	1

## APPENDIX B

## Section III. BASIC ISSUE ITEMS LIST-CONT

(1) ILLUS NO.	(2) NATIONAL STOCK NUMBER	(3) DESCRIPTION FSCM AND PART NUMBER	(4) USABLE ON CODE U/M	(5) QTY REQ'D
	7910-00-224-7985	Polisher, Floor (Buffer 10.5 Dia)	EA	1
	7910-00-680-8296	Polisher, Floor (Buffer 14.5 Dia)	EA	1
	7330-00-775-3941	Pot, Cooking, w/Cover 9 qt (81349) MIL-P-49636	EA	1
	6685-01-107-6875	Pressure Manometer (23582) PVS-2	EA	1
	4240-00-022-2946	Protector, Aural, Sound (81349) MIL-P-38268	EA	12
	6675-00-191-1514	Protractor, Plastic 3 Arm, Type 2 (81349) MIL-P-288	EA	1
	5120-00-224-9453	Puller, Fuse, ¼" and ½" Dia, (81348) W-P-796	EA	1
	5120-00-224-9456	Puller, Fuse, ½" and 1-¼" Dia, Type 1, Size 3 (81348) W-P-796	EA	1
	5120-00-243-2776	Puller, Fuse, 1" and 2-½" Dia, Type 1, Size 3 (81348) W-P-796	EA	2
	5120-00-595-9304	Puller, Mechanical, Double End Grip, Two Jaw, External, 6" Spread, 3" Reach, Type 1, Class 1, Style B (81348) GGG-P-781	EA	1
	5120-00-288-7710	Puller, Mechanical, Gear and Bearing, 0" to 7" Spread, 5-1/8" Reach, Type 1, Class 1 (81348) GGG-P-781	EA	2

☆ U.S. GOVERNMENT PRINTING OFFICE: 1993 0-342-421 (80326)

## APPENDIX B

## Section III. BASIC ISSUE ITEMS LIST-CONT

(1) ILLUS NO.	(2) NATIONAL STOCK NUMBER	(3) DESCRIPTION FSCM AND PART NUMBER	(4) USABLE ON CODE U/M	(5) QTY REQ'D
	5120-00-499-1489	Puller Stand (15434) ST-647	EA	2
	No NSN	Pump Oil Evacuation (32862) 1009004	EA	1
	4320-00-437-0046	Pump Unit, Centrifugal, Elec Submersible' (39428) 4327K4	EA	2
	4320-01-186-3377	Pump, Centrifugal, P250 Mod 1 (26840) 545-2150-00-0 Pump, P250 Accessory (26840) 340-0530-00-0	EA EA	1 1
	4930-00-263-9886	Pump, Dispensing, Hand Rotary, Type 1, Class 1 (81349) MIL-D-40078	EA	1
	4310-00-289-5967	Pump, Vacuum (To Pull Vacuum on Air Conditioning and Refrigeration Systems) No Ref	EA	1
	5110-00-499-7313	Punch Set, Cutting, Double Bow, 7 Hollow Punches, Sizes ¼" to 5/8" Dia (45225) HP 7	SE	1
	5120-00-223-1016	Punch, Drive, Pin ¼" Type 8, Class B (81348) CCG-P-831	EA	2
	5120-00-223-1014	Punch, Drive, Pin 1/8" Type 8, Class B (81348) GGG-P-831	EA	1
	5120-00-223-1018	Punch, Drive, Pin 3/8" Type 8, Class B (81348) CG-P-831	EA	1

## APPENDIX B

## Section III. BASIC ISSUE ITEMS LIST-CONT

(1) ILLUS NO.	(2) NATIONAL STOCK NUMBER	(3) DESCRIPTION FSCM AND PART NUMBER	USABLE ON CODE	(4) U/M	(5) QTY REQ'D
	4130-01-338-2707	Recovery/Recycling Machine, Freon		EA	1
	4240-00-629-8199	Respirator, Air Filtering (81348) GGG-M-125/8		EA	1
	5120-00-017-2849	Riveter, Blind, Hand (81348) GGG-R-00395		EA	1
		Rocker Level Actuator (15434) 3375539		EA	1
	4020-00-752-8879	Rope, Nylon, Mooring, 4" Dia., 41, 300 lbs Breaking strength (81349) MIL-R-17343		EA	1
	4020-00-542-3308	Rope, Nylon, Mooring, 6" Dia., (81349) MIL-R-17343		EA	1
	6675-00-191-1509	Rule, Parallel, 18" Navigators, Folding (81348) GG-P-118		EA	1
	7510-00-161-6215	Ruler, Wood, 12" Long (81348) GG-R-791		EA	1
	7510-00-161-6217	Ruler, Wood, 18" Long (81348) GG-R-791		EA	1
	5130-00-226-5387	Sander, Disc, Elec, Portable, 115V ac/dc, Pad 7" Dia., Type II, Style 1, Size 7, Heavy duty, SP Feat Double Insulated (81348) 00-S-001116		EA	3
	7330-00-240-2134	Saucepan, w/Cover, 2 qt., size 1 (81349) MIL-S-40044		EA	3
	7330-00-240-2137	Saucepan, w/Cover, 7-½ qt., size 3 (81349) MIL-S-40044		EA	2
	5110-00-293-3435	Saw, Hand, Crosscut, 26" TYV (81348)		EA	2

## APPENDIX B

## Section III. BASIC ISSUE ITEMS LIST-CONT

(1) ILLUS NO.	(2) NATIONAL STOCK NUMBER	(3) DESCRIPTION FSCM AND PART NUMBER	(4) USABLE ON CODE U/M	(5) QTY REQ'D
	5130-00-965-9876	Scaling and Chipping tool, Pneumatic (81349) MIL-S-24392	EA	2
	7330-00-153-9760	Scoop, Kitchen, Stainless Steel, 7-7/8" x 5-1/4" (81349) RR-S-131	EA	1
	5120-00-542-3438	Screwdriver, Cross Tip, No. 2, 8" Long, Type 6, Class 1, Style 1 (81348) GGG-S-121	EA	2
	5120-00-293-3309	Screwdriver, Flat Tip, Plain, Medium Heavy Duty, 3/8" TIP, 10" Long, Type 1, Design A (81348) GGG-S-121	EA	2
	5120-00-278-1282	Screwdriver, Flat Tip, 4" Long, 1/4" NOM TIP Width Long, Type 1, Class 5, Style 1, Design, B, Shape B (81348) GGG-S-121	EA	1
	5120-00-278-1267	Screwdriver, Flat Tip, 8" Long, 9/64" Nom Tip Width, Type 1, Class 1, Design A (81348) GGG-S-121	EA	2
	5120-00-237-6985	Screwdriver, Flat Tip, 8" Long, 1/2" Nom Tip Width, Type 1, Class 5, Design A (81348) GGG-S-121	EA	2
	6605-00-224-7735	Sextant, Marine, Rng of Arc -50 to 145 Deg W/Case and Polaroid Filters, Type A (81349) MIL-S-2387	EA	1
	7350-00-240-7068	Shaker, Pepper, 9 Cu In Cap, Type A (81348) RR-R-260	EA	2

## APPENDIX B

## Section III. BASIC ISSUE ITEMS LIST-CONT

(1) ILLUS NO.	(2) NATIONAL STOCK NUMBER	(3) DESCRIPTION FSCM AND PART NUMBER	(4) USABLE ON CODE U/M	(5) QTY REQ'D
	7350-00-680-2630	Shaker, Salt and Pepper, Glass Body, Stainless Steel top, 2 oz (81348) DD-T-101	EA	2
	7350-00-240-7069	Shaker, Salt, 9 Cu In Cap, Type 0 (81348) RR-R-260	EA	1
	7330-00-798-7356	Sharpener, Knife, Wall Mounted (8134) RR-S-00310	EA	1
	7520-00-162-6178	Sharpener, Pencil, Manual (81348) GG-S-236	EA	1
	5110-00-293-0089	Sheers, Metal Cutting, Str Cut, 2-½" to 3-½" Cut, 12-½" Overall Length, Type 2, Class 1, Style B (81348) GGG-S-291	EA	1
	5110-00-221-1087	Shears, Metal Ctg, Combination Cut, 12-½" Overall Length, 2-¾" to 3-½" Cut, Type 2, Class 3 (81348) GGG-S-291	EA	2
	5110-00-161-6909	Shears, Straight Trimmers, 9", 1 Bevel/i Sharp Pt, Type 1, Class 1, Style A, Design 2 (81348) GGG-S-00278	EA	1
	5110-00-223-6370	Shears, Tailor's, (Sailmakers), 12" Overall Length, Type 1, Class 4 (81348) GGG-S-00278	EA	1
	7210-00-148-1017	Sheet, Bed, 63" x 106", Type 6, Size 5 (81348) DDD-S-281	EA	60
	7330-00-184-0089	Sifter, Flour 1-½ qt (81348) RR-S-345	EA	1

**APPENDIX B**  
**SECTION III. BASIC ISSUE ITEMS LIST - CONT.**

(1) ILLUS NO.	(2) NATIONAL STOCK NUMBER	(3) DESCRIPTION FSCM AND PART NUMBER	(4) USABLE ON CODE	(5) QTY REQ'D
	1370-00-629-2336	Signal, Illumination, Ground, Red Star, Parachute, M126A1 (19203) 8797968	EA	12
	5850-00-407-6671	Signal, Lamp Equip (80063) SE 11	EA	1
	5120-01-113-8078	Socket Set P/Well 1/2" Drive (55719) 318TVVMY	EA	1
	3439-00-930-1638	Soldering Gun, Electric, Trigger Operated (11103)450	EA	1
	7330-00-684-8740	Spatula, Steel, 14" Blade (81348) GGG-C-746	EA	1
	7340-00-223-7800	Spoon, Basting 21" Long (81349) MIL-U-10815	EA	2
	7340-00-241-8171	Spoon, Dessert 7" Long (81348) RR-F-450	EA	2
	7340-00-240-7080	Spoon, Food Service, 15" Long, Type 1 (81348) R-S-617	EA	2
	7340-00-205-3340	Spoon, Iced Tea 6" Long (81348)RR-F-460	EA	24
	7340-00-205-1421	Spoon, Slotted Serving, 15" Long, Type 2 (81348) RR-S-617	EA	2
	7340-00-205-3341	Spoon, Table, Cres (81348)RR-F-450	EA	24
	7240-00-177-6154	Spout, Flexible (81349) MIL'S-1285	EA	2
		Spring Hook (59618)229P4	EA	1
	7520-00-298-7044	Stencil Set, Marking 2" Brass Interlocking Letters (81348) RR-S-714	SE	1

**APPENDIX B  
SECTION III. BASIC ISSUE ITEMS LIST - CONT.**

(1) ILLUS NO.	(2) NATIONAL STOCK NUMBER	(3) DESCRIPTION FSCM AND PART NUMBER	(4) USABLE ON CODE U/M	(5) QTY REQ'D
	7520-00-272-9683	Stencil Set, Marking 3" Brass Interlocking Letters (81348) RR-S-714	SE	2
	7S20-00-298-7043	Stencil Set, Marking 1" Brass Interlocking Letters (81348) RR-S-714	SE	1
	7110-00-634-8596	Stool, Revolving, Metal, Gray, Type 2, Size 1 (81348) AA-S-7	EA	1
	6645-00-250-4680	Stopwatch, 60 Second D-al, Type 1, Class 2 (81348) GG-S-764	EA	1
	6680-00-351-9702	Tachometer, Mechanical Hand Held Mech, Oper Rng (57737) 1412	EA	2
-	5210-00-526-0752	Tape, Measuring, Tank Level Gage, 50' Long, Brass Plumb Bob, Glare Free (37163) 14075	EA	2
	6630-00-074-0394	Test Kit, Chromate (71881) 121	EA	1
	6630-00-531-1968	Test Kit, Oil Condition (81349) MIL-T-19467	EA	1
	6630-00-171-5126	Tester, Battery, Electolite Soln, Specific Gravity Range 1.1 To 1.35, Class 1, Style B (81348) GG-T-258	EA	1
	6685-00-255-9981	Thermometer, Self-Indicating, Liquid In Glass, 200 To 600 DEG F (81348) GG-T-315	EA	1



**APPENDIX B  
SECTION III. BASIC ISSUE ITEMS LIST - CONT**

(1) ILLUS NO.	(2) NATIONAL STOCK NUMBER	(3) DESCRIPTION FSCM AND PART NUMBER	(4) USABLE ON CODE U/M	(5) QTY REQ'D
	6685-00-641-0189	Thermometer, Self-Indicating, Meat 140 To 200 DEG F. Type 1 (81348) GG-T-353	EA	2
	4910-01-097-6948	Thermostat Seal Mandrel (15434) ST-1225	EA	1
	5120-01-262-7304	Thermostat Seal Mandrel (15434) ST-1226	EA	1
	5120-01-263-0138	Thermostat Seal Mandrel (15434) 3375411	EA	1
	5180-00-313-3042	Threading Set, Pipe 1/8" TO 1" Holding Cap, 32" To 44" Die (26232) R29A	SE	1
	5180-00-357-7514	Threading Set, Pipe 1/8" TO 1", Type 1, Class 1 (81348) GG-T-581	KT	2
	5180-00-448-2362	Threading Set, Screw, 1/4" - 2 TO 1"-8 NC, Type 1 (81348) GGG-T-330	KT	1
	5180-00-422-4975	Threading Set, Screw, W/Case RH Thread,, 26 PC, Sizes 1/4"-28 To 1"-12 NF, Type 1 (81348) GGG-T-330	KT	1
		Timing Block (15434) 3377259	EA	1
		Toaster, Electric, Auto (78770) TP 120	EA	1
	7330-00-616-0997	Tongs, Food Serving, 12" Long (81349) MIL-T-40097	EA	1
	5180-00-293-2815	Tool Kit, Carpenter (81336) ENG6350-010	KT	1

**APPENDIX B**  
**SECTION III. BASIC ISSUE ITEMS LIST - CONT**

(1) ILLUS NO.	(2) NATIONAL STOCK NUMBER	(3) DESCRIPTION FSCM AND PART NUMBER	(4) USABLE ON CODE U/M	(5) QTY REQ'D
	5180-00-391-1087	Tool Kit, Electrical Repair (80064) 9000S6202-73125R	KT	1
	5180-00-629-9783	Tool Kit, General Mechanics, Rail And Marine (81996) SM 55-4-5180S02	KT	2
	5120-00-691-1165	Tool Kit, Hydraulic Hose (00624) 5168	EA	1
	5820-00-511-1950	Tool Kit, Machinist (19204) SC5280-95-CL	SE	1
		Tool Kit, Oil Injection (68225) 201294	EA	1
	5180-00-596-1474	Tool Kit, Service Refrigeration (50980) SC 5180-00-97-CL	KT	1
	5180-00-754-0661	Tool Kit, Welder (81996) SC5180-00-97-CL	KT	1
	5280-00-278-9919	Tool Set, Measuring, Machinist (19024) SC5280-95-CL-A01	SE	1
	5130-00-288-6577	Tool, Scaling And Chipping (81349) MIL-STD-1337	EA	6
	3439-00-542-0531	Torch Kit, Soldering, L. P. Gas (61112) LP-9996	EA	1
	3433-00-357-8116	Torch Outfit, Cutting And Welding, Medium Duty, Oxygen And Acetylene (50980) SC3433-90-CL-N03	EA	1
	NO NSN	Torque Wrench Kit (15434) 3377217	EA	1
	6330-00-127-4774	Total Discolved Solids (TDS) Meter (30053) 532T1	EA	1

**APPENDIX B  
SECTION III. BASIC ISSUE ITEMS LIST - CONT**

(1) ILLUS NO.	(2) NATIONAL STOCK NUMBER	(3) DESCRIPTION CAGEC AND PART NUMBER	(4) USABLE ON CODE	(5) QTY REQ'D
	7350 00 195-7334	Tray, Mess, Cres, 6 Compartment, 1" Deep, 11-5/8" Wide, 15-1/2" Long (81349) MIL-T-46	EA	2
	7350-00-926-6181	Tray, Service (81348) L-T-776	DZ	4
	6675-00-190-5867	Triangle, Drafting-, Plastic, 30 to 60 Degree, 10", Type 1 (81348) GG-T-671/4	EA	2
	6675-00-190-5862	Triangle, Drafting, Plastic, 45 X45 Degree, 8", Type 1 (81348) GG-T-671	EA	2
	7350-00-680-0645	Tumbler, Drinking, Plastic, 8 oz (81348) L-T-800	DZ	1
	7430-00-254-4321	Typewriter, Office, Nonportable (No ref)	EA	1
		Valve Spring Compressor (15434) ST-448	EA	1
	5120-00-221-1117	Vice, Machinist's, Swivel Base, Stationary Jaw, 5" Jaw, 8" Opening, Class 2 (81348) GGG-V-410	EA	2
	5120-00-221-1066	Vice, Pipe, Chain, 1/8" to 2-1/2" Pipe Dia, Type 1, Class 1 (81348) GGG-V-415	EA	1
	7240-00-965-4427	Waste Receptacle, Trash Can with Cover, Polyethylene Plastic, 10 gal (81348) L-W-25	EA	2
	7240-00-857-2277	Waste Receptacle, Trash Can with Cover, Polyethylene Plastic, 24 gal (81348) L-W-25	EA	2
	5120-01-171-3905	Water Tube Driver (15434) ST-1319	EA	1
	6605-00-273-6985	Weight, Sound-Ing, 9 lbs (81349) MIL-S-3717	EA	2
	8465-00-254 8803	Whistle, Plastic, Ball, with Lanyard (81349) MIL-W-1053	EA	29
	5120-01-262-7319	Wrench (3/4") (15434) 3376191	EA	2
	5120-01-262-7320	Wrench (15/16") (15434) 3376192	EA	2
	5120-01-262-7321	Wrench (7/8") (15434) 3376193	EA	2
	5120-00-240-5328	Wrench, Adjustable, 7-1/2" to 8-1/2", Type C, Class A, Size 8 (81348) GGG-E-631	EA	1
-	5130-00-234-4881	Wrench, Impact, Pneumatic, Body Grip Handle, 3/8" Square Drive (81348) OO-W-891	EA	2
	5130-00-184-1427	Wrench, Impact, Pneumatic, Pistol Grip Handle, 3/4" Square Drive (81348) OO-W-891	EA	1

**APPENDIX B  
SECTION III. BASIC ISSUE ITEMS LIST - CONT**

(1) ILLUS NO.	(2) NATIONAL STOCK NUMBER	(3) DESCRIPTION CAGEC AND PART NUMBER	(4) USABLE ON CODE U/I	(5) QTY REQ'D
		Wrench, Lamp	EA	1
	5120-00-499 8083	Wrench, Open End Adjustable, 9-1/2" to 10-1/2" Long, 1-1/8" Jaw Opening, Size 10 (81348) G-W-631	EA	1
	5120-00-264-3796	Wrench, Open End Adjustable, 11-1/2" to 12-1/2" Long, 1-5/16" Jaw Opening, See 12 (81348) G(;G-W-631	EA	2
	5120-00-277-1484	Wrench, Pipe, Adj, Heavy Duty, 8", 3/4" cap, Type 2, Class A, (81348) GGG W-651	EA	2
	5120-00-277-1485	Wrench, Pipe, Adj, Heavy Duty, 10", Type 2, Class A, (81348) GGG W 651	EA	2
	5120-00 277-1486	Wrench, Pipe, Adj, Heavy Duty, 14", Type 2, Class A, (81348) GGG W-651	EA	2
	5120-00-277-1461	Wrench, Pipe, Adj, Heavy Duty, 18", Type 2, Class A, (81348) GGG W 651	EA	2
	5120-00-277-1462	Wrench, Pipe, Adj, Heavy Duty, 24", Type 2, Class A, (81348) GGG W-651	EA	2
	5120-00-270-4309	Wrench, Pipe, Adj, Heavy Duty, 36", Type 2, Class A, (81348) GGG-W-651	EA	2
	5120-00-277-4244	Wrench, Plier, Straight Jaw, 8-1/2", Type 1, Class 1, Style A (81348) GGG-W-649	EA	2
	5120-00-935-7333	Wrench Set, Combination (55719) OEXM709	SE	1
	5120-00-081-2309	Wrench Set, Socket, 1. Square Drive, 12 Point, 1-1/2" to 3-1/8" (81348) GGG W-641	SE	2
	5120-00-204-1999	Wrench Set, Socket, 3/4" Square Drive, 12 Point 7/8" to 2" (81348) GGG-W-641	SE	1
	5120-00-132-0399	Wrench Set, Socket Insert for Converting Standard Socket to Metric Sizes) (90521) VM-820	SE	1
		Wrench, Spanner (77408) 28-8627-8012	EA	1
		Wrench, Spanner, Adjustable (62321) 7492	EA	1
	5120-00-288-6468	Wrench, Spanner, Fixed Pivot, Adjustable Hook 3/4" to 2", Type 1, Class 1, (81348) GGG W-665	EA	1
	7920-00-579-8484	Wringer and Bucket, Mop, Light Duty, 16 qt (81348) RR-M-1075	EA	2

**APPENDIX B**  
**SECTION IV. BASIC ISSUE ITEMS LIST**  
**Firefighting, Safety, and Damage Control Items**

(1) ILLUS NO.	(2) NATIONAL STOCK NUMBER	(3) DESCRIPTION CAGEC PART NUMBER	(4) USABLE ON CODE	(5) QTY REQ'D
	4210-00-209-5023	Adapter, 1-1/2" National Pipe Thread to 1-1/2" National Standard Thread	EA	2
	6840-01-315-9841	Bacteriostatic Additive, (Eye and Face Wash Fountain)	BX	1
	8460-00-606-8366	<b>FIRE FIGHTERS ENSEMBLE</b> Bag, Ore Fighter Ensemble	EA	6
	8430-00-753-5935	Boots, Size 5	PR	6
	8430-00-753-5936	Boots, See 6	PR	6
	8430-00-753-5937	Boots, Size 7	PR	6
	8430 00-753-5938	Boots, Sizes	PR	6
	8430-00-753-5939	Boots, Size 9	PR	6
	8430-00-753-5940	Boots, Size 10	PR	6
	8430-00-753-5941	Boots, Size 11	PR	6
	8430-00-753-5942	Boots, Size 12	PR	6
	8430-00-753-5943	Boots, See 13	PR	6
	8430-00-753-5944	Boots, Size 14	PR	6
	8430-00-753-5945	Boots, See 15	PR	6
	8415-01-300-6557	Coverall, Medium	EA	3
	8415-01-300 6558	Coverall, Large	EA	2
	8415-01-300-6559	Coverall, X-Large	EA	1
	8415-01-267-9661	Gloves, Anti-Flash	PR	6
	8415-01-335-7902	Gloves, Medium	PR	3
	8415-01-335-7903	Gloves, Large	PR	2
	8415-01-335-7904	Gloves, X-Large	PR	1
	8415-01-271-8069	Helmet	EA	6
	8415-01-268-3473	Hood, Anti-Flash	EA	6
	4220-00-276-8926	Buoyant Vest, Work Type	EA	6
	NA	Bum Dressing Kit, Contains two 8" X 18", one 4" X 16", four 4" X 4", one 12" X 16- (Face Mask) Dresses, and one Package of Bum-Jel Topical Dressing, (No NSN, Local Purchase Item) Ordering Informa- tion -Water-Jel AWK Kit", H 8 H Associates Inc. P O Box 4469, Alexan- dna, VA 22303, Phone 1-800-326-5708	EA	1
	4240-00-238-9959	Canister, Training	EA	2
	4240-01-159-1986	Canister, Training, Locker	EA	1

**APPENDIX B  
SECTION IV. BASIC ISSUE ITEMS LIST  
Firefighting, Safety, and Damage Control Items - CONT**

(1) ILLUS NO.	(2) NATIONAL STOCK NUMBER	(3) DESCRIPTION CAGEC PART NUMBER	(4) USABLE ON CODE	(5) QTY REQ'D
	2720-227-7225	Duct, 8. Dia X 15' Long, With Carrier	EA	2
	4240-01-116-9888	Emergency Escape Breathing Device (EEBD)	EA	22
	NA	Emergency Position Radio Beacon (EPIRB), Category 1, 406 MHz Satellite, FC C Approved (No NSN, Local Purchase Item)	EA	1
	4240-00-542-2048	Face Shield, Industrial, Tilting	EA	3
	4210-00-142-4949	Fire Ax	EA	6
	NA	Fire Blanket, 72" X 60., (No NSN, Local Purchase Item) Ordering Information -Water-Jel AWK Fire Blanket , H & H Associates Inc., P O Box 4469, Alexandria, VA22303, Phone 1-800-326-5708	EA	1
	4210-00-889-2491	Fire Extinguisher, Portable, 10 lb, USCG Approved	EA	19
	4820-00-540-2381	Foot Valve with Strainer, 3 - ID	EA	1
	4240-01-258-1245	Fountain, Eye and Face Wash, 16 Gal	EA	1
	4240-00-190-6432	Goggle, Industrial, No Vents, (Chemical Flash)	EA	1
	4240-00-052-3776	Goggle, Safety, Vented, Clear	EA	15
	8415-00-935-3136	Hardhat, Orange	EA	10
	8415-00-935 3139	Hardhat, White	EA	5
	4240-00-022-2522	Harness, Safety, Torso	EA	6
	4240-00-540-0632	Helmet, Welder's	EA	1
	2040-00-268-9250	Hook, Boat	EA	2
	4210-00-776-0657	Hose, Exhaust, Engine, 2" ID X 20 ' Long	EA	1
	4210-01-131-0249	Hose, Fire, 1 1/2" X 50 ', Orange	EA	10
	4210-01-131-0247	Hose, Fire, 2 1/2" X 50', Orange	EA	4
	4210-01-248-8822	Hose, Potable Water, 1 1/2" X 50', Blue	EA	3
	4210-00-725-9234	Hose, Exhaust, Suction, 3/4" ID X 10 ' Long	EA	1
	NA	Hydrostatic Release Unit, HammarH20, Liferaft (No NSN, Local Purchase Item), Hammar H20, MPN 6D887, Part Number HA2000H	EA	2
	8415-00-268-8264	Jacket, Welder's	EA	1
	6545-01-155-1598	Kit, Flotation Assembly, Includes two Flotation Tubes with Covers, five Restraint Straps, and one five pound Ballast Bar	KT	1

**APPENDIX B  
SECTION IV. BASIC ISSUE ITEMS LIST  
Firefighting, Safety, and Damage Control Items - CONT**

(1) ILLUS NO.	(2) NATIONAL STOCK NUMBER	(3) DESCRIPTION CAGEC AND PART NUMBER	(4) USABLE ON CODE	(5) QTY RQR
	4730-00-542-3359	Kit, Pipe Repair, Emergency, P/N MIL-17882B (81349)	KT	1
	4240-00-022-2518	Lanyard, Safety Harness	EA	6
	4240-00-022-2521	Lanyard, Safety Harness, Dyna Brake	EA	4
	4010-00-285-9901	Life Line, OBA Tending	EA	2
	5510-00-260-8953	Plug, Soft Wood, 1 " x o" x 3" Long	EA	10
	5510-00-260-8958	Plug, Soft Wood, 2" X 0" X 4" Long	EA	10
	5510-00-260-8962	Plug, Soft Wood, 3" X on X 8" Long	EA	10
	5510-W-260-8969	Plug, Soft Wood, 7" x 3" X 1 0" Long	EA	10
	5510-00-260-8973	Plug, Soft Wood, 8" X 4" X 1 0" Long	EA	5
	5510-00-260-8949	Plug, Soft Wood, 10" X 7" x 12" Long	EA	5
	4220-00-275-3157	Ring Buoy, Life Saving, 30"	EA	8
	2090-00-052-1581	Shoring, Steel, Adjustable, Long, 6' to 11'	EA	5
	2090-00-058-3737	Shoring Steel, Adjustable, Short, 3' to 5'	EA	5
	1670-01-226-5300	Sling, Rescue Helicopter Hoisting	EA	1
	9390-01-078-8660	Tape, Retro Reflective, 3" X 50 yds	RL	1
	9390-01-082-8927	Tape, Retro Reflective, 1" X 50 yds	RL	1
	4240-01-116-9889	Training Unit, EEED	EA	1
	5510-00-268-3479	Wedge, Plug, Tapered, Hardwood, 2" X 2" X 8" Long	EA	10
	5510-00-268-3485	Wedge, Plug, Tapered, Hardwood, 4" X 2" X 8" Long	EA	10
	5510-00-268-3481	Wedge, Plug, Tapered, Hardwood, 3" X 3" X 12" Long	EA	10
	5510-00-268-3475	Wedge, Shoring Tapered, Hardwood, 1 1/2"X2"X12"Long	EA	10
	5510-00-268-3476	Wedge, Shoring, Tapered, Hardwood, 1 1/2" X 3" X 12" Long	EA	10
	5120-00-277-9075	Wrench, Spanner, Adj 1 1/2" to 3"	EA	10
	5120-00-277-9076	Wrench, Spanner, (P-250 Pump)	EA	10

## APPENDIX C

## ADDITIONAL AUTHORIZATION LIST

## Section I. INTRODUCTION

C-1. **Scope.** This appendix lists additional items you are authorized for the support of the Landing Craft, Utility (LCU)

C-2. **General.** This list identifies items that do not have to accompany the LOU and that do not have to be turned in with it. These items are all authorized to you by CTA, MTOE, TDA, or JTA.

C-3. **Explanation of Listing.** National Stock Numbers, descriptions, and quantities are provided to help you identify and request the additional items you require to support this equipment. The items are listed in alphabetical sequence by item name under the type document (i.e., CTA, MTOE, TDA, or JTA) which authorizes the item(s) to you.



APPENDIX C

Section II. ADDITIONAL AUTHORIZATION LIST

(1) NATIONAL STOCK NUMBER	(2) DESCRIPTION FSCM AND PART NUMBER USABLE ON CODE	(3) U/M	(1) QTY AUTH
COLD WATER EMERSION SUITS			
4220-01-251-6467	JUMBO (63806) ISS-590 JUMBO	DQV EA	A/R
4220-01-251-9231	SMALL (63806) ISS-590 SMALL	DQV EA	A/R

**APPENDIX D****EXPENDABLE/DURABLE SUPPLIES AND MATERIALS LIST****Section I. INTRODUCTION**

D-1. **Scope.** This appendix lists expendable/durable supplies and materials you will need to operate and maintain the Landing Craft, Utility (LCU). This listing is for Informational purposes only and is not authority to requisition the listed items. These items are authorized to you by CTA 50-970, Expendable/Durable Items (Except Medical, Class V, Repair Parts, and Heraldic Items), or CTA 8-100, Army Medical Department Expendable/Durable Items.

**D-2. Explanation of Columns**

a. Column (1) - Item Number This number is assigned to the entry in the listing and is referenced in the narrative instructions to identify the material (e g , "Use the cleaning compound, item 5, App D")

b. Column (2) - Level This column identifies the lowest level of maintenance that requires the listed item

- C - Operator/Crew
- O -Organizational Maintenance
- F - Direct Support Maintenance
- H - General Support Maintenance

c. Column (3) - National Stock Number. This is the National Stock Number assigned to the item, use it to request or requisition the item.

d. Column (4) - Description Indicates the Federal Item Name and, if required, a description to identify the item. The last line for each item indicates the Federal Supply Code for Manufacturer (FSCM) in parentheses followed by the part number.

e. Column (5) - Unit of Measure (U/M) Indicates the measure used in performing the actual maintenance function. This measure is expressed by a two-character alphabetical abbreviation (e g , ea. in, pr). If the unit of measure differs from the unit of issue, requisition the lowest unit of issue that will satisfy your requirements.

**APPENDIX D**  
**SECTION II. EXPENDABLE / DURABLE SUPPLIES AND MATERIAL LIST**

(1) ITEM NO.	(2) LEVEL	(3) NATIONAL STOCK NUMBER	(4) DESCRIPTION	(5) U/M
1		6850-00-181-7933	Antifreeze, Ethylene Glycol, Inhibited Heavy Duty 5 gal Can (81349) MIL-A-46153	GL
2		6135-00-120-1020	Battery, Flashlight 1.5V, 1 Term (81349) BA-30	EA
3		7510-00-889-3494	Binder, Looseleaf, Equipment Log Book, 3 Ring, Size 2 (81349) MIL-B-43064	EA
4		5110-00-277-4591	Blades, Hand, Hacksaw High-Speed Steel, 12" la, 24 Teeth per Inch (81348) GGG-B-451	EA
5		7920-00-267-2967	Broom, Push, Rattan (no handle) (81348) H-B-71	EA
6		7920-00-291-8305	Broom, Upright, Corn, Type 2 (81348) H-B-0051	EA
7		7920-00-240-6358	Broom, Dusting, Bakery, Bench, Type 1, Class 2, Style 1 (81348) H-B-190	EA
8		7920-00-165-7277	Brush, Dusting' Bench Natural Lacquered Block Handle, for Coarse Brushing (85092) 378	EA
9		7920-00-243-3407	Brush, Floor Sweeping, 18" (no handle) (81348) H-B-651	EA
10		7920-00-772-5800	Brush, Sanitary, Type 1, Class 2, Duty A (81348) H-B-00481	EA
11		7920-00-240-7171	Brush, Scrub, Deck (no handle) 2-3/4" x 9-3/4", Type 1 (81348) H-B-531	EA
12		7920-00-240-7174	Brush, Scrub, Floor, Hand 2-3/4" x 6", Palmetto Fiber (81348) H-B-1490-5	EA

**APPENDIX D**  
**SECTION II. EXPENDABLE / DURABLE SUPPLIES AND MATERIAL LIST - CONT**

(1) ITEM NO.	(2) LEVEL	(3) NATIONAL STOCK NUMBER	(4) DESCRIPTION	(5) U/M
	13	7920-00-246-8501	Brush, Wire, Scratch 7-1/2" X 2-1/4", Type 4, Class 1 (81348) U-B-178	EA
	14	7920-00-291-5815	Brush, Wire, Curved Handle, Type 2, Class 1 (81348) H-B-178	EA
	15	5130-00-293-026	Brush, Wire, Rotary Wheel, 1/2" Arbor, 6", Type 3, Class 1, Style (81348) H-B-771	EA
	16	6850-00-110-4498	Cleaning Solvent	CN
	17	5999-00-195-9689	Clip, Electrical, Crocodile, 3-1/2" LO (81348) W-C-440	EA
	18	7520-00-240-5503	Clipboard, File, 9" x 17" (81348) LLL-A-00650	EA
	19	7930-00-880-4454	Compound, Dishwashing, Hand, Liquid (81348) P-D-410	EA
	20	8030-00-616-7694	Compound, Antiseize (Pipe Joint and Thread) (81349) MIL-T-83483	LB
	21	8030-00-231-2345	Compound, Corrosion Preventative (81349) MIL-C-16731	GL
	22	4020-00-240-2164	Cord, Cotton, 1/4" (81348) MIL-L-1145	CL
	23	4020-00-240-2160	Cord, Cotton, 5/16" (81348) T-C-571	CL
	24	6850-00-753-4967	Corrosion Preventative	GL
	25	9140-00-286-5294	Diesel Fuel #2	BL

**APPENDIX D**  
**SECTION II. EXPENDABLE / DURABLE SUPPLIES AND MATERIAL LIST**

(1) ITEM NO.	(2) LEVEL	(3) NATIONAL STOCK NUMBER	(4) DESCRIPTION	(5) U/M
26		5345-00-881-8378	Disk, Abrasive, No 24 Grit Size, Closed Coat, 112 inch Arbor (81348) P-D-455	EA
27		5345-00-881-8377	Disk, Abrasive, No 36 Grit Size, Closed Coat, In Inch Arbor (81348) P--455	EA
28		5345-00-881-8375	Disk, Abrasive, No 60 Grit Size, Closed Coat, 1/2 inch Arbor (81348) P--455	EA
29		9150-00-985-7237	Fluid, Hydraulic (81349) L-17672	CN
30		5330-00-641-1193	Gasket Material, SHT Compressed 1/16 Inch (81348) HH-P - 6	SH
31		5330-00-171-6551	Gasket Material, SHT Compressed 1/8-inch (81348) HH-P 46	SH
32		8451-00-634-1658	Gloves, Cloth, Leather Palm (81348) JJ-C-451	PR
33		8415-00-033-5458	Gloves, Inserts, fireman's (86692) 1807	EA
34		4240-00-76-5152	Goggles, Industrial, Clear (81348) W-C - 40	EA
35		7240-00-052-3776	Goggles, Plastic, Safety (81348) G-G-531	PR
36		2040-00-238-9060	Grapple, Marine 5 Prong (81348) MIL-G-13	EA
37		9150-00-190 0905	Grease, Auto and Artillery (81348) MIL G-10924	CN
38		9150-00-235-5555	Grease, Ball and Roller Bearing (81348) MIL-G-23549	LB
39		9150-00-530-6814	Grease, Wire Rope Exposed (81348) MIL G-18458/Ship	LB

## SECTION II. EXPENDABLE/DURABLE SUPPLIES AND MATERIAL LIST

(1) ITEM NO.	(2) LEVEL	(3) NATIONAL STOCK NUMBER	(4) DESCRIPTION	(5) U/M
	40	4020-00-24-2161	Halyard, Cotton, Braided, Class 1, 1/4 inch data (81348) MIL-H-226	RL
	41	7920-00-246-0930	Handle, Mop 54 inches Long, Type II, Class 1 (81348) NN-H-104	EA
	42	7920-00-263-0328	Handle, Wood, Acme Thread for use w/ Floor Sweeping Brush, Type 1, Class 1, (81348) MN-H-104	EA
	43	7920-00-141-5452	Handle, Wood, for use w/Rattan Push Broom, Squeegee and Deck Scrub Brush, Type 2 (81348) MN-H-104	EA
	44	6810-00-598-7316	Hypochlorite solution (bleach)	GL
	45	6685-00-075-3496	Inhibitor, Corrosion, Liquid Cooling System (81348) O-I-00490	CN
	46	8010-00-239-5737	Lead, White (Paste In Oil) Type B (81348) TT-W-251	LB
	47	8030-00-829-4554	Locate, Thread Locking	EA
	48	4020-00-240-2185	Marline, Hemp, Type 4, Class 1 (81348) T-R-605	EA
	49	7920-00-171-1148	Mophead, Wet, Cotton, Type 1, Style I (81348) T-M-561	EA
	50	8540-00-285-7001	Napkin, Table Paper (81348)W-N 001650	BX
	51	9150-00-240-2251	Oil, Lub, General Purpose, Mineral (81348) MIL--9000H	CN
	52	9150-00-264 3941	O'l,Lub,PE-10(5galcan) (33333) no ref	CN

## SECTION II. EXPENDABLE/DURABLE SUPPLIES AND MATERIAL LIST

(1) ITEM NO.	(2) LEVEL	(3) NATIONAL STOCK NUMBER	(4) DESCRIPTION	(5) U/M
53		9150-00-405-2987	Oil, Lub, Gear Go 90 (5 gal can) (33333) no ref	CN
54		9150-00-577-5844	Oil, Lub, Gear OE/HDO 40 (185 GL) (33333) no ref	DR
55		9150-00-598-2911	Oil, Lub, Refr Compressor(I qt can) (81348) W-1-825	EA
56		9150-00-257-5440	Oil, Lub, Gos (5 gal can) (81349) MIL L-10324	CN
57		9150-00-117-8791	Oil, Lubrication (for 2 cycle Engine) (54926) TC-W4ubncant	PT
58		4930-00-262-8868	Oiler, Hand, Fex Spout 1 pt (81348) GGG-591	EA
59		6810-00-264-3937	Oxalic Acid	LB
60		5330-00-085-1701	Packing 25' In Self-Dispensing Can 5/32 Inch OD (99189)406 04525	FT
61		8540-00-530-3770	Paper, Toilet (81348) W-P-0558	EA
62		6850-00-001-4194	Paste, Water Indicating (81348) MIL W-83779	OZ
63		7930-00-266 7137	Polish, Metal Type 2, Class 1 (81348) P-P-556	PT
64		7930-00-205-0442	Powder, Scouring (81348) P-S-311	CN
65		7510-00-285-1787	Rubber Bands	BX
66		7510-00-205-0842	Rubber Bands	BX
67		5330-00-641-3051	Rubber Sheet, Solid, 1/16 Inch THK, 36 Inches wide, Type 1, Class 1 (81349) MIL G-1149	EA

## SECTION II. EXPENDABLE / DURABLE SUPPLIES AND MATERIAL LIST

(1) ITEM NO.	(2) LEVEL	(3) NATIONAL STOCK NUMBER	(4) DESCRIPTION	(5) U/M
68		5330-00-729-5103	Rubber Sheet, Solid, 1/8 Inch THK, 36 Inches wide, Type 1, Class I (81349) MIL-G-1149	EA
69		7240-00-052-3776	Safety Glasses	EA
70		4240-00-202-9473	Shield, Face, Industrial Clear (81349) L-F-36	EA
71		4240-00-240-5140	Shield, Face, Industrial Amber (81349) M-S-3126	EA
72		6810-00-262-8567	Sodium Carbonate	LB
73		3439-00-188-6986	Solder, Lead Alloy, Acid Core (81348) OO-S-571	LB
74		3439-00-188-6988	Solder, Lead Alloy, Rosin Core (81348)QQ S-571	LB
75		8135-00-292-2351	Tags, Electrical Wire	
76		5640-00-409-4265	Tape, Duct (45225) Duct Tpe Alum	RO
77		5970-00-185-8531	Tape, Electrical Installation (81348) HH-1-510	RO
78		7510-00-266-6710	Tape, Masking	EA
79		8340-00-205-1863	Tarpauling/Drop Cloth	EA
80		8030-00-889-3534	Teflon Tape	EA
81		8540-00-291-0392	Towels, Paper, C-fold Type (81348) W-1-591	BX
82		7920-00-823-9773	Towels, Paper Machinery Wiping, Type 6 (81348) W-1-595	FT
83		4710-00-277-4026	Tubing, Copper 1/2 Inch (81349) MIL 1-24107	FT



**SECTION II. EXPENDABLE/DURABLE SUPPLIES AND MATERIAL LIST**

(1) ITEM NUMBER	(2) CATEGORY	(3) NATIONAL STOCK NUMBER	(4) DESCRIPTION	(5) U/M
84		4710-00-277-4029	Tubing, Copper 1/4 inch (81349) MIL 1-24107	FT
85		4710-00-277-4027	Tubing, Copper 3/8 Inch (81349) MIL-1-24107	FT
86		4710-00-277-4030	Tubing, Copper 5/16 inch (81349) MIL I-24107	FT
87		7920-00-205-1711	Wiping Rags	EA
88		5970-00-185-8531	Waterproof Tape	EA

**SECTION II. EXPENDABLE / DURABLE SUPPLIES AND MATERIAL LIST**  
**Prepositioned LCU Items**

(1) ITEM NUMBER	(2) LEVEL	(3) NATIONAL STOCK NUMBER	(4) DESCRIPTION	(5) U/M
1		8135-00-721-9725	Aluminum Foil	1 RL
2		7520-01 060 5821	Ball Point Pens (Red)	1 BX
3		7520-00-935-7135	Ball Point Pens, Skillcraft	1 BX
4		3590-00-058-1837	Barber Kit	1 KT
5		6135-00-985-7845	Batteries, M	2 BX
6		6135-00-971-8485	Batteries, 9V	2 BX
7		6135-00-985-7846	Batteries, C Cell	2 BX
8		6135-00-835-7210	Batteries, D Cell	2BX
9		6135-00-643-1310	Batteries, 6V Lantern	2 BX
10		7920-00-926-5244	Budget, Mop	2 EA
11		7530-00-211-4035	Carbon Paper	2 PK
12		8135-00-753-4546	Cellophane	1 RL
13		7510-01-020-2806	Correction Fluid	1 DZ
14		7350-00-641-4511	Cup, Paper, 12 Oz	4 BX
15		6840-00-932-4692	Deodorant, General Purpose	5 BX
16		6840-00-530-7109	Disinfectant, General Purpose	5 GL
17		7210-00-211 1866	Dishcloth	20 EA
18		7930-00-281-4731	Dishwashing-Compound	1 CO
19		7510-00-660-0004	Duct Tape	4RL
20		7510-00-323-8788	Eraser(Gum)	10EA
21		7930-01-183-8585	Finish, Floor, Nonbuffing	1 ON
22		7930-00-926-5280	General Purpose Cleaner	1 BX
23		7930-00-664-6910	Glass Cleaner	1 BX
24		8415-01-134-8232	Gloves, Forest Worker's (Med)	10PR
25		8415-01-130-8233	Gloves, Forest Worker's (Lrg)	4 PR
26		8520-00-082-2164	Hand Cleaner, Waterless	10 TB
27		7530-01-124-7632	Legal Pads (Yellow)	6 EA
28		7530-00-222-3521	Log Books (Large)	8 EA
29		7530-00-222-3525	Log Books (Small)	8 EA
30		7520-00-558-1501	Markers, Tube Type	4 SE
31		7510-00-266-6710	Masking Tape, 2"	4RL

**SECTION II. EXPENDABLE / DURABLE SUPPLIES AND MATERIAL LIST**  
**Prepositioned LCU Items**

(1) ITEM NUMBER	(2) LEVEL	(3) NATIONAL STOCK NUMBER	(4) DESCRIPTION	(5) U/M
32		7920-00-267-1218	Mop Handle	6EA
33		7530-01-124-5660	Note Books or Pads	4PK
34		4020-00-124-2146	Cord, Fibrous, Nylon	2 RL
35		7510-00-286-5755	Pencils, #2 toad	2BX
36		7510-00-240-1526	Pencils, China Marking (Red)	1 DZ
37		7510-00-174-3205	Pencils, China Marking (Blk)	1 DZ
38		6850-00-985-7180	Penetrating Flu-d	3 GL
39		735000-899 3056	Plate, Paper, 9"	4BX
40		4020 00 968-1351	Polypropelene Line, 3/8"	3 RL
41		7920-00-148-9666	Rag, Wiping	6 EA
42		7930 00-045-6912	Remover, Floor Polish	1 CN
43		7510-00-161-6215	Rule, 12"	6 EA
44		7510-00-161-6217	Rule, 18"	6 EA
45		5110-01-241-4375	Scissors	4 EA
46		7930-00-721-8592	Scouring Powder	1 BX
47		6810-00-598-7316	Sodium Hypochlorite (Bleach)	8 BX
48		7920-00-240-2559	Sponges	12 EA
49		7520-00-139-6170	Staplers	2 EA
50		7510-00-272-9662	Staples	2 BX
51		5345-00-215-1881	Stone Assy, Sharpening	2 EA
52		6645 01-106 4303	Stopwatch	1 EA
53		7510-00-082-2520	Tape with Dipenser	6EA
54		8540-00-530-3770	Toilet Paper	2 BX
55		7920-01-177-3633	Towel, Wiping	5 BX
56		8105-01-174-0945	Trash Bags, 11 Gal	1 BX
57		8105-01-221-3236	Trash Bags, 30 Gal	1 BX
58		8105-01-221-3239	Trash Bags, 55 Gal	1 BX
59		7530-00-240-4768	Typing Paper	4BX
60		7530-00-223-7966	Teletype Paper	6 RL
61		7530-01-024-2632	Facsimile Paper	6 RL

**APPENDIX E**

**STOWAGE AND SIGN GUIDE  
FOR COMPONENTS OF END ITEM, BASIC ISSUE  
ITEMS, AND APPLICABLE ADDITIONAL AUTHORIZATION  
LIST ITEMS**

E-1 **Scope** This appendix shows the locations for stowage of equipment and materiel required to be carried on the Landing Craft, Utility (LCU)

E-2 **General** The illustrations below and on the following pages show the location of decals, stencils, and metal signs used on the vessel. Most of these signs mark the places where equipment should be stowed. Some are cautions or information you need to operate the vessel safely.

**E-1/(E-2 blank)**

**APPENDIX F  
SOUNDING TABLES**

<u>Tank</u>	<u>Page</u>
Fuel Tank F-3P.....	F-2
Fuel Tank F-3S.....	F-3
Fuel Tank F-4P.....	F-4
Fuel Tank F-4S.....	F-5
Fuel Tank F-7P.....	F-6
Fuel Tank F-7S.....	F-7
Fuel Day Tank F-12P.....	F-8
Fuel Day Tank F-12S.....	F-9
Bowthruster Fuel Day Tank.....	F-10
Emergency Generator Fuel Day Tank.....	F-11
Fuel Tank FW-6P .....	F-12
Fuel Tank FW-6S .....	F-13
Foam Concentrate Tank.....	F-14
Sludge Oil Tank.....	F-15
Dirty Oil Tank .....	F-16
Lubricating Oil Tank.....	F-17
Hydraulic Oil Tank .....	F-18
Ballast Tank SW-1CL.....	F-19
Ballast Tank SW-2P .....	F-20
Ballast Tank SW-2S .....	F-21
Ballast Tank SW-5P .....	F-22
Ballast Tank SW-5S .....	F-23
Ballast Tank SW-8P .....	F-24
Ballast Tank SW-OS .....	F-25

F-1 **Scope.** This appendix contains sounding tables for the LCU Sounding tables provide a means of converting the depth of fluid contained in a tank to the approximate gallons of fluid in the tank.

F-2 **Using the Tables.** There are two types of tables provided, single column and multiple column. To use these tables, first sound the tank to obtain the measurement of the fluid level. Use the table of contents for this appendix to find the appropriate table.

a Single Column Table. Find the measurement in the left hand column which is closest, to but not over, the sounding reading, read the approximate amount of fluid contained in the tank in the right hand column.

b Multiple Column Table. Find the measurement in feet in the left hand column and read across the table to the right until under the measurement in inches. This is the approximate amount of fluid contained in the tank.

TABLE F-1. SOUNDING TABLE - FUEL TANK F-3P  
 TANK CAPACITIES IN GALLONS FOR EACH INCH OF SOUNDING

SOUNDING IN FEET	SOUNDING IN INCHES											
	0	1	2	3	4	5	6	7	8	9	10	11
0	284	363	441	519	596	688	779	869	959	1050	1140	1234
1	1328	1422	1517	1611	1705	1803	1901	1998	2096	2194	2292	2383
2	2493	2594	2695	2796	2896	2998	3099	3200	3301	3402	3503	3605
3	3706	3807	3909	4010	4111	4212	4314	4415	4516	4618	4719	4821
4	4922	5023	5125	5226	5328	5429	5531	5632	5734	5835	5937	6038
5	6140	6241	6343	6444	6546	6648	6749	6851	6953	7054	7156	7258
6	7359	7461	7563	7664	7766	7868	7970	8072	8173	8275	8377	8479
7	8581	8683	8784	8886	8988	9090	9192	9294	9396	9498	9600	9702
8	9804	9906	10008	10110	10212	10314	10416	10518	10620	10723	10825	10927
9	1029	11131	11233	11335	11438	11540	11642	11744	11847	11949	12051	12153
10	2256	12358	12460	12563	12665	12768	12870	12972	13075	13177	13280	

TABLE F-2. SOUNDING TABLE - FUEL TANK F-3S  
 TANK CAPACITIES IN GALLONS FOR EACH INCH OF SOUNDING

SOUNDING IN FEET	SOUNDING IN INCHES											
	0	1	2	3	4	5	6	7	8	9	10	11
0	264	343	421	509	578	666	756	846	937	1027	1117	1211
1	1305	1399	1493	1587	1681	1778	1876	1974	2072	2170	2268	2368
2	2468	2569	2670	2770	2871	2972	3073	3175	3276	3377	3478	3579
3	3681	3782	3883	3984	4086	4187	4288	4390	4491	4592	4694	4795
4	4897	4998	5099	5201	5302	5404	5505	5607	5708	5810	5911	6013
5	6114	6216	6317	6419	6521	6622	6724	6826	6927	7829	7130	7232
6	7334	7436	7537	7639	7741	7843	7944	8046	8148	8250	8352	8453
7	8555	8657	8759	8861	8963	9065	9167	9269	9370	9472	9574	9676
8	9778	9880	9982	10084	10187	10289	10391	10493	10595	10697	10799	10901
9	11003	11106	11208	11310	11412	11514	11617	11719	11821	11923	12026	12128
10	12230	12333	12435	12537	12640	12742	12844	12947	13049	13152	13254	

TABLE F-3. SOUNDING TABLE - FUEL TANK F-4P  
 TANK CAPACITIES IN GALLONS FOR EACH INCH OF SOUNDING

SOUNDING IN FEET	SOUNDING IN INCHES											
	0	1	2	3	4	5	6	7	8	9	10	11
0	622	757	893	1029	1167	1308	1450	1591	1733	1874	2017	2164
1	2311	2458	2605	2752	2901	3053	3206	3359	3511	3664	3817	3973
2	4128	4284	4439	4595	4750	4905	5061	5216	5372	5527	5683	5838
3	5994	6169	6304	6460	6615	6771	6926	7082	7237	7393	7548	7704
4	7859	8014	8170	8325	8481	8636	8792	8947	9103	9258	9414	9569
5	9724	9880	10035	10191	10346	10502	10657	10813	10968	11124	11279	11435
6	11590	11745	11901	12056	12212	12367	12523	12678	12834	12989	13145	13300
7	13456	13611	13767	13922	14077	14233	14388	14544	14699	14855	15010	15166
8	15321	15477	15632	15788	15943	16099	16254	16410	16565	16720	16876	17031
9	17187	17342	17498	17653	17809	17964	18120	18275	18431	18586	18742	18897
10	19053	19208	19364	19519	19675	19830	19986	20141	20296	20452		



TABLE F-4. SOUNDING TABLE - FUEL TANK F-4S  
 TANK CAPACITIES IN GALLONS FOR EACH INCH OF SOUNDING

SOUNDING IN FEET	SOUNDING IN INCHES											
	0	1	2	3	4	5	6	7	8	9	10	11
0	622	757	893	1029	1167	1308	1450	1591	1733	1874	2017	2164
1	2311	2458	2605	2752	2901	3053	3206	3359	3511	3664	3817	3973
2	4128	4284	4439	4595	4750	4905	5061	5216	5372	5527	5683	5838
3	5994	6149	6304	6460	6615	6771	6926	7082	7237	7393	7548	7704
4	7859	8014	8170	8325	8481	8636	8792	8947	9103	9258	9414	9569
5	9724	9880	10035	10191	10346	10502	10657	10813	10968	11124	11279	11435
6	11590	11745	11901	12056	12212	12367	12523	12678	12834	12989	13145	13300
7	13456	13611	13767	13922	14077	14233	14388	14544	14699	14855	15010	15166
8	15321	15477	15632	15788	15943	16099	16254	16410	16565	16720	16876	17031
9	17187	17342	17498	17653	17809	17964	18120	18275	18431	18586	18742	18897
10	19053	19208	19364	19519	19675	19830	19986	20141	20296	20452		

TABLE F-5. SOUNDING TABLE - FUEL TANK F-7P  
 TANK CAPACITIES IN GALLONS FOR EACH INCH OF SOUNDING

SOUNDING IN FEET	SOUNDING IN INCHES											
	0	1	2	3	4	5	6	7	8	9	10	11
0	29	44	58	73	88	102	117	146	174	203	232	261
1	290	333	376	418	461	504	547	604	661	719	776	833
2	891	963	1036	1109	1181	1254	1327	1413	1499	1584	1670	1756
3	1842	1930	2019	2107	2196	2284	2373	2461	2549	2638	2726	2815
4	2903	2991	3080	3168	3257	3345	3434	3522	3610	3699	3787	3876
5	3964	4053	4141	4229	4318	4406	4495	4583	4671	4760	4848	4937
6	5025	5114	5202	5290	5379	5467	5556	5644	5732	5821	5909	5998
7	6086	6175	6263	6351	6440	6528	6617	6705	6794	6882	6970	7059
8	7147	7236	7324	7412	7501	7589	7678	7766	7855	7943	8031	8120
9	8208	8297	8385	8473	8562	8650	8739	8827	8916	9004	9092	9181
10	9269	9358	9446	9535	9623	9711	9800	9888	9977	10065		

**TABLE F-6. SOUNDING TABLE - FUEL TANK F-7S  
TANK CAPACITIES,-N GALLONS FOR EACH INCH OF SOUNDING**

SOUNDING IN FEET	SOUNDING IN INCHES											
	0	1	2	3	4	5	6	7	8	9	10	11
	29	44	58	73	88	102	117	146	174	203	232	261
1	290	333	376	41B	461	504	547	604	661	719	776	833
2	891	963	1036	1109	1181	1254	1327	1413	1499	1584	1670	1756
3	1842	1930	2019	2107	2196	2284	2373	2461	2549	2638	2726	2815
4	2903	2991	3080	3168	3257	334S	3434	3522	3610	3699	3787	3876
5	3964	4053	4141	4229	4318	4406	4495	4583	4671	4760	4848	4937
6	5025	5114	5202	52gO	5379	5467	5556	5644	5732	5821	5909	5998
7	6086	6175	6263	6351	6440	6528	6617	6705	6794	6882	6970	7059
8	7147	7236	7324	7412	7501	7589	7678	7766	7855	7943	8031	8120
9	8208	8297	8385	8473	8562	8650	8739	8827	8916	9004	9092	9181
10	9269	9358	9446	gS35	9623	9711	9800	9888	9977	10065		

**TABLE F-7. SOUNDING TABLE - FUEL DAY TANK F-12P  
TANK CAPACITIES IN GALLONS**

<b>SOUNDING</b>	<b>CAPACITY (Gallons)</b>
0'0"	0
0'3"	1
0'9"	3
1'0"	34
1'3"	91
1'9"	204
2'3"	319
2'9"	433
3'3"	549
3'9"	666
4'3"	783
4'9"	900
5'3"	1019
5'9"	1138
6'3"	1258
6'9"	1379
7'3"	1500
7'9"	1623
8'3"	1745
8'9"	1869
9'1"	1953
9'3"	1993
9'6"	2056

TABLE F-8. SOUNDING TABLE - FUEL DAY TANK F-12S

TANK CAPACITIES IN GALLONS

SOUNDING	CAPACITY (Gallons)
0'0"	0
0'3"	1
0'9"	3
1'0"	34
1'3"	91
1'9"	204
2'3"	319
2'9"	433
3'3"	549
3'9"	666
4'3"	783
4'9"	900
5'3"	1019
5'9"	1138
6'3"	1258
6'9"	1379
7'3"	1500
7'9"	1623
8'3"	1745
8'9"	1869
9'1"	1953
9'3"	1993
9'6"	2056

**TABLE F-9. SOUNDING TABLE - BOWTHRUSTER FUEL DAY TANK  
TANK CAPACITIES IN GALLONS**

<b>Sounding (Feet-Inches)</b>	<b>Capacity (Gallons)</b>
0'0"	0
0'6"	30
1'0"	59
1'6"	89
2'0"	118
2'6"	148
3'0"	178
3'6"	207
3'9"	225
4'0"	237

**F-10**

TABLE F-10. SOUNDING TABLE - EMERGENCY GENERATOR FUEL DAY TANK

## TANK CAPACITIES IN GALLONS

Sounding (Feet-Inches)	Capacity (Gallons)
0'0"	0
0'4"	12
0'10"	31
1'4"	49
1'10"	68
2'0"	77

**TABLE F-11. SOUNDING TABLE - FUEL TANK FW-6P  
TANK CAPACITIES IN GALLONS FOR EACH INCH OF SOUNDING**

SOUNDING IN FEET	SOUNDING IN INCHES											
	0	1	2	3	4	5	6	7	8	9	10	11
0	136	175	214	253	292	330	369	408	447	486	525	564
1	603	642	680	719	758	797	836	875	914	953	991	1030
2	1069	1108	1147	1186	1225	1264	1302	1341	1380	1419	1458	1497
3	1536	1575	1614	1652	1691	1730	1769	1808	1847	1886	1925	1963
4	2002	2041	2080	2119	2158	2197	2236	2274	2313			



**TABLE F-12. SOUNDING TABLE - FUEL TANK FW-6S  
TANK CAPACITIES IN GALLONS FOR EACH INCH OF SOUNDING**

SOUNDING IN FEET	SOUNDING IN INCHES											
	0	1	2	3	4	5	6	7	8	9	10	11
0	112	151	190	228	267	306	345	384	423	462	501	539
1	578	617	656	695	734	773	812	850	889	928	967	1006
2	1045	1084	1123	1162	1200	1239	1278	1317	1356	1395	1434	1473
3	1511	1550	1589	1628	1667	1706	1745	1784	1822	1861	1900	1939
4	1978	2017	2056	2095	2134	2172	2211	2250	2289	2328		

**TABLE F-13. SOUNDING TABLE - FOAM CONCENTRATE TANK  
TANK CAPACITIES IN GALLONS**

<b>Sounding</b>	<b>Capacity (Gallons)</b>
0'0"	0
0'3"	114
0'9"	229
1'3"	343
1'9"	458
2'3"	573
2'7"	654
2'9"	689

**TABLE F-14. SOUNDING TABLE - SLUDGE OIL TANK  
TANK CAPACITIES IN GALLONS**

<b>Capacity Sounding</b>	<b>(Gallons)</b>
0'0"	0
0'6"	217
1'0"	447
1'6"	677
2'0"	907
2'6"	1136
2'10-1/4"	1298
3'0"	1366

**TABLE F-15. SOUNDING TABLE - DIRTY OIL TANK  
TANK CAPACITIES IN GALLONS**

<b>Capacity Sounding</b>	<b>(Gallons)</b>
0'0"	0
0'5"	99
0'11"	290
1'5"	482
1'11"	673
2'5"	865
2'9"	1003
2'11"	1056

**TABLE F-16. SOUNDING TABLE - LUBRICATING OIL TANK  
TANK CAPACITIES IN GALLONS**

<b>Capacity Sounding</b>	<b>(Gallons)</b>
0'0"	0
0'3"	28
0'9"	83
1'3"	139
1'9"	194
2'3"	250
2'9"	305
3'3"	361
3'9"	417
4'0"	444

**TABLE F-17. SOUNDING TABLE - HYDRAULIC OIL TANK  
TANK CAPACITIES IN GALLONS**

<b>Sounding (Feet-Inches)</b>	<b>Capacity (Gallons)</b>
0'0"	0
0'4"	52
0'10"	129
1'4"	207
1'10"	285
2'4"	362
2'10"	440
3'4"	518
3'10"	595
4'4"	673
4'8"	733
4'10"	751
5'0"	772

**TABLE F-18. SOUNDING TABLE - BALLAST TANK SW-1CL  
TANK CAPACITIES IN GALLONS FOR EACH INCH OF SOUNDING**

SOUNDING IN FEET	SOUNDING IN INCHES											
	0	1	2	3	4	5	6	7	8	9	10	11
0	8	17	26	34	43	52	62	79	96	114	131	149
1	167	195	222	250	277	305	334	373	411	450	489	528
2	568	620	671	723	775	827	880	945	1010	1075	1140	1204
3	1271	1349	1427	1504	1582	1660	1740	1831	1923	2015	2107	2199
4	2292	2396	2499	2603	2707	2810	2916	3031	3146	3262	3377	3493
5	3609	3737	3864	3992	4119	4246	4375	4515	4654	4793	4933	5072
6	5213	5360	5508	5655	5803	5950	6099	6257	6414	6572	6730	6888
7	7046	7207	7368	7528	7689	7850	8011	8175	8340	8504	8669	8833
8	8998	9167	9335	9504	9672	9841	10007	10162	10316	10470	10624	10778
9	10929	11051	11174	11296	11419	11542						

**TABLE F-19. SOUNDING TABLE - BALLAST TANK SW-2P  
TANK CAPACITIES IN GALLONS FOR EACH INCH OF SOUNDING**

SOUNDING IN FEET	SOUNDING IN INCHES											
	0	1	2	3	4	5	6	7	8	9	10	11
0	152	186	243	299	355	412	468	530	608	685	762	840
1	917	998	1091	1184	1277	1369	1462	1558	1664	1770	1876	1982
2	2088	2196	2312	2429	2545	2661	2777	2895	3019	3143	3266	3390
3	3514	3637	3758	3880	4001	4123	4244	4367	4491	4615	4740	4864
4	4988	5113	5240	5367	5494	5621	5747	5870	5979	6088	6198	6307
5	6416	6526	6637	6747	6858	6968	7079	7190	7301	7413	7525	7636
6	7748	7860	7972	8085	8198	8311	8423	8536	8650	8764	8878	8991
7	9105	9219	9334	9449	9564	9679	9793	9909	10025	10140	10256	10372
8	10488	10604	10721	10838	10955	11072	11189	11307	11425	11543	11661	11779
9	11897	12015	12134	12254	12373	12492	12611	12730	12851	12971	13091	13211
10	13331	13452	13573	13694	13816	13937	14058					



**TABLE F-20. SOUNDING TABLE - BALLAST TANK SW-2S  
TANK CAPACITIES IN GALLONS FOR EACH INCH OF SOUNDING**

SOUNDING IN FEET	SOUNDING IN INCHES											
	0	1	2	3	4	5	6	7	8	9	10	11
0	146	172	228	285	341	398	454	511	588	665	743	820
1	897	975	1068	1160	1253	1346	1439	1532	1638	1743	1849	1955
2	2061	2167	2283	2399	2516	2632	2748	2864	2988	3112	3235	3359
3	3483	3606	3728	3849	3971	4092	4214	4335	4460	4584	4708	4833
4	4957	5081	5208	5335	5462	5589	5715	5842	5951	6061	6170	6280
5	6389	6498	6609	6719	6830	6940	7051	7162	7273	7385	7496	7608
6	7720	7831	7944	8057	8170	8282	8395	8508	8621	8735	8849	8963
7	9076	9190	9305	9420	9535	9650	9765	9879	9995	10111	10227	10343
8	10459	10575	10692	10809	10926	11043	11160	11277	11395	11513	11631	11749
9	11867	11985	12104	12224	12343	12462	12581	12700	12820	12940	13061	13181
10	13301	13421	13543	13664	13785	13906	14028					

**TABLE F-21. SOUNDING TABLE - BALLAST TANK SW-5P  
TANK CAPACITIES IN GALLONS FOR EACH INCH OF SOUNDING**

SOUNDING FEET	SOUNDING IN INCHES											
	0	1	2	3	4	5	6	7	8	9	10	11
0	1129	1356	1583	1810	2042	2278	2514	2751	2987	3223	3465	3710
1	3955	4200	4446	4691	4942	5197	5451	5706	5961	6215	6473	6732
2	6991	7250	7509	7769	8028	8287	8546	8805	9065	9324	9583	9842
3	10101	10361	10620	10879	11138	11397	11657	11916	12175	12434	12693	12953
4	13212	13471	13730	13989	14249	14508	14767	15026	15285	15545	15804	16063
5	16322	16581	16841	17100	17359	17618	17877	18137	18396	18655	18914	19173
6	19433	19692	19951	20210	20469	20729	20988	21247	21506	21765	22025	22284
7	22543	22802	23061	23321	23580	23839	24098	24357	24616	24876	25135	25394
8	25653	25912	26172	26431	26690	26949	27208	27468	27727	27986	28245	28504
9	28764	29023	29282	29541	29800	30060	30319	30578	30937	31096	31356	31615
10	31874	32133	32392	32652	32911	33170	33429	33688	33948	34207		

**TABLE F-22. SOUNDING TABLE - BALLAST TANK SW-5S  
TANK CAPACITIES IN GALLONS FOR EACH INCH OF SOUNDING**

SOUNDING IN FEET	SOUNDING IN INCHES											
	0	1	2	3	4	5	6	7	8	9	10	11
0	1157	1383	1610	1837	2071	2307	2543	2779	3015	3251	3494	3739
1	3985	4230	4475	4721	4973	5227	5482	5736	5991	6246	6504	6763
2	7022	7281	7540	7800	8059	8318	8577	8836	9096	9355	9614	9873
3	10132	10392	10651	10910	11169	11428	11688	11947	12206	12465	12724	12984
4	13243	13502	13761	14020	14280	14539	14798	15057	15316	15576	15835	16094
5	16353	16612	16872	17131	17390	17649	17908	18168	18427	18686	18945	19204
6	19464	19723	19982	20241	20500	20760	21019	21278	21537	21796	22056	22315
7	22574	22833	23092	23352	23611	23870	24129	24388	24648	24907	25166	25425
8	25684	25944	26203	26462	26721	26980	27240	27499	27758	28017	28276	28536
9	28795	29054	29313	29572	29832	30091	30350	30609	30868	31128	31387	31646
10	31905	32164	32424	32683	32942	33201	33460	33720	33979	34328		

**TABLE F-23. SOUNDING TABLE - BALLAST TANK SW-8P  
TANK CAPACITIES IN GALLONS FOR EACH INCH OF SOUNDING**

SOUNDING IN FEET	SOUNDING IN INCHES											
	0	1	2	3	4	5	6	7	8	9	10	11
0	29	38	47	56	65	76	91	107	122	138	153	171
1	193	216	238	261	283	308	338	368	398	427	457	489
2	526	564	601	638	675	714	759	803	848	893	937	983
3	1035	1087	1139	1191	1243	1297	1355	1413	1472	1530	1589	1651
4	1716	1780	1845	1909	1974	2039	2107	2175	2243	2312	2380	2448
5	2518	2588	2659	2729	2799	2869	2941	3012	3084	3155	3227	3299
6	3372	3445	3518	3591	3664	3737	3812	3887	3961	4036	4110	4185
7	4262	4338	4414	4480	4566	4643	4721	4798	4876	4954	5032	5110
8	5189	5268	5348	5427	5506	5586	5667	5748	5829	5910	5991	6073
9	6155	6238	6320	6403	6486	6569	6653	6737	6822	6906	6990	7075
10	7161	7246										

**TABLE F-24. SOUNDING TABLE - BALLAST TANK SW-8S  
TANK CAPACITIES IN GALLONS FOR EACH INCH OF SOUNDING**

SOUNDING IN FEET	SOUNDING IN INCHES											
	0	1	2	3	4	5	6	7	8	9	10	11
0	31	40	49	58	67	78	93	109	124	140	155	174
1	196	219	241	264	286	312	342	372	401	431	461	494
2	531	569	606	643	680	720	765	809	854	898	943	990
3	1042	1094	1146	1198	1250	1304	1363	1421	1479	1538	1597	1660
4	1724	1789	1853	1918	1982	2048	2116	2184	2252	2321	2389	2458
5	2528	2598	2668	2738	2808	2878	2950	3022	3093	3165	3236	3308
6	3381	3454	3528	3601	3674	3747	3822	3896	3971	4046	4120	4195
7	4272	4348	4424	4500	4576	4653	4731	4809	4886	4964	5042	5120
8	5200	5279	5358	5438	5517	5597	5678	5759	5840	5921	6002	6083
9	6166	6248	6331	6414	6497	6580	6664	6749	6833	6917	7001	7086
10	7172	7257										

F-25/(F-26 blank)

**APPENDIX G**  
**INSPECTION CHECKLISTS FOR THE LCU-2000**

**Section I. INTRODUCTION**

1. **SCOPE:** This appendix G provides checklists to surveyors and the chief maintenance officers for conducting marine condition surveys and shipyard inspections of US Army watercraft. It provides a standard format for conducting various surveys and inspections and recording the findings. Included is specific guidance for:
  - A. Interim Surveys.
  - B. Pre On Condition Cyclic Maintenance (OCCM) Inspection
  - C. Shipyard Arrival Tests and Inspections.
  - D. Underwater Areas Inspections.
  - E. Work in Process Inspections.
  - F. Dock and Sea Trials.
  
2. **OBJECTIVES:** The specific inspections, surveys, and tests and trials have somewhat different objectives. The overall goal of the program is to insure that the craft is maintained and repaired to the highest standards of safety, seaworthiness and mission readiness. The inspections include all requirements imposed by the United States Coast Guard (USCG) and American Bureau of Shipping (ABS) for similar commercial vessels.
  
3. **MODIFICATION WORK ORDERS (MWO):** Equipment changes and alterations are normally implemented by Modification Work Orders. Funding of these may span several years depending on the urgency of the problem. All users of this Technical Bulletin should ensure that they have an up-to-date file of MWOs and application schedule. Status and application to particular vessels should be examined during each inspection. Complete and partial implementation must be reported to the National Maintenance Point. Once the MWO has been completed, the inspection criteria in this publication will be updated to reflect the new task performance and standards.
  
4. **SAFETY NOTICES and ADVISORIES:** Incidents, accidents, and reported equipment failures may result in safety notices, alerts or an advisory. These will generally be early warning and investigative in nature. Once it has been determined that there is an actual problem, corrective action will be implemented through modification work orders or publication changes. It is essential that an up-to-date file be maintained and utilized in conjunction with this technical bulletin. All users of this bulletin should ensure that they are on the distribution list with the Marine Safety Office, Ft. Eustis, Virginia. Information sharing is essential to maintaining safety. Discoveries of latent defects, equipment failures and problems should result in wide dissemination of information to ensure that it does not predominate throughout the fleet. Deficiencies that are discovered during an inspection that are suspect of repeats with other vessels should be reported to the National Maintenance Point as soon as possible.

**5. INTERIM INSPECTION:** Incidents, accidents, and reported equipment 1. The interim inspection will be accomplished approximately 18 months after completion of a scheduled On Condition Cyclic Maintenance (cyclic dry-docking) period. This inspection will be requested by the unit with a submission of a DA Form 2407.

a. The objectives of the interim inspection are to ensure that the vessel is, in all respects, safe, seaworthy, fully capable of performing its official mission and that it meets all applicable requirements of the various maritime regulatory bodies American Bureau of Shipping (ABS), United States Coast Guard (USCG), Federal Communication Commission (FCC) and Safety of Life at Sea (SOLAS). In addition, any repairs, Direct Support (DS) or General Support (GS) (retail) or National Maintenance Point (NMP) (wholesale), requiring action prior to the next scheduled OCCM period shall be identified and referred to the appropriate maintenance level activity for accomplishment.

b. The interim inspection is a NMP (wholesale) maintenance responsibility.

c. Results of the interim inspection shall be recorded on the combined Interim/Pre-On Condition Cyclic Maintenance Inspection Worksheet, Section 1 of the applicable Appendix.

d. Prior to commencing the interim inspection the surveyor shall meet with the vessel Master and Chief Engineer and unit Maintenance Officer. This meeting will be coordinated through the MACOM headquarters. Unit personnel shall bring to the attention of the surveyor, through the DA form 2404, all known maintenance requirements or operational deficiencies on the craft. The vessel's log books will be reviewed for repairs required, operating hours on main and generator engines, and results of lube oil sampling tests and any abnormal operating conditions.

e. During the interim inspection all major installed equipment and systems shall be operated by the vessel's crew as requested by the surveyor while underway or at pier side, if necessary. Major equipment and systems shall be operated in normal pre-sail check procedures for the inspection.

**NOTE: Mooring lines shall be doubled up during main engine and bowthruster tests and a watch posted to insure that the propellers, rudders, and bow thruster areas are clear, and remain clear. during trials.**

**WARNING: When handling lines, be aware of the danger zone associated with lines in the case of snap back from a parting line, stay out of the bite of lines, do not wear gloves when handling lines, keep hands clear of bits and cleats at all times.**

f. In addition to specific items noted on check lists, any evidence of damage, corrosion or paint deterioration, defective or missing hardware, defective exposed wiring and or unsanitary conditions should be noted on the check lists.

g. During inspection the surveyor shall note and report any unauthorized modification(s) which may have been performed on the vessel. Modification(s) which might effect the safety or seaworthiness of the vessel are particularly important.

h. The crew will have the Ship's Log, Discrepancy Reports and other documentation readily available for reference throughout the inspection.

i. Whenever possible, the interim survey shall include an underwater inspection by an Army or contract diver. See Section 5, Under Water Area Inspection, and applicable Diver Underwater Inspection Report, for additional details.

**6. PRE-ON CONDITION CYCLIC MAINTENANCE (OCCM) INSPECTION:** This inspection shall be accomplished approximately 6 months prior to the next scheduled OCCM period. This inspection will be requested by the unit with a submission of a DA Form 2407.

a. The objectives of the Pre-OCCM inspection are similar to the interim inspection in that it is to ensure that the vessel is in all respects, safe, seaworthy, fully capable of performing its official mission and that it meets all applicable requirements of the various maritime regulatory bodies. In addition, the Pre-OCCM inspection is the basis for developing the repair specifications to be used in the accomplishment of OCCM and identifying maintenance requirements for unit, and DS or GS (retail) accomplishment.

b. The Pre-OCCM inspection is a NMP (wholesale) maintenance responsibility.

c. Results of the Pre-OCCM inspection shall be recorded on the combined Interim/Pre-On Condition Cyclic Maintenance Inspection Worksheet, Section I of the applicable Appendix. In addition to completing the inspection worksheets, the surveyor shall make additional notes as required to facilitate preparation of the repair specification.

d. Prior to commencing the Pre-OCCM inspection the surveyor shall meet with the Vessel Master and Chief Engineer and Unit Maintenance Officer. This meeting will be coordinated through the MACOM headquarters. Unit personnel shall bring to the attention of the surveyor, through the DA form 2404, all known maintenance requirements or operational deficiencies on the craft. The vessel's log books will be reviewed for repairs required, operating hours on main and generator engines, and results of lube oil sampling tests and any abnormal operating conditions.

e. During the Pre-OCCM inspection all major installed equipment and systems shall be operated by the vessel's crew as requested by the surveyor while underway or at pier side, if necessary. Crew assistance shall be provided to the surveyor by operating the various vessels systems and in assisting in tests, e.g., a crew member will be required to operate steering and propulsion controls from the pilot house under direction of the surveyor who will be observing in the steering gear or engine room areas.



**NOTE: Mooring lines shall be doubled up during main engine and bowthruster tests and a watch posted to insure that the propellers, rudders, and bow thruster areas are clear, and remain clear, during trials.**

f. In addition to specific items noted on check lists, any evidence of damage, corrosion or paint deterioration, defective or missing hardware, defective exposed wiring and/or unsanitary conditions should be noted on the check lists or repair specification notes.

g. During the inspection the surveyor shall note and report any unauthorized modification(s) which may have been performed on the vessel. Modification(s) which might effect the safety or seaworthiness of the vessel are particularly important.

h. The crew will have the Ship's Log, Discrepancy Reports and other documentation readily available for reference throughout the inspection.

i. The Pre-OCCM Inspection may reveal shortcomings in the accomplishment of retail maintenance. Upon completion of the inspection, the surveyor will conduct a joint work planning meeting with unit personnel to identify the appropriate maintenance level to determine responsibility for repairs. Requirements effecting material readiness which are beyond the capability of the retail maintenance organization may be considered for inclusion in the specification for accomplishment during the OCCM period.

**7. SHIPYARD ARRIVAL TESTS AND INSPECTIONS:** This Shipyard Arrival Tests and Inspections shall be conducted as soon as practical, but not later than two days after the vessels arrival in the shipyard. The inspection will be conducted by the ship repair contractor (shipyard) with the assigned ship surveyor and vessel representative in attendance IAW AR 56-9.

a. The objective of the Shipyard Arrival Tests and Inspections is to determine any repairs and component renewals required to the vessel which were not detected during the Pre-OCCM inspection or which arose subsequent to the Pre-OCCM inspection. In addition. the contractor cost to accomplish any repairs/renewals detected, and not already contained in the specification, is obtained as part of this inspection

b. Results of the Shipyard Arrival Inspection and Test are recorded by the shipyard and furnished to the ship surveyor and become a part of the contract file. An outline of the scope of the inspection and reporting requirements is shown in Section 3 of the applicable Appendix, Shipyard Arrival Tests and Inspections.

**8. UNDERWATER AREA INSPECTIONS:** There are two types of underwater area inspections: the Dry-Dock Underwater Area Inspection, and the Diver Underwater Area Inspection. The inspection of the underwater areas, both dry-dock and underwater, are a NMP (wholesale) responsibility.

## a. Dry Dock Underwater Area Inspection:

(1) Dry-dock underwater area inspection performed when the vessel is dry-docked. The objective of the dry-dock underwater inspection is to determine the condition of the vessel underwater areas and to determine the repairs and re-preservation required to make the vessel safe and seaworthy until the next dry-docking; normally three years of operation after refloating.

(2). The dry-dock underwater inspection shall include all areas specified in Section 4 of the applicable Appendix, Dry-Dock Underwater Area Inspection. Results of the dry-dock underwater inspection shall be recorded on DA Form 5587-R Report of Dry-docking, Painting and Condition of Vessel Bottom, a copy of which is included in Section 4. Note: This form does not specifically address the bow thruster or keel coolers. Comments on keel cooler and underwater portion of the bow thruster shall be in the remarks section, if applicable. The surveyor is responsible for completing this form.

## b. Diver Underwater Area Inspection:

**WARNING: Follow safety lock out/tag out prior to diving operations on Army watercraft.**

(1). The diver underwater area inspection is performed when the vessel is afloat. This inspection is accomplished whenever possible as part of the interim inspection procedure. The objective of the diver underwater inspection is to determine the condition of the underwater area, appendages and preservation to determine required repairs and services, if any, to maintain the vessel in a safe fully seaworthy and mission capable condition for an additional 18 month interval until the next scheduled dry-docking. In addition, this inspection will identify repairs or services required which, if not acted upon, would lead to more extensive deterioration and major repair expenditures. For example, major paint systems failures permitting excessive corrosion or excessive zinc anode wastage which, if not renewed, might result in accelerated hull corrosion. Zinc anodes deteriorated in excess of 50% of original volume shall be replaced.

(2). The diver underwater inspection shall include all areas specified in Section 5 of the applicable Appendix, Diver Underwater Inspection Report,

c. Ships drawings of the underwater body and appendages shall be provided the diver for familiarization prior to conducting the inspection. If the diver is not qualified to evaluate conditions observed, a closed circuit television with two way communication capable of being monitored by the surveyor shall be used.

**9. WORK -IN-PROCESS INSPECTIONS:** There are two types of underwater area. Work-in-process inspections are accomplished by the assigned ship surveyor while the vessel is in the contractor facility (shipyard) undergoing repairs.

- a. Work-in-process inspections are accomplished by the assigned ship surveyor while the vessel is in the contractor facility (shipyard) undergoing repairs.
- b. The objective of the work-in-process inspections is to insure that work called for in the contract specifications is accomplished as specified and that workmanship and materials are to accepted standards. The work-in-process inspections exclude acceptance dock and sea trials which are addressed in paragraph 10.
- c. No separate in-process inspection report form is included since the scope of each vessel OCCM will vary dependent upon requirements. Normally, the specific check points for a repair task are included in the specification item.
- d. The type of repairs typically requiring Work-In-Process Inspections are listed in Section 6 of the applicable Appendix. This list may be used as a guide in specification preparation.
- e. In addition to Work-In-Process Inspection Checklist, the surveyor will submit a weekly progress report assessing the overall percentage of completion as well as a percentage completion for each major area of repairs. The following guide will be used for the progress report.

**Guide for Computing Percentage of Completion to be Included in Weekly Report**

The weekly progress report shall show the overall job percentage of completion along with the percentage amount of performance period which has been used as of the date of report preparation.

**General Reports**

- 5% 1. Preparation prior to beginning actual work performance
- 10% 2. Make necessary removals to permit access to or removal of designated items for delivery to shop
- 10% 3. Disassembly of items
- 15% 4. Cleaning and inspection of items as designated
- 5% 5. Required reports in hand
- 15% 6. Repair and/or replacement of parts as authorized
- 10% 7. Reassemble and/or test as applicable
- 10% 8. Reinstall all removals in proper location
- 10% 9. Perform operational tests and prove satisfactory
- 5% 10. Clean and paint all disturbed areas
- 5% 11. Furnish surveyor with final operational reports if required by Specification

**Hull Items**

- 5% 1. Preparation prior to beginning actual work performance
- 10% 2. Make necessary removals to permit access to or removal of designated items for delivery to shop
- 10% 3. Disassembly of items
- 15% 4. Cleaning and inspection of items as designated
- 5% 5. Required reports in hand
- 15% 6. Repair and/or replacement of parts as authorized
- 10% 7. Reassemble and/or test as applicable
- 10% 8. Reinstall all removals in proper location
- 10% 9. Perform operational tests and prove satisfactory
- 5% 10. Clean and paint all disturbed areas
- 5% 11. Furnish surveyor with final operational reports if required by Specification

**Electrical Items**

- 5% 1. Preparation prior to beginning actual work performance
- 10% 2. Make necessary removals to permit access to or removal of designated items for delivery to shop
- 10% 3. Disassembly of items
- 15% 4. Cleaning and inspection of items as designated
- 5% 5. Required reports in hand
- 15% 6. Repair and/or replacement of parts as authorized
- 10% 7. Reassemble and/or test as applicable
- 10% 8. Reinstall all removals in proper location
- 10% 9. Perform operational tests and prove satisfactory
- 5% 10. Clean and paint all disturbed areas
- 5% 11. Furnish surveyor with final operational reports if required by Specification

**Machinery Items**

- 5% 1. Preparation prior to beginning actual work performance
- 10% 2. Make necessary removals to permit access to or removal of designated items for delivery to shop
- 10% 3. Disassembly of items
- 15% 4. Cleaning and inspection of items as designated
- 5% 5. Required reports in hand
- 15% 6. Repair and/or replacement of parts as authorized
- 10% 7. Reassemble and/or test as applicable
- 10% 8. Reinstall all removals in proper location
- 10% 9. Perform operational tests and prove satisfactory
- 5% 10. Clean and paint all disturbed areas
- 5% 11. Furnish surveyor with final operational reports if required by Specification

**Note: All additional Specification Work Sheets generated for accomplishing original or new items shall have individual percentage progress entered on report sheet.**

**10. DOCK AND SEA TRIALS:** Dock and Sea Trials are accomplished upon completion of all OCCM contract specification work requirements.

a. The objective of the Dock and Sea trials is to insure that all requirements of the contract work specification have been satisfactorily accomplished and that the vessel is in all respects, safe, fully seaworthy and mission capable.

b. Dock and Sea Trials are performed by the contract shipyard in accordance with the repair specification requirements. The assigned NMP ship surveyor witnesses all dock and sea trials and attests to the satisfactory completion of same. Unit personnel will be present In Accordance With AR 56-9, however, it is in the best interest that the chief engineer and vessel master are present when not specifically required by regulation to observe the trials and ensure the vessel is acceptable. Contractor personnel man the vessel and record all data required by the specification and submit a final report.

c. General and specific requirements for dock and sea trials are contained in Section 7 of the applicable Appendix. The surveyor will also insure all specification items of OCCM contract have been accomplished.

d. Sea Trials as used herein are underway trials which may be conducted on any body of water where there is sufficient water depth and maneuvering space to conduct the specified trials.

**VESSEL CHARACTERISTICS:**

Construction:	Steel
Length:	174 Feet
Beam, Molded:	42 Feet
Depth Molded:	11.5 Feet
Displacement (approximate):	
Light	575 Long Tons (LT)
Loaded:	1087 Long Tons (LT)
Draft, Mean	
Light:	8 Feet
Loaded:	8 Feet, 10 inches
Horsepower:	2500 hp

**Section II. INTERIM AND PRE-ON CONDITION CYCLIC MAINTENANCE (OCCM) INSPECTION**

**1. Wheel House Top.**

**a. Mast, Ladder and Yardarm, Electric Cable and Brackets:**

*Condition:* Inspect for preservation, corrosion, deformation, cracked welds, broken parts, frayed or damaged cable, defective or missing hardware and fasteners.

*Standard:* No conditions exist which adversely effect serviceability, or safety, or which if uncorrected will lead to an unserviceable or unsafe condition. \_\_\_\_\_

\_\_\_\_\_  
\_\_\_\_\_  
\_\_\_\_\_

**b. Navigation Lights:**

*Condition:* Inspect for evidence of leaking, cracked lens, missing hardware and damage.

*Standard:* No evidence of leaks, lens not cracked, all mounting and assembly hardware is intact and serviceable. \_\_\_\_\_

\_\_\_\_\_  
\_\_\_\_\_  
\_\_\_\_\_

**c. ADF Antenna, Cross Loop, Forward on Mast (AN/SRD-26):**

*Condition:* Inspect to verify if installed and securely mounted, mounting hardware all present and not deteriorated and free of corrosion, no physical damage to antenna, no cracks in loops.

*Standard:* Unit is present, securely mounted, all fasteners are present and not deteriorated, there is no damage to loops or cracks in loops. \_\_\_\_\_

---

---

---

**d. Radar Antennas, Port Side SPS-64V17, Stbd Side SPS-64V16:**

*Condition:* Inspect for presence, preservation, corrosion. Inspect mountings for cracks or damage, insure all bolts are present and secure. Inspect for damage to case or antenna, and that warning placard is present. Wave guide intact and undamaged. Power leads undamaged.

*Standard:* Unit present, preservation (paint) sound, no corrosion present, mounting secure, no damage to case or rotating element. Warning placard installed in immediate vicinity. Wave guide not damaged. Power leads in good condition. \_\_\_\_\_

---

---

---

**e. Radio Antennas, VHF-FM Top of Mast, AN/VRC-46 Mast Yardarm Port, AN/VRC-92 Forward of House Top:**

*Condition:* Inspect for presence, and damage. Inspect cables for damage and fraying and secure connections. Inspect mounting hardware for presence, tightness and corrosion.

*Standard:* Units present, undamaged, cables undamaged and secure. Mounting in good condition and corrosion free and secure. \_\_\_\_\_

---

---

---

**f. IFF Antenna (On Mast Yardarm):**

*Condition:* Inspect for antenna presence, damage, secure mounting, and that cable is secure and in good condition.

*Standard:* Unit present, undamaged, securely mounted, cable secure and in good condition. \_\_\_\_\_

---

---

---

---

**g. GPS Antenna (On Mast Yardarm Port Side):**

*Condition:* Inspect for antenna presence, damage, secure mounting and that cable is secure and in good condition.

*Standard:* Unit present, undamaged, securely mounted, cable secure and in good condition.

---

---

---

---

**h. Binnacle and Compass:**

*Condition:* Inspect for presence and completeness, accuracy of heading, operation of lamp and rheostat, and that deviation card is posted and current.

*Standard:* Unit is present and complete, heading is accurate, lamp lights and varies in intensity with rheostat adjustment. Deviation card is posted at binnacle and indicates compass adjustment not more than 12 months prior to time of inspection. \_\_\_\_\_

---

---

---

---

**i. Fire Monitors (2):**

*Condition:* Inspect for presence, damage and corrosion. Exercise shut off valve to prove operation. Elevate and rotate nozzles through entire range to prove free operation.

*Standard:* Units present, undamaged and corrosion free. Shut off valve operates freely. Elevation and rotation operation is smooth and easily performed throughout entire range. \_\_\_\_\_

---

---

---

---



**j. Hand Rails.**

*Condition:* Inspect for preservation corrosion, damage, missing sections or washdown nozzles. (Note: Washdown system activated during fire main system check.)

*Standard:* Paint in good condition, no corrosion, no significant damage, no missing sections or washdown nozzles. \_\_\_\_\_

\_\_\_\_\_  
\_\_\_\_\_  
\_\_\_\_\_

**k. Electrical Receptacles.**

*Condition:* Inspect for corrosion, missing or defective caps, condition of mounting lugs and fasteners, and wire leads.

*Standard:* Caps present and operational, mounting lugs sound and fasteners present and secure, wire lead sound and corrosion free. \_\_\_\_\_

\_\_\_\_\_  
\_\_\_\_\_  
\_\_\_\_\_

**l. Gyro Repeater.**

*Condition:* Inspect for tracking with master gyro, free in swivel, operation of lamp and rheostat, condition of mount and fasteners.

*Standard:* Reads same heading as master gyro, free in swivel, lamp lights and intensity varies with rheostat setting, mount and fasteners are sound and all fasteners are present. \_\_\_\_\_

\_\_\_\_\_  
\_\_\_\_\_  
\_\_\_\_\_

**m. Foam Station No. 2:**

*Condition:* Check for hose test date and pressure and vessel designation marking, nozzle present and in good condition, control valve operation, hose locker preservation and damage, coupling spanner wrench present, marked Foam Station No. 2.

*Standard:* Hose tested and marked with date and pressure within prior 12 months also marked with vessel designation. Nozzle present and undamaged, control valve operates freely, hose locker in good condition, undamaged and preserved, spanner wrench at station, station legibly marked "Foam Station No. 2." \_\_\_\_\_

---

---

---

---

**n. Searchlights:**

*Condition:* Check unit for condition, preservation completeness, check bulb for darkening, lens for cracks, reflector for tarnishing or corrosion. Release focus adjustment lock and check manual focus operation. Leave unlocked for further remote focus check.

*Standard:* Corrosion free, complete, bulb clear, lens in sound condition, reflector in good condition. Manual focus adjustment is operational. (Note: Further checks of searchlight are conducted from pilothouse.) \_\_\_\_\_

---

---

---

---

**2.0 02 Level (External).**

**a. Gyro Repeaters, (Port and Stbd):**

*Condition:* Inspect for tracking with master gyro, free in swivel, operation of lamp and rheostat, condition of mount and fasteners.

*Standard:* Reads same heading as master gyro, free in swivel, lamp lights and intensity varies with rheostat setting, mount and fasteners are sound and all fasteners are present.

---

---

---

---

**b. Wheel House Doors and Windows:**

*Condition:* Inspect door locks, hinges, hold back hooks and eyes, and gaskets. Inspect windows for clear visibility and cracks and leaking gaskets.

*Standard:* Door locks operational, door fits and seals properly, hold back hooks and eyes present and functional. Windows clear and undamaged, no evidence of leakage at window gaskets. \_\_\_\_\_

---

---

---

**c. Inflatable Life Rafts, (2 or 3):**

*Condition:* Inspect for presence, painter condition, attached to vessel properly, damage to container and securing straps. Observe or check vessel records for repack date, repack date may be under rubber hand, check condition of rubber band (Navy raft).

*Standard:* Either 3-fifteen man rafts or 2-twenty five man rafts must be onboard, fixed in cradles with hydrostatic releases and painters attached. Rafts must have inspection date not more than 4 years prior to current date, if Navy style, 1 year if commercial style. Cases and rubber hand (Navy) must be undamaged. Painter not frayed or cut and securely made fast to vessel. \_\_\_\_\_

---

---

---

**d. Hydrostatic Releases:**

*Condition:* Check for presence, damage, proper attachment. If commercial type, inspection date.

*Standard:* Each life raft must have hydrostatic release fitted, show no evidence of damage or tampering and be properly secured to vessel and raft band. Commercial type must have inspection date not more than 1 year prior to current date.

**e. EPIRB:**

*Condition:* Inspect for presence. Verify operation, battery expiration date, hydrostatic release expiration date, and annual registration.

*Standard:* Verify operation by self test, verify battery and hydrostatic release expiration dates (5 year battery, 2 year hydrostatic release) verify annual registration tag is present and not expired. \_\_\_\_\_

---

---

---

**f. Electrical Receptacles:**

*Condition:* Inspect for corrosion, missing or defective caps, condition of mounting lugs and fasteners, and wire leads.

*Standard:* Caps present and operational, mounting lugs sound and fasteners present and secure, wire lead sound and corrosion free. \_\_\_\_\_

\_\_\_\_\_  
\_\_\_\_\_  
\_\_\_\_\_

**g. Lockers, Grenade, Ammo (2), Fuse, Pyrotechnics:**

*Condition:* Inspect for corrosion and preservation damage to lockers, condition of dogs, latches, indicators and ground wires. Check for quantity and expiration date of red parachute flares.

*Standard:* No corrosion or damage, preservation satisfactory, all dogs and hardware present and sound and functional, indicators and ground wires present and functional. Should have 12 red parachute flares, Navy style has no expiration date. Commercial flares good for 3 years from manufacture date. \_\_\_\_\_

\_\_\_\_\_  
\_\_\_\_\_  
\_\_\_\_\_

**h. Exhaust Fans (Toilet and Shower, Galley and Engine Room):**

*Condition:* Inspect that systems are intact and complete, screens present and sound, noise and vibration, doors.

*Standard:* All components fitted and complete, corrosion free, screens in good condition, units run smooth without excessive noise or vibration, doors free to operate and all fasteners functional. \_\_\_\_\_

\_\_\_\_\_  
\_\_\_\_\_  
\_\_\_\_\_

**i. Ladders:**

*Condition:* Inspect treads and handrails and securements for damage and deterioration and corrosion.

*Standard:* No damage, deterioration or corrosion which effects serviceability. Securements sound and corrosion free. \_\_\_\_\_

---

---

---

**j. Manhole to Exhaust Stack:**

*Condition:* Inspect to see if in place, corrosion present, all fasteners in place and condition. Exhaust pipe drain.

*Standard:* Manhole present, corrosion free, all fasteners in place and in good condition. Drain intact and clear.

---

---

---

**k. Work Boat with Motor:**

*Condition:* Inspect for inflation, fiberglass bottom, engine bolted to transom. Paddles, bailer, and life jacket available and condition. Boat cover available.

*Standard:* Fully inflated, fiberglass bottom undamaged and not deteriorated, engine bolted to transom. Paddles, bailer and life jacket aboard and in serviceable condition. Boat cover in place and in serviceable condition. \_\_\_\_\_

---

---

---

**l. Work Boat Davit:**

*Condition:* Inspect for corrosion damage, defects, current load test documentation. Perform operational check of davit rotation, winch, cable, hook, and ball swivel.

*Standard:* No damage or defects, load tested within previous 12 months to 4100 lbs. IAW T B 43-0142. No corrosion present, and unit is operational. Hook and ball swivel free of defects, cracks or deformation. Cable serviceable, with no broken strands, cracked/deformed fittings. \_\_\_\_\_

---

---

---

**m. Antenna, Stbd Aft 35 Ft. Whip HF:**

*Condition:* Inspect ground strap, mounting, warning placard, whip.

*Standard:* Ground strap present, secure and in sound condition. Mountings all present and secure, warning placard present, whip in good condition no damage or deformation:

---

---

---

---

---

**n. Antenna, Port Aft 35 Ft. Whip HF:**

*Condition:* Inspect ground strap, mounting, warning placard, whip.

*Standard:* Ground strap present, secure and in sound condition. Mounting all present and secure, warning placard present, whip in good condition no damage or deformation:

---

---

---

---

---

**o. Fire Station No. 7:**

*Condition:* Inspect hose for test date and pressure and vessel designation marking, shut off valve and nozzle, handle for operating and condition, condition of cabinet and hose, coupling spanner wrench, fire ax. Fire ax marked with vessel designation. Placard indicating station number posted.

*Standard:* Hose marked with test date and pressure within previous 12 months also marked with vessel designation, shut off valve and nozzle handle operates freely, nozzle is clear, cabinet free of corrosion, sound and hinges and latch in serviceable condition, coupling spanner wrench and fire ax present and in serviceable condition, marked with vessel designation. Placard reading "Fire Station No. 7" posted and legible. \_\_\_\_\_

---

---

---

---

---

**p. Battery Box and Batteries:**

*Condition:* Inspect for corrosion and condition of connections and cables, missing caps electrolyte level, condition of box and securing devices, no smoking placard.

*Standard:* Terminals corrosion free, cables undamaged, all caps present, electrolyte above plates, box and securing devices sound and corrosion free. No smoking placard present. \_\_\_\_\_

---

---

---

---

**q. Sternlight and Mast:**

*Condition:* Inspect light lens for cracks and evidence of leaks, wiring condition, mounting, deterioration, damage or corrosion of mast.

*Standard:* No cracks or evidence of leaks on light, wiring sound, mounting secure, no deterioration damage or corrosion of mast. \_\_\_\_\_

---

---

---

---

**r. Rudder Angle Indicators (Port and Stbd):**

*Condition:* Check lamp and rheostat, inspect mounting for securement and corrosion.

*Standard:* Lamp lights and rheostat varies light intensity, mount is secure and corrosion free. \_\_\_\_\_

---

---

---

---

**s. Life Rings, Light and Smoke Flares, (Port and Stbd):**

*Condition:* Inspect for presence and condition, ring marked with vessel designation, light operation, smoke flare expiration date (commercial only), warning placard posted. Check for retro-reflective tape when life rings are inspected.

*Standard:* Life rings present and serviceable, marked with vessel designation, light operates when inverted, smoke flare undamaged and corrosion free, within expiration date if commercial type (3 years after manufacture) (military = none), warning placard is posted. \_\_\_\_\_

---

---

---

---

**t. Sound Powered Telephone:**

*Condition:* Inspect for condition of cabinet, bell and instrument.

*Standard:* Cabinet intact and serviceable, no indication of leakage, instrument and cord and bell present intact and not damaged or deteriorated. \_\_\_\_\_

\_\_\_\_\_  
\_\_\_\_\_  
\_\_\_\_\_

**u. Handrails and Safety Chains:**

*Condition:* Inspect rails for damage, deterioration, completeness and corrosion, safety chains are present and hooks operational.

*Standard:* No damage, deterioration, or corrosion affecting serviceability, no missing sections, safety chains present, sound, and hooks present and serviceable. \_\_\_\_\_

\_\_\_\_\_  
\_\_\_\_\_  
\_\_\_\_\_

**3. 02 Level, Internal (Pilot House).**

**3.1 Forward Center Console.**

**Note:** Controls and instruments related to main propulsion, steering, bow thruster, and ramp operations should be tested/observed during tests of respective systems.

**a. Machinery Plant Monitor System:**

*Condition:* Inspect for proper operation by conducting self diagnostic check, check switch indicator lights and lens.

*Standard:* Self diagnostic check reveals no malfunction. All switches, lights and lens intact and operational.

\_\_\_\_\_  
\_\_\_\_\_  
\_\_\_\_\_



**b. Intercom System.**

*Condition:* Check operation to all stations in send and receive modes, observe lamps, rheostat, controls and selector switch.

*Standard:* Clear effective communication in send and receive modes to all stations from bridge, volume control, lamps, rheostats and selector switches intact and functional.

---

---

---

---

---

**c. General Alarm System:**

*Condition:* Verify operation of all General Alarm bells, verify presence of placard.

*Standard:* Notify all hands of test over P.A. system, sound alarm, ask for report via P.A. or telephone of each of 14 alarms verifying that bell operates and placard is posted "GENERAL ALARM-WHEN BELL RINGS GO TO YOUR STATION". \_\_\_\_\_

---

---

---

---

**d. VHF-FM Radio:**

*Condition:* Verify operation by transmitting and receiving, check external controls and instruments.

*Standard:* Ability to communicate with another station. No damaged or missing controls. \_\_\_\_\_

---

---

---

---

**3.2. Forward Bulkhead, Except Console:**

**a. Rotary Windows, (3).**

*Condition:* Verify operation and visibility.

*Standard:* Windows rotate smoothly and quietly, glass is clear, visibility is not impaired.

---

---

---

---

---

**b. Fixed Windows:**

*Condition:* Inspect for cracks, visibility, and leaks at seals.

*Standard:* No salt penetration between glass and seal, or between seal and metal frame; seal is defective if salt has migrated from exterior to interior. No cracks or degradation of visibility. \_\_\_\_\_

---

---

---

**c. Gyro Compass and Repeater:**

*Condition:* Inspect for correct heading of master, and tracking of repeater, free in swivel, operation of lamp and rheostat, condition of mounts and fasteners.

*Standard:* Heading is correct, repeater heading same as master, free in swivel, lamp lights and varies in intensity with rheostat setting. Mount and fasteners are sound and all fasteners present.

**d. Horn/Whistle:**

*Condition:* Sound in both manual and automatic modes.

*Standard:* Loud blasts in both manual and automatic modes of operation. \_\_\_\_\_

---

---

---

---

**e. Depth Finder:**

*Condition:* Verify operation to include audible and visual alarms.

*Standard:* Observe indicated depth and compare to reading to known depth of water. Should read same as known depth. NOTE: Depth sounder servicing and repair is normally included as part of the OCCM repair specification less the draft of the hull in way of the transponder. In automatic mode the whistle must sound proper blast sequence IAW Title 33 CFR, Part 81, Appendix A, Part D, and Annex III. \_\_\_\_\_  
\_\_\_\_\_  
\_\_\_\_\_

**f. Searchlight:**

*Condition:* Inspect searchlight by operating from pilothouse, check illumination, focusing, elevation, and rotation, check bulb condition and operating hours, cooling fans in light and in power panel, condition of cover and glass.

*Standard:* Lamp lights, focus, elevate and rotate controls are all operational and smooth. Bulb is not blackened and has less than 1500 operating hours, cooling fans in power supply and light both operate and generate air flow, case is undamaged and glass is clear and not cracked. \_\_\_\_\_  
\_\_\_\_\_  
\_\_\_\_\_

**g. Radar (2):**

(1) SPS-64(v)16 Stbd

*Condition:* Perform operation status check.

*Standard:* Displays known objects on screen. \_\_\_\_\_  
\_\_\_\_\_  
\_\_\_\_\_

(2) SPS-64(v)17 Port

*Condition:* Perform operation status check.

*Standard:* Displays known objects on screen. \_\_\_\_\_  
\_\_\_\_\_  
\_\_\_\_\_

**h. Helm:**

Checked concurrent with steering gear tests.

**i. Lifeboat Transmitter (403A):**

*Condition:* Check to verify unit is operational. Check log book entries.

*Standard:* Check with artificial aerial IAW posted placard for transmit capability, check log book for weekly crew check performed. \_\_\_\_\_

\_\_\_\_\_  
\_\_\_\_\_  
\_\_\_\_\_

**3.3 Central Pilot House Console.**

**a. Navigation Light Panel:**

*Condition:* Inspect by checking all switches and lights, tell tale lights and verify alarm.

*Standard:* Navigation lights light in both switch positions, tell tale lamps light, alarm sounds when test switch is activated. \_\_\_\_\_

\_\_\_\_\_  
\_\_\_\_\_  
\_\_\_\_\_

**b. Marine Fire Detection Panel:**

*Condition:* Inspect by activating in self test mode.

*Standard:* Check battery condition. Test results should be as indicated on panel. NOTE: The complete Marine Fire Detection System is normally included in the OCCM repair specification for service and repair.

\_\_\_\_\_  
\_\_\_\_\_  
\_\_\_\_\_

**c. Sound Powered Telephones:**

*Condition:* Check to verify that all stations ring and have send/receive capability.

Standard: Each station rings when called, can ring back, and is capable of clear two way communication.

---

---

---

---

---

**d. Receiver Transmitter RT 1600 KY/U:**

Condition: Verify transmit and receive capability.

Standard: Capable of transmitting and receiving in test. \_\_\_\_\_

---

---

---

---

**e. Distress Signal Receiver R2414/SRQ:**

Condition: Receives distress signals.

Standard: Test results are satisfactory. \_\_\_\_\_

---

---

---

---

**3.4 Aft Stbd Side Bulkhead.**

**a. GPS (AN/WRN-6):**

Condition: Verify position indicated.

Standard: Indicates known position. \_\_\_\_\_

---

---

---

---

**b. Speed Log:**

Condition: Verify satisfactory operation with deck officer.

Standard: Deck officer confirms satisfactory operation. \_\_\_\_\_  
\_\_\_\_\_  
\_\_\_\_\_  
\_\_\_\_\_

**c. Automatic Direction Finder (AN-SRD-26):**

Condition: Verify operational capability with deck officer.

Standard: Deck officer confirms satisfactory operation. \_\_\_\_\_  
\_\_\_\_\_  
\_\_\_\_\_  
\_\_\_\_\_

**d. Facsimile Recorder - Reproducer (RD-60S/UXH):**

Condition: Verify operation capability with deck officer.

Standard: Deck officer confirms satisfactory operation. \_\_\_\_\_  
\_\_\_\_\_  
\_\_\_\_\_  
\_\_\_\_\_

**3.5 Aft Bulkhead, Starboard Side:**

**a. Certificates:**

Condition: Verify that certificates are posted and current.

Standard: Station bill, oil pollution notice, life saving signals and breeches instructions buoy are posted and current. Ref CFR 97.15-35, 97.43 \_\_\_\_\_  
\_\_\_\_\_  
\_\_\_\_\_  
\_\_\_\_\_

**b. Fire Extinguisher No. 18:**

Condition: Inspect for presence, number designation, seal, damage, gage reading, monthly inspections performed.

Standard: Present, numbered, seal intact, damage free, gage reading in "normal" range. Log book should indicate monthly inspection. \_\_\_\_\_

\_\_\_\_\_  
\_\_\_\_\_  
\_\_\_\_\_

**c. Air Conditioner:**

Condition: Verify operational status.

Standard: Operational, blows cool air, no excessive vibration or noise, thermostat controls unit temperature.

\_\_\_\_\_  
\_\_\_\_\_  
\_\_\_\_\_

**3.6 Aft Bulkhead Port Side:**

**a. Tactical RT-524/VRC Receiver Transmitter:**

Condition: Verify operational status with deck officer.

Standard: Deck officer confirms satisfactory operation. \_\_\_\_\_

\_\_\_\_\_  
\_\_\_\_\_  
\_\_\_\_\_

**b. Receiver SSB (R2408/VRC):**

Condition: Verify operational status with deck officer.

Standard: Deck officer confirms satisfactory operation. \_\_\_\_\_

\_\_\_\_\_  
\_\_\_\_\_  
\_\_\_\_\_

**c. Transmitter (T-1527/VRC):**

Condition: Verify operational status with deck officer.

Standard: Deck officer confirms satisfactory operation. \_\_\_\_\_

\_\_\_\_\_  
\_\_\_\_\_  
\_\_\_\_\_

**d. Telegraph Terminal (AN/SGC):**

Condition: Verify operational status with deck officer.

Standard: Deck officer confirms satisfactory operation. \_\_\_\_\_

\_\_\_\_\_  
\_\_\_\_\_  
\_\_\_\_\_

**e. Teletype (AN/UGC-74B(V)3):**

Condition: Verify operational status with deck officer.

Standard: Deck officer confirms satisfactory operation. \_\_\_\_\_

\_\_\_\_\_  
\_\_\_\_\_  
\_\_\_\_\_

**f. Radio Set (AN/URC-92):**

Condition: Verify operational status with deck officer.

Standard: Deck officer confirms satisfactory operation. \_\_\_\_\_

\_\_\_\_\_  
\_\_\_\_\_  
\_\_\_\_\_

**g. Receiver/Transmitter (IFF) AN/APX-72):**

Condition: Verify operational status with deck officer.

Standard: Deck officer confirms satisfactory operation. \_\_\_\_\_

\_\_\_\_\_  
\_\_\_\_\_  
\_\_\_\_\_



**3.7 Console Port Side, Aft.**

**a. Power Panels.**

*Condition:* Inspect visually for condition and damage.

*Standard:* In good condition, no missing parts, no evidence of damage. \_\_\_\_\_  
\_\_\_\_\_  
\_\_\_\_\_  
\_\_\_\_\_

**3.8 Port Bulkhead, Aft:**

**a. Water Fountain:**

*Condition:* Inspect for serviceability, damage, vibration and noise.

*Standard:* Cools water, damage free, no excessive noise or vibration. \_\_\_\_\_  
\_\_\_\_\_  
\_\_\_\_\_  
\_\_\_\_\_

**b. Exposure Suit (2):**

*Condition:* Inspect for tears, cracks, whistle and light, zipper and markings.

*Standard:* No tears or cracks present, whistle and light attached and serviceable, zipper is lubricated and operates freely, unit marked with vessel designation. \_\_\_\_\_  
\_\_\_\_\_  
\_\_\_\_\_  
\_\_\_\_\_

**4.0 01 Level External.**

**a. Damage Control Locker:**

*Condition:* Verify that Fireman's ensembles are present and complete, oxygen breathing apparatus (OBA) and canisters are present and in good condition. Access door in good condition. NOTE: A total of six fireman ensembles and 6 OBAs and 54 OBA canister should be on the vessel stowed between this and the other damage control locker.

Standard: Fireman's ensembles are complete and contents serviceable, each ensemble includes:

- |                          |  |
|--------------------------|--|
| 1 each Gear Bag          | 1 each Fireman's Coveralls or Bunker Coat 1 pair |
| 1 pair Fireman's Gloves  | and Pants  |
| 1 pair Fireman's Boots   | 1 each 2 Cell Explosion Proof Flashlights        |
| 1 each Fireman's Helmet  | 1 each 1/8" x 50 ft Galvanized Lanyard           |
| 1 pair Anti Flash Gloves | 1 each Anti Flash Hood                           |

In addition, OBAs shall be available each with 9 canisters in serviceable condition. Access Watertight door shall operate freely, latches operate freely, gasket soft and fills channel. Hold back hook and eye present and in serviceable condition.

---



---



---



---

**b. Ladder:**

Condition: Inspect treads and handrails and securements for damage and deterioration and corrosion.

Standard: No damage, deterioration or corrosion which effects serviceability. Securements sound and corrosion free.

---



---



---



---

**c. Chocks and Bitts:**

Condition: Inspect for damage, deterioration corrosion.

Standard: No damage or deterioration which effects serviceability, no significant corrosion.

---



---



---



---

**d. Fairleaders:**

Condition: Inspect for free rotation, damage and deterioration.

*Standard:* Rotate freely, no damage or deterioration which effects serviceability, no significant corrosion.

---

---

---

---

---

**e. Stern Anchor Windless:**

*Condition:* Operational check, prove release and retrieve/capability, check fairleaders, and gypsy head. Verify performance of annual preventive maintenance (P/M) services.

*Standard:* Anchor should pay out in both power and free fall modes. Brake should hold anchor, windless should retrieve anchor. Gypsy head should operate in response to controls. Verify that annual P/M services of: draining and refilling reduction gear, cleaning, inspecting and lubricating anchor cable, and cleaning inspecting and preserving bending shackle have been accomplished. \_\_\_\_\_

---

---

---

---

**f. Battery Box/Battery:**

*Condition:* Inspect for corrosion and condition of connections and cables, missing caps, electrolyte level, condition of box and securing devices, no smoking placard posted.

*Standard:* Terminals corrosion free, cables undamaged, all caps present, electrolyte above plates, box and securing devices sound and corrosion free. No smoking placard present. \_\_\_\_\_

---

---

---

---

**g. Hawser Reels:**

*Condition:* Inspect for damage, corrosion and preservation of cable.

*Standard:* No damage, cable corrosion free and preservation applied. \_\_\_\_\_

---

---

---

---

**h. Shore Power Connection Box:**

*Condition:* Inspect for completeness, watertight integrity and condition.

*Standard:* All caps installed, retaining chains attached, all fasteners present and secure, no evidence of damage, leaks or significant corrosion. \_\_\_\_\_

\_\_\_\_\_  
\_\_\_\_\_  
\_\_\_\_\_

**i. Handrails and Safety Chains:**

*Condition:* Inspect rails for damage, deterioration, completeness and corrosion, safety chains are present and hooks operational.

*Standard:* No damage deterioration or corrosion affecting serviceability, no missing sections, safety chains present, sound and hooks present and serviceable. \_\_\_\_\_

\_\_\_\_\_  
\_\_\_\_\_  
\_\_\_\_\_

**j. Sound Powered Telephone and Headset (2):**

*Condition:* Inspect for completeness, condition of enclosure, hatch, seal, hinges, condition of cords and station selector switch.

*Standard:* All components present, enclosure latch operates, hinges free, watertight seal sound, cords and wiring not damaged or deteriorated, selector switch turns freely. \_\_\_\_\_

\_\_\_\_\_  
\_\_\_\_\_  
\_\_\_\_\_

**k. Electrical Receptacles:**

*Condition:* Inspect for corrosion, missing or defective caps, condition of mounting lugs and fasteners, and wire leads.

*Standard:* Caps present and operational, mounting lugs sound and fasteners present and secure, wire lead sound and corrosion free. \_\_\_\_\_

---

---

---

**5.0 01 Level Internal (Quarters).**

**a. Officer and Crew Staterooms:**

*Condition:* Inspect for presence and condition of emergency escape breathing devices, exposure suits and life jackets, sanitary conditions, damaged furnishings, hazardous conditions, space heaters, refrigerators in Master and Chief Engineer Staterooms.

*Standard:* Check emergency escape breathing device expiration date (15 years after manufacture date). Emergency escape breathing devices, exposure suits, and life jackets present in quantities for authorized occupancy. Exposure suits and life jackets fitted with lights and whistle and marked with vessel designation. No vermin or insects or droppings observed. Furnishings in good condition, no damages or deterioration present. No hazardous material present, space heater undamaged and functional. Refrigerators operational (cold interior) no excessive noise or vibration. \_\_\_\_\_

---

---

---

**b. Crew and Officer Heads:**

*Condition:* Inspect for sanitary conditions, leaks in plumbing, missing or damaged items.

*Standard:* Clean and sanitary no mildew odor or vermin. Plumbing fixtures leak free and functional, sink and commode and urinal faucets and flushometers operational and complete. Toilet seat present and undamaged.

---

---

---

---

**c. Laundry Room:**

*Condition:* Verify that washer and dryer are operational, supply and drain piping are leak free, valves operational, space is in sanitary condition.

*Standard:* Washer and dryer operate without excessive vibration or noise. No leaks in supply or drain piping, supply valves shut off leak free. Space is free of vermin, mildew and/or objectionable odors and trash.

---

---

---

---

---

**d. Fire Station (No. 6):**

*Condition:* Inspect hose for test date and pressure and vessel designation marking, shut off valve and nozzle, handle for operating and condition, condition of cabinet and hose, coupling spanner wrench, fire ax. Fire ax marked with vessel designation. Placard indicating station number posted.

*Standard:* Hose marked with test date and pressure within previous 12 months also marked with vessel designation, shut off valve and nozzle handle operates freely, nozzle is clear, cabinet free of corrosion, sound and hinges and hatch in serviceable condition, coupling spanner wrench and fire ax present and in serviceable condition, marked with vessel designation. Placard reading "Fire Station No. 6" posted and legible. \_\_\_\_\_

---

---

---

---

---

**e. Windows:**

*Condition:* Inspect windows for cracks, visibility and leaks at seals.

*Standard:* No cracks, no degradation of visibility, no evidence of leaks. \_\_\_\_\_

---

---

---

---

---

**6.0 Main Deck Aft, External.**

**a. Watertight Doors (4).**

*Condition:* Inspect gaskets, operation, hinges dogs and hold back hooks.

*Standard:* Gasket in good condition undamaged, flexible, fills channel, dogs all operational, hinges undamaged and permit free movement. Hold back hook and eye present and serviceable. \_\_\_\_\_

---

---

---

**b. Bitts (4):**

*Condition:* Inspect for damage, deterioration and corrosion.

*Standard:* No damage or deterioration which effects serviceability, no significant corrosion. \_\_\_\_\_

---

---

---

**c. Fire Stations (No. 3 and 4):**

*Condition:* Inspect hose for test date and pressure and vessel designation marking, shut off valve and nozzle, handle for operating and condition, condition of cabinet and hose, coupling spanner wrench, fire ax. Fire ax marked with vessel designation. Placard indicating station number posted.

*Standard:* Hose marked with test date and pressure within previous 12 months also marked with vessel designation, shut off valve and nozzle handle operates freely, nozzle is clear, cabinet free of corrosion, sound and hinges and latch in serviceable condition, coupling spanner wrench and fire ax present and in serviceable condition, marked with vessel designation. Placard reading "Fire Station No. 3" (on port side) and "Fire Station No. 4" (on stbd side) posted and legible. \_\_\_\_\_

---

---

---

**d. Hatch to Steering Compartment:**

*Condition:* Inspect gasket, perform operational check, check hold back hook and eye.

Standard: Gasket is good condition, undamaged, flexible, fills channel, operating gear moves freely and is functional, hold back hook and eye present and serviceable. \_\_\_\_\_

\_\_\_\_\_  
\_\_\_\_\_  
\_\_\_\_\_

**e. Anchor Fairlead:**

Condition: Inspect for free rotation .without binding.

Standard: Rotates freely by hand without binding. \_\_\_\_\_

\_\_\_\_\_  
\_\_\_\_\_  
\_\_\_\_\_

**f. Anchor, Shackle and Rack:**

Condition: Inspect to see that all are in place and undamaged.

Standard: All present, and no significant damage, no significant corrosion. \_\_\_\_\_

\_\_\_\_\_  
\_\_\_\_\_  
\_\_\_\_\_

**g. Soft Patches:**

Condition: Inspect for all fasteners in place, label plates fitted and legible, watertight (check under deck).

Standard: No missing fasteners, label plates fitted, secure and legible, no evidence of leakage. \_\_\_\_\_

\_\_\_\_\_  
\_\_\_\_\_  
\_\_\_\_\_

**h. Ladders:**

Condition: Inspect treads and handrails and securements for damage and deterioration and corrosion.



*Standard:* No damage, deterioration or corrosion which effects serviceability. Securements sound and corrosion free. \_\_\_\_\_

---

---

---

---

**i. Bulwark:**

*Condition:* Inspect bulwark for damage, deterioration and corrosion.

*Standard:* No significant damage, deterioration or corrosion is present. \_\_\_\_\_

---

---

---

---

**j. Shore Power Cable:**

*Condition:* Inspect for cable and connectors being present and undamaged. Caps present, stowage brackets undamaged.

*Standard:* Cable and connectors present and undamaged, terminal caps and retainer chains present and secure. Stowage brackets in place and undamaged. \_\_\_\_\_

---

---

---

---

**k. Life Rings With Lights (Port and Stbd):**

*Condition:* Inspect for presence and condition, ring marked with vessel designation, light operation. Check for retro-reflective tape when life rings are inspected.

*Standard:* Life ring present and in good condition and marked with vessel designation. Waterlight attached, intact, and lights when inverted. \_\_\_\_\_

---

---

---

---

**l. Electrical Receptacles (3):**

*Condition:* Inspect for corrosion, missing or defective caps, condition of mounting lugs and fasteners, and wire leads.

*Standard:* Caps present and operational, mounting lugs sound and fasteners present and secure, wire lead sound and corrosion free. \_\_\_\_\_

---

---

---

**m. Tank Vents:**

*Condition:* Inspect to insure screens are present and in serviceable condition, check for damage, verify that color coding is IAW TB 43-0144, catchment basin present.

*Standard:* Screens present and undamaged and clear, no damage, painted IAW TB 43-0144, Catchment basin installed below vent. \_\_\_\_\_

---

---

---

**o. Dirty Oil and Sewage Transfer Connections Caps and Switches.**

*Condition:* Inspect, insure caps present, retaining chains intact and secure and functional, check for damage and condition of switches and exposed wiring, check catchment basin. Pipes and caps color coding IAW TB 43-0144.

*Standard:* Pipe caps present, retaining chains in good order, caps and pipes painted IAW TB 43-0144. Verify switches are functional and exposed wiring is serviceable. Catchment basin clear of debris and undamaged.

---

---

---

**7.0 Main Deck Internal**

**7.1 Mess Room.**

**a. Water Fountain:**

*Condition:* Inspect for serviceability, damage, noise and vibration.

Standard: Cools water, damage free, no excessive noise or vibration. \_\_\_\_\_  
\_\_\_\_\_  
\_\_\_\_\_  
\_\_\_\_\_

**b. Intercom:**

Condition: Inspect visually for damage, and completeness.

Standard: No damage, all components intact. \_\_\_\_\_  
\_\_\_\_\_  
\_\_\_\_\_  
\_\_\_\_\_

**c. Refrigerator, Toaster, Coffee Maker, Milk Dispenser, Ice Maker, Drink Dispenser and Cabinets:**

Condition: Verify operational condition and inspect for proper sanitary conditions.

Standard: All equipment is operational, no vermin or insects present. \_\_\_\_\_  
\_\_\_\_\_  
\_\_\_\_\_  
\_\_\_\_\_

**d. Station Bill:**

Condition: Inspect to see if current station bill is posted.

Standard: Station Bill is posted and current. \_\_\_\_\_  
\_\_\_\_\_  
\_\_\_\_\_  
\_\_\_\_\_

**e. Windows:**

Condition: Inspect windows for cracks, visibility and leaks at seals.

Standard: No cracks, no degradation of visibility, no evidence of leaks. No salt penetration between glass and seal, or between seal and metal frame; seal is defective if salt has migrated from exterior to interior. \_\_\_\_\_  
\_\_\_\_\_  
\_\_\_\_\_

**7.2 Galley.**

**a. Cabinets:**

Condition: Inspect for sanitation, overall condition, and damage.

Standard: Sanitary, no food residue odor or insects, latches all operational, no damage.

\_\_\_\_\_  
\_\_\_\_\_  
\_\_\_\_\_  
\_\_\_\_\_

**b. Compactor:**

Condition: Inspect for sanitation and verify operational condition.

Standard: Sanitary condition, no food residue, odor, or insects, item is functional. \_\_\_\_\_

\_\_\_\_\_  
\_\_\_\_\_  
\_\_\_\_\_

**c. Microwave Oven:**

Condition: Inspect for sanitation and verify operational condition.

Standard: Sanitary condition, no food residue, odor, or insects, item is functional. \_\_\_\_\_

\_\_\_\_\_  
\_\_\_\_\_  
\_\_\_\_\_

**d. Sink:**

Condition: Inspect for leaks in supply and drain system, no damage.

Standard: No leaks in supply or drain pipes and valves, supply faucets shut off completely, no damage. \_\_\_\_\_

\_\_\_\_\_  
\_\_\_\_\_  
\_\_\_\_\_

**e. Garbage Disposal:**

Condition: Verify unit is operational.

Standard: Unit operates. \_\_\_\_\_

\_\_\_\_\_  
\_\_\_\_\_  
\_\_\_\_\_

**f. Deep Fryer:**

Condition: Verify unit is operational.

Standard: Unit operates. \_\_\_\_\_

\_\_\_\_\_  
\_\_\_\_\_  
\_\_\_\_\_

**g. Griddle:**

Condition: Verify unit is operational.

Standard: Unit operates. \_\_\_\_\_

\_\_\_\_\_  
\_\_\_\_\_  
\_\_\_\_\_

**h. Range:**

Condition: Verify unit is operational.

Standard: Unit operates. \_\_\_\_\_  
\_\_\_\_\_  
\_\_\_\_\_  
\_\_\_\_\_

**i. Meat Slicer:**

Condition: Verify unit is operational.

Standard: Unit operates. \_\_\_\_\_  
\_\_\_\_\_  
\_\_\_\_\_  
\_\_\_\_\_

**j. Food Mixer:**

Condition: Verify unit is operational.

Standard: Unit operates. \_\_\_\_\_  
\_\_\_\_\_  
\_\_\_\_\_  
\_\_\_\_\_

**k. Refrigerator:**

Condition: Inspect for sanitation, verify operational condition and gasket condition.

Standard: No odor, no moldy food, maintains temperature of 34-36 degrees F. maintained, gasket holds dollar bill firmly. \_\_\_\_\_  
\_\_\_\_\_  
\_\_\_\_\_  
\_\_\_\_\_

**i. Freezer:**

Condition: Inspect for ice build-up, operational condition and gasket condition.

Standard: No ice build-up, maintains temperature of 0-10 degrees F., gasket holds dollar bill firmly. \_\_\_\_\_

\_\_\_\_\_  
\_\_\_\_\_  
\_\_\_\_\_

**m. Dishwasher:**

Condition: Verify operating condition, check for leaks in water supply lines.

Standard: Operates effectively, no leaks present. \_\_\_\_\_

\_\_\_\_\_  
\_\_\_\_\_  
\_\_\_\_\_

**n. Sound Powered Telephone.**

Condition: Inspect for completeness, cord condition and selector switch operation.

Standard: Complete, cord not damaged or frayed, switch operates smoothly. \_\_\_\_\_

\_\_\_\_\_  
\_\_\_\_\_  
\_\_\_\_\_

**o. Electric Panels:**

Condition: Inspect for damage and door latch operation.

Standard: Undamaged, door latches properly. \_\_\_\_\_

\_\_\_\_\_  
\_\_\_\_\_  
\_\_\_\_\_

**p. Fire Extinguisher No. 13:**

Condition: Inspect for presence, number designation, seal, damage, gage reading, monthly inspections performed.

Standard: Present, numbered, seal intact, damage free, gage reading in "normal" range. Log book should indicate monthly inspection. \_\_\_\_\_

---

---

---

---

**q. Gaylord Range Hood:**

*Condition:* Inspect for cleanliness and verify operation.

*Standard:* No grease build up in hood, water wash system operational. Booster Pump inspection is specified in para 7.9.a \_\_\_\_\_

---

---

---

---

**r. Integrated Detergent Washdown System:**

*Condition:* Verify operation.

*Standard:* No evidence of leaks and all spray nozzles open.

**s. Fusible Links in Fire Shutters:**

*Condition:* Inspect to verify installation.

*Standard:* Present on both galley shutters. \_\_\_\_\_

---

---

---

---

**7.3 Provisions Storeroom:**

**a. Sanitary Conditions:**

*Condition:* Inspect to insure space is vermin and insect free, no obnoxious odors, good housekeeping, no trash accumulation, no rotten perishables.

*Standard:* No evidence of insects or vermin, no odors, space is orderly and free of trash, no rotten perishables.

---

---

---



**b. Fire Extinguisher No. 11**

*Condition:* Inspect for presence, number designation, seal, damage, gage reading, monthly inspections performed.

*Standard:* Present, numbered, seal intact, damage free, gage reading in "normal" range. Log book should indicate monthly inspection. \_\_\_\_\_

\_\_\_\_\_  
\_\_\_\_\_  
\_\_\_\_\_

**c. Refrigerator:**

*Condition:* Inspect for sanitation, verify operational condition and gasket condition.

*Standard:* No odor, no moldy food, maintains temperature of 34-36 degrees F. maintained, gasket holds dollar bill firmly. \_\_\_\_\_

\_\_\_\_\_  
\_\_\_\_\_  
\_\_\_\_\_

**d. Freezer:**

*Condition:* Inspect for ice build-up, operational condition and gasket condition.

*Standard:* No ice build-up, maintains temperature of 0-10 degrees F., gasket holds dollar bill firmly. \_\_\_\_\_

\_\_\_\_\_  
\_\_\_\_\_  
\_\_\_\_\_

**e. Vent Fan:**

*Condition:* Verify operational, check for excessive noise or vibration.

*Standard:* Operates without excessive noise or vibration. \_\_\_\_\_

\_\_\_\_\_  
\_\_\_\_\_  
\_\_\_\_\_

**7.4 Sick Bay.**

**a. Sanitation:**

*Condition:* Inspect for vermin and insects, dirt and debris, linens and towels.

*Standard:* No evidence of vermin or insects, dirt, debris or trash, clean linen on bunk and clean towels available. \_\_\_\_\_

\_\_\_\_\_  
\_\_\_\_\_  
\_\_\_\_\_

**b. Refrigerator:**

*Condition:* Inspect for cleanliness, verify operational condition, and check door gasket.

*Standard:* Refrigerator should be clean and empty, should show evidence of cooling within minutes of start up or maintain 34-36° F when operating. Door gasket should retain dollar bill firmly. \_\_\_\_\_

\_\_\_\_\_  
\_\_\_\_\_  
\_\_\_\_\_

**c. Plumbing Fixtures:**

*Condition:* Inspect supply and drain piping for leaks, sink valves should shut off tightly, commode flush operation.

*Standard:* No leaks in supply or drain piping, sink valves leak free when shut, commode flushes satisfactory.

**d. First Aid Kit and Supplies:**

*Condition:* Inspect to verify that kit and supplies are on hand and annual inspection has been performed.

*Standard:* First aid kit and supplies are available. Verify that annual inspection has been performed and entered in vessel log book. FM 21-11 applies. \_\_\_\_\_

\_\_\_\_\_  
\_\_\_\_\_  
\_\_\_\_\_

**e. Intercom:**

*Condition:* Inspect visually for damage, and completeness.

*Standard:* No damage, all components intact. \_\_\_\_\_  
\_\_\_\_\_  
\_\_\_\_\_  
\_\_\_\_\_

**7.5 Arms Control Room.**

**a. Fire Hazards, Fire Detection Equipment and Sprinkler System:**

*Condition:* Inspect for unauthorized flammable material, test heat sensor, sprinkler head present.

*Standard:* No unauthorized flammage materials present, heat sensor activates alarm when heat is applied, sprinkler head in place and unobstructed. \_\_\_\_\_  
\_\_\_\_\_  
\_\_\_\_\_  
\_\_\_\_\_

**b. Lockers:**

*Condition:* Inspect for gear lockers present and adequate provision for securing.

*Standard:* Gear lockers are present and fitted with securing devises. \_\_\_\_\_  
\_\_\_\_\_  
\_\_\_\_\_  
\_\_\_\_\_

**c. Line Throwing Appliance.**

*Condition:* Inspect for presence of line throwing appliance and associated supplies. Verify that all supplies are on hand. Check log book for appliance testing.

*Standard:* Line throwing appliance available with supplies as specified in CFR 46 part 94.45-15 drills to include firing should be conducted and logged every three months. \_\_\_\_\_  
\_\_\_\_\_  
\_\_\_\_\_  
\_\_\_\_\_

**7.6 Air Conditioning and Emergency Generator Room.**

**a. Battery Charger:**

*Condition:* Inspect damage and verify operational condition.

*Standard:* Undamaged and operational. \_\_\_\_\_  
\_\_\_\_\_  
\_\_\_\_\_  
\_\_\_\_\_

**b. Emergency Generator:**

*Condition:* Verify serviceability, check operation in manual mode, trip main generator off line, emergency generator should start and pick up load. Inspect oil pressure water temperature, verify speed control and voltage regulation controls are functional. Inspect for leaks in lube oil, fuel oil, water and exhaust systems. Check log for results of lube oil analyses, oil consumption and weekly functional test. Check for accomplishment of following PM services:

Annual:

- Adjust valve lash clearance
- Inspect drive belt
- Check belt tensioning devise bearing
- Check fan hub
- Renew belt
- Check turbo charger end play and inspect for oil leakage
- Check/tighten mounting bolts
- Check hoses
- Check coolant heater
- Remove and clean magnetic pick up.
- Check generator winding heaters.

Bi-annual:

- Clean cooling system and renew coolant

*Standard:* Emergency generator should pick up electrical load within 45 seconds after tugging main generator off line. Oil pressure 30-60 psi at rated speed, water temperature 180°-190° F. when warmed up, speed controls and voltage regulation functional in both automatic and manual mode. No leaks in fuel and lube oil, water and exhaust systems. Lube oil analysis indicates no abnormal results, oil consumption not excessive. Log book indicates weekly test operation and two hour test run monthly and performance of P/M services listed above.

---

---

---

---

**c. Emergency Switchboard:**

*Condition:* Inspect for grounds (w/ground lamps) instrument readings, switch operation, meter calibration, verify annual cleaning performed.

*Standard:* No grounds are indicated, instruments are functional and bear calibration sticker from last OCCM period, switches are functional, no damage present, verify switchboard cleaned within previous 12 months. NOTE: Calibration of switchboard instruments is normally included as part of the OCCM specifications. \_\_\_\_\_

---

---

---

---

**d. Fixed Fire Fighting System:**

*Condition:* Inspect and observe pressure in tanks, securements, and releases. Check vessel records for accomplishment of annual servicing and 5 year inspection.

*Standard:* Pressure (adjusted for temperature) in normal range. No damage or corrosion or dislocation in securements and release mechanism. Check vessel records for accomplishment of annual weight test of cylinders (CO2) and performance of CFR required 5 year inspection procedures (hydro static cylinders). NOTE: Complete inspection and servicing of the fixed fire fighting system is normally included in OCCM specifications: \_\_\_\_\_

---

---

---

---

**e. Supply Fan:**

*Condition:* Inspect for operation, smooth running, excessive noise or vibration and condition of screen.

*Standard:* Operates, runs smooth without excessive vibration or noise, screen is present, in good condition and securely mounted. \_\_\_\_\_

\_\_\_\_\_  
\_\_\_\_\_  
\_\_\_\_\_

**f. HVAC Unit:**

*Condition:* Inspect while test operating unit for cooling and heating performance, smooth running, unusual noise or excessive vibration of compressors and fans, normal pressures. Verify accomplishment of P/M services of V belt and pulley inspection and inspection/cleaning of evaporator coils.

*Standard:* Unit cools and heats effectively, compressor and fans run smoothly without excessive vibration or noise. Pressures of refrigerant are in normal range. Log book indicates P/M services of V belt and pulley checking and inspection/cleaning of evaporator coils accomplished within preceding 12 months. \_\_\_\_\_

\_\_\_\_\_  
\_\_\_\_\_  
\_\_\_\_\_

**g. Sound Powered Telephone and Headset:**

*Condition:* Inspect for completeness, condition of enclosure, hatch, seal, hinges, condition of cords and station selector switch.

*Standard:* All components present, enclosure latch operates, hinges free, watertight seal sound, cords and wiring not damaged or deteriorated, selector switch turns freely. \_\_\_\_\_

\_\_\_\_\_  
\_\_\_\_\_  
\_\_\_\_\_

**h. Space Heater:**

*Condition:* Inspect for operation, noise and vibration.

*Standard:* Operates, heats air, no excessive noise or vibration. \_\_\_\_\_

\_\_\_\_\_  
\_\_\_\_\_

\_\_\_\_\_  
\_\_\_\_\_

**i. Fire Extinguisher:**

*Condition:* Inspect for presence, number designation, seal, damage, gage reading, monthly inspections performed.

*Standard:* Present, numbered, seal intact, damage free, gage reading in "normal" range. Log book should indicate monthly inspection. \_\_\_\_\_

\_\_\_\_\_  
\_\_\_\_\_  
\_\_\_\_\_

**7.7 Recreation Room** (Note: This space is converted to quarters on some craft. If converted, inspected to same criteria as officer and crew staterooms paragraph 5.0 a.)

**a. Sanitation:**

*Condition:* Inspect for trash or food residue present, foul odors.

*Standard:* No trash, food residue or odor present. \_\_\_\_\_

\_\_\_\_\_  
\_\_\_\_\_  
\_\_\_\_\_

**b. Windows:**

*Condition:* Inspect windows for cracks, visibility and leaks at seals.

*Standard:* No cracks, no degradation of visibility, no evidence of leaks. \_\_\_\_\_

\_\_\_\_\_  
\_\_\_\_\_  
\_\_\_\_\_

**7.8 Passage Ways:**

**a. Engine Room Escape Scuttle:**

*Condition:* Inspect for freedom of operation, gasket condition, operation, and hold back hook and eye.

*Standard:* Operates freely, gasket flexible and fills channel, door operation is not obstructed, hold back hook and eye present and functional. \_\_\_\_\_

---

---

---

**b. Engine Room Manual Control Station:**

*Condition:* Inspect for glass on pull stations, hammers, and damage.

*Standard:* Glass panels are unbroken, hammers and securing chains present and intact. NOTE: Complete service and repair of emergency control station components is normally included as part of the OCCM repair specification.

---

---

---

**7.9 Other**

**a. Foul Weather Gear Locker:**

*Condition:* Inspect foul weather gear, door and locker light, gaylord range hood booster pump for leaks, pressure, and vibration and noise (Note: Operate range hood).

*Standard:* Foul weather gear present and in good condition, door latch and hinges operational, light operational, range hood pump operates, builds up normal pressure, is leak free and does not vibrate, or make excessive noise. \_\_\_\_\_

---

---

---

**b. Damage Control Gear Locker:**

*Condition:* Fireman's outfit present, complete.

*Standard:* Verify weekly drills are performed.

**8.0 Main Deck Cargo Area.**

**a. Deck:**

*Condition:* Inspect for damage, paint condition and corrosion.



Standard: No damage which effects strength or serviceability, paint sound, no significant corrosion. \_\_\_\_\_

\_\_\_\_\_  
\_\_\_\_\_  
\_\_\_\_\_

**b. Bulwarks:**

Condition: Inspection for damage, paint condition, corrosion, condition of mounting brackets.

Standard: No damage which effects strength or serviceability, paint sound, no significant corrosion, mounting brackets intact and damage free. \_\_\_\_\_

\_\_\_\_\_  
\_\_\_\_\_  
\_\_\_\_\_

**c. Soft Patches, Port & Stbd and Over Tunnel.**

Condition: Inspect for leakage and damage.

Standard: Leak free and undamaged. \_\_\_\_\_

\_\_\_\_\_  
\_\_\_\_\_  
\_\_\_\_\_

**d. Gangway and International Shore Connection (Adjacent):**

Condition: Inspect floodlights, walk surface, stanchions and handrails of gangway for completeness and damage. Inspect to see that International Shore Connection is stowed in vicinity.

Standard: All areas complete and intact, no damage present. International shore connection is present. \_\_\_\_

\_\_\_\_\_  
\_\_\_\_\_  
\_\_\_\_\_

**e. Bitts:**

Condition: Inspect for damage or deformation and cracked welds.

Standard: No damage, deformation or cracked welds. \_\_\_\_\_  
\_\_\_\_\_  
\_\_\_\_\_  
\_\_\_\_\_

**f. Cargo Tie Downs:**

Condition: Inspect for damage, debris accumulation and corrosion.

Standard: No damage or debris, or significant corrosion. \_\_\_\_\_  
\_\_\_\_\_  
\_\_\_\_\_  
\_\_\_\_\_

**g. Escape Hatch:**

Condition: Exercise and inspect for freedom of movement of hatching mechanism, condition of gasket and knife edge, and hold back hook and eye.

Standard: Mechanism operates freely, gasket flexible and fills cavity, knife edge smooth and unpainted, hold back hook and eye present and functional. \_\_\_\_\_  
\_\_\_\_\_  
\_\_\_\_\_  
\_\_\_\_\_

**h. Fire Station No. 5:**

Condition: Inspect hose for test date and pressure and vessel designation marking, shut off valve and nozzle, handle for operating and condition, condition of cabinet and hose, coupling spanner wrench, fire ax. Fire ax marked with vessel designation. Placard indicating station number posted.

Standard: Hose marked with test date and pressure within previous 12 months also marked with vessel designation, shut off valve and nozzle handle operates freely, nozzle is clear, cabinet free of corrosion, sound and hinges and latch in serviceable condition, coupling spanner wrench and fire ax present and in serviceable condition, marked with vessel designation. Placard reading "Fire Station No. 5" posted and legible. \_\_\_\_\_  
\_\_\_\_\_  
\_\_\_\_\_  
\_\_\_\_\_

**i. Fixed Fire Fighting System (Paint Locker):**

*Condition:* Inspect and observe pressure in tanks, securements, and releases. Check vessel records for accomplishment of annual servicing and 5 year inspection.

*Standard:* Pressure (adjusted for temperature) in normal range. No damage or corrosion or dislocation in securements and release mechanism. Check vessel records accomplishment of annual weight test of cylinders (CO2) and performance of CFR required 5 year inspection procedures (hydro static cylinders). NOTE: Complete inspection and servicing of the fixed fire fighting system is normally included in OCCM specifications:

---

---

---

---

---

**j. Vents (Supply):**

*Condition:* Inspect for condition of inlet screens, noise and vibration, access plates and fasteners, and corrosion.

*Standard:* Screen in good condition, no excessive noise or vibration from fans, access plates and fasteners present and in good *Condition:* No excessive corrosion. \_\_\_\_\_

---

---

---

---

**k. Overflow Vents, Ballast and Fuel Tanks:**

*Condition:* Inspect to insure screens are present and in serviceable condition, check for damage, verify that color coding is IAW TB 43-0144, catchment basin present.

*Standard:* Screens present and undamaged and clear, no damage, painted IAW TB 43-0144, Catchment basin installed below vent. \_\_\_\_\_

---

---

---

---

**l. Flood Lights:**

*Condition:* Inspect for operation and damage and evidence of leakage.

Standard: Lights light, no damage to case or lens, no evidence of leakage is present. \_\_\_\_\_

\_\_\_\_\_  
\_\_\_\_\_  
\_\_\_\_\_  
\_\_\_\_\_

**m. Davits:**

Condition: Inspect for damage and operation Condition: Check certification.

Standard: No damage, davit free to rotate in socket. (Certification good.) \_\_\_\_\_

\_\_\_\_\_  
\_\_\_\_\_  
\_\_\_\_\_

**n. Fuel Oil Fill Stations (Port and Stbd):**

Condition: Inspect to see that all caps and retained chains are present, secure, catchment present and free of debris, drain plugs present, valves, paint proper color. Inspect operation of emergency fuel oil cutoff wrench and valve.

Standard: Caps and retaining chains present, retaining chains present, secure and in good condition, catchment present, free of debris, drain plugs fitted, valves operate freely, all components painted IAW TB 43-0144. \_\_\_\_

\_\_\_\_\_  
\_\_\_\_\_  
\_\_\_\_\_

**o. Fresh Water Fill Hose and Cabinet:**

Condition: Hose present, blue color, proper identification, cabinet condition and placard spanner wrench. Inspect shut off valve operation.

Standard: Hose is present, in good condition, is blue color, marked "Potable Water", cabinet latch and hinges in good Condition: Identification placard installed, spanner wrench present, shut off valve operates freely. \_\_\_\_\_

\_\_\_\_\_  
\_\_\_\_\_  
\_\_\_\_\_

**p. Electrical Receptacles:**

*Condition:* Inspect for corrosion, missing or defective caps, condition of mounting lugs and fasteners, and wire leads.

*Standard:* Caps present and operational, mounting lugs sound and fasteners present and secure, wire lead sound and corrosion free. \_\_\_\_\_

\_\_\_\_\_  
\_\_\_\_\_  
\_\_\_\_\_

**q. Ramp and Ramp Gasket:**

*Condition:* Inspect for damage, hinge pin wear and lubrication, damage to gasket.

*Standard:* Ramp has no damage effecting serviceability, hinge pins not worn excessively, hinges lubricated, gasket in good condition. \_\_\_\_\_

\_\_\_\_\_  
\_\_\_\_\_  
\_\_\_\_\_

**r. Watertight Doors (3) Forward:**

*Condition:* Inspect gaskets, operation, hinges dogs and hold back hooks.

*Standard:* Gasket in good condition undamaged, flexible, fills channel, dogs all operational, hinges undamaged and permit free movement. Hold back hook and eye present and serviceable. \_\_\_\_\_

\_\_\_\_\_  
\_\_\_\_\_  
\_\_\_\_\_

**s. Life Rings with Line (Port and Stbd):**

*Condition:* Check for retro-reflective tape. Inspect for presence of ring and 90 ft. Of floatable line, ring marked with vessel designation.

Standard: Life rings present and in good condition, line present and secured to ring and in good condition. \_\_\_

---

---

---

---

**t. Sounding Plugs and Access Plugs:**

Condition: Verify plugs can be removed with "T" wrench provided, "T" wrench available, reach rods operational.

Standard: Plugs removable (no frozen in place) "T" wrench present, reach rods operational. \_\_\_\_\_

---

---

---

---

**u. Sounding Tubes:**

Condition: Inspect for holes and excessive deterioration. Inspect weld integrity.

Standard: Good condition and all holes repaired. Painted IAW TB 43-0144. Weld must be solid. \_\_\_\_\_

---

---

---

---

**v. Catwalk Forward of After House:**

Condition: Inspect for damage and corrosion to walkway and handrails and access ladder.

Standard: Structure is undamaged and has no significant corrosion. \_\_\_\_\_

---

---

---

---

**w. Ballast Tanks:**

Condition: Inspect a minimum of three ballast tanks and access ladders.

Standard: Preservative coating in good condition, ladders in good condition, no significant coating failure. \_\_\_\_

\_\_\_\_\_  
\_\_\_\_\_  
\_\_\_\_\_

**9.0 Forecastle Deck (Including A Frame and Mast).**

**9.1 A Frame and Mast.**

**a. Mast:**

**NOTE**  
**Need bucket to perform A-frame inspection.**

Condition: Inspect for preservation, corrosion, deformation, cracked welds, broken parts, frayed or damaged cable, defective or missing hardware and fasteners.

Standard: No conditions exist which adversely effect serviceability, or safety, or which if uncorrected will lead to an unserviceable or unsafe condition. \_\_\_\_\_

\_\_\_\_\_  
\_\_\_\_\_  
\_\_\_\_\_

**b. Navigation Lights:**

Condition: Inspect for evidence of leaking, cracked lens, missing hardware and damage.

Standard: No evidence of leaks, lens not cracked, all mounting and assembly hardware is intact and serviceable. \_\_\_\_\_

\_\_\_\_\_  
\_\_\_\_\_  
\_\_\_\_\_

**c. Whistle:**

Condition: Inspect for secure mounting and damage.

Standard: Whistle fasteners all present and in good condition, no damage present. \_\_\_\_\_

\_\_\_\_\_  
\_\_\_\_\_  
\_\_\_\_\_

**d. Antennas:**

*Condition:* Inspect for presence, and damage. Inspect cables for damage and fraying and secure connections. Inspect mounting hardware for presence, tightness and corrosion.

*Standard:* Units present, undamaged, cables undamaged and secure. Mounting in good condition and corrosion free and secure. \_\_\_\_\_

\_\_\_\_\_  
\_\_\_\_\_  
\_\_\_\_\_

**e. Ladders:**

*Condition:* Inspect for damage and deterioration.

*Standard:* No damage or deterioration which effects safety or serviceability. \_\_\_\_\_

\_\_\_\_\_  
\_\_\_\_\_  
\_\_\_\_\_

**9.2 Forecastle Deck, Port Side.**

**a. Bitts and Chocks:**

*Condition:* Inspect for damage, deterioration and corrosion.

*Standard:* No damage or deterioration which effects serviceability, no significant corrosion. \_\_\_\_\_

\_\_\_\_\_  
\_\_\_\_\_  
\_\_\_\_\_

**d. Fairleaders:**

*Condition:* Inspect for free rotation, damage and deterioration.

*Standard:* Rotate freely, no damage or deterioration which effects serviceability, no significant corrosion. \_\_\_\_

\_\_\_\_\_  
\_\_\_\_\_  
\_\_\_\_\_



**c. Anchor Windlass:**

*Condition:* Perform operational check observe release and retrieve capability, check brake, fairleaders and gypsy head, check reduction gear vent valves, check foundation. Verify performance of annual maintenance services.

*Standard:* Anchor should pay out in both power and free fall modes. Brake should hold anchor, windlass should retrieve anchor. Gypsy head should operate in response to controls. Reduction gear vent valve should be present and clear of obstruction, no cracks in foundation welds. Annual PM service of checking wildcat bushing for wear should have been accomplished with prior 12 months. \_\_\_\_\_

---

---

---

---

**d. Chain Stopper/Devils Claw:**

*Condition:* Inspect for presence, damage, deformation or excessive corrosion.

*Standard:* Item is present, undamaged not deformed and not excessively corroded. \_\_\_\_\_

---

---

---

---

**e. Anchor Chain:**

*Condition:* Inspect for excessive wear or wastage.

*Standard:* Chain does not show evidence of excessive wear or wastage. NOTE: Anchor chain ranging out, sand blasting, inspection, painting and marking is normally included as part of the OCCM repair specification.

---

---

---

---

**f. Sound Powered Telephone:**

*Condition:* Inspect for condition of cabinet, bell and instrument.

*Standard:* Cabinet intact and serviceable, no indication of leakage, instrument and cord and bell present intact and not damaged or deteriorated. \_\_\_\_\_

---

---

**g. Ramp Chain and Cable:**

*Condition:* Inspect for deterioration and wear and corrosion.

*Standard:* Cable not frayed, or damaged, cable is lubricated. No excessive corrosion or wear on chain. \_\_\_\_\_

---

---

---

**h. Bow Ramp Wildcat:**

*Condition:* Inspect by observing during bow ramp test with ramp winch.

*Standard:* No excessive wear, on wildcat lugs, chain links fit properly. \_\_\_\_\_

---

---

---

**i. Bow Ramp Latch:**

*Condition:* Inspect by observing operation during bow ramp test with ramp winch.

*Standard:* Fully operation, latches and unlatches as required, no excessive wear or binding noted. \_\_\_\_\_

---

---

---

**j. Hand Rails and Safety Chains:**

*Condition:* Inspect rails for damage, deterioration completeness and corrosion, safety chains for presence and hooks operational.

*Standard:* No damage deterioration or corrosion affecting serviceability, no missing sections, safety chains present, sound and hooks present and serviceable. \_\_\_\_\_

---

---

---

**k. Life Ring and Light:**

*Condition:* Inspect for presence and condition, ring marked with vessel designation, light operation.

*Standard:* Life ring present and in good condition and marked with vessel designation. Watertight is attached, intact, and lights when inverted. \_\_\_\_\_

\_\_\_\_\_  
\_\_\_\_\_  
\_\_\_\_\_

**l. Electrical Receptacles:**

*Condition:* Inspect for corrosion, missing or defective caps, condition of mounting lugs and fasteners, and wire leads.

*Standard:* Caps present and operational, mounting lugs sound and fasteners present and secure, wire lead sound and corrosion free. \_\_\_\_\_

\_\_\_\_\_  
\_\_\_\_\_  
\_\_\_\_\_

**m. Vent:**

*Condition:* Inspect screen for corrosion and wastage, inspect cover and door and securing devices for condition, completeness and serviceability.

*Standard:* Screen in sound condition, no wastage, cover, door and securing devices are complete, intact and fully functional. \_\_\_\_\_

\_\_\_\_\_  
\_\_\_\_\_  
\_\_\_\_\_

**n. Tie Down Storage Box:**

*Condition:* Inspect for damage, corrosion, cover fit and operation.

*Standard:* No damage or corrosion, cover intact and operational. \_\_\_\_\_

\_\_\_\_\_  
\_\_\_\_\_  
\_\_\_\_\_

**o. Bow Thruster Vent.**

*Condition:* Inspect for condition of screen and operation of ball check.

*Standard:* Screen is present and in good condition, no significant corrosion or wastage. Ball check is operational. \_\_\_\_\_

\_\_\_\_\_  
\_\_\_\_\_  
\_\_\_\_\_

**9.3 Forecastle Deck Stbd Side.**

**a. Bitts and Chocks:**

*Condition:* Inspect for damage, deterioration corrosion.

*Standard:* No damage or deterioration which effects serviceability, no significant corrosion. \_\_\_\_\_

\_\_\_\_\_  
\_\_\_\_\_  
\_\_\_\_\_

**b. Fairleaders:**

*Condition:* Inspect for free rotation, damage and deterioration.

*Standard:* Rotate freely, no damage or deterioration which effects serviceability, no significant corrosion. \_\_\_\_\_

\_\_\_\_\_  
\_\_\_\_\_  
\_\_\_\_\_

**c. Anchor Windlass:**

*Condition:* Perform operational check observe release and retrieve capability, check brake, fairleaders and gypsy head, check reduction gear vent valves, check foundation. Verify performance of annual maintenance services.

*Standard:* Anchor should pay out in both power and free fall modes. Brake should hold anchor, windlass should retrieve anchor. Gypsy head should operate in response to controls. Reduction gear vent valve should be present and clear of obstruction, no cracks in foundation welds. Annual PM service of checking wildcat bushing for wear should have been accomplished with prior 12 months. \_\_\_\_\_

---

---

---

**d. Chain Stopper/Devils Claw:**

*Condition:* Inspect for presence, damage, deformation or excessive corrosion.

*Standard:* Item is present, undamaged not deformed and not excessively corroded. \_\_\_\_\_

---

---

---

**e. Anchor Chain:**

*Condition:* Inspect for excessive wear or wastage.

*Standard:* Chain does not show evidence of excessive wear or wastage. NOTE: Anchor chain ranging out, sand blasting, inspection, painting and marking is normally included as part of the OCCM repair specification.

---

---

---

**f. Sound Powered Telephone:**

*Condition:* Inspect for condition of cabinet, bell and instrument.

*Standard:* Cabinet intact and serviceable, no indication of leakage, instrument and cord and bell present intact and not damaged or deteriorated. \_\_\_\_\_

---

---

---

**g. Ramp Chain and Cable:**

*Condition:* Inspect for deterioration and wear and corrosion.

*Standard:* Cable not frayed, damaged, cable lubricated. No excessive corrosion or wear on chain. \_\_\_\_\_

---

---

---

**h. Bow Ramp Wildcat:**

*Condition:* Inspect by observing during bow ramp test with ramp winch.

*Standard:* No excessive wear, on wildcat lugs, chain links fit properly. \_\_\_\_\_

---

---

---

**i. Bow Ramp Latch:**

*Condition:* Inspect by observing operation during bow ramp test with ramp winch.

*Standard:* Fully operation, latches and unlatches as required, no excessive wear or binding noted. \_\_\_\_\_

---

---

---

**j. Hand Rails and Safety Chains:**

*Condition:* Inspect rails for damage, deterioration completeness and corrosion, safety chains for present and hooks operational.

*Standard:* No damage deterioration or corrosion affecting serviceability, no missing sections, safety chains present, sound and hooks present and serviceable. \_\_\_\_\_

---

---

---

**k. Life Ring and Light:**

*Condition:* Check for retro-reflective tape. Inspect for presence and condition, ring marked with vessel designation, light operation.

*Standard:* Life ring present and in good condition and marked with vessel designation. Watertight is attached, intact, and lights when inverted. \_\_\_\_\_

\_\_\_\_\_  
\_\_\_\_\_  
\_\_\_\_\_

**l. Electrical Receptacles:**

*Condition:* Inspect for corrosion, missing or defective caps, condition of mounting lugs and fasteners, and wire leads.

*Standard:* Caps present and operational, mounting lugs sound and fasteners present and secure, wire lead sound and corrosion free. \_\_\_\_\_

\_\_\_\_\_  
\_\_\_\_\_  
\_\_\_\_\_

**m. Escape Hatch:**

*Condition:* Inspect for freedom of operation, hatching mechanism operation, gasket condition, and seating surface.

*Standard:* Hatch opens and closes freely, latch mechanism operates freely, gasket is soft and fills gasket cavity (no gaps) coaming is smooth and undamaged. \_\_\_\_\_

\_\_\_\_\_  
\_\_\_\_\_  
\_\_\_\_\_

**n. Tie Down Storage Box:**

*Condition:* Inspect for damage, corrosion, cover fit and operation.

*Standard:* No damage or corrosion, cover intact and operational. \_\_\_\_\_

\_\_\_\_\_  
\_\_\_\_\_  
\_\_\_\_\_

**10.0 Main Deck Enclosures - Forward.**

**10.1 Stbd Side (Bosn Locker).**

**a. Ramp Winch:**

*Condition:* Test operate and inspect, raise and lower ramp from all control stations, observe latch and wildcat operations during test. Check operation of cable slack switch, and check that winch guards are in place and functional. Verify accomplishment of PM services.

*Standard:* Ramp can be lowered and raised from each control station. Ramp latch, latches and releases without binding, and is not worn, wildcat lugs or bushing are not worn excessively. Winch and cable guards are in place and functional. Cable slack switch operates to stop winch on slack cable conditions.

Verify accomplishment of PM services of:

Annual: Change oil in winch gear reduces and inspect hydraulic pump flexible coupling insert.

Bi-annual: Change hydraulic fluid and clean suction strainer element.

---

---

---

---

---

**b. Escape Trunk Ladder:**

*Condition:* Inspect for proper securement, condition and serviceability and obstruction.

*Standard:* Properly secured, no damage or deterioration which effects serviceability, access to ladder is not obstructed.

---

---

---

---

---

**c. Sound Powered Telephone:**

*Condition:* Inspect for condition of cabinet, bell and instrument.



Standard: Cabinet intact and serviceable, no indication of leakage, instrument and cord and bell present intact and not damaged or deteriorated. \_\_\_\_\_

\_\_\_\_\_  
\_\_\_\_\_  
\_\_\_\_\_

**d. Bow Anchor Winch Power Unit:**

Condition: Inspect during anchor winch tests for leaks, vibration noise, and hydraulic fluid level.

Standard: Leak free operation, no excessive noise or vibration, hydraulic fluid at "normal" level. \_\_\_\_\_

\_\_\_\_\_  
\_\_\_\_\_  
\_\_\_\_\_

**e. Space Heater:**

Condition: Inspect for operation, noise and vibration.

Standard: Operates, heats air, no excessive noise or vibration. \_\_\_\_\_

\_\_\_\_\_  
\_\_\_\_\_  
\_\_\_\_\_

**f. General:**

Condition: Inspect for missing, deteriorated or damaged insulation, corrosion, paint deterioration and housekeeping.

Standard: Insulation in good condition no damage or missing areas, no excessive corrosion or paint deterioration, contents of space are "ship shape", no hazards present. \_\_\_\_\_

\_\_\_\_\_  
\_\_\_\_\_  
\_\_\_\_\_

**10.2 Stbd Side, Damage Control Locker.**

**a. Damage Control Gear:**

*Condition:* Verify that Fireman's ensembles are present and complete, oxygen breathing apparatus (OBA) and canisters are present and in good *Condition:* NOTE: A total of six fireman ensembles and 6 OBAs and 54 OBA canister should be on the vessel stowed between this and the other damage control locker.

*Standard:* Fireman's ensembles are complete and contents serviceable, each ensemble includes:

- |                          |   |
|--------------------------|---|
| 1 each Gear Bag          | 1 each Fireman's Coveralls or Bunker Coat and Pants |
| 1 pair Fireman's Gloves  | 1 each 2 Cell Explosion Proof Flashlight            |
| 1 pair Fireman's Boots   | 1 each 1/8" x 50 ft Galvanized Lanyard              |
| 1 each Fireman's Helmet  | 1 each Anti Flash Hood                              |
| 1 pair Anti Flash Gloves |   |

In addition, OBAs shall be available each with 9 canisters in serviceable condition.

---



---



---

**b. Watertight Door:**

*Condition:* Inspect gaskets, operation, hinges dogs and hold back hooks.

*Standard:* Gasket in good condition undamaged, flexible, fills channel, dogs all operational, hinges undamaged and permit free movement. Hold back hook and eye present and serviceable. \_\_\_\_\_

---



---



---

**10.3 Port Side (Paint Locker).**

**a. Fixed Fire Fighting System.**

*Condition:* Inspect and observe pressure in tanks, securements, and releases. Check vessel records for accomplishment of annual servicing and 5 year inspection.

Standard: Pressure (adjusted for temperature) in normal range. No damage or corrosion or dislocation in securements and release mechanism. Check vessel records accomplishment of annual weight test of cylinders (CO2) and performance of CFR required 5 year inspection procedures (hydrostatic cylinders). NOTE: Complete inspection and servicing of the fixed fire fighting system is normally included in OCCM specifications:

---

---

---

---

---

**b. Presence of Hazardous Conditions:**

Condition.: Inspect for hazardous conditions or unauthorized hazardous material.

Standard: No hazardous conditions or unauthorized materials present. \_\_\_\_\_

---

---

---

---

**c. Vent Fan:**

Condition: Verify operational condition, check for excessive noise or vibration.

Standard: Operates without excessive vibration or noise. \_\_\_\_\_

---

---

---

---

**d. Space Heater:**

Condition: Inspect for operation, noise and vibration.

Standard: Operates, heats air, no excessive noise or vibration. \_\_\_\_\_

---

---

---

---

**11.0 Engine room (Except Control Station).**

**a. Air Compressors:**

*Condition:* Operational test, check capacity, check for inspection tags on reservoirs and relief valves, check oil pressure when warmed up.

*Standard:* Units are operational, capable of pumping 200 gal reservoir to 175 psi from empty in less than 12 minutes. Test tags indicate test at previous OCCM (313 psi for tanks, 220 psi for relief valves, oil pressure 18-20 psi when warmed up. NOTE: OCCM specification will normally provide for hydrostatic test of reservoir and setting of relief valves. \_\_\_\_\_

\_\_\_\_\_  
\_\_\_\_\_  
\_\_\_\_\_

**NOTE: On some craft air compressors are located in tunnel, same procedure applies.**

**b. Sea Water Cooling Pump:**

*Condition:* Verify operational condition inspect for leaks, normal pressure.

*Standard:* Unit operates and maintains pressure without excessive vibration or noise, no leaks from shaft seal or piping or pipe joints and flanges. \_\_\_\_\_

\_\_\_\_\_  
\_\_\_\_\_  
\_\_\_\_\_

**c. Stbd Main Engine Including Reduction Gear, Propeller Shaft, and Bearings, Shaft Brake and Controls:**

*Condition:* Test operates at dock or underway. Inspect for leaks (lube oil, fuel oil, water, and exhaust gas). Check temperatures and pressures for normal readings. Check engine response to control both reversing and acceleration from all stations. Check for vibration, of all components. Check shaft brake operation. Review log for unusual or abnormal operating conditions or incidents. Review oil analysis reports and oil consumption records for abnormal conditions and excessive oil consumption. Check log for accomplishment of following P/M services as applicable:

Annual

- Adjust injectors, crossheads and valves
- Check/replace hoses
- Check/tighten mounting bolts

- Check safety controls
- Inspect reduction gears

Bi-annual

- Clean and calibrate injectors
- Check turbocharger clearances
- Check vibration dampner
- Clean crankcase breather
- Replace water pump

**NOTE: Inspect exhaust system integrity. Check for leaks. Draining and flushing of the engine cooling system is required at 36 month intervals, this is normally included in the OCCM repair specification.**

*Standard:* No leaks in lube oil, fuel oil, water and exhaust systems. Engine oil pressure should be 20 psi at idle, 45-70 psi at full speed. Water temperature should not exceed 195° F at full speed. Reduction gear oil pressure should be 250 psi when gear is warmed up. Engine responds smoothly to controls from all stations without surging or hesitation. Engine and drive train do not vibrate excessively. Shaft brake engages within 7 seconds when engine is shifted into stop and releases immediately when engine is shifted to ahead or astern operation. Oil analysis reports and oil consumption should indicate normal conditions and consumption. Log should indicate accomplishment of all required P/M services listed above as applicable (annual services at interim inspection, annual and bi-annual services at pre-OCCM inspection).

---

---

---

---

---

**d. Port Main Engine, Including Reduction Gear, Propeller Shaft, Bearings, Shaft Brake and Controls.**

*Condition:* Test operates at dock or underway. Inspect for leaks (lube oil, fuel oil, water, and exhaust gas). Check temperatures and pressures for normal readings. Check engine response to control both reversing and acceleration from all stations. Check for vibration. of all components. Check shaft brake operation. Review log for unusual or abnormal operating conditions or incidents. Review oil analysis reports and oil consumption records for abnormal conditions and excessive oil consumption. Check log for accomplishment of following P/M services as applicable:

Annual

- Adjust injectors, crossheads and valves

- Check/replace hoses
- Check/tighten mounting bolts
- Check safety controls
- Inspect reduction gears

Bi-annual

- Clean and calibrate injectors
- Check turbocharger clearances
- Check vibration dampner
- Clean crankcase breather
- Replace water pump

**NOTE: Inspect exhaust system integrity. Check for leaks. Draining and flushing of the engine cooling system is required at 36 month intervals, this is normally included in the OCCM repair specification.**

*Standard.* No leaks in lube oil, fuel oil, water and exhaust systems. Engine oil pressure should be 20 psi at idle, 45-70 psi at full speed. Water temperature should not exceed 195° F at full speed. Reduction gear oil pressure should be 250 psi when gear is warmed up. Engine responds smoothly to controls from all stations without surging or hesitation. Engine and drive train do not vibrate excessively. Shaft brake engages within 7 seconds when engine is shifted into stop and releases immediately when engine is shifted to ahead or astern operation. Oil analysis reports and oil consumption should indicate normal conditions and consumption. Log should indicate accomplishment of all required P/M services listed above as applicable (annual services at interim inspection, annual and bi-annual services at pre-OCCM inspection).

---

---

---

---

---

**e. Stbd Main Generator:**

*Condition:* Test operate, observe that unit accepts, shares, and transfers load, unit responds to speed and load sharing controls, substantially constant frequency is maintained during load changes, overspeed trip is operational. Inspect fuel oil, lube oil, engine cooling water and exhaust systems (check lagging) for leaks. Pressures and temperatures are in normal range. Observe for excessive vibration. Review log for unusual or abnormal operating conditions or incidents. Review oil analysis reports and oil consumption records for abnormal conditions and excessive oil consumption. Check log for accomplishment of following P/M services as applicable:

Annual

- Adjust valves and injectors
- Check/replace hoses
- Check/tighten turbo charge mounting bolts
- Check/tighten engine mounting bolts
- Check crankshaft and clearance
- Check safety controls
- Remove and clean magnetic pick up

Bi-annual

- Replace injectors as necessary
- Replace fuel pump as necessary
- Check turbocharger clearances
- Check vibration dampner
- Replace water pump and idler pulley

**NOTE: Draining and flushing of the generator engine cooling system is required at 36 month intervals. This is normally included in the OCCM repair specification.**

*Standard:* Unit operates, accepts, shares and transfers load, responds to speed and load sharing controls smoothly and without hesitation or surging. Frequency is maintained substantially constant over load range. Overspeed trip operates to shut down unit. Fuel oil, lube oil, engine cooling water and exhaust systems are leak free. Pressure and temperatures are within normal ranges, oil pressure minimum 18 psi, at idle, 45 psi at 1800 RPM, water temperature less than 215° F at full load. No abnormal lube oil analysis reports or excessive oil consumption. P/M services listed above have been accomplished as applicable (annual services at interim inspection, annual and bi-annual inspections at the Pre-OCCM inspection. \_\_\_\_\_

---



---



---

**f. Battery Storage Boxes and Batteries (2):**

*Condition:* Inspect for corrosion and condition of connections and cables, missing caps electrolyte level, condition of box and securing devices, no smoking placard.

*Standard:* Terminals corrosion free, cables undamaged, all caps present, electrolyte above plates, box and securing devices sound and corrosion free. No smoking placard present. \_\_\_\_\_

---



---



---

---



---

**g. Battery Charger:**

*Condition:* Verify operational capability including ammeter, inspect for damage and completeness.

*Standard:* Charger is operational, ammeter functions, unit is complete and undamaged.

---



---



---



---

**h. Port Main Generator:**

*Condition:* Test operate, observe that unit accepts, shares, and transfers load, unit responds to speed and load sharing controls, substantially constant frequency is maintained during load changes, overspeed trip is operational. Inspect fuel oil, lube oil, engine cooling water and exhaust systems (check lagging) for leaks. Pressures and temperatures are in normal range. Observe for excessive vibration. Review log for unusual or abnormal operating conditions or incidents. Review oil analysis reports and oil consumption records for abnormal conditions and excessive oil consumption. Check log for accomplishment of following P/M services as applicable:

Annual

- Adjust valves and injectors
- Check/replace hoses
- Check/tighten turbo charge mounting bolts
- Check/tighten engine mounting bolts
- Check crankshaft and clearance
- Check safety controls
- Remove and clean magnetic pick up

Bi-annual

- Replace injectors as necessary
- Replace fuel pump as necessary
- Check turbocharger clearances
- Check vibration dampner
- Replace water pump and idler pulley

**NOTE: Draining and flushing of the generator engine cooling system is required at 36 month intervals. This is normally included in the OCCM repair specification.**



*Standard:* Unit operates, accepts, shares and transfers load, responds to speed and load sharing controls smoothly and without hesitation or surging. Frequency is maintained substantially constant over load range. Overspeed trip operates to shut down unit. Fuel oil, lube oil, engine cooling water and exhaust systems are leak free. Pressure and temperatures are within normal ranges, oil pressure minimum 18 psi, at idle, 45 psi at 1800 RPM, water temperature less than 215° F at full load. No abnormal lube oil analysis reports or excessive oil consumption. P/M services listed above have been accomplished as applicable (annual services at interim inspection, annual and bi-annual inspections at the Pre-OCCM inspection. \_\_\_\_\_

---

---

---

---

**i. Reduction Gear Cooling Pumps:**

*Condition:* Observe during operation for vibration, noise, leaks and maintenance of 30 psi pressure.

*Standard:* Operational, with no excessive vibration or noise, 30 psi pressure is maintained, shaft gland and piping, pipe joints and flanges are leak free. \_\_\_\_\_

---

---

---

---

**j. Marine Sanitation System and Surge Tank:**

*Condition:* Verify operational condition, inspect for evidence of leaks.

*Standard:* Fully operational, valves, pumps and piping systems are leak free. \_\_\_\_\_

---

---

---

---

**k. Prelube Pump:**

*Condition:* Verify operational condition, inspect valves, pumps and associated piping for evidence of leaks.

Standard: Fully operational, no excessive vibration or noise, valves, pumps and associated piping are leak free.

---

---

---

---

**I. Oil Water Separator System:**

Condition: Verify operational condition, inspect for evidence of leaks.

Standard: Fully operational, valves, pumps and piping systems are leak free. \_\_\_\_\_

---

---

---

---

**m. Purifier, Lube Oil:**

Condition: Verify operational condition, inspect valves, pumps and associated piping for evidence of leaks.

Standard: Fully operational, no excessive vibration or noise, valves, pumps and associated piping are leak free.

---

---

---

---

**n. Watermakers (2):**

Condition: Verify operational condition and capacity, inspect components for damage deterioration, completeness and serviceability.

Standard: Fully operational, output capacity is not less than 85% of rating. Units are complete with no damaged, deteriorated, or unserviceable components. \_\_\_\_\_

---

---

---

---

**o. Electrical Panels:**

Condition: Verify operational condition, inspect for damage or deterioration, inspect associated electrical cables for secure attachment and condition.

Standard: Fully operational, no damage or deterioration, wiring in good condition and secure. \_\_\_\_\_

\_\_\_\_\_  
\_\_\_\_\_  
\_\_\_\_\_

**p. Air Receiver:**

Condition: Inspect for presence of test data plate from last OCCM, inspect relief valve for inspection tag and test operate. Verify that automatic drain valve is operational.

Standard: Tank has tag or plate indicating hydrostatic test and relief valve has tag indicating test not over 36 months previous to inspection. Relief valve operates when lifted by hand, automatic drain valve is operational.

\_\_\_\_\_  
\_\_\_\_\_  
\_\_\_\_\_

**NOTE: The air receiver tank and relief valve are normally included in the OCCM specification, the tank for hydrostatic testing to 313 psi and the relief valve for setting to 220 psi.**

**q. Fire Station No. 1:**

Condition: Inspect hose for test date and pressure and vessel designation marking, shut off valve and nozzle, handle for operating and condition, condition of cabinet and hose, coupling spanner wrench, fire ax marked with vessel designation and fog applicator. Placard indicating station number posted.

Standard: Hose marked with test date and pressure within previous 12 months, also marked with vessel designation, shut off valve and nozzle handle operates freely, nozzle is clear, cabinet free of corrosion, sound and hinges and latch in serviceable condition, coupling spanner wrench, fire ax and fog applicator present and in serviceable condition, fire ax marked with vessel designation. Placard reading "Fire Station No. 1" posted and legible. \_\_\_\_\_

\_\_\_\_\_  
\_\_\_\_\_  
\_\_\_\_\_

**r. Fire Station No. 2:**

*Condition:* Inspect hose for test date and pressure and vessel designation marking, shut off valve and nozzle, handle for operating and condition, condition of cabinet and hose, coupling spanner wrench, and fog applicator. Placard indicating station number posted.

*Standard:* Hose marked with test date and pressure within previous 12 months also marked with vessel designation, shut off valve and nozzle handle operates freely, nozzle is clear, cabinet free of corrosion, sound and hinges and latch in serviceable condition, coupling spanner wrench, and fog applicator present and in serviceable condition. Placard reading 'Fire Station No. 2' posted and legible. \_\_\_\_\_

\_\_\_\_\_  
\_\_\_\_\_  
\_\_\_\_\_

**s. Ladder:**

*Condition:* Inspect treads and handrails and securements and fasteners for damage and deterioration.

*Standard:* No damage or deterioration which effects serviceability. Securements sound and all fasteners in place. \_\_\_\_\_

\_\_\_\_\_  
\_\_\_\_\_  
\_\_\_\_\_

**t. Fuel Filters/Coalescer:**

*Condition:* Verify serviceability, inspect filters and associated piping and valves for leaks.

*Standard:* Unit is fully operational and filters, associated piping and valves are leak free. \_\_\_\_\_

\_\_\_\_\_  
\_\_\_\_\_  
\_\_\_\_\_  
\_\_\_\_\_

**u. Fuel Transfer Pumps:**

*Condition:* Verify operational condition inspect for leaks, normal pressure.

Standard: Unit operates and maintains pressure without excessive vibration or noise, no leaks from shaft seal or piping or pipe joints and flanges. \_\_\_\_\_

\_\_\_\_\_  
\_\_\_\_\_  
\_\_\_\_\_

**v. Dirty Lube Oil Pump:**

Condition: Verify operational condition, inspect for leaks, normal pressure.

Standard: Unit operates and maintains pressure without excessive vibration or noise, no leaks from shaft seal or piping or pipe joints and flanges. \_\_\_\_\_

\_\_\_\_\_  
\_\_\_\_\_  
\_\_\_\_\_

**w. Fresh Water Pumps (2):**

Condition: Verify operational condition, inspect for leaks, normal pressure.

Standard: Unit operates and maintains pressure without excessive vibration or noise, no leaks from shaft seal or piping or pipe joints and flanges. \_\_\_\_\_

\_\_\_\_\_  
\_\_\_\_\_  
\_\_\_\_\_

**x. Tank Level Indicators (2):**

Condition: Verify operational condition, inspect for leaks in piping.

Standard: Fully operational, and leak free. \_\_\_\_\_

\_\_\_\_\_  
\_\_\_\_\_  
\_\_\_\_\_

**y. Electric Fire Pumps (2):**

*Condition:* Conduct operational test of pumps, inspect output streams from two fire hoses lead out on uppermost deck, activate wash down systems and observe discharge from washdown nozzles. Observe pump pressure with discharge valve closed. Conduct operational test of foam system by discharging foam from pilot house top fire monitors. Inspect fire pumps during tests for excessive vibration or noise. Inspect all fire system piping while under pressure for leaks in piping flanges, valves and fittings. Verify operation of fire pump remote start switches.

*Standard:* Each pump is capable of discharging two streams of water at least 40 feet from hoses connected to stations on the upper deck. Each pump is capable of maintaining 125 psi under closed discharge valve test. Wash down system valves are operational, and system is leak free. All washdown nozzles discharge a uniform spray pattern and quantity of water. Foam system is operational. Fire pumps operate without excessive noise or vibration. Entire fire fighting piping system is leak free. Remote fire pump start stations are operational.

---

---

---

---

---

**z. Bilge and Ballast Pump:**

*Condition:* Verify unit is operational by activating and pumping sea water overboard. Inspect pump and piping system for leaks. Inspect pump for vibration and noise.

*Standard:* Unit is operational pumps a strong stream of water from overboard discharge. Pump and piping system are leak free. Pump operates without excessive vibration or noise. \_\_\_\_\_

---

---

---

---

---

**aa. Sound Powered Telephone:**

*Condition:* Inspect for condition of cabinet, bell and instrument.

*Standard:* Cabinet intact and serviceable, no indication of leakage, instrument and cord and bell present intact and not damaged or deteriorated. \_\_\_\_\_

---

---

---

---

---

**ab. Eye Wash Station:**

*Condition:* Verify operation and inspect tank for level.

*Standard:* Unit is operational, storage tank is full to mark (16 gallon). \_\_\_\_\_  
\_\_\_\_\_  
\_\_\_\_\_  
\_\_\_\_\_

**ac. Dirty Oil Tank:**

*Condition:* Inspect for leaks.

*Standard:* No leaks. \_\_\_\_\_  
\_\_\_\_\_  
\_\_\_\_\_  
\_\_\_\_\_

**ad. Sludge Tank.**

*Condition:* Inspect for leaks.

*Standard:* No leaks. \_\_\_\_\_  
\_\_\_\_\_  
\_\_\_\_\_  
\_\_\_\_\_

**ae. Fire Extinguishers Nos. 3 & 5:**

*Condition:* Inspect for presence, number designation, seal, damage, gage reading, monthly inspections performed.

*Standard:* Present, numbered, seal intact, damage free, gage reading in "normal" range. Log book should indicate monthly inspection. \_\_\_\_\_  
\_\_\_\_\_  
\_\_\_\_\_  
\_\_\_\_\_

**af. Engine Room Bilges:**

*Condition:* Inspect for cleanliness, corrosion, trash and debris.

*Standard:* Bilges are clean, free of corrosion, trash and debris. \_\_\_\_\_

---

---

---

---

**ag. Foam Tank:**

*Condition:* Inspect to determine level of foam in tank, inspect tank for evidence of leaking, verify that foam meets manufacturers specifications.

*Standard:* Foam is at full level in tank, tank is leak free, verify from ships records or log that foam has been tested and approved for continued use within past two years. \_\_\_\_\_

---

---

---

---

**ah. Sea Chest, Sea Valve and Piping:**

*Condition:* Inspect for corrosion, leaks, and freedom of valve operation.

*Standard:* No excessive corrosion, no leaks, sea valve opens and closes freely. \_\_\_\_\_

---

---

---

---

**12.0 Engine Room Control Station.**

**12.1 Forward Bulkhead.**

**a. Intercom:**

*Condition:* Check operation to all stations in send and receive modes, observe lamps, rheostat, controls and selector switch.

*Standard:* Clear effective communication in send and receive modes to all stations from bridge, volume control, lamps, rheostats and selector switches intact and functional. \_\_\_\_\_

---

---

---

---



**b. Engine Room Console:**

*Condition:* Inspect for operational condition, verify lamp and instrument operation.

*Standard:* Operates as designed, lamps light as required, instruments are operational. \_\_\_\_\_  
\_\_\_\_\_  
\_\_\_\_\_  
\_\_\_\_\_

**c. Engine Efficiency Panel:**

*Condition:* Inspect for proper operation by conducting self diagnostic check, check switch indicator lights and lens.

*Standard:* Self diagnostic check reveals no malfunction. All switches, lights and lens intact and operational.  
\_\_\_\_\_  
\_\_\_\_\_  
\_\_\_\_\_

**d. Window:**

*Condition:* Inspect for cracks, damage and degradation of visibility.

*Standard:* No cracks, damage or degradation of visibility. \_\_\_\_\_  
\_\_\_\_\_  
\_\_\_\_\_  
\_\_\_\_\_

**12.2 Stbd Side Bulkhead.**

**a. Sound Powered Telephones (2):**

*Condition:* Inspect for condition of cabinet, bell and instrument.

*Standard:* Cabinet intact and serviceable, no indication of leakage, instrument and cord and bell present intact and not damaged or deteriorated. \_\_\_\_\_  
\_\_\_\_\_  
\_\_\_\_\_  
\_\_\_\_\_

**b. Drinking Fountain:**

*Condition:* Inspect for serviceability, damage, noise and vibration during operation.

*Standard:* Cools water, damage free, no excessive noise or vibration. \_\_\_\_\_  
\_\_\_\_\_  
\_\_\_\_\_  
\_\_\_\_\_

**c. Telephone and Headset:**

*Condition:* Inspect for condition of cabinet, bell and instrument.

*Standard:* Cabinet intact and serviceable, no indication of leakage, instrument and cord and bell present intact and not damaged or deteriorated. \_\_\_\_\_  
\_\_\_\_\_  
\_\_\_\_\_  
\_\_\_\_\_

**d. Air Conditioning Unit.**

*Condition:* Verify operational status.

*Standard:* Operational, blows cool air, no excessive vibration or noise. \_\_\_\_\_  
\_\_\_\_\_  
\_\_\_\_\_  
\_\_\_\_\_

**e. Windows:**

*Condition:* Inspect for cracks, damage and degradation of visibility.

*Standard:* No cracks, damage or degradation of visibility. \_\_\_\_\_  
\_\_\_\_\_  
\_\_\_\_\_  
\_\_\_\_\_

12.3 Port Side

a. Switchboard:

Condition: Inspect for grounds (w/ground lamps) instrument readings, switch operation, meter calibration, verify annual cleaning performed.

Standard: No grounds are indicated, instruments are functional and bear calibration sticker from last OCCM period, switches are functional, no damage present, verify switchboard cleaned within previous 12 months. NOTE: Calibration of switchboard instruments is normally included as part of the OCCM specifications.

Four horizontal lines for notes.

b. Exposure Suit:

Condition: Inspect for tears, cracks, whistle and light, zipper and markings.

Standard: No tears or cracks present, whistle and light attached and serviceable, zipper is lubricated and operates freely, unit marked with vessel designation.

Four horizontal lines for notes.

c. Windows:

Condition: Inspect for cracks, damage and degradation of visibility.

Standard: No cracks, damage or degradation of visibility.

Four horizontal lines for notes.

13.0 Machine Shop.

a. Watertight Door:

Condition: Inspect gaskets, operation, hinges dogs and hold back hooks.

*Standard:* Gasket in good condition undamaged, flexible, fills channel, dogs all operational, hinges undamaged and permit free movement. Hold back hook and eye present and serviceable. \_\_\_\_\_

---

---

---

---

---

**b. Space Heater:**

*Condition:* Inspect for operation, noise and vibration.

*Standard:* Operates, heats air, no excessive noise or vibration. \_\_\_\_\_

---

---

---

---

**c. Ventilation System:**

*Condition:* Verify operation of fan motor, inspect ducting for damage, corrosion and deterioration.

*Standard:* Vent fan operational, fan and ducting free of damage corrosion and deterioration. \_\_\_\_\_

---

---

---

---

**d. Welder:**

*Condition:* Verify operational condition, inspect for presence of "No Welding in Compartment" placard.

*Standard:* Welder is operational, placard is posted. \_\_\_\_\_

---

---

---

---

**e. Gas Monitor:**

*Condition:* Verify that gas monitoring meter and accessories are on hand, secured in locker in compartment.

Standard: Meter on hand in locker. \_\_\_\_\_  
\_\_\_\_\_  
\_\_\_\_\_  
\_\_\_\_\_

**f. Heat Sensor Sending Unit:**

Condition: Check operation of heat sensing unit.

Standard: Heat sensor activates alarm when heat is applied. \_\_\_\_\_  
\_\_\_\_\_  
\_\_\_\_\_  
\_\_\_\_\_

**14.0 Store Room (Stbd Side Forward Engine Room).**

**a. Watertight Door.**

Condition: Inspect gaskets, operation, hinges dogs and hold back hooks.

Standard: Gasket in good condition undamaged, flexible, fills channel, dogs all operational, hinges undamaged and permit free movement. Hold back hook and eye present and serviceable. \_\_\_\_\_  
\_\_\_\_\_  
\_\_\_\_\_  
\_\_\_\_\_

**b. Stores:**

Condition: Inspect for stowed material properly secured, no unauthorized hazardous material present.

Standard: Stowed material secure against movement in seaway, no unauthorized hazardous material present. \_\_\_\_\_  
\_\_\_\_\_  
\_\_\_\_\_  
\_\_\_\_\_

**c. Space Heater:**

Condition: Inspect for operation, noise and vibration.

Standard: Operates, heats air, no excessive noise or vibration. \_\_\_\_\_  
\_\_\_\_\_  
\_\_\_\_\_  
\_\_\_\_\_

**d. Heat Sensor Sending Unit:**

Condition: Check operation of heat sensing unit.

Standard: Heat sensor activates alarm when heat is applied. \_\_\_\_\_  
\_\_\_\_\_  
\_\_\_\_\_  
\_\_\_\_\_

**15.0 Machinery Tunnel.**

**a. Hydraulic Oil Storage Tank and Indicator:**

Condition: Inspect for leaks, verify that level indicator is operational.

Standard: Tank shows no evidence of leaks, indicator is operational. \_\_\_\_\_  
\_\_\_\_\_  
\_\_\_\_\_  
\_\_\_\_\_

**b. Space Heater:**

Condition: Inspect for operation, noise and vibration.

Standard: Operates, heats air, no excessive noise or vibration. \_\_\_\_\_  
\_\_\_\_\_  
\_\_\_\_\_  
\_\_\_\_\_

**c. Fire Station No. 8:**

Condition: Inspect hose for test date and pressure and vessel designation marking, shut off valve and nozzle, handle for operating and condition, condition of cabinet and hose. coupling spanner wrench, and fog applicator. Placard indicating station number posted.

*Standard:* Hose marked with test date within previous 12 months, also marked with vessel designation, shut off valve and nozzle handle operates freely, nozzle is clear. cabinet free of corrosion. sound and hinges and latch in serviceable condition, coupling spanner wrench and fog applicator present and in serviceable condition. Placard reading "Fire Station No. 8" posted legible. \_\_\_\_\_

\_\_\_\_\_  
\_\_\_\_\_  
\_\_\_\_\_

**d. Stowage of Gear:**

*Condition:* Inspect for stowed material properly secured, no unauthorized hazardous material present.

*Standard:* Stowed material secure against movement in seaway, no unauthorized hazardous material present.

\_\_\_\_\_  
\_\_\_\_\_  
\_\_\_\_\_

**e. Power Panels:**

*Condition:* Inspect for damage, verify operational condition.

*Standard:* No damage. panels are operational. \_\_\_\_\_

\_\_\_\_\_  
\_\_\_\_\_  
\_\_\_\_\_

**f. Sewage Storage Tank and Pump:**

*Condition:* Inspect for leaks in tank. pump and associated piping, verify operational conditions and that aerator regulator valves are engaged.

*Standard:* No leaks, pump operates, aerator regular valves engaged. \_\_\_\_\_

\_\_\_\_\_  
\_\_\_\_\_  
\_\_\_\_\_

**g. Watertight Doors, Fore and Aft:**

*Condition:* Inspect gaskets, operation, hinges dogs and hold back hooks.

*Standard:* Gasket in good condition undamaged, flexible, fills channel, dogs all operational, hinges undamaged and permit free movement. Hold back hook and eye present and serviceable. \_\_\_\_\_

\_\_\_\_\_  
\_\_\_\_\_  
\_\_\_\_\_

**h. Butterfly Valve:**

*Condition:* Verify operation of butterfly valve.

*Standard:* Valve operates freely and seals properly. \_\_\_\_\_

\_\_\_\_\_  
\_\_\_\_\_  
\_\_\_\_\_

**i. Foam Station No. 1:**

*Condition:* Check for hose test date and pressure and vessel designation marking, nozzle present and in good condition, control valve operation, hose locker preservation and damage, coupling spanner wrench present, marked Foam Station No. 1.

*Standard:* Hose tested and marked with date and pressure within prior 12 months, also marked with vessel designation. Nozzle present and undamaged, control valve operates freely, hose locker in good condition, undamaged and preserved, spanner wrench at station, station legibly marked "Foam Station No. 1."

\_\_\_\_\_  
\_\_\_\_\_  
\_\_\_\_\_

**j. Air Compressors and Receivers (If located in tunnel):**

*Condition:* Operational test, check capacity, check for inspection tags on reservoirs and relief valves, check oil pressure when warmed up.



Standard: Units are operational. capable of pumping 200 gal reservoir to 175 psi from empty in less than 12 minutes. Test tags indicate test at previous OCCM (313 psi for tanks, 220 psi for relief valves, oil pressure 18-20 psi when warmed up. NOTE: OCCM specification will normally provide for hydrostatic test of reservoir and setting of relief valves. \_\_\_\_\_  
\_\_\_\_\_  
\_\_\_\_\_  
\_\_\_\_\_

**k. Water Heater and Associated Piping:**

Condition: Inspect hot water tank and piping for leaks, verify operational condition.

Standard: Tank and associated piping are leak free and operational. \_\_\_\_\_  
\_\_\_\_\_  
\_\_\_\_\_  
\_\_\_\_\_

**l. Bilges:**

Condition: Inspect for cleanliness, corrosion, trash and debris.

Standard: Bilges are clean, free of corrosion, trash and debris. \_\_\_\_\_  
\_\_\_\_\_  
\_\_\_\_\_  
\_\_\_\_\_

**16.0 Bow Thruster Compartment.**

**a. Day Tank:**

Condition: Inspect for leaks, verify that level indicator is operational.

Standard: Tank shows no evidence of leaks, indicator is operational. \_\_\_\_\_  
\_\_\_\_\_  
\_\_\_\_\_  
\_\_\_\_\_

**b. Battery Box and Batters:**

*Condition:* Inspect for corrosion and condition of connections and cables, missing caps electrolyte level, condition of box and securing devices, no smoking placard.

*Standard:* Terminals corrosion free, cables undamaged, all caps present, electrolyte above plates, box and securing devices sound and corrosion free. No smoking placard present. \_\_\_\_\_

---

---

---

---

**c. Battery Charger:**

*Condition:* Verify operational capability including ammeter, inspect for damage and completeness.

*Standard:* Charger is operational, ammeter functions, unit is complete and undamaged. \_\_\_\_\_

---

---

---

---

**d. Sound Powered Telephone:**

*Condition:* Inspect for condition of cabinet, bell and instrument.

*Standard:* Cabinet intact and serviceable, no indication of leakage. instrument and cord and bell present intact and not damaged or deteriorated. \_\_\_\_\_

---

---

---

---

**e. Telephone Headset:**

*Condition:* Inspect for completeness, condition of enclosure, hatch, seal, hinges, condition of cords and station selector switch.

*Standard:* All components present, enclosure latch operates, hinges free, watertight seal sound, cords and wiring not damaged or deteriorated, selector switch turns freely. \_\_\_\_\_

---

---

---

---

**f. Power Panels:**

*Condition:* Inspect for damage, verify operational condition.

*Standard:* No damage, panels are operational. \_\_\_\_\_  
\_\_\_\_\_  
\_\_\_\_\_  
\_\_\_\_\_

**g. Space Heater:**

*Condition:* Inspect for operation, noise and vibration.

*Standard:* Operates, heats air, no excessive noise or vibration. \_\_\_\_\_  
\_\_\_\_\_  
\_\_\_\_\_  
\_\_\_\_\_

**h. Escape Hatch Ladder:**

*Condition:* Inspect to see that ladder is in place, properly secured, unobstructed and functional.

*Standard:* Ladder is present, properly secured and unobstructed and functional. \_\_\_\_\_  
\_\_\_\_\_  
\_\_\_\_\_  
\_\_\_\_\_

**i. Bow Thruster Engine, Bow Thruster, Controls, Fire Pump, and Clutch:**

*Condition:* Test operate at dock or underway. Inspect for leaks in lube oil, fuel oil, water and exhaust systems, check temperature and pressures for normal readings. Check that engine can be started and controlled from both pilot house and local control station. Check for vibration and unusual noise. Exercise bowthruster waterjet from both control stations and observe direction indicators in compartment and pilot house. Disengage waterjet and engage fire pump clutch. Check capacity of fire pump. Check log for accomplishment of P/M services as applicable.

- Adjust valves and injectors
- Check/replace hoses
- Check/tighten turbo-charger mounting bolts

- Check safety controls
- Remove and clean magnetic pick up
- Check coolant heater for corrosion
- Drain and refill waterjet hydraulic system
- Drain and refill waterjet lube oil system
- Lubricate waterjet drive shaft

36 Month

- Replace injectors (as needed)
- Replace fuel pump (as needed)
- Check turbo-charger clearances
- Replace coolant pump and idler pulley assembly (as needed)
- Replace engine sea water pump (as needed)
- Drain, flush and replace coolant
- Check crankshaft end play

*Standard:* No leaks in lube oil, fuel oil, water or exhaust systems. After engine is warmed up engine oil pressure should be at least 17 psi at 1800 RPM and pressure should be approximately 50 psi, water temperature less than 215° F, normal 160-200° F. Oil temperature less than 225° F. Engine can be started and controlled from both pilot house and local control. Engine does not vibrate excessively. Bowthruster responds smoothly to both control stations and direction indicators accurately indicate direction of thrust. Fire pump clutch engage and disengages pump. Fire pump capable of maintaining a pressure of 125 psi in closed discharge valve test and capable of spraying streams of at least 40 ft from 2 fire hoses at stations on the uppermost deck. Log indicates accomplishment of all required P/M services as applicable (annual services at interim inspection, annual services and 36 month services at Pre-OCCM inspection). \_\_\_\_\_

---



---



---



---

**j. Intercom:**

*Condition:* Inspect visually for damage, and completeness.

*Standard:* No damage, all components intact. \_\_\_\_\_

---



---



---



---

**k. Heater:**

*Condition:* Inspect for damage and verify operational condition.

*Standard:* Unit is undamaged and operational. \_\_\_\_\_  
\_\_\_\_\_  
\_\_\_\_\_  
\_\_\_\_\_

**l. Vent Fan:**

*Condition:* Inspect for damage and verify operation condition.

*Standard:* Fan is undamaged, operates without excessive vibration or noise.  
\_\_\_\_\_  
\_\_\_\_\_  
\_\_\_\_\_

**m. Hydraulic Power Unit, Port Anchor Winch:**

*Condition:* Inspect when conducting anchor windlass inspection paragraph 9.2-c. Inspect for leaks in pump and associated piping, excessive vibration and unusual noise. Check log for verification of accomplishment of P/M of bi-annual hydraulic system draining and refilling.

*Standard:* No leaks, excessive vibration or unusual noise, hydraulic system draining and refilling accomplished in previous 24 month period. \_\_\_\_\_  
\_\_\_\_\_  
\_\_\_\_\_  
\_\_\_\_\_

**n. Fire Extinguisher No. 9:**

*Condition:* Inspect for presence, number designation, seal, damage, gage reading. monthly inspections performed.

*Standard:* Present, numbered, seal intact, damage free, gage reading in "normal" range. Log book should indicate monthly inspection. \_\_\_\_\_  
\_\_\_\_\_  
\_\_\_\_\_  
\_\_\_\_\_

**o. Chain Locker and Access Panels:**

*Condition:* Remove access panels, inspect chain lockers for condition of preservation and corrosion, inspect access panel gaskets and fasteners.

*Standard:* Chain locker preservation in good condition, no excessive corrosion present, access panels gaskets and fasteners in serviceable condition. \_\_\_\_\_

---

---

---

---

**p. Bilges:**

*Condition:* Inspect for cleanliness, corrosion, trash and debris.

*Standard:* Bilges are clean, free of corrosion, trash and debris. \_\_\_\_\_

---

---

---

---

**q. Sea Chest, Sea Valve and Piping:**

*Condition:* Inspect for corrosion, leaks, and freedom of valve operation.

*Standard:* No excessive corrosion, no leaks, sea valve opens and closes freely. \_\_\_\_\_

---

---

---

---

**17.0 Steering Gear Compartment.**

**a. Intercom:**

*Condition:* Inspect visually for damage, and completeness.

*Standard:* No damage, all components intact. \_\_\_\_\_

---

---

---

---

**b. Sound Powered Telephone:**

*Condition:* Inspect for condition of cabinet, bell and instrument.

*Standard:* Cabinet intact and serviceable, no indication of leakage, instrument and cord and bell present intact and not damaged or deteriorated. \_\_\_\_\_

\_\_\_\_\_  
\_\_\_\_\_  
\_\_\_\_\_

**c. Space Heater:**

*Condition:* Inspect for damage, operational condition, excessive vibration or noise.

*Standard:* Heater is undamaged, operational (blows hot air) free of excessive vibration or noise. \_\_\_\_\_

\_\_\_\_\_  
\_\_\_\_\_  
\_\_\_\_\_

**d. Gyro Repeater:**

*Condition:* Inspect for tracking with master gyro, free in swivel, operation of lamp and rheostat, condition of mount and fasteners.

*Standard:* Reads same heading as master gyro, free in swivel, lamp lights and intensity varies with rheostat setting, mount and fasteners are sound and all fasteners are present. \_\_\_\_\_

\_\_\_\_\_  
\_\_\_\_\_  
\_\_\_\_\_

**e. Manual Hydraulic Steering Pump.**

*Condition:* Line up valves for manual steering, operate manual steering pump in both directions to demonstrate operational capability.

*Standard:* Rudder responds when manual steering pump is operated. \_\_\_\_\_

\_\_\_\_\_  
\_\_\_\_\_  
\_\_\_\_\_

**f. Steering Gear Power Unit, Controls, Linkage and Mechanical Components:**

*Condition:* Operational test using one pump and then the other with either pump test in both non follow up and full follow up and helm control and jog control modes. Inspect pumps, piping, rams and seals for leakage of hydraulic fluid. Inspect rudder stocks for leakage. Inspect linkage for damage excessive clearances (wear) and proper operation. Check rudder angle indicators against actual rudder position. Check log for accomplishment of annual P/M services of checking foundation bolts and fasteners and hydraulic oil change and filter/strainer replacement/cleaning.

*Standard:* Hydraulic components are leak free. Rudder stocks are leak free. Linkage is damage free, intact, not worn excessively and operates rudders smoothly in response to all controls. All controls are fully functional. Rudder angle indicators track rudder movements. Log indicates P/M services of hydraulic oil change and filter/strainer servicing has been accomplished.

---

---

---

---

**g. Stern Anchor Winch Power Unit:**

*Condition:* Inspect when conducting stern anchor winch inspection paragraph 4.0 e. Inspect for leaks in pump and associated piping, excessive vibration and unusual noise. Verify accomplishment of draining and refilling hydraulic system and cleaning reservoirs and strainers.

*Standard:* No leaks, excessive vibration or unusual noise, hydraulic system servicing accomplished within previous 12 month period.

---

---

---

---

**h. Vent Fan:**

*Condition:* Verify operational condition, check for excessive vibration or unusual noise, and corrosion.



Standard: Operational, free of excessive vibration or unusual noise, no excessive corrosion. \_\_\_\_\_

\_\_\_\_\_  
\_\_\_\_\_  
\_\_\_\_\_  
\_\_\_\_\_

**i. Fire Extinguishers (2) No's 1 and 2:**

Condition: Inspect for presence, number designation, seal, damage, gage reading, monthly inspections performed.

Standard: Present, numbered, seal intact, damage free, gage reading in "normal" range, log book should indicate monthly inspection. \_\_\_\_\_

\_\_\_\_\_  
\_\_\_\_\_  
\_\_\_\_\_

**j. Steering Gear Operating Instruction:**

Condition: Inspect to verify operating instructions are posted and legible.

Standard: Operating Instructions are posted and legible. \_\_\_\_\_

\_\_\_\_\_  
\_\_\_\_\_  
\_\_\_\_\_

**k. Escape Hatch (2):**

Condition: Verify free and functional operation of escape hatch, operating gear and hinges movement, gasket condition, hold back hook and eye, inspect ladder for serviceability and obstruction.

Standard: Hatch and securing gear operate freely, gasket is soft and fills cavity, hold back hook and eye present and functional, ladder is completely serviceable and properly secured and unobstructed. \_\_\_\_\_

\_\_\_\_\_  
\_\_\_\_\_  
\_\_\_\_\_  
\_\_\_\_\_

**I. Bilges:**

*Condition:* Inspect for cleanliness, corrosion, trash and debris.

*Standard:* Bilges are clean, free of corrosion and oil, trash and debris.

---

---

---

**m. Rudder Post and Packing:**

*Condition:* Inspect for damages and abnormal wear patterns. Inspect for leaking packing..

*Standard:* Repair all damages. Install new packing if worn. \_\_\_\_\_

---

---

---

---

---

\*U.S. GOVERNMENT PRINTING OFFICE: 1997 - 550-024/60084

INDEX

SUBJECT	Page
.50 Caliber gun mount description and location.....	1-10
01 Level description.....	1-5
01 Level external features .....	1-12
02 Level description.....	1-5
02 Level external features .....	1-10
120V Distribution Transformer description and location .....	1-57
16-Ton 240V Compressor, (PMCS) .....	2-239
24V Battery Charger description and location .....	1-36
24V Panel description and location.....	1-33
24V Panel description and location.....	1-36
35 foot whip antenna description and location.....	1-12
500 Watt XENON Searchlight	
Controls and Indicators .....	2-32
Operation.....	2-541
Directing Beam .....	2-542
Focusing Beam from Searchlight Drum .....	2-544
Focusing Beam In Pilothouse.....	2-542
Lighting Lamp .....	2-542
Shutdown.....	2-544

A

Acetylene torch description and location.....	1-64
Additional Authorization List.....	C-1
Adjustable flood light description and location.....	1-10
Aft - defined.....	iv
Air Compressor and Gauges, Controls and Indicators.....	2-89
Air Compressors description and location .....	1-52
Air Conditioning and Emergency Generator Room description and location.....	1-46
Air conditioning unit description and location .....	1-60
Air Dryer description and location .....	1-52
Air isolation valve description and location .....	1-64
Air pressure gauge description and location.....	1-21
Air Receivers description and location .....	1-54
Air Start Main Generator Operation .....	2-366
Airports, Fixed Lights, and Windows Principles of Operation .....	1-168
Alarm Bell description and location .....	1-26
Alarm Panel description and location.....	1-26
Ammo Locker description and location .....	1-33
AN/VRC-46 description and location.....	1-30
Anchor windlass hydraulic power unit description and location.....	1-67
Anchor windlass motor controller description and location.....	1-67
Antenna arrangement description.....	1-8
Antenna artificial assembly description and location .....	1-28
Antenna coupler description and location.....	1-12
Antenna coupler description and location.....	1-28
Arc Welder .....	see electric welding machine
Arms Control Room description and location .....	1-45
Arms control room sprinkler valve description and location .....	1-30

INDEX - CONT

SUBJECT	Page
<b>A - Cont</b>	
Automatic Direction Finder description and location.....	1-28
Automatic Power Switch, Controls and Indicators .....	2-34
Automatic Power Switch description and location .....	1-28
Autopilot Control Panel, Controls and Indicators.....	2-12
Autopilot description and location .....	1-21
Autopilot Principles of Operation.....	1-104
Auxiliary Machinery Motor Control Center	
Controls and Indicators .....	2-76
PMCS .....	2-277
Shutdown.....	2-601
Auxiliary Machinery Motor Control Center description and location .....	1-56
<b>B</b>	
Basic Issue Items.....	B-1
Batteries PMCS.....	2-263
Battery Box description and location.....	1-67
Battery Box PMCS.....	2-278
Battery Charger description and location.....	1-67
Battery Charger description and location.....	1-46
Battery charger description and location .....	1-56
Battery Charger for Comma Batteries, PMCS .....	2-230
Battery Charger - Hand Held description location.....	1-36
Battery Charger PMCS .....	2-264, 2-278
Battery Storage Box description and location.....	1-56
Before You Operate This Equipment .....	2-284
Below main deck description.....	1-48 to 1-71
Bench Grinder	
Controls and Indicators .....	2-159
Operation.....	2-534
PMCS .....	2-276
Bench grinder description and location .....	1-60
Bilge/Ballast and Firemain Piping System Principles of Operation .....	1-117
Bilge/Ballast Piping System Principles of Operation.....	1-117
Fire Main and Foam Piping System Principles of Operation.....	1-117
Bilge/Ballast Piping System	
Ballast Operation .....	2-447
Bilge/Ballast Pump PMCS .....	2-269
Bilge Pumping Operation .....	2-454
Deballast Operation .....	2-453
Bilge/Ballast pump controller description and location.....	1-56
Bilge/Ballast Pump description and location.....	1-56
Binocular storage box description and location .....	1-30
Blinker Light Key description and location.....	1-21
Boatswain Stowage Locker description and location.....	1-48
Boatswains Stowage internal features description and location.....	1-48
Bow Anchor .....	1-48
Bow Anchor Windlass Controller PMCS.....	2-245, 2-246

INDEX - CONT

SUBJECT	Page
<b>B - Cont</b>	
Bow Anchor Windlass Hydraulic Power Pack Assembly.....	2-249
Bow Anchor Windlass	
Controls and Indicators .....	2-132
Operation.....	2-482
Hauling In Anchor.....	2-502
Lowering Anchor By Paying Out Chain.....	2-496
Lowering Anchor By Replacing Handwheel Brake.....	2-501
Start-Up .....	2-496
Warping Head Operation.....	2-503
PMCS .....	2-244, 2-245
Bow anchor description.....	1-6
Bow anchor windlass controller description and location.....	1-18
Bow anchor windlass description and location.....	1-18
Bow Anchor Windlass Hydraulic Unit description and location .....	1-48
Bow Anchor Windlass System Principles of Operation.....	1-100
Bow Ramp	
Bow Ramp Locking Assembly Controls and Indicators.....	2-140
Bow Ramp System Controls and Indicators.....	2-136
Control Panel Controls and Indicators.....	2-19
Controls PMCS .....	2-244
Hydraulic Power Pack Assembly PMCS.....	2-248
Manual Operation .....	2-663
After Manual Operation .....	2-668
Lower Bow Ramp.....	2-666
Preparation for Operation.....	2-663
Raise Bow Ramp.....	2-668
Operation.....	2-504
Lower Bow Ramp.....	2-505
Raise Bow Ramp .....	2-509
Start-Up .....	2-504
PMCS .....	2-248
Bow ramp control panel description and location .....	1-21
Bow ramp controls description and location .....	1-18
Bow ramp description .....	1-7
Bow Ramp Motor Controller description and location.....	1-48
Bow Ramp System Principles of Operation.....	1-100
Hydraulic Power Pack Principles of Operation .....	1-100
Winch Assembly Principles of Operation.....	1-100
Ramp Lifting Assemblies Principles of Operation.....	1-101
Bow Ramp Winch description and location .....	1-48
Bow Ramp Winch Hydraulic Unit description and location .....	1-48
Bow windlass/bowthruuster motor controller description and location.....	1-64
Bowthruuster	
Bowthruuster Day Tank PMCS.....	2-278
Bowthruuster/Emergency Fire Pump Throttle Control	
Controls and Indicators.....	2-4
Bowthruuster Engine Control Panel Controls and Indicators.....	2-126
Bowthruuster Engine PMCS.....	2-279
Bowthruuster Engine Tachometer Controls and Indicators.....	2-4

INDEX - CONT

SUBJECT	Page
<b>B - Cont</b>	
Bowthruster System Operation .....	2-433
Bowthruster Diesel Engine Operation .....	2-433
Waterjet Operation .....	2-438
Waterjet Shutdown .....	2-442
Bowthruster Waterjet	
Control Panel Controls and Indicators .....	2-14
Waterjet PMCS .....	2-281
Waterjet Controls and Indicators .....	2-125
Bowthruster compartment description and location .....	1-67
Bowthruster Compartment Soft Patch description and location .....	1-18
Bowthruster control panel description and location .....	1-21
Bowthruster day tank description and location .....	1-67
Bowthruster day tank shut off description and location .....	1-64
Bowthruster engine description and location .....	1-21
Bowthruster/fire pump throttle/clutch description and location .....	1-21
Bowthruster Waterjet Set description and location .....	1-67
Bowthruster Water-et System Principles of Operation .....	1-100
Bridge Console Panel Controls and Indicators .....	2-20
Bridge Console Panel description and location .....	1-23
<b>C</b>	
Cabinet description and location .....	1-28
Cargo deck description .....	1-7
Cargo description .....	1-1
Caustic and corrosive chemical warning .....	Inside front cover
CECOM Cross Reference List .....	1-2
Chain stopper description and location .....	1-18
Chain Stopper PMCS .....	1-28
Chart storage description and location .....	1-28
Chart table description and location .....	1-28
Chart table description and location description and location .....	1-30
Chief Engineers stateroom description and location .....	1-36
Chronometer storage cabinet description and location .....	1-28
Clearview Screen Controls and Indicators .....	2-40
Clinometer (HEEL) description and location .....	1-26
Clinometer (TRIM) description and location .....	1-12
Closed chock description and location .....	1-18
Clothes Dryer Panel Control and Indicators .....	2-164
Clothes Washer Panel Controls and Indicators .....	2-165
Coffee pot description and location .....	1-36
Coffee pot description and location .....	1-60
Commissary Equipment	
Dishwater Operation .....	2-551
Electric Griddle Operation .....	2-553
Electric Mixer Operation .....	2-559

INDEX - CONT

SUBJECT	Page
<b>C - Cont</b>	
Electric Range Operation.....	2-556
Freezer Operation.....	2-561
Fry Kettle Operation.....	2-569
Gaylord Control Cabinet Operation.....	2-554
Marine Coffee Pot Operation.....	2-568
Meat Slicer Operation.....	2-560
Microwave Oven Operation.....	2-562
Milk Dispenser Operation.....	2-562
Post-Mix Dispenser Operation.....	2-565
Refrigerator Operation.....	2-561
Trash Compactor Operation.....	2-565
Commissary Equipment Principles of Operation.....	1-101
Communications Batteries description and location.....	1-10
Communications Batteries PMCS.....	2-226
Communications Modem description and location.....	1-33
Compass Repeater PMCS.....	2-252
Components of End Items.....	B-1
Compressed Air Piping System	
Operation.....	2-324
Shutdown.....	2-604
PMCS.....	2-254
Compressed Air Piping System Principles of Operation.....	1-154
Compressed air warning.....	Inside front cover
Control Air Transfer Valve Controls and Indicators.....	2-4
Control air valve description and location.....	1-21
Control and Monitoring System Principles of Operation.....	1-90
Engine Room Console Principles of Operation.....	1-91
Pilothouse Console Principles of Operation.....	1-91
Dual Station Throttle Control Principles of Operation.....	1-91
Machinery Plant Monitoring System Principles of Operation.....	1-91
Engine Order Telegraph Principles of Operation.....	1-92
Steering Control Panel Principles of Operation.....	1-94
Bowthruster Control Principles of Operation.....	1-94
Fire Detection Principles of Operation.....	1-94
Bow Ramp Control Principles of Operation.....	1-95
Dead Man Alarm Principles of Operation.....	1-95
Engineer's Assistance Needed Principles of Operation.....	1-95
Control Unit - URC-80 description and location.....	1-23
Countermeasure washdown system description and location.....	1-9
Craft Cleanliness PMCS.....	2-213
Crews head exhaust description and location.....	1-12

**D**

Damage Control Board description and location.....	1-26
Damage Control Locker description and location.....	1-38
Damage control lumber rack description and location.....	1-64
Data, Equipment.....	1-69
dc Converter description and location.....	1-28

INDEX - CONT

SUBJECT	Page
<b>D - Cont</b>	
dc Power Supply description and location.....	1-28
Deballasting Using Fire Pumps.....	2-654
Deck floodlight description and location.....	1-10
Depth finder digital display description and location.....	1-23
Depth Finder Digital Display description and location.....	1-21
Devils claw description and location.....	1-18
Dirty Lube all discharge point description and location.....	1-14
Dirty Lube On Pump PMCS .....	2-263
Dirty Lube Oil pump description and location .....	1-54
Dishwasher	
Controls and Indicators .....	2-166
Operation.....	2-551
PMCS .....	2-237
Distress Signal Receiver description and location.....	1-26
Doors, Hatches, and Scuttles Principles of Operation.....	1-168
Doors, Hatches, Covers, and Scuttles PMCS.....	2-214
Double Bitt description and location.....	1-18
Double Bitt description and location.....	1-12

**E**

EL102 description and location.....	1-33
Electric fire pumps description and location .....	1-56
Electric Griddle	
Controls and Indicators .....	2-167
Operation.....	2-551
Electric Mixer	
Controls and Indicators .....	2-176
Operation.....	2-556
Electric Welding Machine	
Controls and Indicators .....	2-160
Operation.....	2-536
PMCS .....	2-276
Electrical hazards warning.....	Inside front cover
Electrical System Principles of Operation .....	1-108
Electrohydraulic Steering System PMCS .....	2-252
Electromagnetic radiation warning.....	Inside front cover
Emergency Fire Pump Controls and Indicators .....	2-182
Emergency Fire Pump description and location .....	1-67
Emergency fuel shutdown for day tanks description and location.....	1-14
Emergency Generator	
Batteries PMCS .....	2-234
Day Tank PMCS .....	2-240
Diesel Engine Control Panel Control and Indicators.....	2-122
Operation.....	2-641
Shutdown.....	2-604
Emergency generator battery box description and location.....	1-14
Emergency Generator Day Tank description and location.....	1-46
Emergency Generator description and location.....	1-46



## INDEX – CONT.

SUBJECT	Page
<b>E – Cont.</b>	
Emergency Generator Fuel Oil Day Tank Vent Description and Location .....	1-12
Emergency Lifeboat Transceiver Description and Location .....	1-25
Emergency Power Generation	
Emergency Equipment Available .....	2-641
Operate Main Switchboard on Emergency Power .....	2-642
Operation .....	2-641
Reset Emergency Generator .....	2-642
Emergency Switchboard	
PMCS .....	2-242
Shutdown .....	2-604
Emergency Switchboard	
PMCS .....	2-242
Shutdown .....	2-604
Emergency Switchboard Description and Location .....	1-46
Engine Access Soft Patch Description and Location .....	1-16
Engine Efficiency Panel Controls and Indicators .....	2-58
Engine Efficiency Panel Description and Location .....	1-57
Engine Efficiency Panel Description and Location .....	1-57
Engine Exhaust Fan Description and Location .....	1-12
Engine Order Telegraph	
Controls and Indicators .....	2-16
Operation .....	2-521
PMCS .....	2-229, 2-275
Engine Order Telegraph Description and Location .....	1-21
Engine Room and Interior Hull PMCS .....	2-253
Engine Room Console	
Panel Controls and Indicators .....	2-54
PMCS .....	2-275
Controls and Indicators .....	2-50
Engine Room Console Description and Location .....	1-57
Engine Room Equipment Removal Soft Patch Description and Location .....	1-14
Engine Room Escape Hatch Description and Location .....	1-16
Engine Room HALON 1301 Fire Suppression System PMCS .....	2-240
Engine Room HALON Release Description and Location .....	1-16
Engine Room Supply Fan Description and Location .....	1-14
Engine Room Ventilation Motor Control Center Controls and Indicators .....	2-86
Engineer Assistance Needed Alarm Location .....	1-42
Ensign Staff Description and Location .....	1-14
Environmental Control System Principles of Operation	
Pilothouse Principles of Operation .....	1-77
Accommodation Deck (01 Level) Principles of Operation .....	1-79
Main Deck (Aft) Principles of Operation .....	1-79
Main Deck (Forward) Principles of Operation .....	1-83
Below Main Deck (Aft) Principles of Operation .....	1-83
Below Main Deck (Forward) Principles of Operation .....	1-86
Heating Principles of Operation .....	1-86
Ventilation Principles of Operation .....	1-89
Air Conditioning Principles of Operation .....	1-89
EOS Air Handling Unit PMCS .....	2-275
EOS Description and Location .....	1-57
EOS Escape Scuttle Description and Location .....	1-39
EP103 Description and Location .....	1-33

INDEX – CONT.

SUBJECT	Page
<b>E – Cont.</b>	
Equipment Condition Prior to Getting Underway .....	2-589
Escape Hatch Description and Location .....	1-18
Exhaust From Steering Compartment Description and Location.....	1-14
Exhaust Ventilation/Escape Hatch Description and Location .....	1-69
Expendable/Durable Supplies and Materials List .....	D-1
External Features .....	1-6 to 1-19
External Hull (Forward of Superstructure Above Waterline) PMCS .....	2-243
External Hull PMCS .....	2-235
<b>F</b>	
Facsimile Recorder-Reproducer Description and Location .....	1-30
Fairlead Roller Description and Location .....	1-18
Fairlead Roller PMCS .....	2-244, 2-245
File Cabinet Description and Location .....	1-57
Final Shutdown .....	2-604
Fire/Airflow Damper Operation .....	2-319
Fire Alarm Bell Description and Location.....	1-26, 1-57
Fire Detection System Principles of Operation .....	1-95
Fire Extinguisher Description and Location .....	1-30, 1-52, 1-60
Fire Fighting System Principles of Operation.....	1-102
FM-200 Fire Suppression System Principles of Operation.....	2-721
HALON 1301 Fire Suppression System Principles of Operation.....	1-102
Countermeasure Washdown System Principles of Operation.....	1-104
Dry Chemical Extinguishers Principles of Operation .....	1-102
Fire Monitors Principles of Operation.....	1-102
Fire Stations Principles of Operation .....	1-102
Foam Proportioners Principles of Operation.....	1-102
Oxygen Breathing Apparatus Principles of Operation .....	1-104
Fire Main and Foam Piping System	
Fire Main and Foam Piping System Shutdown.....	2-604
Fire Main and Foam System Operation .....	2-305
Fire Main Activation.....	2-305
Fire Monitor Operation .....	2-322
Fire Monitor Shutdown.....	2-323
Fire Station Operation .....	2-319
Fire Station Shutdown.....	2-321
Foam Station Shutdown.....	2-323
Foam System Activation .....	2-321
Foam System Operation .....	2-322
Fire Pull Box PMCS .....	2-213
Fire Pumps PMCS .....	2-263
Fire Station and Foam Station PMCS.....	2-213
Firefighting System Operation With Emergency Fire Pump .....	2-685
Fire Main Discharge Gauge Description and Location .....	1-69
Fire Main Suction Gauge Description and Location .....	1-69
Fire Monitor Description and Location .....	1-12

INDEX - CONT

SUBJECT	Page
<b>F - Cont</b>	
Fire pull box description and location.....	1-16
Fire Pull Box description and location.....	1-46
Fire pull box description and location.....	1-64
Fire pull box description and location.....	1-67
Fire Pull Box description and location.....	1-50
Fire Pull Box location.....	1-42
Fire Pump Controllers description and location.....	1-56
Fire Pump description and location.....	1-67
Fire pump gauges description and location.....	1-56
Fire Pump Motor Switch description and location.....	1-56
Fire station description and location.....	1-64
Fire Station No. 1 description and location.....	1-54
Fire Station No. 2 description and location.....	1-54
Fire station No. 3 description and location.....	1-14
Fire Station No. 6 description and location.....	1-18
Fire station number 4 description and location.....	1-16
Fire suppressant hazards warning.....	Inside front cover
Firestation description and location.....	1-10
First Aid and Medical Supplies PMCS.....	2-238
Flammables Locker description and location.....	1-48
Flammable liquid and combustible vapor warning.....	Inside front cover
Floodlight description and location.....	1-14
Foam Educators description and location.....	1-56
Foam Fire Station No. 1 description and location.....	1-56
Foam station No. 1 description and location.....	1-10
Fog horn power supply description and location.....	1-33
Fog horn switch description and location.....	1-23
Fog Signal controller description and location.....	1-33
Fog Signal timer description and location.....	1-33
Follow-up transmitter and linkage description and location.....	1-50
Forecastle deck description.....	1-5
Forecastle deck external features description and location.....	1-18
Foremast description.....	1-7
Foremast description and location.....	1-18
Forward Deck Machinery Motor Control Center controls and Indicators.....	2-142
Forward - defined.....	iv
Foul Weather Gear Locker description and location.....	1-39
Four crewmember stateroom description and location.....	1-36
Freezer	
Model F20-2M-ADS	
Controls and indicators.....	2-183
Operation.....	2-561
Model F30-2M-ADS	
Controls and Indicators.....	2-182
Operation.....	2-561
Fresh water make-up description and location.....	1-16
Fresh Water Makers description and location.....	1-54
Fresh Water Makers PMCS.....	2-274
Fresh Water Motor Controller controls and Indicators.....	2-102

INDEX - CONT

SUBJECT	Page
<b>F - Cont</b>	
Fresh Water Piping System Shutdown.....	2-589
Fresh Water Piping System Principles of Operation.....	1-108
Reverse Osmosis Watermakers Principles of Operation .....	1-108
FW Pumps No. 1 and No. 2 Principles of Operation.....	1-108
Pressure Switches Principles of Operation.....	1-108
Pressure Tank Principles of Operation.....	1-108
Hot Water Heater Principles of Operation .....	1-117
Booster Pump Principles of Operation.....	1-117
Booster Heater Principles of Operation .....	1-117
Tank Level Indicator Transmitters Principles of Operation.....	1-117
Fresh Water Pressure Tank description and location.....	1-54
Fresh Water Pump Motor Controllers description and location.....	1-54
Fresh Water pumps description and location.....	1-54
Fresh Water Pumps PMCS.....	2-263
Fresh Water Sounding Tube description and location.....	1-14
Fresh Water tanks description and location.....	1-54
Fry Kettle	
Controls and indicators .....	2-186
Operation.....	2-569
Fuel Filter/Coalescer description and location.....	1-54
Fuel Filter/Coalescer PMCS .....	2-262
Fuel Oil Filter, Transfer, and Supply Piping System Operation .....	2-471
Fueling Operation .....	2-471
Transfer Fuel Oil Between Fuel Oil Tanks.....	2-478
Defueling Operation.....	2-483
Fuel all station description and location .....	1-14
Fuel Oil Transfer Piping System Principles of Operation.....	1-154
Fuel Oil Transfer Pump Motor Controller controls and Indicators .....	2-104
Fuel Suction Manifold description and location .....	1-57
Fuel Supply Manifold description and location .....	1-57
Fuel Transfer Hand Pump PMCS .....	2-262
Fuel Transfer Pump Controller description and location.....	1-57
Fuel Transfer Pumps description and location .....	1-54
Fuel Transfer Pumps PMCS .....	2-262

**G**

Galley description and location.....	1-41
Gangway connection brackets description and location.....	1-12
Gasoline quick jettison storage rack description and location.....	1-16
Gaylord Hood	
Controls and indicators .....	2-170
Operation.....	2-554
PMCS .....	2-237
Gaylord hood exhaust description and location.....	1-10
General Alarm bell description and location .....	1-67
General alarm bell description and location .....	1-60
General Alarm Contact Maker description and location.....	1-23
General Alarm Contact Maker description and location.....	1-46

INDEX - CONT

SUBJECT	Page
<b>G - Cont</b>	
General Alarm Light description and location.....	1-56
General description.....	1-1
Grenade fuse H206A1 locker description and location.....	1-12
Grenade - MK 3A1 locker description and location.....	1-12
Gyro Compass	
Controls and indicators.....	2-24
Shutdown.....	2-589
Unusual Operation.....	2-642
Heavy Sea Starting.....	2-642
Emergency Restarting.....	2-648
PMCS.....	2-227
Operation.....	2-357
Gyrocompass MARK 27 MOD 1.....	2-357
Mark 37 Mod E Transmission Unit.....	2-363
Synchronize Compass Repeaters After Ship Service Power Failure.....	2-365
Autopilot Mode.....	2-365
Gyro Compass System Principles of Operation.....	1-90
Mk 37 Mod E Relay Transmitter Principles of Operation.....	1-90
Compass Repeaters Principles of Operation.....	1-90
Power Principles of Operation.....	1-90
Gyro compass transmission unit description and location.....	1-25
Gyro repeater description and location.....	1-10
Gyro Repeater PMCS.....	2-220, 2-222, 2-227
Gyrocompass description and location.....	1-25

**H**

HALON 1301 Fire Suppression System	
Manual Operation.....	2-651
Manual Release for Fire in Main Machinery Room.....	2-651
Manual Release for Fire in Paint Locker.....	2-651
Operation.....	2-443
Main Engine Room Operation.....	2-443
Paint Locker Operation.....	2-446
HALON Bottles description and location.....	1-18
HALON bottles description and location.....	1-46
HALON fire system alarm description and location.....	1-60
HALON warning light description and location.....	1-54
HALON Warning Light description and location.....	1-48
Handling Davit PMCS.....	2-235, 2-243, 2-235
Hawsepipe description and location.....	1-18
Head Set-Chest Set	
Controls and indicators.....	2-46
Operation.....	2-525
PMCS.....	2-215
Heavy Weather Preparations.....	2-709
Helm	
Controls and indicators.....	2-9
PMCS.....	2-229

INDEX - CONT

SUBJECT	Page
<b>H - Cont</b>	
Helm description and location.....	1-25
High pressure hydraulic system warning.....	Inside front cover
How to use this manual.....	iii
Hull description.....	1-6
Hydraulic cylinders description and location.....	1-50
Hydraulic Fluid Storage Tank PMCS.....	2-277
Hydraulic fluid storage tank description and location.....	1-64
Hydraulic oil filling point description and location.....	1-16
Hydraulic Oil Supply Piping System Operation.....	2-492
Hydraulic Oil Supply Piping System Principles of Operation.....	1-154
<b>I</b>	
Ice Maker controls and indicators.....	2-187
Identification Friend or Foe description and location.....	1-33
Inboard profile features.....	1-20
Intake for steering compartment description and location.....	1-16
intercom Controls and Indicators.....	2-48
Operation.....	2-530
PMCS.....	2-214
Intercom description and location.....	1-23
Intercom description and location.....	1-50
Intercom description and location.....	1-64
Intercom description and location.....	1-67
Intercom description and location.....	1-57
Intercom location.....	1-42
Intercom location.....	1-43
Internal features.....	1-20
	to
	1-71
IP-1469/SPS-16(V)17 location.....	1-25
IP-1469/SPS-64(V)16 location.....	1-25
<b>J</b>	
Jack staff description and location.....	1-18
Junction box description and location.....	1-36
Junction Box description and location.....	1-50
<b>K</b>	
Key box description and location.....	1-57
<b>L</b>	
L102 description and location.....	1-54
L105 description and location.....	1-33
Launch Liferrafts.....	2-706
Launch Workboat in Heavy Weather.....	2-704
Laundry Equipment Principles of Operation.....	1-101

INDEX- CONT

SUBJECT

	L - Cont	Page
Laundry room description and location.....		1-38
LCU Capabilities.....		1-5
LCU Characteristics.....		1-5
LCU decks defined.....		1-5
LCU Features.....		1-5
LCU Profile description.....		1-6
Lever Operated Control (Halon 1301 Fire Suppression System).....		2-146
Life Jacket PMCS.....		2-213
Life Lines and Stanchions PMCS.....		2-213
Life Ring PMCS.....		2-213
Life Support System Operation		
Air Conditioning.....		2-333
Fresh Water Piping System.....		2-342
Marine Sanitation Device.....		2-352
Ventilation.....		2-331
Water Purification System.....		2-342
Liferaft		
Controls and indicators.....		2-156
Operation.....		2-576
PMCS.....	2-223, 2-225,	2-226
Liferaft description and location.....		1-10
Location terms - defined.....		iv
Log Table description and location.....		1-26
Lube Oil Hand transfer pumps description and location.....		1-54
Lube Oil Purification and Transfer Piping System Operation		
Discharge Oil From Dirty Oil Tank.....		2-469
Discharge Sludge From Sludge Tank.....		2-470
Lube Oil Purifier/Clarifier Operation.....		2-454
Lube Oil Purifier/Clarifier Shutdown.....		2-466
Transfer Lube Oil From Engines to Dirty Oil Tank.....		2-467
Transfer Oil to Bowthruster Engine.....		2-470
Lube Oil Purifier		
Controls and indicators.....		2-106
Operation.....		2-454
PMCS.....		2-274
Lube Oil purifier description and location.....		1-54
Lube Oil supply point description and location.....		1-16
Lube oil tank vent description and location.....		1-46
Lubrication Oil Transfer and Purification Piping System Principles of Operation.....		1-168
Lubricating Oil Transfer Hand Pump PMCS.....		2-274
Lubrication Instructions.....		3-1

M

Machine shop description and location.....		1-60
Machine Shop description and location.....		1-54
Machinery Plant Monitor Panel controls and indicators.....		2-52
Machinery plant monitor system description and location.....		1-21

INDEX - CONT

SUBJECT	Page
<b>M - Cont</b>	
Magnet compass periscope description and location.....	1-23
Magnetic Compass	
Controls and indicators.....	2-28
PMCS .....	2-220
Magnetic Compass description and location .....	1-12
Magnetic Compass Principles of Operation.....	1-104
Main Damage Control Locker description and location:.....	1-48
Main deck description .....	1-5
Main Deck External Features description and location.....	1-14
Main Deck Locker description and location .....	1-39 to 1-48
Main Engine	
Main Engine Cold Weather Starting .....	2-669
Engine Block Heater Operation .....	2-669
Preheat Lubrication Oil Operation .....	2-669
Preheat Lubrication Oil Shutdown .....	2-682
Main Engine Control Panel controls and indicators.....	2-90
Main Engine PMCS.....	2-256, 2-271
Main Engine Shutdown .....	2-589
Main Engine Throttle Control.....	2-4
Main Propulsion System Operation .....	2-387
Port Main Engine Operation .....	2-408
Prelube Port Main Engine.....	2-421
Prelube STBD Main Engine.....	2-390
Starboard Main Engine Operation .....	2-387
Main Engine description and location.....	1-52
Main Engine description and location.....	1-52
Main Engine Fresh Water Cooling Piping System Principles of Operation .....	1-134
Main Switchboard	
Controls and indicators.....	2-60
PMCS .....	2-276
Main Switchboard description and location .....	1-52
Main switchboard description and location.....	1-60
Maintenance Instructions .....	3-1
Manual hand pump description and location.....	1-64
Manual hand pumps description and location.....	1-67
Manual Hand Pumps PMCS .....	2-279
Manual Hydraulic pump description and location .....	1-52
Manual pull station for HALON system description and location.....	1-16
Marine Coffee Maker, OT-20	
Controls and indicators.....	2-179
Operation.....	2-568
Marine Electric Range	
Controls and indicators.....	2-168
Operation.....	2-556
Marine Fire Detector Panel description and location .....	1-26
Power Transformer description and location.....	1-26
Marine Fire Detector Panel	
Controls and indicators.....	2-38
PMCS .....	2-232



INDEX - CONT

SUBJECT	Page
<b>M - Cont</b>	
Marine Freezer	
Operation.....	2-561
PMCS.....	2-235
Marine Refrigerator	
Operation.....	2-561
PMCS.....	2-236
Marine Sanitation Device	
Controls and .....	2-108
Operation.....	2-352
PMCS.....	2-272
Marine Sanitation Device description and location.....	1-52
Marine sanitation device vent description and location.....	1-16
Marine sanitation monitor panel description and location.....	1-57
Mark 37 Mod E Transmission Unit Controls and Indicators.....	2-26
Mast and Yardarm PMCS.....	2-218
Mast description.....	1-7
Mast description and location.....	1-10
Meat Slicer	
Controls and indicators.....	2-173
Operation.....	2-560
Mess Deck description and location.....	1-42
Microwave Oven	
Controls and indicators.....	2-174
Operation.....	2-562
PMCS.....	2-237
Milk Dispenser	
Controls and indicators.....	2-177
Operation.....	2-562
PMCS.....	2-238
Modification hazard warning.....	Inside front cover
Modulator transmitter/receiver location.....	1-25
Modulator transmitter/receiver location.....	1-25
Monitor Panel.....	2-275
Moving machinery warning.....	Inside front cover
Multiple sanitary space description and location.....	1-38
<b>N</b>	
Navigation Light panel description and location.....	1-26
Navigation Lighting System	
Navigation Light Panel	
Controls and indicators.....	2-36
PMCS.....	2-232
Navigation Lighting System Principles of Operation.....	1-104
NBC Decontamination Procedures.....	2-707
Nomenclature Cross Reference List.....	1-2
Officer's sanitary space description and location.....	1-38

INDEX - CONT

SUBJECT	Page
<b>O - Cont</b>	
Oil-Water Separator description and location.....	1-52
Oil-Water Separator Piping System	
Oil-Water Separator.....	2-484
Controls and indicators.....	2-98
PMC.....	2-273
System start-Up .....	2-484
System Shutdown.....	2-492
Oily Water Separator Piping System Principles of Operation.....	1-168
Omega receiver description and location.....	1-28
Open Scale Compass Repeater Controls and Indicators.....	2-31
Open scale steering gyro repeater description and location.....	1-23
Outboard motor description and location.....	1-12
Oxygen Breathing Apparatus (OBA) Controls and Indicators.....	2-150
<b>P</b>	
P106 location.....	1-41
P201 description and location.....	1-67
P202 location.....	1-41
P203 description and location.....	1-54
P204-4 location.....	1-41
P204 description and location.....	1-52
P211-3 description and location.....	1-67
P211-4 description and location.....	1-67
P211-7 location.....	1-41
P211-9 location.....	1-41
P211 description and location.....	1-64
Paint brush container description and location.....	1-48
Paint locker description and location.....	1-48
Paint Locker HALON 1301 Fire Suppression System PMCS.....	2-247
Paint locker internal features description and location.....	1-48
Parallel Generators.....	2-385
Phone station description and location.....	1-57
Pilothouse Air Handling Unit PMCS.....	2-228
Pilothouse Console	
Controls and indicators.....	2-4
PMCS.....	2-229
Pilothouse control console cabinet description and location.....	1-25
Pilothouse control console description and location.....	1-21
Pilothouse external features .....	1-10
Pilothouse internal features .....	1-21
Pilothouse top description.....	1-5
Piping Diagrams	
How to use.....	v
Symbol legend.....	v
Piping PMCS.....	2-218
Plotting Board description and location.....	1-26

INDEX - CONT

SUBJECT	Page
<b>P - Cont</b>	
Pneumatic Switch (HALON 1301 Fire Suppression System) Control and Indicators .....	2-148
Port Anchor Windlass Hydraulic Power Unit PMCS .....	2-279
Port - defined.....	iv
Port M.E. throttle/clutch description and location.....	1-23
Port Main Generator Operation.....	2-366
Port Reduction Gear Oil Cooling Pump PMCS .....	2-274
Port shaft tachometer description and location.....	1-23
Portable CO2 Fire Extinguisher PMCS .....	2-214
Portable Fire Pump	
Automatic Priming Startup .....	2-544
Controls and Indicators.....	2-152
Manual Priming Startup .....	2-546
Manual Start-up with Automatic Priming .....	2-549
Manual Start-up with Manual Priming .....	2-551
Operation .....	2-544
PMCS.....	2-250
Shutdown .....	2-548
Post-Mix Dispenser	
Controls and indicators.....	2-178
Operation .....	2-565
Power and Lighting Distribution Panels Controls and Indicators.....	2-192
Power Cable Connections.....	2-579
Power Cable Disconnect.....	2-583
Power converter description and location.....	1-25
Power Distribution System PMCS.....	2-217
Power Generation Operation .....	2-290
Power Generation System Principles of Operation.....	1-73
Ship's Service Diesel Generator Engine Principles of Operation.....	1-73
Ship's Service Generator Principles of Operation .....	1-73
Emergency Diesel Generator Engine Principles of Operation .....	1-77
Emergency Generator Principles of Operation.....	1-77
Main Switchboard Principles of Operation.....	1-73
Emergency Switchboard Principles of Operation.....	1-73
Shore Power Box Principles of Operation.....	1-77
Power Mode Switch - URC-80 description and location.....	1-23
Power Supply description and location.....	1-33
Power transfer unit description and location.....	1-25
Prelube Oil Pump PMCS .....	2-273
Prelube Pump description and location.....	1-52
Preparation for Use.....	2-284
Propeller and Propeller Shaft PMCS.....	2-255, 2-272
Propeller shaft description .....	1-6
Propeller Shaft, Propeller, and Shaft Brake Principles of Operation.....	1-168
Provisions Storeroom description and location.....	1-40
Purifier preheater description and location.....	1-54
Purifier Preheater PMCS .....	2-274
Pyrotechnic Signal Locker, Ammo Locker, Grenade MK3A1 Locker, and Grenade Fuse M206A1 Locker PMCS.....	2-223

INDEX - CONT

SUBJECT	Page
<b>P - Cont</b>	
Pyrotechnic Signal Locker Description and Location.....	1-12
<b>R</b>	
Radar Antenna description and location.....	1-10
Radar Antenna description and location.....	1-12
Radar Display location.....	1-25
Radar Display location.....	1-25
Radar Distribution panel location .....	1-25
Radar Interswitch location.....	1-25
Radar Isolation Transformer location .....	1-25
Radio Frequency Amplifier description and location.....	1-33
Radio HI1der description and location.....	1-33
Radio Transmitter description and location .....	1-33
Radiotelephone Alarm Generator description and location.....	1-26
Receiver Transmitter description and location .....	1-28
* Recreation Room Description and Location (Except LCU 2008, 9, 10, 11, 12) .....	1-43
Red lighting switch description and location.....	1-26
Reduction Gear Cooling Pump description and location.....	1-52
Reduction Gear description and location.....	1-52
Reduction Gear description and location.....	1-52
Reduction Gear Lubricating Oil Fresh Water Cooling Piping System Principles of Operation.....	1-134
Reduction Gear PMCS .....	2-255
References.....	A-1
Refrigerator	
Model R18-2M-S	
Controls and indicators.....	2-185
Operation.....	2-561
PMCS .....	2-236
Model R30-2M-S	
Controls and indicators.....	2-184
Operation.....	2-561
PMCS .....	2-235
Remote bowthruster control description and location.....	1-69
Remote Lever Operated Control (HALON 1301 Fire Suppression System):.....	2-147
Reporting Equipment Improvement Recommendations .....	1-2
Reporting errors and recommending improvements.....	i
Rescue/Workboat and Crane	
Controls and indicators.....	2-157
Rescue Workboat Crane	
Controls and Indicators.....	2-158
Operation.....	2-576
PMCS .....	2-225
Shutdown.....	2-579
Start-up .....	2-576
Rescue/Workboat Outboard Motor PMCS.....	2-224
Rescue/Workboat PMCS .....	2-225
Rescue/workboat crane description and location.....	1-10

## INDEX - CONT

SUBJECT	Page
<b>R - Cont</b>	
Rescue/workboat description and location.....	1-10
Reset Emergency Generator Operation.....	2-642
Reset Switch description and location.....	1-36
Retrieve Workboat in Heavy Weather .....	2-706
Reverse Osmosis Desalinators Controls and Indicators.....	2-100
Reverse Reduction Gearbox System Principles of Operation.....	1-98
Reverse Reduction Gear Principles of Operation.....	1-99
Lubricating Oil Cooling Pump Principles of Operation .....	1-99
Shaft Brake Principles of Operation .....	1-99
Bowthruster Power Supply Principles of Operation.....	1-99
Engine Instrument Control Panel Principles of Operation.....	1-99
Electrical System Principles of Operation.....	1-99
Fuel System Principles of Operation .....	1-99
Lubricating System Principles of Operation.....	1-99
Cooling System Principles of Operation .....	1-99
Power Takeoff Principles of Operation.....	1-100
Rigging Gangplank.....	2-584
Rigging LCU to be Towed.....	2-682
Rigging LCU to TOW.....	2-635
Roller fairlead description and location .....	1-14
Roller Fairlead PMCS .....	2-232, 2-233
Rotary Window wiper description and location.....	1-23
Rotary Window Wipers.....	2-538
Operation.....	2-538
Shutdown.....	2-541
RT-1241A location.....	1-25
RT-1342B location.....	1-25
RT-1600/U description and location.....	1-28
Rudder Angle Indicator Controls and Indicators.....	2-4
Rudder Angle Indicator description and location.....	1-23
Rudder angle indicator description and location.....	1-10
Rudder description.....	1-7
Rudder post access plate description and location.....	1-16
Rudder stock description and location.....	1-50
<b>S</b>	
SA-2308/SPS-64(V) location.....	1-25
Safe description and location.....	1-33
SB-4183/SPS-64(V) location.....	1-25
Sea Water Circulating Pump PMCS .....	2-269
Seachest blowdown vent description and location.....	1-69
Searchlight description and location.....	1-12
Searchlight lever/gear control description and location .....	1-23
Searchlight PMCS .....	2-219, 2-219
Searchlight Lever/Gear Control (STBD) PMCS .....	2-227, 2-227
Searchlight Power Supply PMCS.....	2-231
see also 500 Watt ZENON Searchlight	

INDEX - CONT

SUBJECT	Page
<b>S - Cont</b>	
Searchlight Power Supply description and location.....	1-26
Port description and location.....	1-26
Starboard description and location.....	1-26
Seawater Circulating Pump description and location.....	1-56
Seawater Cooling Piping System Principles of Operation.....	1-134
Secure tool storage room description and location.....	1-64
Sewage Piping System Principles of Operation.....	1-168
Shaft Tachometer Controls and Indicators.....	2-4
Shifting to Shore Power.....	2-580
Ship Service Diesel Generator	
Controls and indicators.....	2-92
PMCS.....	2-258, 2-264
Shutdown.....	2-604
STBD Generator Operation.....	2-290
Shore Connections.....	2-579
Shore Power Cable Wiring.....	2-717
Shore Power Cable PMCS.....	2-234
Shore Power Terminal Box PMCS.....	2-233
Ship, Service Generator description and location.....	1-56
Ship Service Generator description and location.....	1-54
Ship's bell description and location.....	1-16
Ship's Service Diesel Generator (SSDG) Fresh Water and Cooling System	
Principles of Operation.....	1-134
Shore power cable stowage description and location.....	1-16
Shore power connection box description and location.....	1-12
Sickbay Description and Location.....	1-43
Side light box description and location.....	1-10
Signal Flag storage cabinet description and location.....	1-28
Single sanitary space description and location.....	1-38
Sludge Tank Indicator description and location.....	1-56
Socket for davit description and location.....	1-16
Socket for portable davit description and location.....	1-14
Sound Measuring Set description and location.....	1-30
Sound Powered Telephone	
Model MWT-R Controls and Indicators.....	2-45
Model SER Controls and Indicators.....	2-42
Model SFLR Controls and Indicators.....	2-44
Model SELR Controls and Indicators.....	2-43
Operation.....	2-525
PMCS.....	2-215
Sound powered telephone description and location.....	1-18
Sound powered telephone description and location.....	1-14
Sound powered telephone description and location.....	1-28
Sound Powered Telephone description and location.....	1-46
Sound Powered Telephone description and location.....	1-67
Sound powered telephone description and location.....	1-57
Sound Powered Telephone description and location.....	1-50
Sound Powered Telephone description and location.....	1-48
Sound Powered telephone description and location.....	1-60

## INDEX - CONT

SUBJECT	Page
<b>S - Cont</b>	
Sound Powered Telephone Jack description and location.....	1-67
Sound Powered Telephone Jack description and location.....	1-50
Sound powered telephone jackbox description and location.....	1-57
Sound Powered Telephone System Principles of Operation.....	1-104
Sounding Tables.....	F-1
Space Heaters PMCS.....	2-218
Speed log display unit description and location.....	1-28
Standard Bearing Repeater Controls and Indicators.....	2-30
Starboard - defined.....	iv
STBD M.E. throttle/clutch description and location.....	1-23
STBD Reduction Gear Oil Cooling Pump PMCS.....	2-273
STBD shaft tachometer description and location.....	1-21
Steering	
Steering Control Panel Controls and Indicators.....	2-8
Steering Gear and Linkage PMCS.....	2-251
Steering Gear Local Control Unit PMCS.....	2-252
Steering Gear Motor Controller Controls and Indicators.....	2-111
Steering Gear Room Local Control Unit Controls and Indicators.....	2-112
Steering System Failure.....	2-648
Steering System Operation.....	2-424
Autopilot Operation.....	2-431
Steering Gear System Operation.....	2-424
Steering System Preparation Procedures.....	2-424
Steering System Shutdown.....	2-433
Steering Compartment Escape Hatch description and location.....	1-46
Steering compartment hatch description and location.....	1-16
Steering compass repeaters description and location.....	1-50
Steering control panel description and location.....	1-21
Steering Gear Compartment description and location.....	1-50
Steering gear local control units description and location.....	1-50
Steering Gear System Principles of Operation.....	1-95
Steering Gear Hydraulic Piping System Principles of Operation.....	1-97
Main Propulsion System Principles of Operation.....	1-98
Engine Instrument and Control Panel Principles of Operation.....	1-98
Fuel System Principles of Operation.....	1-98
Air Starting System Principles of Operation.....	1-98
Lubricating Oil System Principles of Operation.....	1-98
Cooling System Principles of Operation.....	1-98
Steering hydraulic dual pump set description and location.....	1-52
Steering power pack motor controllers description and location.....	1-50
Step down transformer description and location.....	1-46
Stern anchor description.....	1-6
Stern Anchor hydraulic pump motor controller description and location.....	1-50
Stern Anchor Winch	
Controls.....	2-128
Hydraulic Fluid Tank PMCS.....	2-239
Hydraulic Pump PMCS.....	2-253
Operation.....	2-510
Hauling In Anchor.....	2-519

INDEX - CONT

SUBJECT	Page
<b>S - Cont</b>	
Lowering Anchor by Paying Out Wire Rope.....	2-514
Lowering Anchor by Releasing Brake Handwheel.....	2-517
Shutdown.....	2-520
Start-Up Procedure .....	2-510
Warping Head Operation.....	2-520
PMCS .....	2-232
Stern anchor winch description and location.....	1-14
Stern anchor winch hydraulic pump description and location.....	1-52
Stern anchor winch motor controller description and location.....	1-14
Stern Anchor Winch System Principles of Operation .....	1-101
Winch Assembly Principles of Operation.....	1-101
Hydraulic Power Pack Principles of Operation.....	1-101
Hydraulic Motor/Failsafe Brake Assembly Principles of Operation.....	1-101
Sternlight mast description and location.....	1-12
Storage cabinet description and location.....	1-28
Storage cabinet description and location.....	1-60
Storage cabinet description and location.....	1-36
Store Room description and location .....	1-56
Storeroom description and location.....	1-64
Stowage and Sign Guide.....	E-1
Suez Canal Light description and location.....	1-18
Supply fan description and location.....	1-46
Supply fan description and location.....	1-50
Surface Pull Box (HALON 1301 Fire Suppression System) Controls and Indicators .....	2-145
Survival suit storage description and location .....	1-30
Survival suit stowage description and location.....	1-60
Survival suit stowage description and location.....	1-36
SW-8P access plate description -and location.....	1-14
SW-8S access plate description and location.....	1-16
Switch description and location.....	1-36
Switch-Speech Secure Eqmt description and location.....	1-36
Switch unit description and location.....	1-25
<b>T</b>	
T-1527/URC location .....	1-33
Tactical Radio description and location.....	1-30
Tank level indicator description and location.....	1-64
Tank Level Indicators	
Controls and indicators.....	2-94
Operation.....	2-478
PMCS .....	2-263
Tank Level Indicators description and location.....	1-57
Tank Level Indicators description and location.....	1-56
Tank locations description and location.....	1-71
Telegraph Terminal description and location.....	1-33
Telephone headset storage box description and location.....	1-26
Telephone headset storage box description and location.....	1-50



INDEX – CONT.

SUBJECT	Page
<b>T – Cont.</b>	
Telephone Headset Storage Box Description and Location .....	1-60, 1-67
Telephone Storage Box Description and Location .....	1-12
Teletype Description and Location .....	1-33
Three Crewmember Stateroom Description and Location .....	1-36
Throttle Air Pressure Gauge Controls and Indicators .....	2-4
Tie Bar Description and Location .....	1-50
Tiller Description and Location .....	1-50
Tool Board Description and Location .....	1-64
Tools, Spare Parts and Equipment PMCS .....	2-277
Towing Hawser Reel Description and Location .....	1-14
Towing Hawser Reels PMCS .....	2-233
Transfer of Fuel Using Hand Pumps .....	2-710
Transferring Control Air to Bridge .....	2-521
Transformer Description and Location .....	1-33
Trash Can Rack Description and Location .....	1-16
Trash Compactor	
Controls and Indicators .....	2-180
Operation .....	2-565
Tunnel Description and Location .....	1-64
Tunnel Vent Fan Controller Description and Location .....	1-54
Two Crewmember Stateroom Description and Location .....	1-36
Type I Motor Switch Controls .....	2-189
Type II Motor Controller Controls and Indicators .....	2-190
<b>V</b>	
Vent Description and Location .....	1-18
Ventilation Control Center Description and Location .....	1-54
Ventilation Motor Control Center PMCS .....	2-277
Ventilation Supply Shaft Description and Location .....	1-67
Vessel Master's Stateroom Description and Location .....	1-38
Vise Description and Location .....	1-64
<b>W</b>	
Warnings, Cautions, Notes – Definition .....	iii
Warranty Information .....	1-2
Water Fountain Description and Location .....	1-36, 1-60
Water Washdown System (WWS) Principles of Operation .....	2-741
Welding Machine Description and Location .....	1-60
Welding Machine Motor Controller Description and Location .....	1-60
Wet/Dry Vacuum PMCS .....	2-276
Wildcat (Bow Ramp) Description and Location .....	1-18
Work Davit Description and Location .....	1-16
Workbench Description and Location .....	1-48
Workbenches Description and Location .....	1-60
Workboat/Liferafts Principles of Operation .....	1-168
Writing Shelf Description and Location .....	1-60



By Order of the Secretary of the Army:

**CARL E. VUONO**  
*General United States Army*  
*Chief of Staff*

Official:

**WILLIAM J. MEEHAN, II**  
*Brigadier General, United States Army*  
*The Adjutant General*

DISTRIBUTION:

To be distributed in accordance with DA Form 12-25A, Operator's Maintenance requirements for Landing Craft, Utility, LUC-1466, Type III.

***These are the instructions for sending an electronic 2028***

The following format must be used if submitting an electronic 2028. The subject line must be exactly the same and all fields must be included; however only the following fields are mandatory: 1, 3, 4, 5, 6, 7, 8, 9, 10, 13, 15, 16, 17, and 27.

From: "Whomever" <whomever@avma27.army.mil>  
To: mpmt%avma28@st-louis-emh7.army.mil

Subject: DA Form 2028

1. **From:** Joe Smith
2. **Unit:** home
3. **Address:** 4300 Park
4. **City:** Hometown
5. **St:** MO
6. **Zip:** 77777
7. **Date Sent:** 19-OCT-93
8. **Pub no:** 55-2840-229-23
9. **Pub Title:** TM
10. **Publication Date:** 04-JUL-85
11. **Change Number:** 7
12. **Submitter Rank:** MSG
13. **Submitter FName:** Joe
14. **Submitter MName:** T
15. **Submitter LName:** Smith
16. **Submitter Phone:** 123-123-1234
17. **Problem:** 1
18. **Page:** 2
19. **Paragraph:** 3
20. **Line:** 4
21. **NSN:** 5
22. **Reference:** 6
23. **Figure:** 7
24. **Table:** 8
25. **Item:** 9
26. **Total:** 123
27. **Text:**

This is the text for the problem below line 27.

RECOMMENDED CHANGES TO EQUIPMENT TECHNICAL PUBLICATIONS



THEN...JOT DOWN THE  
DOPE ABOUT IT ON THIS FORM.  
CAREFULLY TEAR IT OUT, FOLD IT  
AND DROP IT IN THE MAIL.

SOMETHING WRONG WITH PUBLICATION

FROM: (PRINT YOUR UNIT'S COMPLETE ADDRESS)

DATE SENT

PUBLICATION NUMBER

PUBLICATION DATE

PUBLICATION TITLE

BE EXACT PIN-POINT WHERE IT IS

PAGE  
NO.

PARA-  
GRAPH

FIGURE  
NO.

TABLE  
NO.

IN THIS SPACE, TELL WHAT IS WRONG  
AND WHAT SHOULD BE DONE ABOUT IT.

TEAR ALONG PERFORATED LINE

PRINTED NAME, GRADE OR TITLE AND TELEPHONE NUMBER

SIGN HERE

# The Metric System and Equivalents

## Linear Measure

1 centimeter = 10 millimeters = .39 inch  
 1 decimeter = 10 centimeters = 3.94 inches  
 1 meter = 10 decimeters = 39.37 inches  
 1 dekameter = 10 meters = 32.8 feet  
 1 hectometer = 10 dekameters = 328.08 feet  
 1 kilometer = 10 hectometers = 3,280.8 feet

## Weights

1 centigram = 10 milligrams = .15 grain  
 1 decigram = 10 centigrams = 1.54 grains  
 1 gram = 10 decigrams = .035 ounce  
 1 dekagram = 10 grams = .35 ounce  
 1 hectogram = 10 dekagrams = 3.52 ounces  
 1 kilogram = 10 hectograms = 2.2 pounds  
 1 quintal = 100 kilograms = 220.46 pounds  
 1 metric ton = 10 quintals = 1.1 short tons

## Liquid Measure

1 centiliter = 10 milliliters = .34 fl. ounce  
 1 deciliter = 10 centiliters = 3.38 fl. ounces  
 1 liter = 10 deciliters = 33.81 fl. ounces  
 1 dekaliter = 10 liters = 2.64 gallons  
 1 hectoliter = 10 dekaliters = 26.42 gallons  
 1 kiloliter = 10 hectoliters = 264.18 gallons

## Square Measure

1 sq. centimeter = 100 sq. millimeters = .155 sq. inch  
 1 sq. decimeter = 100 sq. centimeters = 15.5 sq. inches  
 1 sq. meter (centare) = 100 sq. decimeters = 10.76 sq. feet  
 1 sq. dekameter (are) = 100 sq. meters = 1,076.4 sq. feet  
 1 sq. hectometer (hectare) = 100 sq. dekameters = 2.47 acres  
 1 sq. kilometer = 100 sq. hectometers = .386 sq. mile

## Cubic Measure

1 cu. centimeter = 1000 cu. millimeters = .06 cu. inch  
 1 cu. decimeter = 1000 cu. centimeters = 61.02 cu. inches  
 1 cu. meter = 1000 cu. decimeters = 35.31 cu. feet

## Approximate Conversion Factors

To change	To	Multiply by	To change	To	Multiply by
inches	centimeters	2.540	ounce-inches	newton-meters	.007062
feet	meters	.305	centimeters	inches	.394
yards	meters	.914	meters	feet	3.280
miles	kilometers	1.609	meters	yards	1.094
square inches	square centimeters	6.451	kilometers	miles	.621
square feet	square meters	.093	square centimeters	square inches	.155
square yards	square meters	.836	square meters	square feet	10.764
square miles	square kilometers	2.590	square meters	square yards	1.196
acres	square hectometers	.405	square kilometers	square miles	.386
cubic feet	cubic meters	.028	square hectometers	acres	2.471
cubic yards	cubic meters	.765	square meters	cubic feet	35.315
fluid ounces	milliliters	29.573	cubic meters	cubic yards	1.308
pints	liters	.473	cubic meters	fluid ounces	.034
quarts	liters	.946	milliliters	pints	2.113
gallons	liters	3.785	liters	quarts	1.057
ounces	grams	28.349	liters	gallons	.264
pounds	kilograms	.454	grams	ounces	.035
short tons	metric tons	.907	kilograms	pounds	2.205
pound-feet	newton-meters	1.356	metric tons	short tons	1.102
pound-inches	newton-meters	.11296			

## Temperature (Exact)

°F	Fahrenheit temperature	5/9 (after subtracting 32)	Celsius temperature	°C
----	------------------------	----------------------------	---------------------	----

**PIN: 065851-010**